

Ride Mower

## YTH 20 B 42 T

960430020-03



Operator's Manual

# TRACTOR -- MODEL NUMBER YTH20B42T (96043002003), PRODUCT NO. 960 43 00-20 SCHEMATIC

02961-194276\_Regulated-Tex

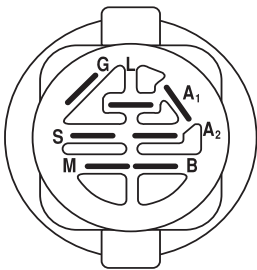
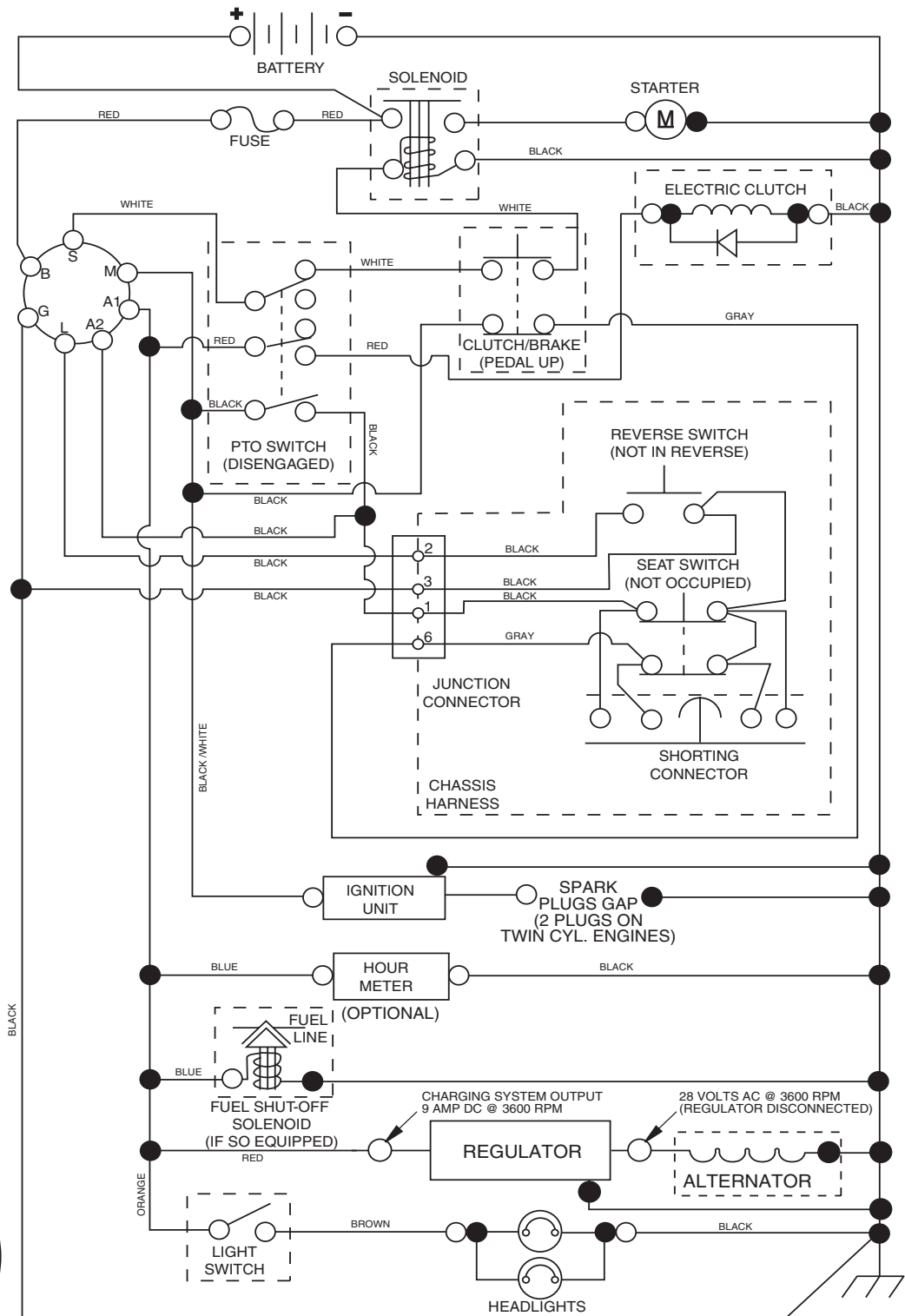

**IGNITION SWITCH**

POSITION	CIRCUIT	"MAKE"
OFF	M+G+A1	
RUN/OVERRIDE	B+A1	
RUN	B+A1	L+A2
START	B + S + A1	

02961

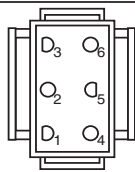

CHASSIS HARNESS CONNECTOR (MATING SIDE)

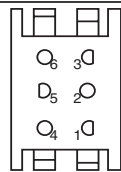

DASH HARNESS CONNECTOR (MATING SIDE)

**WIRING INSULATED CLIPS**

NOTE: IF WIRING INSULATED CLIPS WERE REMOVED FOR SERVICING OF UNIT, THEY SHOULD BE REPLACED TO PROPERLY SECURE YOUR WIRING.



NON-REMOVABLE CONNECTIONS



REMOVABLE CONNECTIONS

# TRACTOR -- MODEL NUMBER YTH20B42T (96043002003), PRODUCT NO. 960 43 00-20 ELECTRICAL

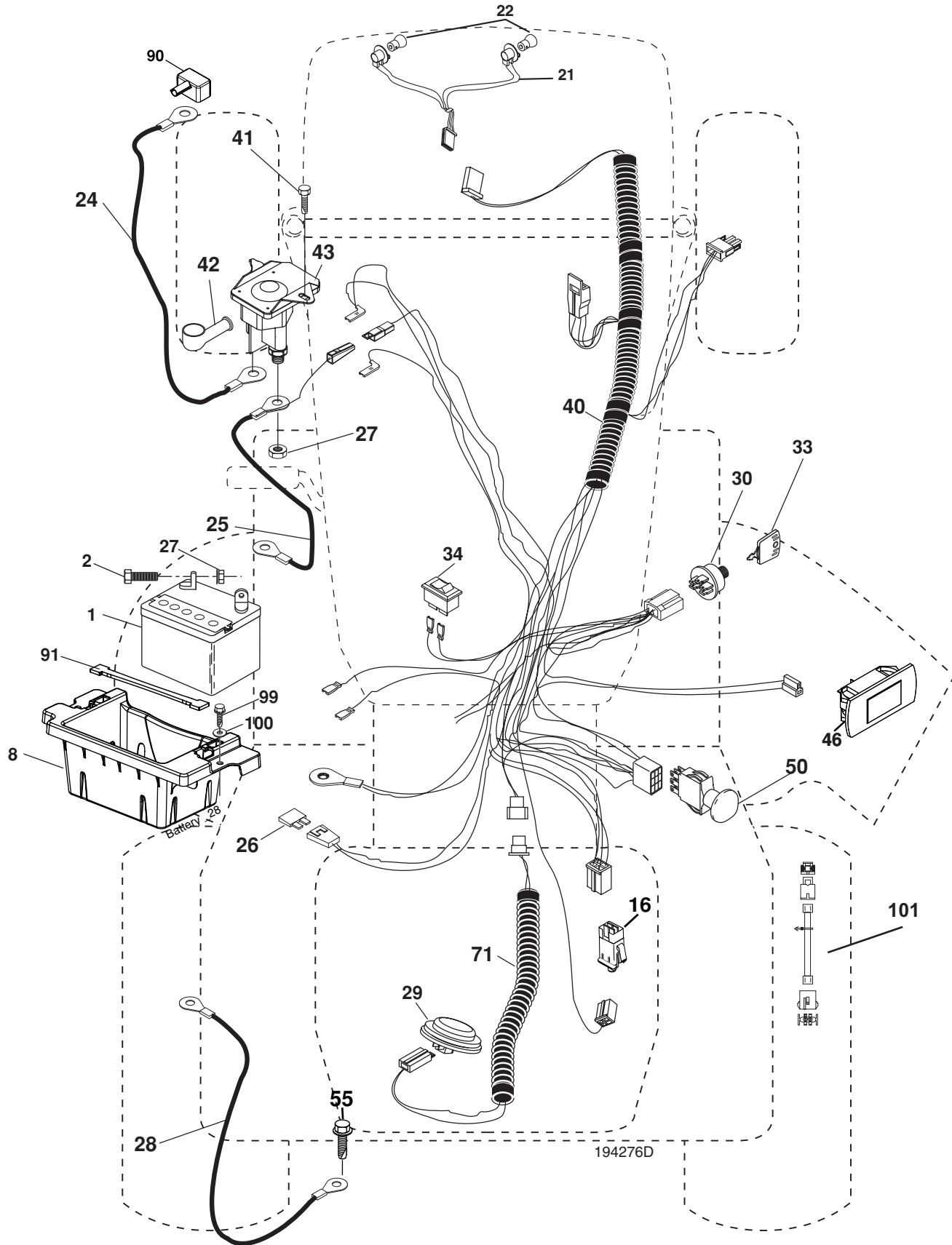

**TRACTOR -- MODEL NUMBER YTH20B42T (96043002003), PRODUCT NO. 960 43 00-20  
ELECTRICAL**

<b>KEY NO.</b>	<b>PART NO.</b>	<b>DESCRIPTION</b>
1	532 16 34-65	Battery
2	874 76 04-12	Bolt Hex Head 1/4-20 x 3/4
8	532 18 64-91	Box Battery
16	532 17 61-38	Switch Interlock Push-In
21	532 18 37-59	Harness Socket Light W/4152J
22	532 00 41-52	Bulb Light
24	532 40 02-53	Cable Brty
25	532 19 88-93	Cable Starter
26	532 17 51-58	Fuse
27	873 51 04-00	Nut Keps Hex 1/4-20 unc
28	532 14 54-91	Cable, Ground
29	532 40 15-45	Switch, Seat
30	532 19 33-50	Switch, Ign
33	532 14 04-01	Key, Ignition
34	532 11 07-12	Switch Light / Reset
40	532 19 42-76	Harness Ign.
41	817 72 04-08	Screw Thd Cut 1/4-20 x 1/2
42	532 13 15-63	Cover, Terminal
43	532 19 25-07	Solenoid
46	532 19 81-38	Gauge Servicere minder Hrmtr
50	532 17 46-51	Switch PTO
55	817 49 05-12	Screw Thdrol 5/16-18 x 3/4 TYTT
71	532 40 11-04	Harness Ign. Dash
90	532 40 07-24	Cover Terminal
91	532 19 02-70	Strap Battery Mount Front
99	817 67 04-12	Screw Hexwsh Thdrol 1/4-20 x 3/4
100	819 09 14-16	Washer 9/32 x 7/8 x 16 Ga.
101	532 40 44-54	Harness Pigtail ROS

**NOTE:** All component dimensions given in U.S. inches  
1 inch = 25.4 mm

**TRACTOR -- MODEL NUMBER YTH20B42T (96043002003), PRODUCT NO. 960 43 00-20  
CHASSIS**

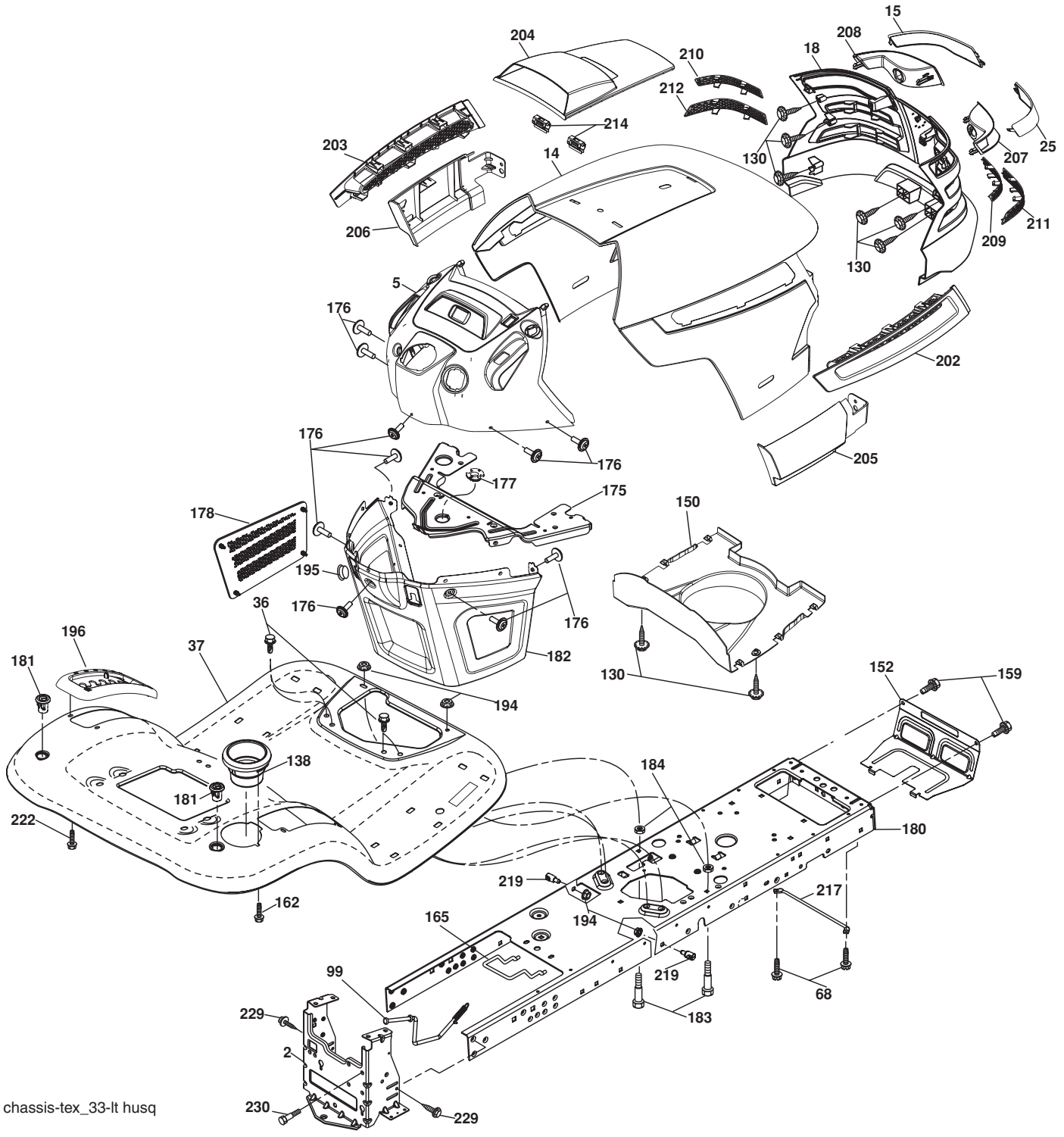

chassis-tex\_33-lt husq

**TRACTOR -- MODEL NUMBER YTH20B42T (96043002003), PRODUCT NO. 960 43 00-20  
CHASSIS**

<b>KEY NO.</b>	<b>PART NO.</b>	<b>DESCRIPTION</b>
2	532 19 42-63	Drawbar
5	532 40 32-05	Dash
14	532 40 18-24	Hood
15	532 19 89-07	Lens LH
18	532 40-48-21	Grille/Lens Asm.
25	532 19 89-06	Lens RH
36	817 06 05-12	Screw 5/16-18 x 3/4
37	532 40 49-40	Fender
68	817 49 05-08	Screw Thdrol 5/16-18 x 1/2
99	532 40 15-30	Rod Asm Bypass
130	532 19 16-11	Screw 10 x 3/4 Single Lead-Hex
138	532 40 29-54	Cupholder
150	532 19 85-14	Air Duct
152	532 19 43-29	Shield Browning
159	817 00 06-12	Screw 3/8-16 x 3/4
162	532 14 24-32	Screw
165	532 19 43-30	Support Tank Rear
175	532 19 63-04	Crossmember
176	532 40 07-76	Screw 10-24 x 5/8
177	532 19 52-27	Bushing Steering
178	532 19 97-82	Cargo Net Asm.
180	532 19 42-60	Chassis
181	532 40 30-25	Bushing Mtg. Fender Crgo
182	532 19 47-87	Dash Lower
183	874 78 05-20	Bolt Fin Hex 5/16-18 unc x 1-1/4
184	532 19 57-80	Spacer Fender
194	873 90 05-00	Nut Lock Hex Flange 5/16-18
195	532 40 41-37	Plug Hole Dash Lower
196	532 40 28-43	Console Asm. Deck Lift
202	532 40 30-48	Vent Side Hood RH
203	532 40 30-76	Vent Side Hood LH
204	532 19 89-04	Vent Top Hood
205	532 40 17-09	Skirt Hood Side RH
206	532 40 17-11	Skirt Hood Side LH
207	532 19 71-98	Bezel RH
208	532 19 71-99	Bezel LH
209	532 19 91-30	Insert Hex Top RH
210	532 19 91-31	Insert Hex Top Lh
211	532 19 91-32	Insert Hex Bottom RH
212	532 19 91-33	Insert Hex Bottom LH
214	532 19 91-45	Clip Retainer Tinner
217	532 15 65-24	Rod Pivot
219	532 19 51-61	Stud Fastner
222	532 13 77-29	Screw Thdrol 1/4-20 x 5/8
229	817 00 06-16	Screw Hexwsh Thdr 3/8-16 x 3/4
230	532 17 01-65	Bolt Shoulder 5/16-18

**NOTE:** All component dimensions given in U.S. inches  
1 inch = 25.4 mm

**TRACTOR -- MODEL NUMBER YTH20B42T (96043002003), PRODUCT NO. 960 43 00-20  
DRIVE**

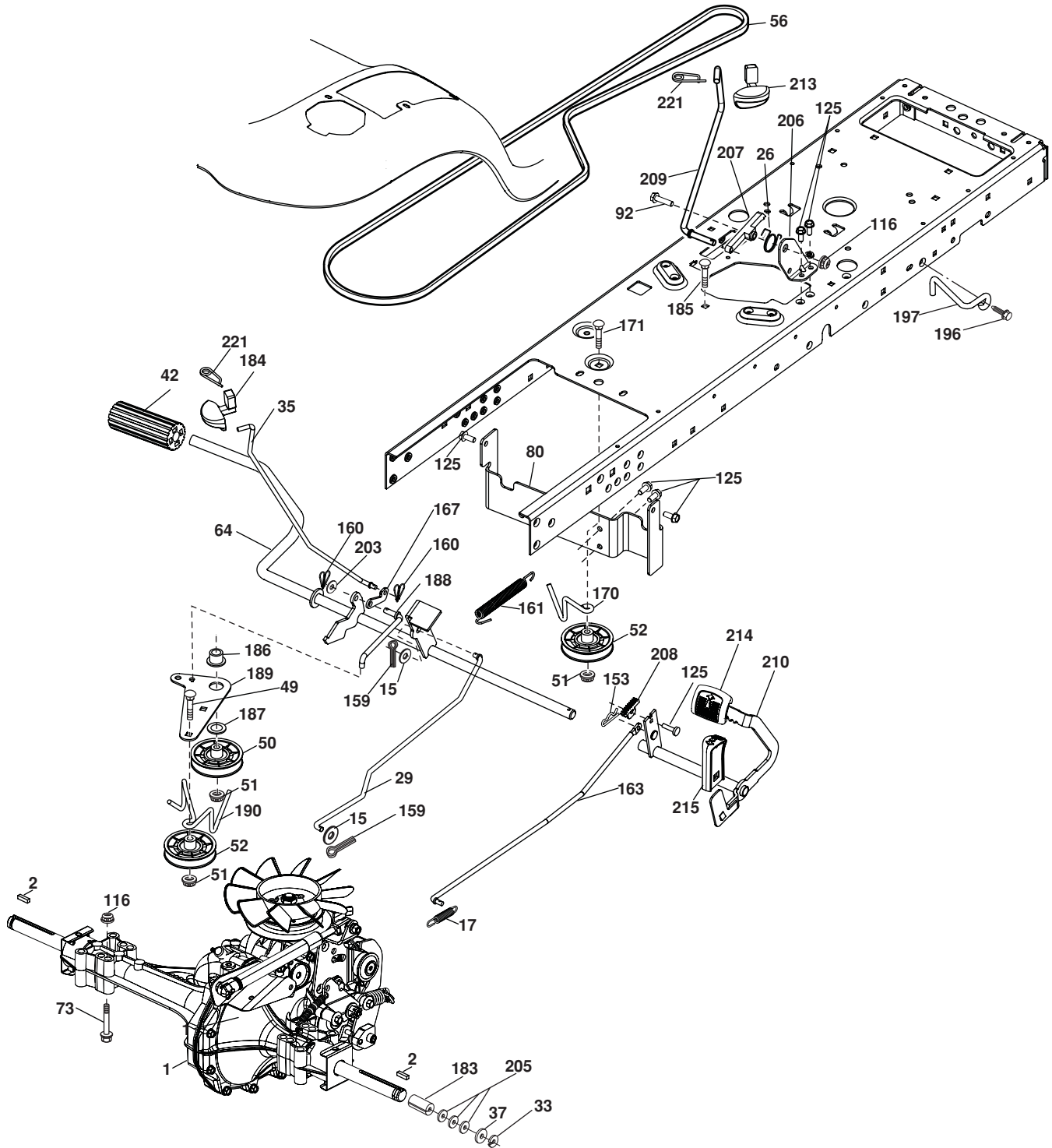

drive-tex\_17

**TRACTOR -- MODEL NUMBER YTH20B42T (96043002003), PRODUCT NO. 960 43 00-20  
DRIVE**

KEY NO.	PART NO.	DESCRIPTION
1	-----	Transaxle, Hydro 356-0510 (Order Parts from Transaxle Manufacturer)
2	532 12 35-83	Key Square
15	819 13 13-16	Washer 13/32 x 13/16 x 16 Ga.
17	532 19 72-96	Spring, Brake
26	532 19 96-79	Spring Return Cruise
29	532 19 76-59	Rod, Brake
33	812 00 00-01	Ring E
35	532 19 95-91	Rod, Brake, Park
37	532 12 17-49	Washer 25/32 x 1-1/4 x 16 Ga.
42	532 12 48-72	Cover, Foot Pedal
49	872 11 06-14	Bolt
50	532 19 43-27	Pulley Idler Flat
51	873 90 06-00	Lock Nut 3/8-16
52	532 19 43-26	Idler V-Groove 910" Offset
56	532 14 02-18	V-Belt, Drive
64	53219 78-65	Shaft Asm. Pedal Brake Control
73	874 49 05-44	Bolt Hex Flghd 5/16-18 x 3.0 Gr. 5
80	532 40 05-07	Bracket Strap Torque
92	874 76 05-20	Bolt Fin Hex 5/16-18 unc x 1.25
116	873 90 05-00	Nut Lock Hex Flange 5/16-18
125	817 00 05-12	Screw 5/16-18 x 3/4
153	532 12 47-88	Retainer Spring
159	876 02 04-12	Pin Cotter 1/8 x 3/4
160	532 16 94-84	Retainer Clip
161	532 19 54-03	Spring, Return, Clutch

KEY NO.	PART NO.	DESCRIPTION
163	532 19 90-00	Rod Pedal Control
167	532 19 62-11	Latch Brake Parking
170	532 19 43-22	Keeper Belt Centerspan
171	872 11 06-16	Bolt
183	532 13 70-57	Spacer Axle
184	532 40 31-18	Handle Parking Brake
185	872 11 06-20	Bolt
186	532 19 43-21	Spacer Retainer
187	819 13 32-10	Washer
188	532 19 43-23	Link Clutch Ground Drive
189	532 19 43-17	Bellcrank Ground Drive
190	532 19 43-18	Keeper Bellcrank Ground Drive
196	817 00 06-16	Screw 3/8-16 x 1
197	532 19 58-04	Link Clutch Anti-Rotation
203	819 11 11-16	Washer 11/32 x 11/16 x 16 Ga.
205	532 12 17-48	Washer 25/32 x 1-5/8 16 Ga.
206	532 19 78-67	Bracket Mount Latch Cruise
207	532 19 78-68	Latch Control Cruise
208	532 19 78-69	Gear Sector Control Cruise
209	532 19 95-92	Rod Control Cruise
210	532 40 09-80	Rockr Asm. Pedal Control
213	532 40 31-19	Knob control Cruise
214	532 40 17-22	Pad Pedal Forward
215	532 40 17-23	Pad Pedal Reverse
221	532 40 31-87	Retainer Spring Clip

**NOTE:** All component dimensions given in U.S. inches  
1 inch = 25.4 mm



**TRACTOR -- MODEL NUMBER YTH20B42T (96043002003), PRODUCT NO. 960 43 00-20**  
**STEERING ASSEMBLY**

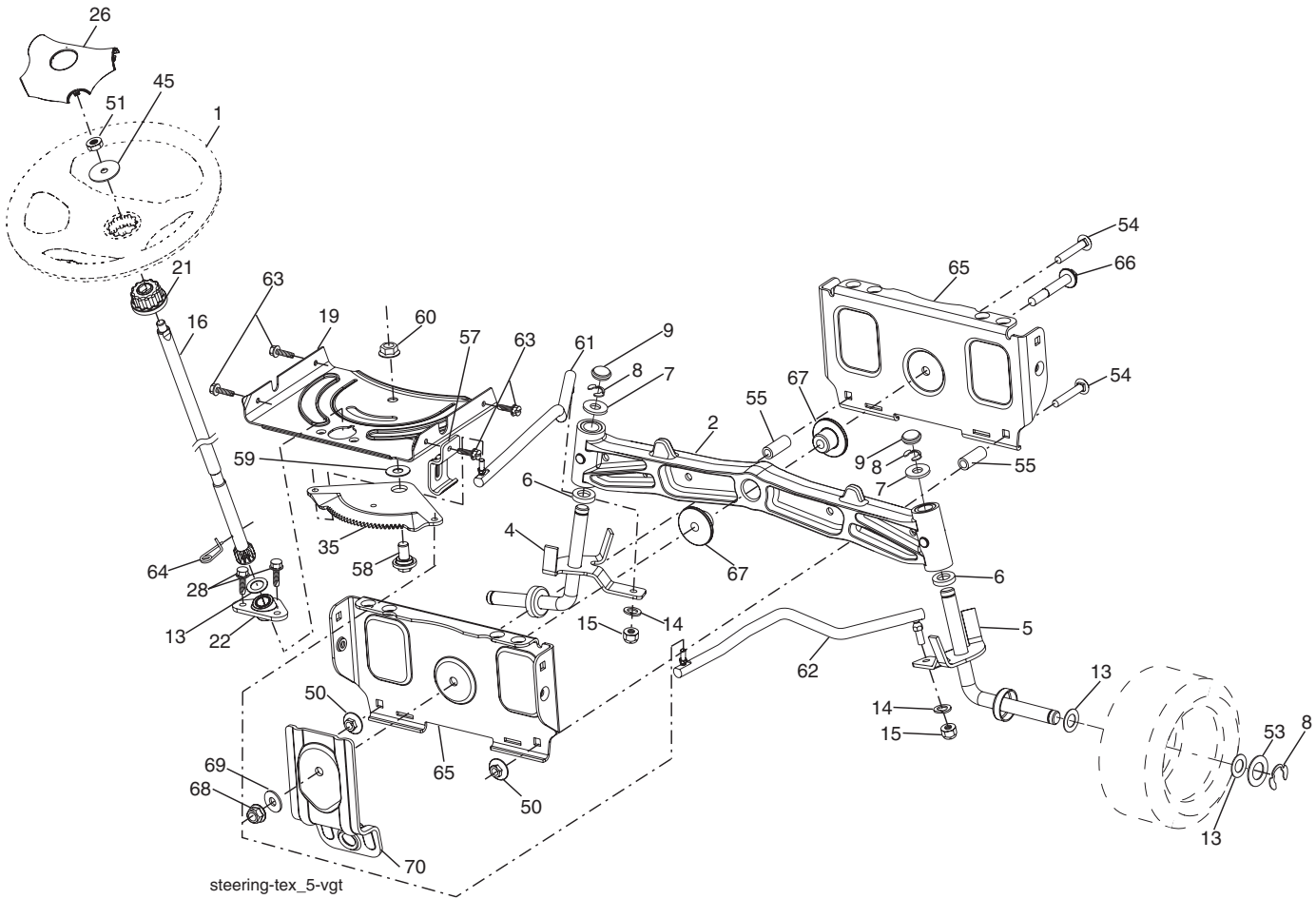

KEY NO.	PART NO.	DESCRIPTION
1	532 19 39-43	Wheel, Steering
2	532 19 59-68	Axle Asm., Front
4	532 40 30-87	Spindle Asm., LH
5	532 40 30-88	Spindle Asm., RH
6	532 12 49-31	Bearing, Race Thrust Harden
7	532 12 17-48	Washer 25/32 x 1-5/8 x 16 Ga.
8	812 00 00-29	Ring, Klip #T5304-75
9	532 12 12-32	Cap, Spindle
13	532 12 17-49	Washer 25/32 x 1-1/4 x 16 Ga.
14	810 04 06-00	Washer, Lock Hvy Hlcl Spr 3/8
15	873 54 06-00	Nut, Crown Lock 3/8-24 unf
16	532 19 47-46	Shaft Steering
19	532 19 47-29	Plate Steering
21	532 18 67-37	Adapter, Wheel Steering
22	532 19 48-45	Bushing, Strg. Blk
26	532 19 36-52	Insert, Wheel Steering
28	817 00 06-12	Screw 3/8-16 x 3/4
35	532 19 47-32	Gear, Sector Plate
45	819 18 38-12	Washer 9/16 ID x 2-3/8 OD 12 Ga.
50	873 90 06-00	Nut Lock 3/8-16 unc
51	873 94 08-00	Nut Hex Jam Toplock 1/2-20 unf

KEY NO.	PART NO.	DESCRIPTION
53	532 18 89-67	Washer Hardened .793 x 1.637 x .060
54	874 76 06-36	Bolt Hex 3/8-16 unc x 2-1/4
55	532 19 76-36	Spacer Brace Axle
57	532 19 72-46	Bracket Upstop
58	532 19 47-47	Bolt Shoulder Sector Pivot CFM
59	532 19 47-48	Washer Thrust Sector Steering
60	873 97 10-00	Nut Flange Lock 5/8-11
61	532 19 47-40	Draglink LH
62	532 19 47-41	Draglink, RH
63	817 00 05-12	Screw 5/16-18 x 3/4
64	532 19 98-49	Retainer Clip Spring Steering
65	532 19 47-34	Brace Axle Front
66	871 02 07-48	Bolt Hex Fghd 7/16-14 x 3 Serr
67	532 19 47-37	Bushing PM Front Axle
68	873 90 07-00	Nut Lock Flange 7/16-14 Gr. 5
69	532 19 91-62	Washer 1.5 x .505 x .118
70	532 19 61-97	Bracket Deck Susp. Front

**NOTE:** All component dimensions given in U.S. inches  
 1 inch = 25.4 mm

**TRACTOR -- MODEL NUMBER YTH20B42T (96043002003), PRODUCT NO. 960 43 00-20  
ENGINE**

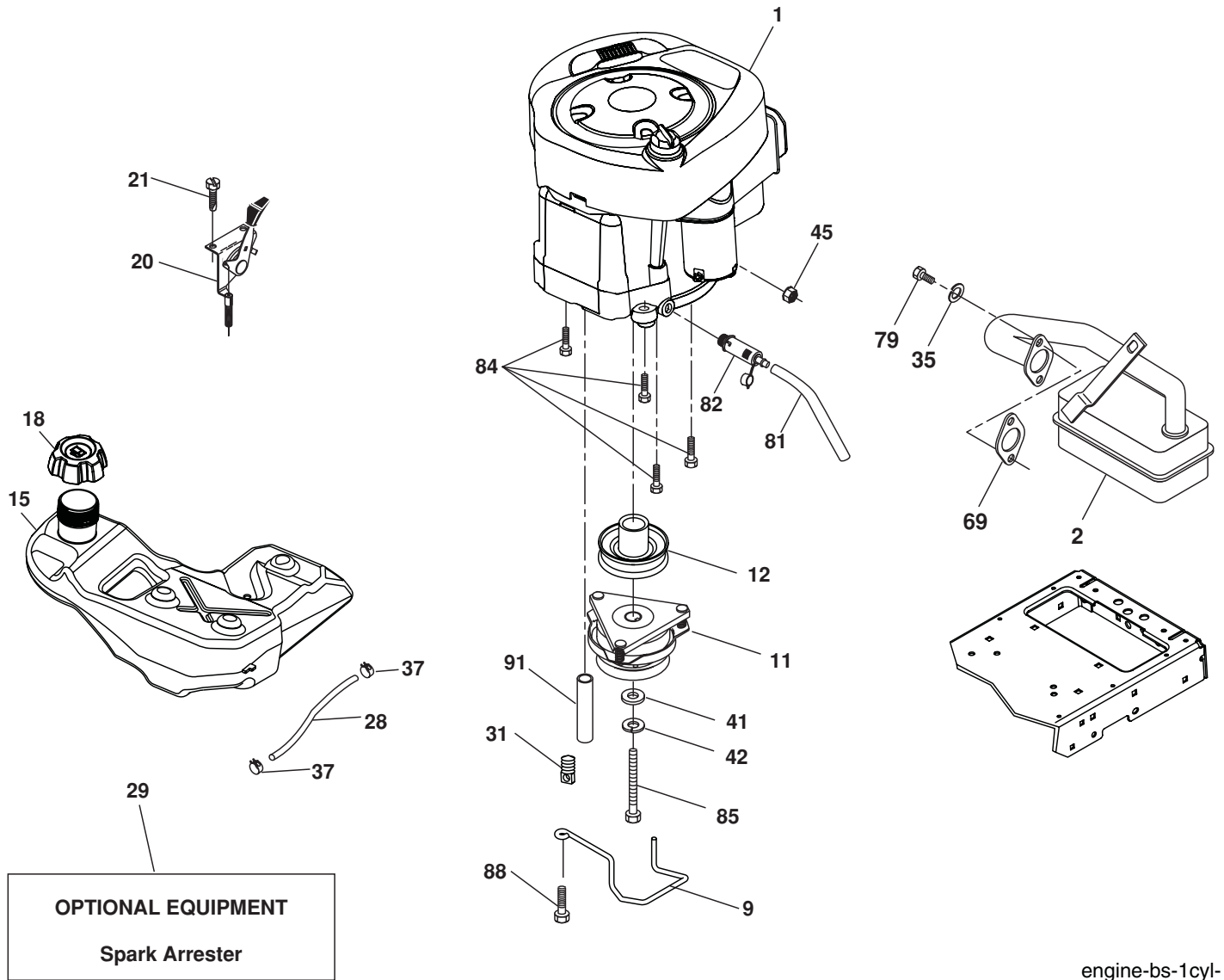

engine-bs-1cyl-

KEY NO.	PART NO.	DESCRIPTION
1	-----	Engine B&S Model No. 31P977
2	532 13-73-52	Muffler
9	532 19 43-19	Keeper Belt Engine
11	532 18 05-05	Clutch Ogura
12	532 19 43-38	Pulley Engine
15	532 40 00-21	Tank Fuel
18	532 19 42-67	Cap Asm
20	532 40 15-08	Control Throttle
28	532 40 11-35	Fuel Line
29	532 13 71-80	Spark Arrester Kit
31	532 14 50-06	Clip Push-In Hinged
34	817 72 04-08	Screw thd Cut 1/4-20 x 1/2
35	810 01 05-00	Washer Split
37	532 12 34-87	Clamp Hose
41	532 12 61-97	Washer 1-1/2 OD x 15/32 ID x .250
42	810 04 07-00	Washer Lock 7/16
45	873 51 04-00	Nut Keps Hex 1/4-20 unc

KEY NO.	PART NO.	DESCRIPTION
69	532 16 52-91	Gasket
79	532 19 23-34	Screw Socket Head 5/16-18 x .75
81	532 14 84-56	Tube Drain Oil Easy
82	532 18 16-54	Plug Drain Oil
84	817 06 06-20	Screw 3/8-16 x 1-1/4
85	532 17 39-37	Bolt Hex 7/16-20 x 4 x Gr. 5-1.5 Thr
88	817 06 06-16	Screw 3/8-16 x 1

**NOTE:** All component dimensions given in U.S. inches  
1 inch = 25.4 mm

For engine service and replacement parts, call the toll free number for your engine manufacturer listed below:

Briggs & Stratton	1-800-233-3723
Kohler Co.	1-800-544-2444
Tecumseh Products	1-800-558-5402
Honda Engines	1-800-426-7701
Kawasaki	1-949-460-5688

**TRACTOR -- MODEL NUMBER YTH20B42T (96043002003), PRODUCT NO. 960 43 00-20  
SEAT ASSEMBLY**

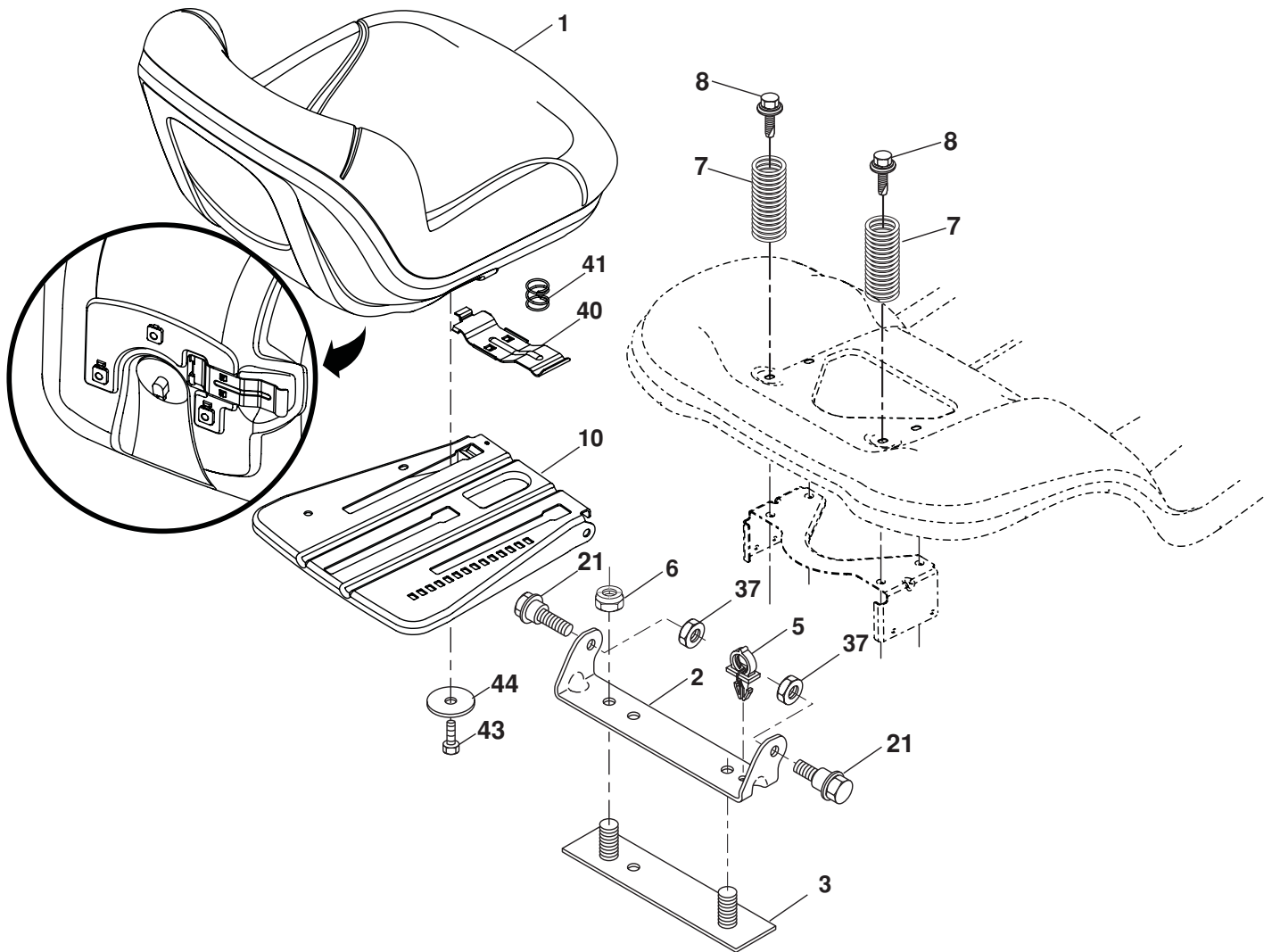

seat-tex\_7-vgt

KEY NO.	PART NO.	DESCRIPTION
1	532 19 75-18	Seat
2	532 18 01-66	Bracket Pivot Fender
3	532 14 06-75	Strap, Asm Fender
5	532 14 50-06	Clip, Push In, Hinged
6	873 80 06-00	Nut, Lock W/Ins. 3/8-16 unc
7	532 12 41-81	Spring, Seat Cprsn
8	532 17 18-77	Bolt 5/16-18 uncx 3/4 w/Sems
10	532 19 69-77	Pan, Seat

KEY NO.	PART NO.	DESCRIPTION
21	532 17 18-52	Bolt, Shoulder 5/16-18
37	873 80 05-00	Nut, Lock 5/16-18 unc
40	532 19 76-61	Handle Slide Seat
41	532 19 82-00	Spring Latch Seat
43	874760612	Bolt Fin Hex 3/8-16 unc x 3/4
44	819133812	Washer 13/32 x 2-3/8 x 12 Ga.

**NOTE:** All component dimensions given in U.S. inches  
1 inch = 25.4 mm

**TRACTOR -- MODEL NUMBER YTH20B42T (96043002003), PRODUCT NO. 960 43 00-20  
DECALS**

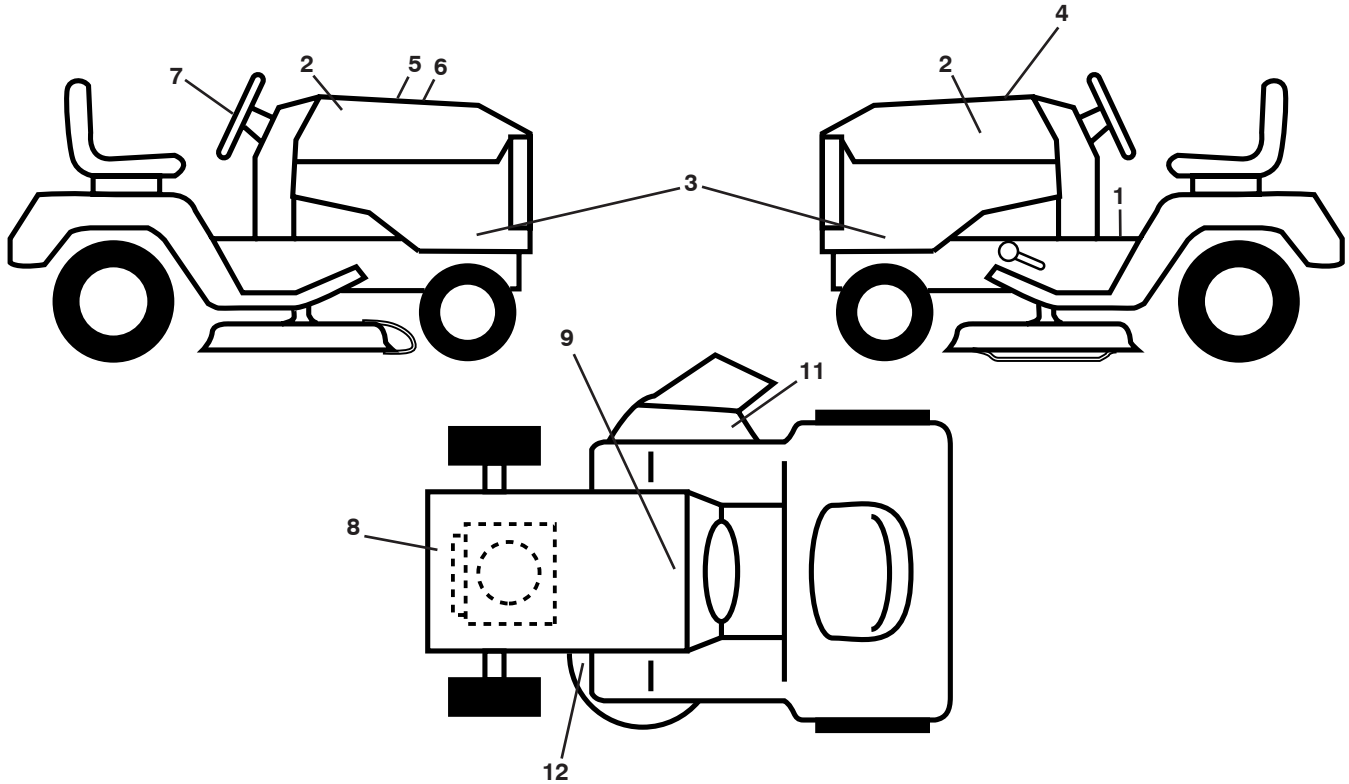

KEY NO.	PART NO.	DESCRIPTION
1	532 40 21-04	Decal, Operators
2	532 40 33-78	Decal, Hood
3	532 40 43-72	Decal, Hood Panel SD
4	532 40 21-28	Decal, Hood Top Insert
5	532 18 09-41	Decal, Customer Respons.
6	532 40 21-40	Decal, Replacement
7	532 18 89-25	Decal, Steering Wheel
8	532 40 24-92	Decal, Eng. HP

KEY NO.	PART NO.	DESCRIPTION
9	532 14 50-05	Decal, Battery Dnge/Poi
11	532 17 05-63	Decal, Warning
12	532 16 03-96	Decal, Mower V-Belt Schematic
--	532 16 69-60	Decal, Bypass
--	532 40 29-76	Pad, Footrest, LH
--	532 40 47-99	Pad, Foot Pedal Control
--	532 40 88-91	Manual, Owner's (English)
--	532 40 88-92	Manual, Owner's (French)

**WHEELS AND TIRES**

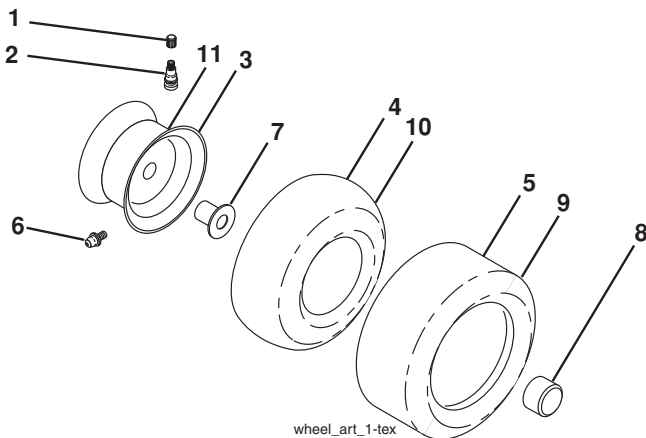

KEY NO.	PART NO.	DESCRIPTION
1	532 05 91-92	Cap Valve Tire
2	532 06 51-39	Stem Valve
3	532 13 83-36	Tire F T 15 x 6 0 - 6 Service
4	532 05 99-04	Tube Front (Service Item Only)
5	532 10 62-22	Rim Asm 6" front Service
6	532 12 49-57	Fitting Grease (Front Wheel Only)
7	532 12 49-59	Bearing Flange (Front Wheel nly)
8	532 17 50-39	Cap Axle Blk 1 50 x 1 00
9	532 13 84-68	Tire R T 18 x 9.5-8 Service
10	532 12 49-26	Tube Rear (Service Item Only)
11	532 13 83-37	Rim Asm 8" rear Service
--	532 14 43-34	Sealant, Tire (10 oz. Tube)

**NOTE:** All component dimensions given in U.S. inches  
1 inch = 25.4 mm

**TRACTOR -- MODEL NUMBER YTH20B42T (96043002003), PRODUCT NO. 960 43 00-20  
MOWER DECK**

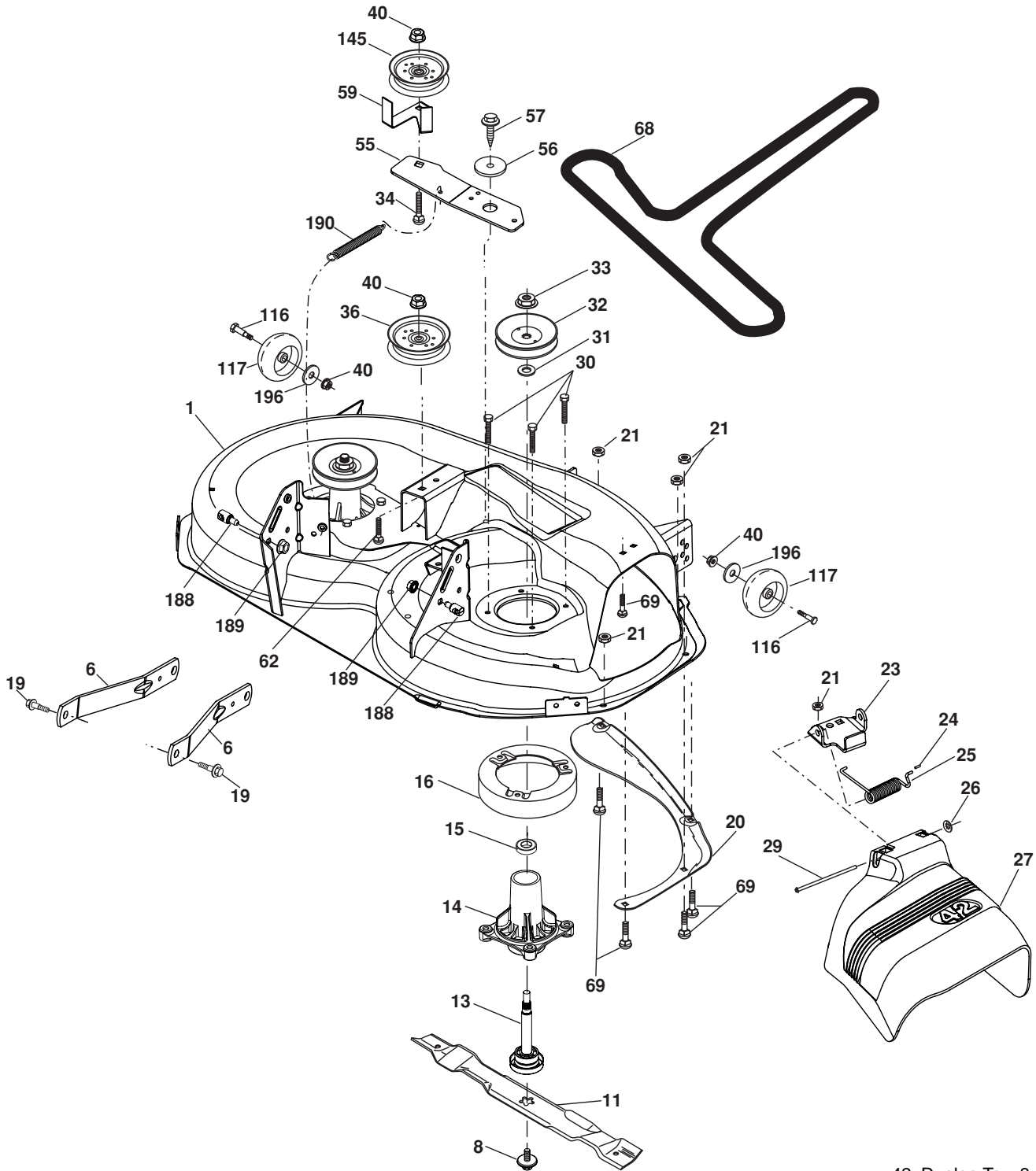

42\_D\_elec-TeX\_8

**TRACTOR -- MODEL NUMBER YTH20B42T (96043002003), PRODUCT NO. 960 43 00-20  
MOWER DECK**

KEY NO.	PART NO.	DESCRIPTION
1	532 40 29-99	Mower Housing
6	532 19 51-86	Arm Suspension
8	532 19 30-03	Bolt/Washer asm 7/16-20 unf
11	532 13 89-71	Blade, 42" Hi-Lift (For bagging or discharge)
--	532 13 41-49	Blade, 42" Mulching Std (For mulching mowers only)
--	532 13 97-75	Blade, 42" Mulching Premium (For better wear when mulching)
13	532 19 28-72	Shaft Assembly, Mandrel
14	532 18 72-81	Housing, Mandrel
15	532 11 04-85	Bearing, Ball, Mandrel
16	532 17 44-93	Stripper, Mower Deck
19	532 19 65-39	Bolt, Shoulder
20	532 15 97-70	Baffle, Vortex
21	873 68 05-00	Nut, Crownlock 5/16-18 unc
23	532 19 25-57	Bracket, Deflector
24	532 10 53-04	Cap, Sleeve
25	532 19 70-26	Spring, Torsion, Deflector
26	532 11 04-52	Nut, Push
27	532 40 30-04	Shield, Deflector
29	532 13 14-91	Rod, Hinge
30	532 17 39-84	Screw Thdrol Rolling Wsh Hd
31	532 18 76-90	Washer, Spacer
32	532 17 34-36	Pulley, Mandrel

KEY NO.	PART NO.	DESCRIPTION
33	532 40 02-34	Nut, Toplock, Flanged
34	872 11 06-12	Bolt Carr Sh. 3/8-16 x 1-1/2 Gr. 5
36	532 19 61-06	Pulley, Idler, Flat
40	873 90 06-00	Nut, Lock Flg. 3/8-16 unc
55	532 19 72-49	Arm, Idler
56	532 19 90-92	Spacer, Retainer
57	817 00 06-16	Screw 3/8-16 x 1
59	532 14 10-43	Guard, Tuv Idler
62	872 11 06-16	Bolt Rd Hd Sq Nk 3/8-16 unc x 2
68	532 14 49-59	V-Belt
69	872 14 05-05	Bolt
116	532 19 34-06	Bolt, Shoulder
117	532 17 48-73	Wheel, Gauge
145	532 17 79-68	Pulley Idler
188	532 19 51-61	Stud Fastener
189	873 90 05-00	Nut Lock Hex Flange
190	532 19 72-51	Spring Mower Drive
196	819 13 20-12	Washer 13/32 x 1-1/4 x 12 Ga.
--	532 19 28-70	Mandrel Assembly (Includes housing, shaft and shaft hardware only-pulley not included)
--	532 40 12-24	Replacement Mower, Complete

**NOTE:** All component dimensions given in U.S. inches  
1 inch = 25.4 mm

**TRACTOR -- MODEL NUMBER YTH20B42T (96043002003), PRODUCT NO. 960 43 00-20  
MOWER LIFT**

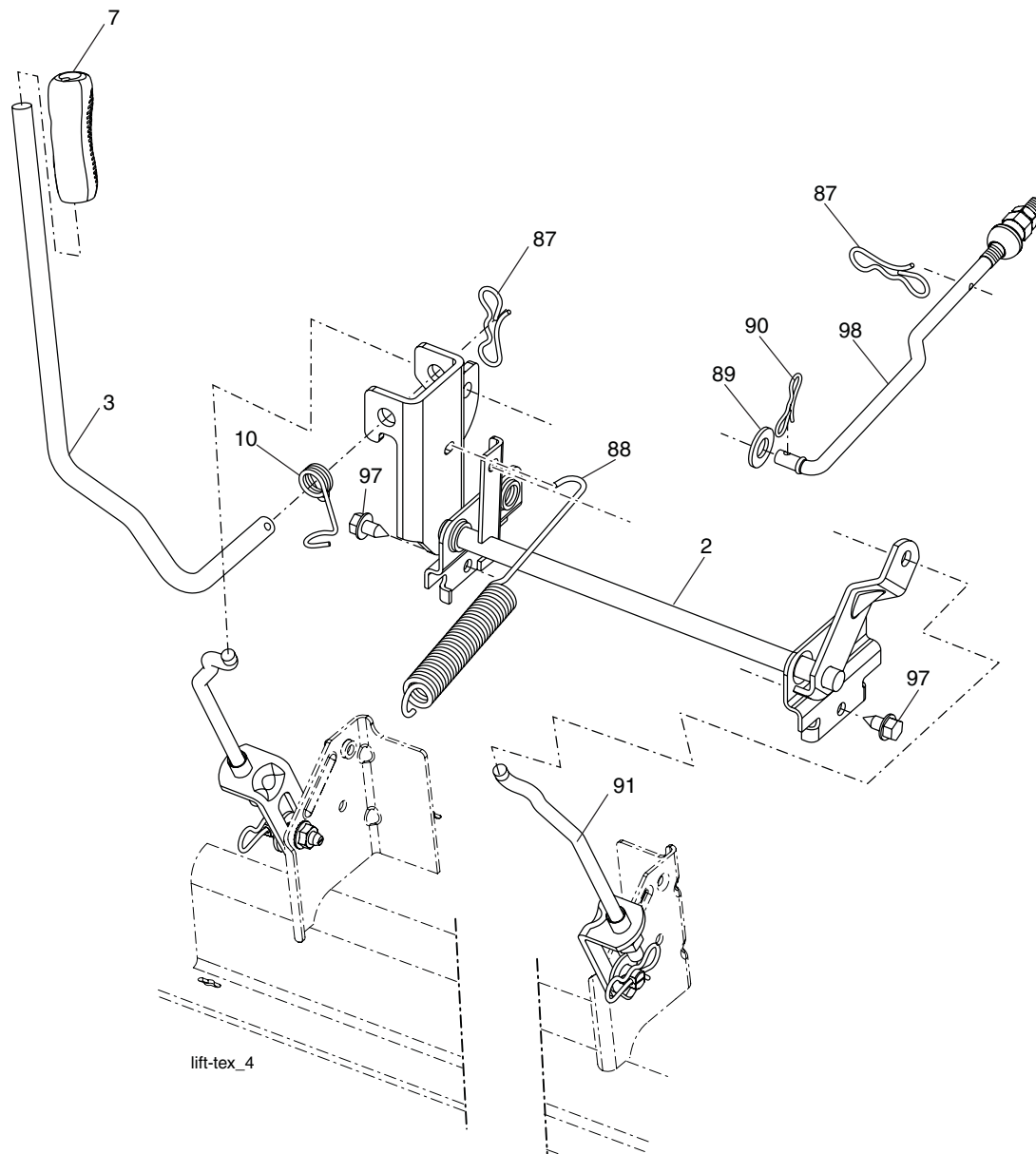

KEY NO.	PART NO.	DESCRIPTION
2	532 19 52-23	Shaft Asm., Lift
3	532 19 52-31	Lever Asm., Lift Rh
7	532 19 64-92	Grip, Lever
10	532 19 63-14	Spring Torsion
87	532 19 42-09	Pin Cotter 7/16 Bow Tie Lock
88	532 19 53-03	Spring Lift Assist
89	819 19 19-12	Washer Clear Zinc

KEY NO.	PART NO.	DESCRIPTION
90	532 19 42-08	Pin Cotter 5/16 Bow Tie Lock
91	532 19 51-81	Link Lift Susp Mower Rear
97	817 06 06-12	Screw 3/8-16 x .75 Smgml Tap/R.Z
98	532 19 52-70	Link Lift Susp. Front Mower

**NOTE:** All component dimensions given in U.S. inches  
1 inch = 25.4 mm