

# OWNERS MANUAL

Model No.  
486.24433  
486.24415

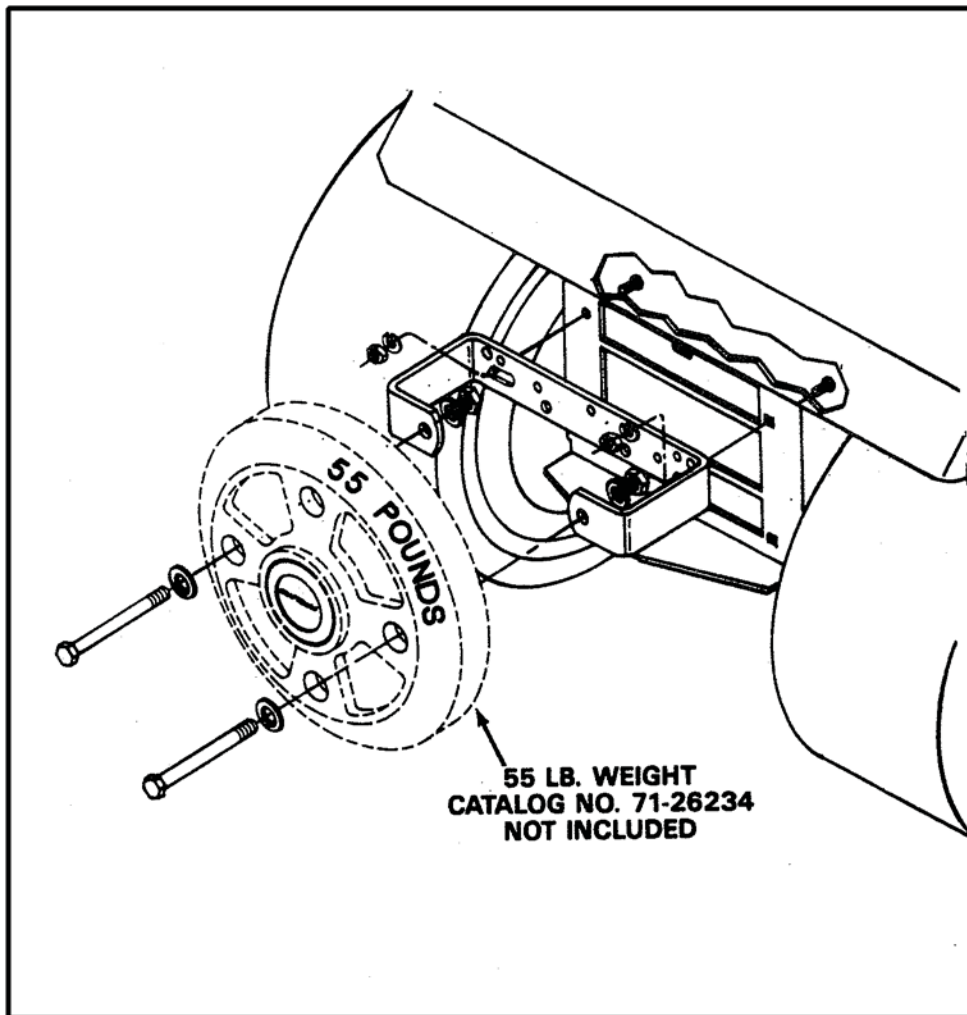

## WEIGHT BRACKET KIT

- Assembly
- Operation
- Customer Responsibilities
- Repair Parts



# RULES FOR SAFE OPERATION

Any power equipment can cause injury if operated improperly or if the user does not understand how to operate the equipment.

Exercise caution at all times, when using power equipment.

1. Refer to your tractor owners manual for "Rules For Safe Operation."
2. Do not use more than one 55lb. weight (Catalog No. 71-26234) with this bracket.

3. Use 55 lb. weight for snow removal or tilling only.
4. Weight must be removed when mower deck is reinstalled.



LOOK FOR THIS SYMBOL TO POINT OUT IMPORTANT SAFETY PRECAUTIONS. IT MEANS --- ATTENTION. BECOME ALERT. YOUR SAFETY IS INVOLVED.

Your weight bracket kit carton contains parts as shown in figure 1. The hardware package contains parts shown in figure 2. Identify all parts and lay out as shown in figures 1 and 2.

## CARTON CONTENTS

1. #24215 Weight Bracket
2. Hardware Package (shown at bottom)

## CARTON CONTENTS

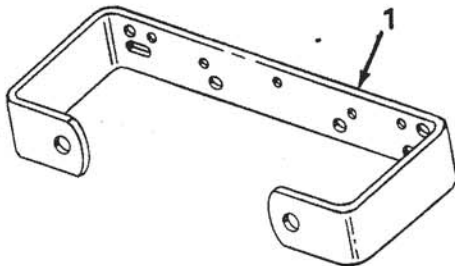

FIGURE 1

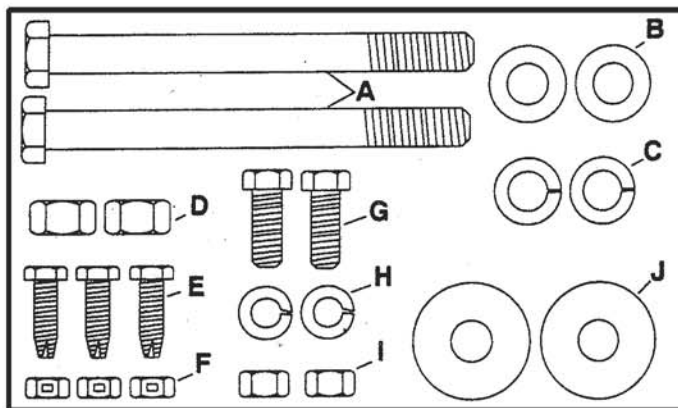

FIGURE 2

## ASSEMBLY INSTRUCTIONS TO MOUNT WEIGHT AT REAR FOR SNOW REMOVAL

### TOOLS REQUIRED FOR ASSEMBLY

- (2) 1/2" Open or Boxed End Wrench.
- (2) 9/16" Open or Boxed End Wrench.
- (1) 3/4" Open or Boxed End Wrench.
- (1) Ratchet Wrench With 3/4" Socket.

## CONTENTS OF HARDWARE PACKAGE (Figure 2)

REF.	PART NO.	QTY.	DESCRIPTION
A	R74760884	2	Hex Bolt, 1/2-13 x 5-1/2" Lg.
B	R19171616	2	Flat Washer, 17/32" x 1" O.D.
C	43353	2	Lock Washer, 1/2" I.D.
D	712-0106	2	Hex Nut, 1/2-13 Thd.
E	44283	3	Hex Bolt, 5/16-18 x 1" Thread Cutting
F	43064	3	Hex Lock Nut, 5/16-18
G	43001	2	Hex Bolt, 3/8-16 x 1" Lg.
H	43003	2	Lock Washer, 3/8" H.D.
I	43015	2	Hex Nut, 3/8-16
J	R19172410	2	Flat Washer, 17/32 x 1-1/2 O.D.

1. Assemble two 1-1/2" O.D. flat washers (Ref. J) onto two 3/8-16 x 1" hex bolts (Ref. G). Insert bolts through drawbar and assemble weight bracket onto bolts. Fasten securely with two 3/8" lock washers (Ref. H) and two 3/8-16 hex nuts (Ref. I). See figure 3.
2. Assemble wheel weight to mounting bracket using two 1/2" x 5-1/2" long hex bolts (Ref. A), two 1" O.D. flat washers (Ref. B), two 1/2" lock washers (Ref. C), and two 1/2-13 hex nuts (Ref. D). Tighten securely. See figure 3.

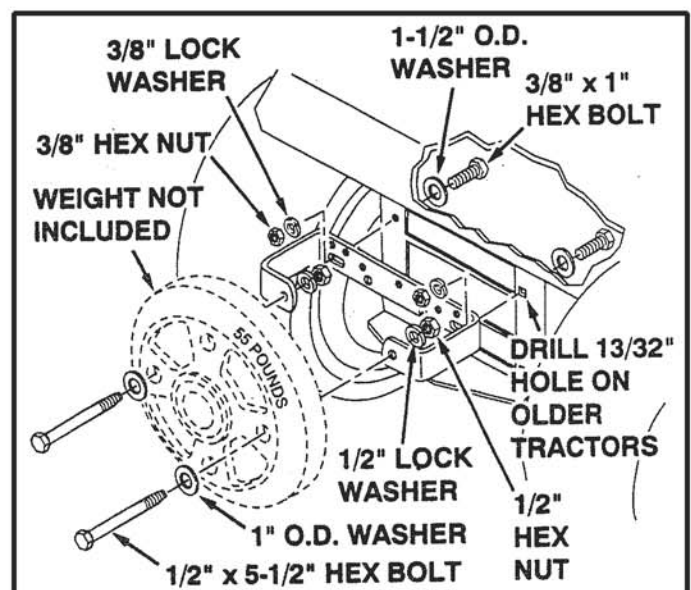

FIGURE 3



USE CAUTION — WHEEL WEIGHTS ARE HEAVY AND AWKWARD TO HANDLE.



**Please do not return this product to the Store**

**For Missing Parts Or Questions on How to Assemble:**

1. Call Agri-Fab at 1-800-448-9282 Option # 1  
Monday through Friday, 7 am to 5 pm CST
2. Fax Agri-Fab at 217-728-2032 or email [info@agri-fab.com](mailto:info@agri-fab.com)

*Missing part shipments are normally shipped from the Agri-Fab factory within 24 hours zip code 61951. 1 to 5 days delivery for UPS.*

**For Replacement and/or Repair Parts:**

1. Call Agri-Fab at 1-800-448-9282 Option # 1  
Monday through Friday, 7 am to 5 pm CST
2. Visit Agri-Fab's website at <http://www.agri-fab.com> and view illustrated parts breakdowns and parts listing and purchase parts via our <http://www.speedepart.com> site online.