

Operator's manual

BZ 27

BZ 34

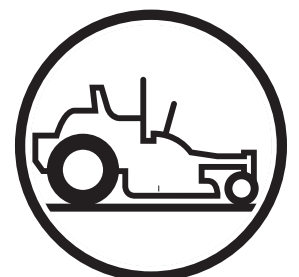

Please read these instructions carefully and make sure you understand them before using the machine.

English

OPERATOR'S MANUAL

RIDER

BZ SERIES

Contents

Contents	1	Maintenance	36
Introduction	3	Maintenance Schedule.....	36
Congratulations.....	3	Battery.....	38
General	3	Checking the Safety System	39
Driving and Transport on Public Roads	3	Checking the Engine's Cooling Air Intake	40
Towing	3	Clutch Service	40
Operating	3	Checking and Adjusting the Throttle Cable.....	40
Good Service	4	Air filter maintenance	41
Manufacturing Number	4	Replacing the Fuel Filter	43
Symbols and Decals	5	Checking Tire Pressures.....	43
Safety Instructions	7	Checking and Filling Coolant	43
General Use.....	7	Checking the Parking Brake.....	45
Personal Safety Equipment	9	Checking the V-belts	46
Driving on Slopes.....	10	Checking the Blades	47
Children.....	11	Adjusting the Mower Deck	49
Maintenance	12	Checking Hydraulic System	51
Transport.....	15	Motion Control Linkage Adjustment	52
Customer responsibilities.....	16	Deck Lift Power Unit.....	53
Controls	17	Mule Drive System	53
Control Locations	17	Caster Wheels.....	53
Gauges	18	Cleaning and Washing	54
Throttle Control	18	Hardware	54
Ignition	18	Lubrication	55
Hour Meter	18	Lubrication Schedule.....	55
Engaging the Mower Deck.....	19	General	55
Parking Brake	19	Lubricating the Cables	56
Seat Adjustment.....	19	Shaft Bushings and Linkage	56
Motion Control Levers.....	20	Lubricating in Accordance with the Lubrication	
Hydraulic Lift Switch.....	21	Schedule	56
Refueling.....	22	Trouble Shooting Guide	62
Fuel Shut-Off.....	22	Storage	65
Fuses	22	Winter Storage	65
Hydraulic Lift for Mower Deck.....	23	Service	65
Lifting Lever for the Mower Deck (Manual)	23	Wiring diagram	66
Relays	24	Technical Data	67
Tracking	24	Accessories	69
Accessories.....	24	Torque Specifications.....	69
Operation	25	Conformity Certificates	70
Before Starting	26	EU declaration of conformity	70
Starting the Engine	26	Service Journal	71
To start an engine with a weak battery	29	Delivery Service	71
Running.....	30	25-Hour Service	73
Operating on hills	32	50-Hour Service	74
Mowing Tips.....	33	100-Hour Service	75
Stopping the Engine.....	34	300-Hour Service	76
Moving by Hand	35	At Least Once Each Year.....	77



WARNING!

Failure to follow cautious operating practices can result in serious injury to the operator or other persons. The owner must understand these instructions, and must allow only trained persons who understand these instructions to operate the mower. Each person operating the mower must be of sound mind and body and must not be under the influence of any mind altering substance.

INTRODUCTION

Introduction

Congratulations

Thank you for purchasing a Husqvarna ride-on mower. This machine is built for the greatest efficiency and rapid mowing primarily of large areas. Controls in one place and a hydrostatic transmission regulated by steering controls also contribute to the machine's performance.

This manual is a valuable document. Following the instructions (use, service, maintenance, etc.) by all who operate this machine can considerably increase the lifespan of your machine and even increase its resale value. It is also very important to follow the instructions for the safety of you and others.

If you sell your machine, be sure to give the operator's manual to the new owner.

The final chapter of this operator's manual comprises a Service Journal. Ensure that service and repair work is documented. A well kept service journal reduces service costs for the season-based maintenance and affects the machine's resale value. Take the operator's manual along when the machine is left at the workshop for service.

General

In this operator's manual, left and right, backward and forward are used in relation to the machine's normal driving direction.

Continuous dedication to improve our products require that specifications and design are subject to change without notice.

Driving and Transport on Public Roads

Check applicable road traffic regulations before transporting on public roads. If the machine is transported, you must always use approved fastening equipment and ensure that the machine is well anchored. DO NOT operate this machine on public roadways.

Towing

Do not tow this machine, it may cause damage to the drive system.

Do not tow any trailers, etc with this mower. They may jackknife or overturn causing damage to the mower and possibly serious injury to the operator.

Operating

This machine is constructed only for mowing grass on lawns and other free and even ground without obstacles such as stones, tree stumps, etc. The machine can also be used for other tasks when equipped with special accessories provided by the manufacturer, for which the operating instructions are provided in conjunction with delivery. All other types of use are incorrect. The manufacturer's directions concerning operation, maintenance, and repairs must be carefully followed.

Lawnmowers and all power equipment, can be potentially dangerous if used improperly. Safety requires good judgement, careful use in accordance with these instructions and common sense.

The machine must only be operated, maintained, and repaired by persons that are familiar with the machine's special characteristics and who are well versed in the safety instructions. Use only approved repair parts to maintain this machine.

Accident prevention regulations, other general safety regulations, occupational safety rules, and traffic regulations must be followed without fail.

Unauthorized modifications to the design of the machine may absolve the manufacturer from liability for any resulting personal injury or property damage.

INTRODUCTION

Good Service

Husqvarna's products are sold all over the world and only in specialized retail stores with complete service. This ensures that you as a customer receive only the best support and service. Before the product is delivered, the machine has, for example, been inspected and adjusted by your retailer, see the certificate in the Service Journal in this operator's manual.

When you need spare parts or support in service questions, warranty issues, etc., please consult the following professional:

This Operator's Manual belongs to the machine with manufacturing number:	Engine	Transmission

Manufacturing Number

The machine's manufacturing number can be found on the printed plate affixed to the left in the engine compartment. Stated on the plate, from the top are:

- The machine's type designation (I.D.).
- The manufacturer's type number (Model).
- The machine's serial number (Serial no.)

Please state the type designation and serial number when ordering spare parts.

The engine's manufacturing number is stated on a barcode decal. This is placed on the left side of the crankcase, in front of the starter. The plate states:

- The engine's serial number (E/NO).
- The engine's type designation (Code).

Please state these when ordering spare parts.

The hydraulic pump's manufacturing number is stated on a barcode decal affixed to the left side of the pump housing. The plate states:

- The pump's type designation.
- The pump's serial number.

The hydraulic motor's manufacturing number is stated on a round metal plate. This is placed on the gable inside the motor. The plate states:

- The hydraulic motor's type designation and design version.
- The hydraulic motor's serial number.

SYMBOLS AND DECALS

Symbols and Decals

These symbols are found on the machine and in the operator's manual. Study them carefully so that you know what they mean.



Used in this publication to notify the reader of a risk of **personal injury or death**, particularly if the reader should neglect to follow instructions given in the manual.



Used in this publication to notify the reader of a risk of **material damage**, particularly if the reader should neglect to follow instructions given in the manual. Used also when there is a potential for misuse or misassembly.

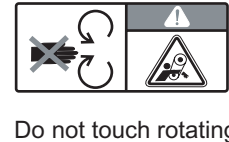
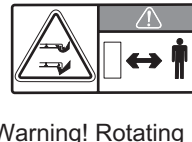
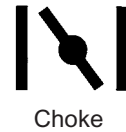

SYMBOLS AND DECALS

Read
Operator's
Manual.

Shut off engine
and remove key
before
performing any
maintenance or
repair work.

Keep a safe
distance from
the machine.

Use on
slopes no
greater
than 10°.

No
passengers.

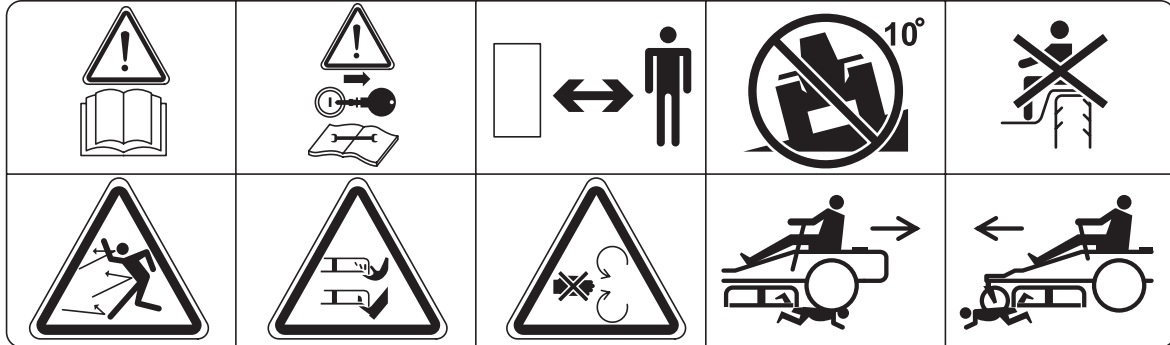

Whole body
exposure to
thrown
objects.

Severing of
fingers and
toes.

Do not open
or remove
safety shields
while engine
is running.

Careful
backing up,
watch for other
people.

Careful going
forward, watch
for other people.

SAFETY INSTRUCTIONS

Safety Instructions

These instructions are for your safety. Read them carefully.



WARNING!

This symbol means that important safety instructions need to be emphasized. It concerns your safety.

IMPORTANT: THIS CUTTING MACHINE IS CAPABLE OF AMPUTATING HANDS AND FEET AND THROWING OBJECTS. FAILURE TO OBSERVE THE FOLLOWING SAFETY INSTRUCTIONS COULD RESULT IN SERIOUS INJURY OR DEATH.

General Operation

- Read, understand, and follow all instructions on the machine and in the manual before starting.
- Do not put hands or feet near rotating parts or under the machine. Keep clear of the discharge opening at all times.
- Only allow responsible adults, who are familiar with the instructions, to operate the machine.
- Clear the area of objects such as rocks, toys, wire, etc., which could be picked up and thrown by the blades.
- Be sure the area is clear of bystanders before operating. Stop machine if anyone enters the area.
- Never carry passengers. The machine is only intended for use by one person.
- Do not mow in reverse unless absolutely necessary. Always look down and behind before and while backing.
- Never direct discharged material toward anyone. Avoid discharging material against a wall or obstruction. Material may ricochet back toward the operator. Stop the blades when crossing gravel surfaces.
- Do not operate machine without the entire grass catcher, discharge guard, or other safety devices in place and working.
- Slow down before turning.
- Never leave a running machine unattended. Always turn off blades, set parking brake, stop engine, and remove keys before dismounting.

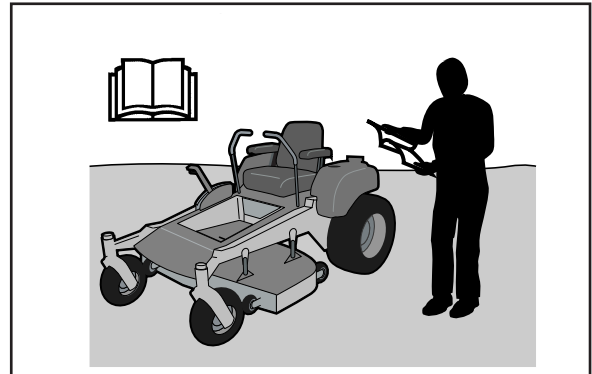

8011-512

Read the operator's manual before starting the machine

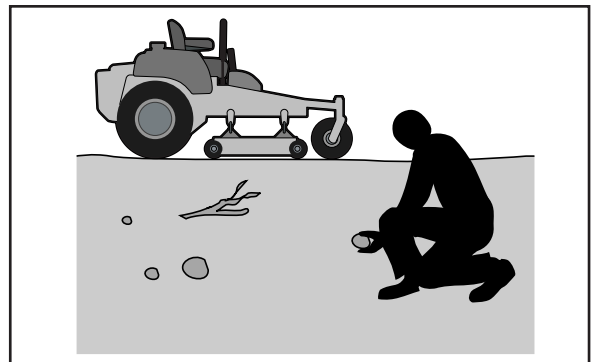

8011-513

Clear the area of objects before mowing



8011-520

Never take passengers

SAFETY INSTRUCTIONS

- Disengage blades when not mowing. Shut off engine, wait for all parts to come to a complete stop, and remove ignition key before cleaning the machine, removing the grass catcher, or unclogging the discharge guard.
- Operate machine only in daylight or good artificial light.
- Do not operate the machine while under the influence of alcohol or drugs.
- Watch for traffic when operating near or crossing roadways.
- Use extra care when loading or unloading the machine into a trailer or truck.
- Always wear eye protection when operating machine.
- Data indicates that operators, age 60 years and above, are involved in a large percentage of riding mower-related injuries. These operators should evaluate their ability to operate the riding mower safely enough to protect themselves and others from serious injury.
- Follow the manufacturer's recommendation for wheel weights or counterweights.
- Anyone who operates this machine must first read and understand this Operation Manual. Local laws may regulate the age of the user.
- Keep machine free of grass, leaves or other debris build-up which can touch hot exhaust / engine part and burn. Do not allow the mower deck to plow leaves or other debris which can cause build-up to occur. Clean any oil or fuel spillage before operating or storing the machine. Allow machine to cool before storage.
- After striking object or if abnormal machine vibration is present, disengage drive to attachments, stop engine, remove ignition key, and check immediately. Inspect the machine for damage and make repairs before restarting and operating equipment.
- Keep in mind that the operator or user is responsible for accidents or hazards occurring to other people or their property.



WARNING!

Engine exhaust and certain vehicle components contain or emit chemicals considered to cause cancer, birth defects, or other reproductive system damage. The engine exhaust contains carbon monoxide, which is a odorless, colorless, poisonous gas. Do not use the machine in enclosed spaces.

SAFETY INSTRUCTIONS

- All drivers should seek and obtain professional and practical instruction. Such instructions should emphasize:
 1. the need for care and concentration when working with ride-on machine;
 2. control of a ride-on machine sliding on a slope will not be regained by the application of the brake. The main reasons for loss of control are:
 - a. insufficient wheel grip;
 - b. being driven too fast;
 - c. inadequate braking;
 - d. the type of machine is unsuitable for its task;
 - e. lack of awareness of the effect of ground conditions, especially slopes;
 - f. incorrect hitching and load distribution.
- Watch out for traffic when crossing or near roadways.
- Stop the blades rotating before crossing surfaces other than grass.

Personal Safety Equipment



WARNING!

When using the machine, approved personal protective equipment (shown in illustrations) shall be used. Personal protective equipment cannot eliminate the risk of injury but it will reduce the degree of injury if an accident does happen. Ask your retailer for help in choosing the right equipment.

- Make sure that you have first aid equipment close at hand when using the machine.
- Never use the machine when barefoot. Always wear protective shoes or boots, preferably with steel toecaps.
- Always wear approved protective glasses or a full visor when assembling or driving.
- Always wear gloves when handling the blades.
- Never wear loose clothing that can get caught in moving parts.
- Use ear protectors to avoid damage to hearing.
- While mowing, always wear substantial footwear and long trousers. Do not operate the equipment when barefoot or wearing open sandals.

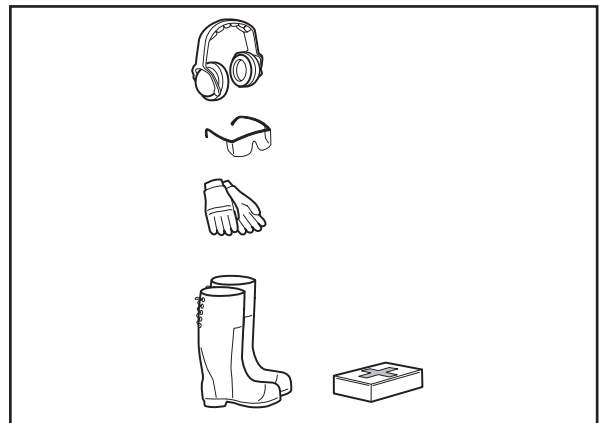

SAFETY INSTRUCTIONS

Slope Operation

Slopes are a major factor related to loss of control and tip-over accidents, which can result in severe injury or death. Operation on all slopes requires extra caution. If you cannot back up the slope or if you feel uneasy on it, do not mow it.

- Mow up and down slopes (10 degrees maximum), not across.
- Watch for holes, ruts, bumps, rocks, or other hidden objects. Uneven terrain could overturn the machine. Tall grass can hide obstacles.
- Choose a low ground speed so that you will not have to stop while on the slope.
- Do not mow on wet grass. Tires may lose traction.
- Avoid starting, stopping, or turning on a slope. If the tires lose traction, disengage the blades and proceed slowly straight down the slope.
- Keep all movement on the slopes slow and gradual. Do not make sudden changes in speed or direction, which could cause the machine to roll over.
- Use extra care while operating machine with grass catchers or other attachments; they can affect the stability of the machine. Do not use on steep slopes.
- Do not try to stabilize the machine by putting your foot on the ground.
- Do not mow near drop-offs, ditches, or embankments. The machine could suddenly roll over if a wheel is over the edge or if the edge caves in.



8011-519

Be extra cautious when driving on slopes

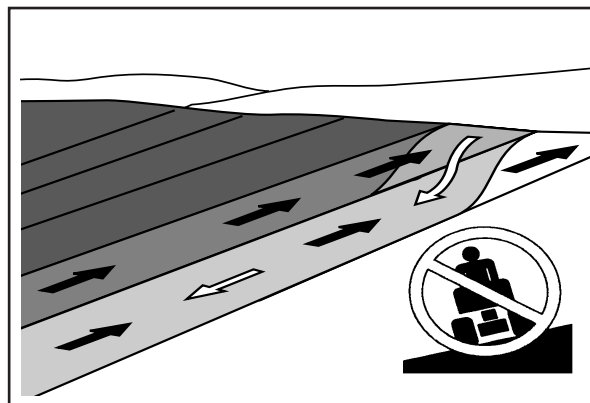
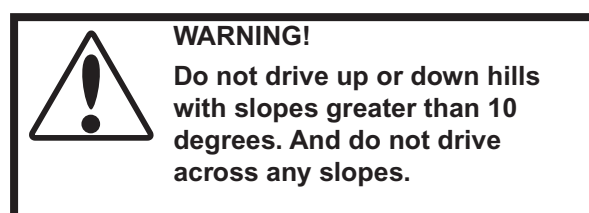

6003-004

Mow up and down, not side-to-side

SAFETY INSTRUCTIONS

Children

Tragic accidents can occur if the operator is not alert to the presence of children. Children are often attracted to the machine and the mowing activity. *Never* assume that children will remain where you last saw them.

- Keep children out of the mowing area and in the watchful care of a responsible adult other than the operator.
- Be alert and turn machine off if a child enters the area.
- Before and while backing, look behind and down for small children.
- Never carry children, even with the blades shut off. They may fall off and be seriously injured or interfere with safe machine operation. Children who have been given rides in the past may suddenly appear in the mowing area for another ride and be run over or backed over by the machine.

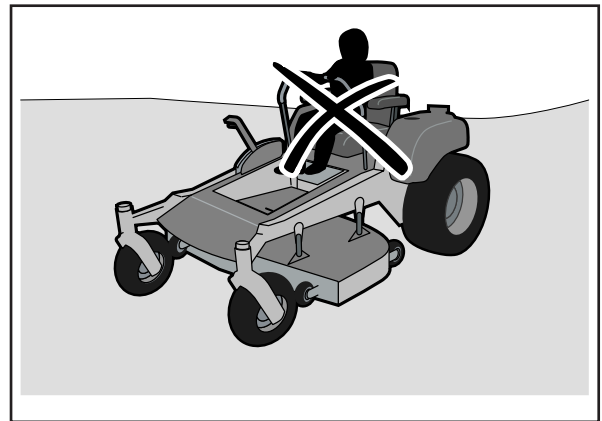

8011-517

Never allow children to operate the machine

- Never allow children to operate the machine.
- Use extra care when approaching blind corners, shrubs, trees, or other objects that may block your view of a child.



8011-518

Keep children away from the work area

SAFETY INSTRUCTIONS

Maintenance



WARNING!

The engine must not be started when the driver's floor plate or any protective plate for the mower deck's drive belt is removed.

Safe Handling of Gasoline

To avoid personal injury or property damage, use extreme care in handling gasoline.

Gasoline is extremely flammable and the vapors are explosive.

- Extinguish all cigarettes, cigars, pipes, and other sources of ignition.
- Use only approved gasoline container.
- Never remove gas cap or add fuel with the engine running. Allow engine to cool at least two (2) minutes before refueling.
- Never fuel the machine indoors.
- Never store the machine or fuel container where there is an open flame, spark, or pilot light such as on a water heater or other appliances.
- Before you begin refueling, minimize the risk of static electricity by touching a metal surface.
- Never fill containers inside a vehicle or on a truck or trailer bed with plastic liner. Always place containers on the ground away from your vehicle when filling.
- Remove gas-powered equipment from the truck or trailer and refuel it on the ground. If this is not possible, then refuel such equipment with a portable container, rather than from a gasoline dispenser nozzle.
- Keep the nozzle in contact with the rim of the fuel tank or container opening at all times until fueling is complete. Do not use a nozzle lock-open device.
- If fuel is spilled on clothing, change clothing immediately.
- Never overfill fuel tank. Replace gas cap and tighten securely.
- Do not start the engine near spilled fuel.
- Never use gasoline as a cleaning agent.
- If leaks arise in the fuel system, the engine must not be started until the problem has been resolved.

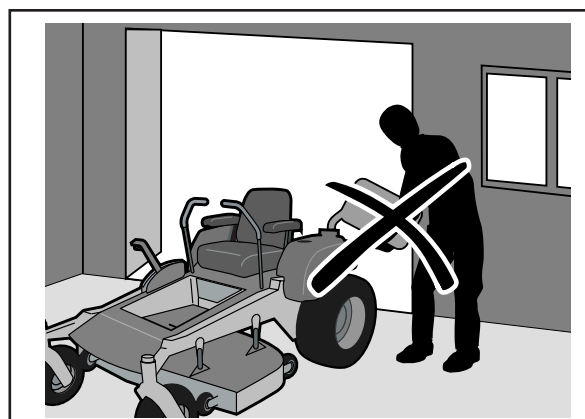

8011-516

Never fill the fuel tank indoors



WARNING!

The engine and the exhaust system, become very hot during operation.

Risk for burns if touched.

Allow engine and exhaust system to cool at least two (2) minutes before refueling

SAFETY INSTRUCTIONS

- Check the fuel level before each use and leave space for the fuel to expand, because the heat from the engine and the sun may otherwise cause the fuel to expand and overflow.

General Maintenance

- Never operate machine in a closed area.
- Keep all nuts and bolts tight to be sure the equipment is in safe working condition.
- Never tamper with safety devices. Check their proper operation regularly.
- Keep machine free of grass, leaves, or other debris build-up. Clean oil or fuel spillage and remove any fuel-soaked debris. Allow machine to cool before storing.
- If you strike a foreign object, stop and inspect the machine. Repair, if necessary, before restarting.
- Never make any adjustments or repairs with the engine running. Remove ignition key while making adjustments or repairs.
- Check grass catcher components and the discharge guard frequently and replace with manufacturer's recommended parts, when necessary.
- Mower blades are sharp. Wrap the blade or wear gloves, and use extra caution when servicing them.
- Check brake operation frequently. Adjust and service as required.
- Maintain or replace safety and instruction labels, as necessary.
- Do not modify safety equipment. Check regularly to be sure it works properly. The machine must not be driven with defective or unmounted protective plates, protective cowlings, safety switches, or other protective devices.
- Do not change the settings of governors and avoid running the engine with overly high engine speeds. If you run the engine too fast, you risk damaging the machine components.
- Be very careful when handling battery acid. Acid on skin can cause serious corrosive burns. If you spill battery acid on your skin, rinse immediately with water.

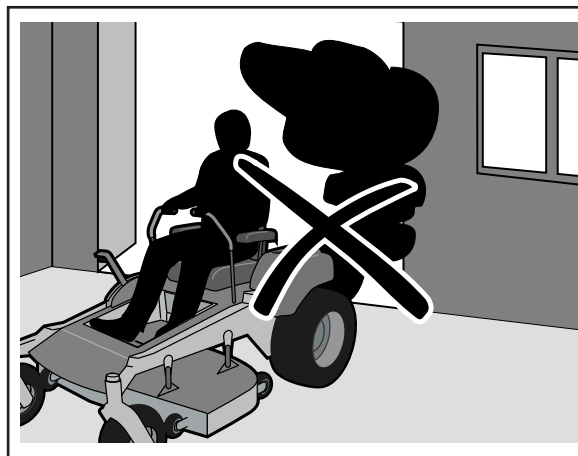

8011-515

Never drive the machine in an enclosed space



Always use protective glasses when handling the battery.



WARNING!

The battery contains lead and lead compounds, chemicals that are considered to cause cancer, birth defects, and other reproductive system damage. Wash your hands after handling the battery.

SAFETY INSTRUCTIONS

- Acid in the eyes can cause blindness, contact a doctor immediately.
- Be careful when servicing the battery. Explosive gases form in the battery. Never perform maintenance on the battery when smoking or near open flames or sparks. The battery can explode and cause serious injury/damage.
- Ensure that nuts and bolts, especially the fastening bolts for the blade attachments, are properly tightened, torqued and that the equipment is in good condition.
- Do not modify safety equipment. Check regularly to be sure it works properly. The machine must not be driven with defective or unmounted protective plates, protective cowlings, safety switches, or other protective devices.
- Do not change the settings of governors and avoid running the engine with overly high engine speeds. If you run the engine too fast, you risk damaging the machine components.
- Sparking can occur when working with the battery and the heavy cables of the starter circuit. This can cause battery explosion, fire or eye injury. Sparking in this circuit can not occur after the chassis cable (normally negative, black) is removed from the battery.

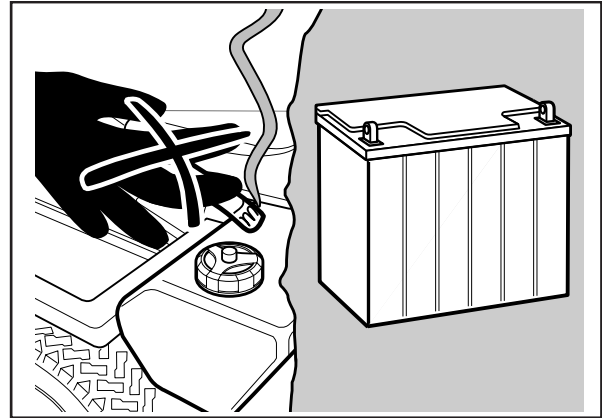

6003-009

Do not smoke when performing maintenance on the battery. The battery can explode and cause serious injury/damage

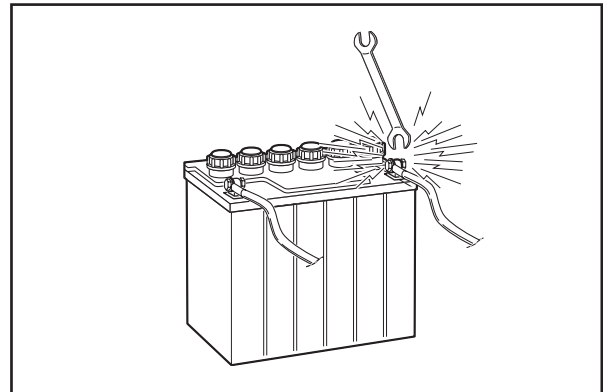

8009-728

Risk of sparking



WARNING!

Avoid electrical sparking and its consequences by the following routines:

- Use protective goggles.
- Ensure that the fuel filler cap is mounted tightly and no flammable substances is stored in an open vessel.
- Never work with the starter circuit if there is spilled fuel.
- Disconnect the chassis cable from the battery first and reconnect it last.
- Do not make a bridge short circuit across the starter relay to run the starter.
- Never use the machine indoors or in spaces lacking proper ventilation. The exhaust fumes contain carbon monoxide, an odorless, poisonous, and lethal gas.

SAFETY INSTRUCTIONS

- Stop and inspect the equipment if you run over or into anything. If necessary, make repairs before starting.
- Never make adjustments with the engine running.
- The machine is tested and approved only with the equipment originally provided or recommended by the manufacturer. Only use approved repair parts for the machine.
- The blades are sharp and can cause cuts and gashes. Wrap the blades or use protective gloves when handling them.
- Check the parking brake's functionality regularly. Adjust and service as necessary.
- The mulch blades should only be used in familiar areas when higher quality mowing is desired.
- Reduce the risk of fire by removing grass, leaves, and other debris that may have accumulated on the machine. Allow the machine to cool before putting it in storage.
- Regularly clean deck and underside of deck, avoid spraying engine and electrical components with water.
- On multi-bladed machines, take care as rotating one blade can cause other blades to rotate.



8011-644

Clean the machine regularly

Transport

- The machine is heavy and can cause serious crushing injuries. Be extra cautious when it is loaded on or unloaded from a vehicle or trailer.
- Use an approved trailer to transport the machine. Activate the parking brake, turn off the fuel supply, and fasten the machine with approved fastening devices, such as bands, chains, or straps, when transporting.
- Do not operate this machine on public roadways.
- Check and abide by local traffic regulations before transporting the machine on any road.
- Do not tow this machine, it may cause damage to the drive system.

IMPORTANT INFORMATION

The parking brake is not sufficient to lock the machine in place during transport. Ensure that the machine is well fastened to the transport vehicle. Always reverse the machine onto the transport vehicle to avoid tipping it over.

SAFETY INSTRUCTIONS

- Do not tow any trailers, etc. with this mower. They may jackknife or overturn causing damage to the mower and possibly serious injury to the operator.
- When machine is to be parked, stored or left unattended, lower the cutting means unless a positive mechanical lock is used.

Customer responsibilities

- Read and observe the safety rules.
- Follow a regular schedule in maintaining, caring for and using your mower.
- Follow the instructions under "Maintenance" and "Storage" sections of this owner's manual.
- This machine has no brain. Use yours!



WARNING!

This mower is equipped with an internal combustion engine and should not be used on or near any unimproved forest-covered, bush-covered or grass-covered land unless the engine's exhaust system is equipped with a spark arrester meeting applicable local or state laws (if any). If a spark arrester is used, it should be maintained in effective working order by the operator.

A spark arrester for the muffler is available through your authorized Husqvarna dealer.

CONTROLS

Controls

This operator's manual describes the Husqvarna Zero Turn Rider. The mower is fitted with a liquid cooled, 3 cylinder Daihatsu diesel engine (27 HP) or Daihatsu Turbo diesel engine (34 HP)

Transmission from the engine is made via two belt-driven hydrostat transaxles, which in turn drive a hydraulic motor for each drive wheel. Using the left and right steering controls, the flow is regulated and thereby the direction and speed.

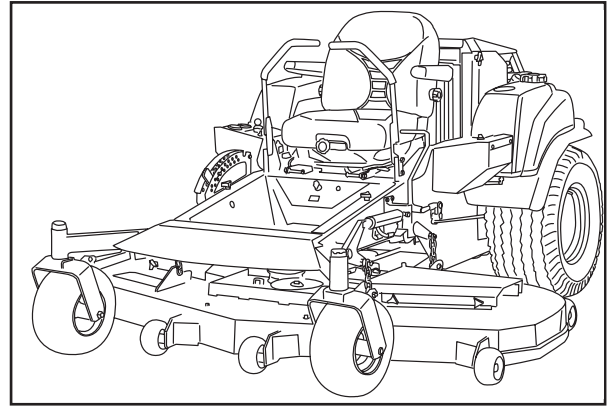

BAM-1

Zero Turn Rider

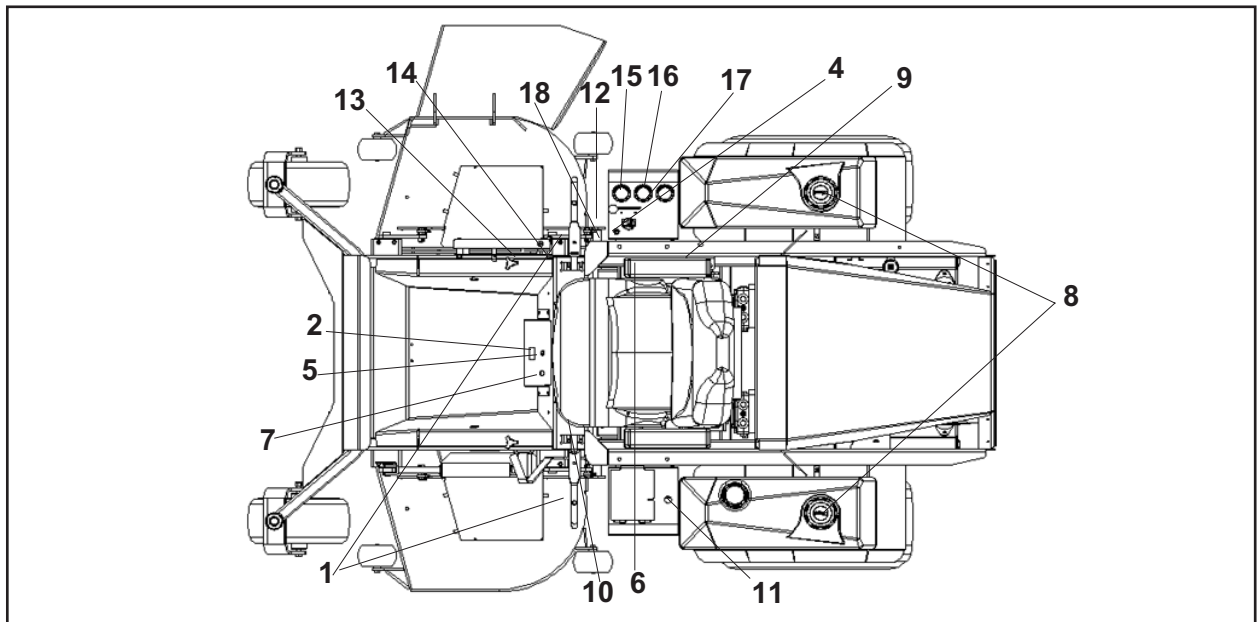

Locations of the controls

Control Locations

	Page		Page
1. Motion control, levers	20	10. Seat adjustment lever	19
2. Hour meter	18	11. 12V DC adapter	
3. Parking brake	19	12. Throttle	18
4. Control for mower deck	19	13. Cutting height adjuster	25
5. Ignition	18	14. Manual deck lift	23
6. Relays	24	15. Water temperature gauge	18
7. Glow plug lamp	26	16. Ammeter gauge	18
8. Fuel tank caps	22	17. Oil pressure gauge	18
9. Fuel shut-off	22	18. Hydraulic deck lift switch	21

CONTROLS

Gauges

Water temperature gauge- indicates coolant temperature and warns of overheat situation.

Ammeter - indicates amount of electrical flow at the battery. Under normal operating conditions the needle will be slightly on the plus (+) side of the gauge, showing that current is being supplied to the battery. At idle speed, the indicator may be at zero or on the negative (-) side. A continuous negative reading at normal operating speed indicates a malfunction in the charging system that should be checked immediately.

Oil pressure meter - tells what the pressure is in the oil system and warns if pressure is too low for operation.

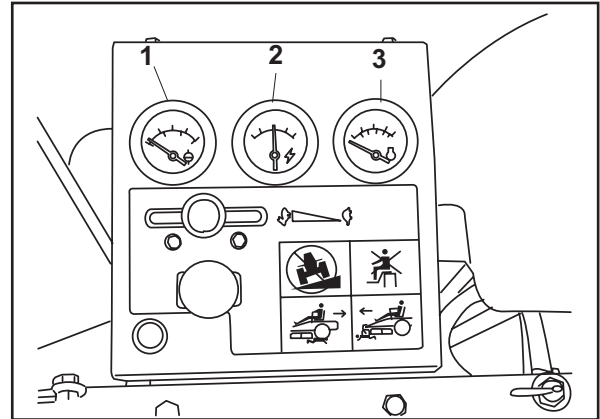

Gauges

BAM-2

1. Water temperature
2. Ammeter
3. Oil pressure

Throttle Control

The throttle control regulates the engine speed.

In order to increase or decrease the engine speed, the control is moved forward or backward respectively.

Avoid idling the engine for long periods.

Use full throttle when mowing.

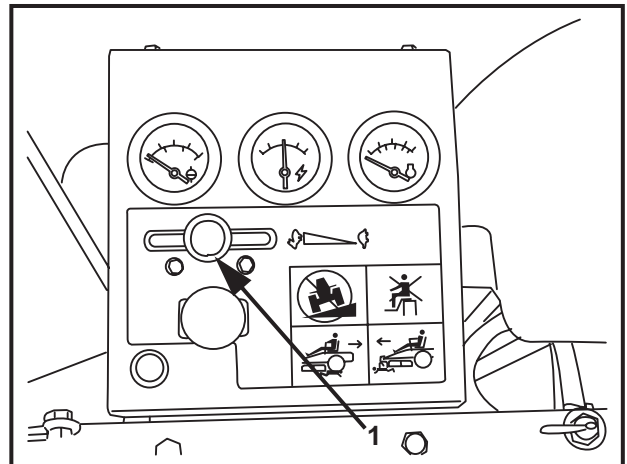

Throttle control

BAM-2

1. Throttle control

Ignition

The ignition key is placed in the front console and is used to start the machine.

IMPORTANT INFORMATION

Wait till the glow plug light goes out before turning the engine over. To prolong starter life use short starting cycles, DO NOT exceed 30 s/min.

Hour Meter

The hour meter displays the total operating time and reminds of service intervals.

It will flash CHG OIL (Change Oil) at 50 hour intervals. The flash duration is one hour before and one hour after the interval. The CHG OIL icon will come on and shut off automatically. The hour meter can not be manually reset.

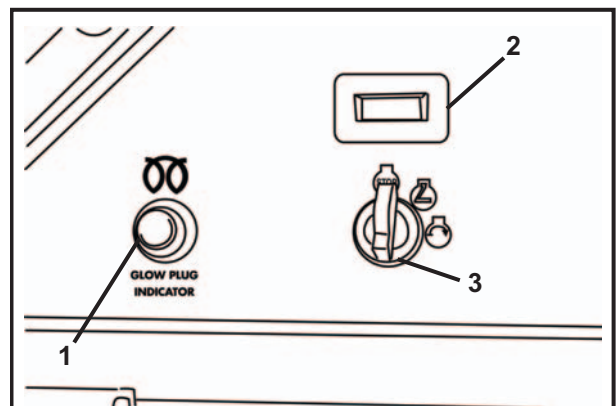

Console

BAM-3

1. Hour meter
2. Glow plug light
3. Ignition

CONTROLS

Engaging the Mower Deck

In order to engage the mower deck, pull the knob out; the mower deck is disengaged when the knob is depressed.

Deck should be engaged at mid throttle and disengaged at idle speed to prolong clutch life.

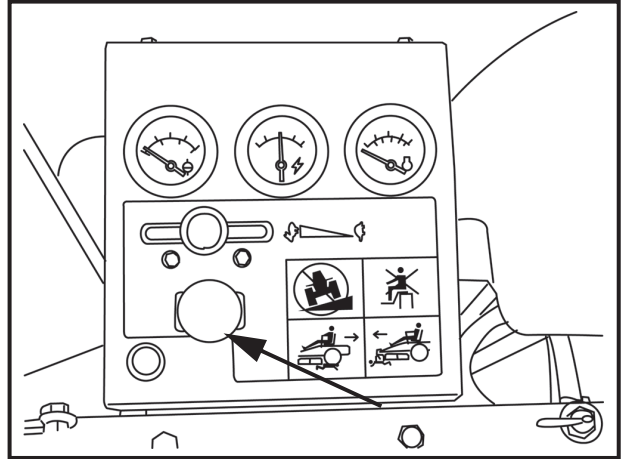

Engaging the mower deck

BAM-2

Parking Brake

The parking brake is found on the left of the machine. Pull the lever back to activate the brake and push forward to release it.

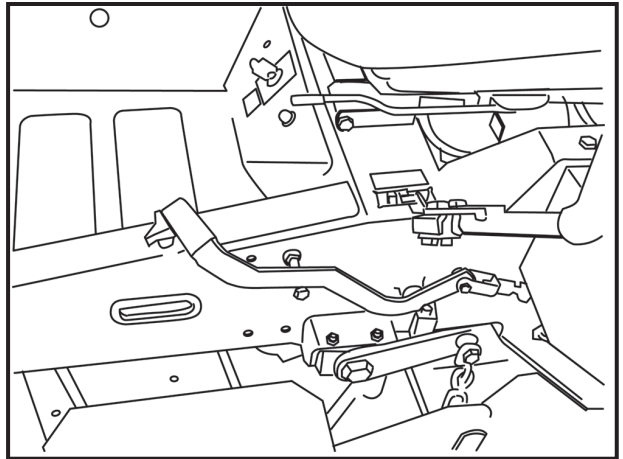

Parking brake not activated

BAM-4

Seat Adjustment

Located on the left side of the seat is the seat adjustment lever. Pull outward to slide the seat either forward or backward.

Suspension resistance (weight) can be adjusted at the front of the seat.

Backrest tilt and lumbar support can also be adjusted using dials on the sides of the seat.

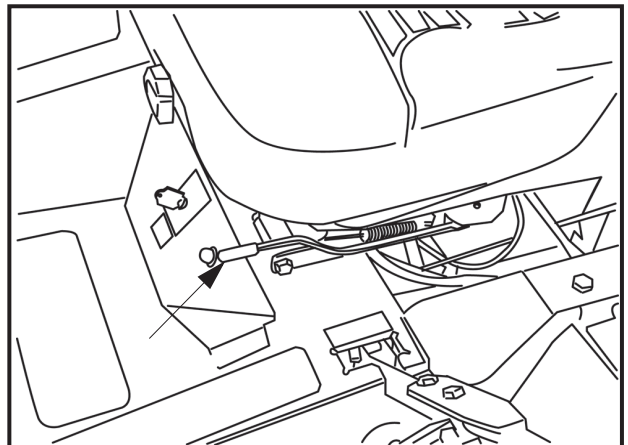

Seat Adjustment Lever and suspension adjustment

BAM-5

CONTROLS

Motion Control Levers

The machine's speed and direction are continuously variable using the two motion control levers. The motion control levers can be moved forward or backward from a neutral position. Furthermore, there is a neutral position, which is locked if the motion control levers are moved outward into the neutral slots.

When both controls are in the neutral position (N), the machine stands still.

The motion control levers on each side of the mower control the direction of movement. The left lever controls the flow of oil from the left hydro pump to the left wheel motor. The right lever controls the flow of oil from the right hydro pump to the right wheel motor.

NOTE: To begin motion, the operator must be in the seat and the parking brake disengaged before the motion control levers can be moved from the neutral slots or the engine will shut down.

By moving the levers an equal amount forward or back the machine will move in a straight line in that direction.

Movement of either lever forward will cause the right or left wheel to rotate in a forward direction. To stop movement pull both levers into the neutral position.

To turn right while moving in a forward direction pull the right lever back toward the neutral position, this will slow the rotation of the right wheel and cause the machine to turn in that direction.

To turn left while moving in a forward direction pull the left lever back towards the neutral position, this will slow the rotation of the left wheel and cause the machine to turn in that direction.

To zero turn pull one lever back beyond neutral while holding the other slightly ahead of neutral.

NOTE: The direction of the zero turn will be determined by which lever is pulled back beyond neutral. Thus left lever back, left zero turn and opposite for right zero turn. **Use extra care when using this maneuver the machine can spin very rapidly if one lever is positioned too far ahead of the other.**

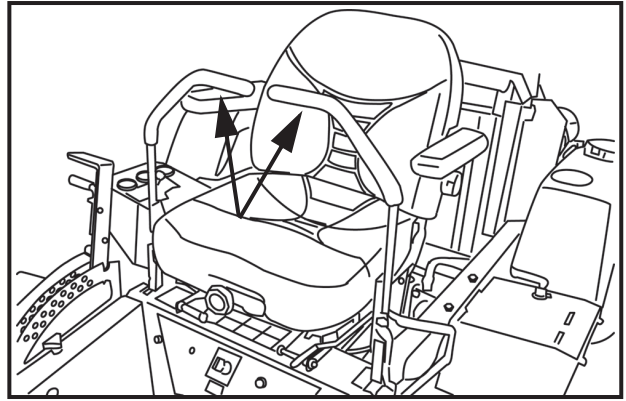

Motion Control Levers

BAM-6

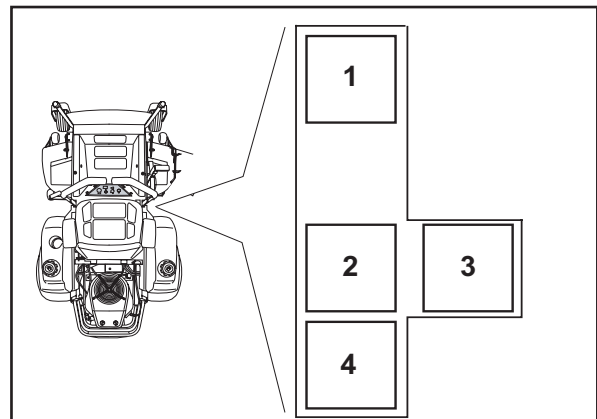

8011-791

- 1 Forward
- 2 Neutral
- 3 Neutral slot, Neutral lock
- 4 Reverse

Motion control lever pattern (right side)



WARNING!

The machine can turn very rapidly if one steering control is moved much further forward than the other.

CONTROLS

If the steering controls are in uneven positions when standing still, they can be adjusted using the adjustment screws, not the link system, for the controls

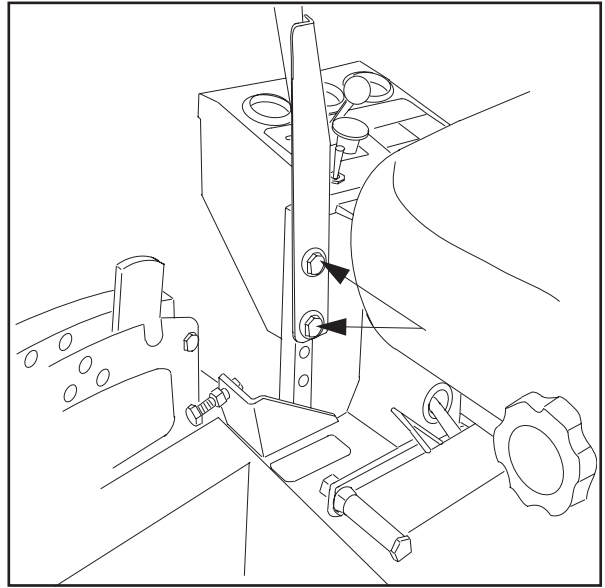

Adjusting screws

BAM-7

Hydraulic Lift Switch

Used to raise and lower the mower deck hydraulically. Only used on units with power deck lifts. Push switch forward to lower the deck and pull backward to raise the deck.

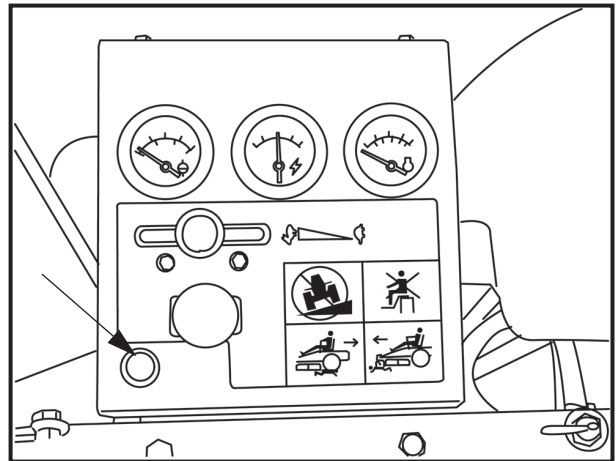

Hydraulic lift switch

BAM-2

CONTROLS

Refueling

The machine has two fuel tanks, one on each side just behind the seat. The tanks hold 11.4 gallons, 5.7 gallons each.

The engine is run on clean, fresh, diesel fuel with a minimum of 40 cetane.



WARNING!
Diesel fuel is highly flammable. Observe caution and fill the tank outdoors (see the safety rules).

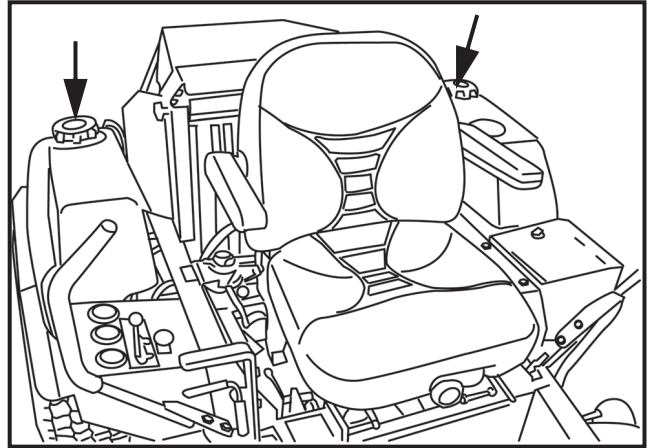

Fuel Tanks

BAM-8

Fuel Shut-Off

The fuel shut-off is placed to the right side of the seat. The shut-off has three positions; right tank, left tank and off position.

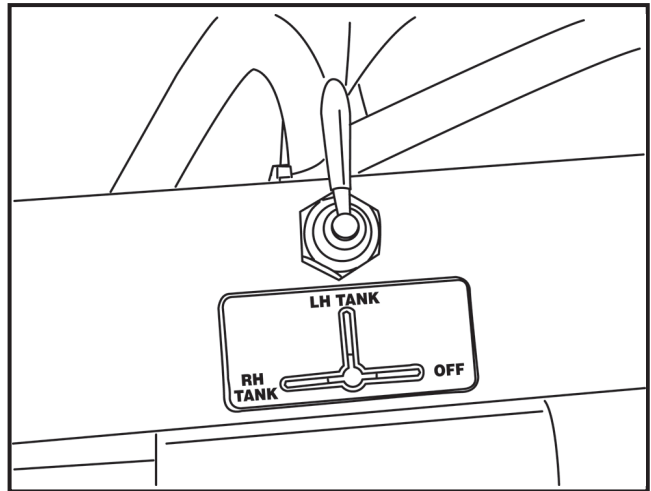

Fuel Shut-Off

BAM-9

Fuses

The fuses are located in a fuse block to the right of the battery. They are flat pin fuses of the same type used in automobiles.

There are five fuses.

Fuse ratings and functions moving from the top:

- 20A - accessory jack
- 7.5A - sub system
- 10A - PTO/clutch
- 30A - hydraulic deck lift
- 50A - main system fuse (in line)

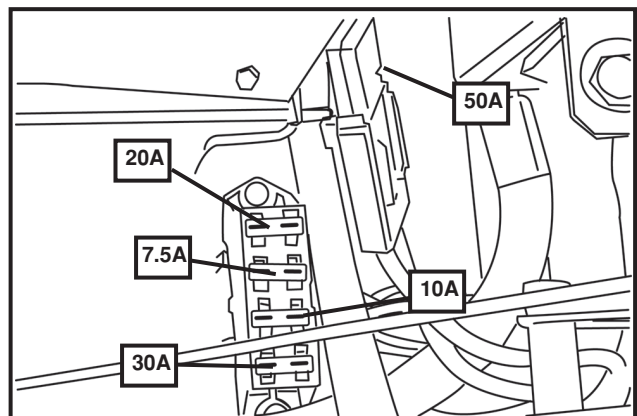

Fuses

BAM-10

CONTROLS

Manual Lifting Lever with Foot Assist for the Mower Deck

The lifting lever is used to place the mower deck in the transport position or one of the 17 different cutting height positions.

The cutting height is set by placing a pin in the hole for the desired cutting height and the pin is then locked on the inside (hidden in the illustration) with the supplied cotter pin.

1. Pull the lever backward while pushing on the foot pedal, lifting the deck to the locked position. The deck is then raised.
2. Depress the lock handle, counter hold, and move the lifting lever forward toward the pin to engage the set cutting height. The deck is then lowered.
3. The lifting lever can also be used to temporarily adjust the cutting height, such as when passing a minor bump in the lawn.

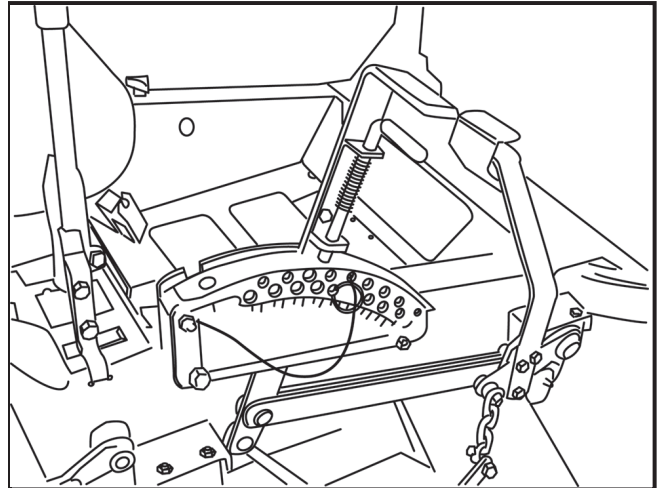

The mower deck's lifting lever and foot pedal

IMPORTANT INFORMATION

In order to obtain an even cutting height it is important that the air pressure in all four tires is the same (15 psi, 103.4 kPa).

Hydraulic Lift for the Mower Deck

1. Place pin in the appropriate hole for desired cutting height, secure with cotter pin.
2. Push switch forward on the console to lower deck to the set cutting height.
3. Pull backwards on the switch on the console to raise the deck for transport.

IMPORTANT INFORMATION

Pin must be locked into a hole for transport or mowing.

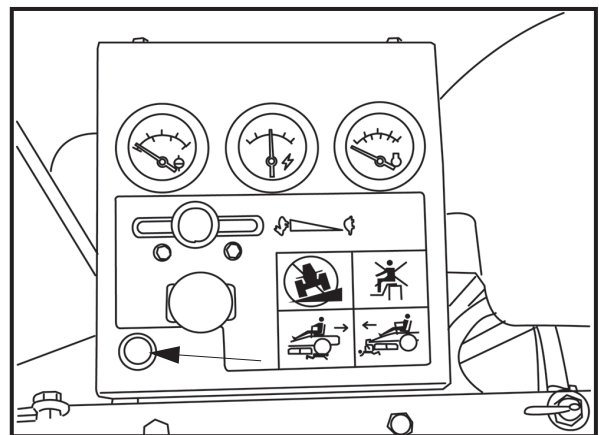

Hydraulic switch

CONTROLS

Relays

The relays and glow plug timer are located in a holder to the right side of the seat.

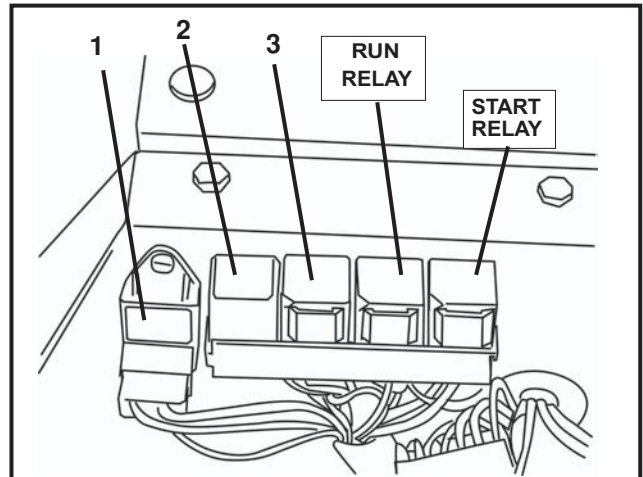

BAM-12A

Relays

1. Glow plug timer
2. Glow plug relay
3. Run relay
4. Start relay
5. Seat relay

Tracking

The tracking knob is located in front of the left control lever. Rotating this knob allows fine tuning adjustments so that the machine tracks straight with the drive levers in the full forward position. Rotate the knob clockwise (as viewed from the operating position) to increase the speed or counterclockwise to decrease the speed on the left control lever. Example: If control levers are full forward and the unit turns to the right, turn the tracking knob counterclockwise to decrease the speed on the left control lever.

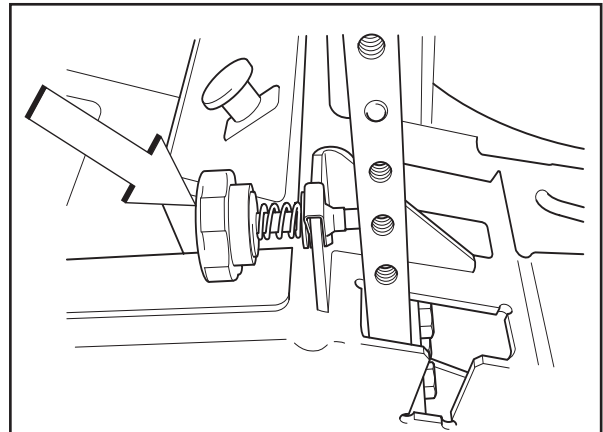

8011-442

Tracking knob

Accessories

For mulching, there is a Mulch Kit attachment available. This is mounted underneath the mower deck and comprised of baffles and mulch blades.

ROPS (Roll Over Protection System) is also available for the unit.

A baffle kit is available for the TRD61B - 61" and TRD72B - 72" cutting decks.

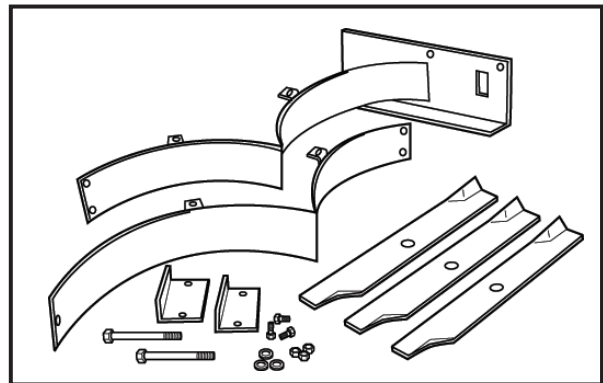

8011-566

Mulch kit attachment

OPERATION

Operation

Read "Safety Instructions" section and following pages, if you are unfamiliar with the machine.

Training

Zero turn mowers are far more maneuverable than typical riding mowers due to their unique steering capabilities.

We recommend that this section be reviewed in its entirety prior to attempting to move the mower under its own power. Additionally, we suggest when first operating mower, use a reduced throttle speed and reduced ground speed by NOT moving control levers to the furthest forward or reverse positions during initial operation, or until operator becomes comfortable with controls. We also suggest first time users, or new users to ZeroTurn mowers to become familiar with the mowers movement on a hard surface, such as concrete or blacktop PRIOR to attempting to operate on turf. Until operator becomes comfortable with mower controls and zero turning capability, they may damage turf due to over aggressive maneuvers.

To move forward and backward

The direction and speed of the mowers movements is effected by the movement of the control lever(s) on each side of mower. The left control lever controls the left wheel motor. The right control lever controls the right wheel motor.

IMPORTANT INFORMATION

When control levers are in the reverse position they return to neutral when released. This may cause the mower to suddenly stop.

First time users should push mower (see "Moving by Hand" in the "Operation" section) to an open, flat area, without other people or vehicles/obstacles near by. In order to move unit under its own power, the operator must be in the seat, start engine (see "Before Starting in the "Operation" section), adjust engine speed to idle, disengage park brake, do not engage blades at this time, rotate control levers inward. As long as the control levers have not been moved forward or backwards, mower will not move. Slowly move both control levers forward slightly, this will allow mower to start moving forward in a straight line. Pull back on control levers to the neutral position and mower should stop moving. Pull back slightly on control levers, this will allow mower to start moving backwards. Push forward on control levers to the neutral position and mower should stop moving.

To turn to the right

While moving in a forward direction, pull the right lever back towards the neutral position while maintaining the position of the left lever, this will slow the rotation of the right wheel and cause the machine to turn in that direction.

To turn to the left

While moving in a forward direction pull the left lever back towards the neutral position while maintaining the position of the right lever, this will slow the rotation of the left wheel and cause the machine to turn in that direction.

To zero turn

While moving in a forward direction, first pull both control levers back until the mower stops or slows dramatically. Then by alternating one lever slightly to the forward position and the other in the reverse position.

OPERATION

Before Starting

- Read the sections Safety Instructions and Controls before starting the machine.
- Perform the daily maintenance before starting (see Maintenance Schedule in the Maintenance section).
- Check that there is sufficient fuel in the fuel tanks.
- Adjust the seat to the desired position.

The following conditions must be fulfilled before the engine can be started:

- the driver must be seated on the seat,
- the blade switch for engaging the mower blades must be depressed,
- the parking brake must be on,
- both steering controls must be in the locked (outer) neutral position.

Starting the Engine

1. Sit on the seat.
2. Raise the mower deck by pulling the lifting lever backward to the locked position (transport position).
3. Activate the parking brake.

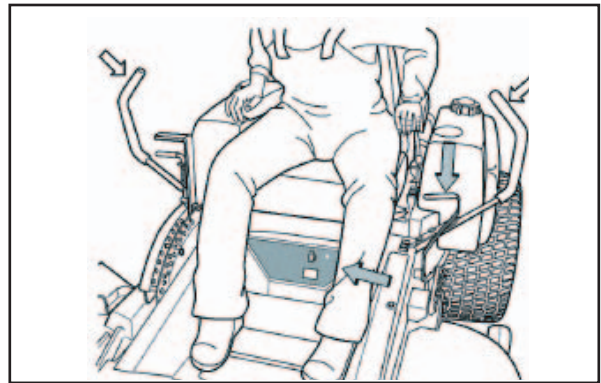

BAM-10

Start conditions

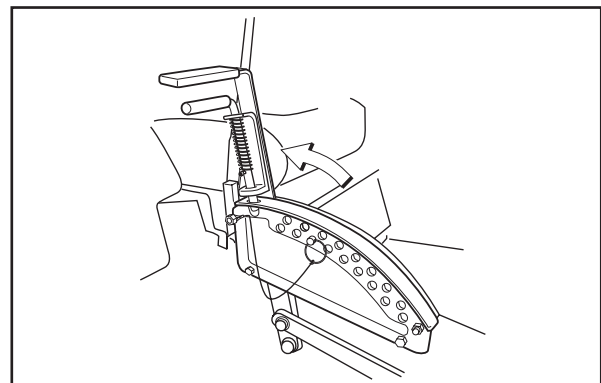

8011-552

Raise the mower deck

OPERATION

4. Disengage the mower blades by depressing the blade switch.

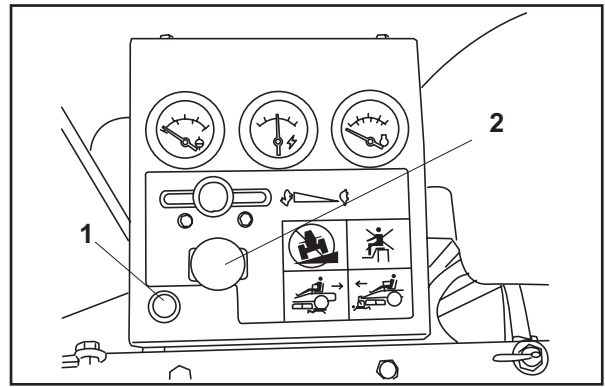

1. Deck lift switch
2. Mower deck knob

BAM-2

5. Move the steering controls outward to the locked (outer) neutral position.

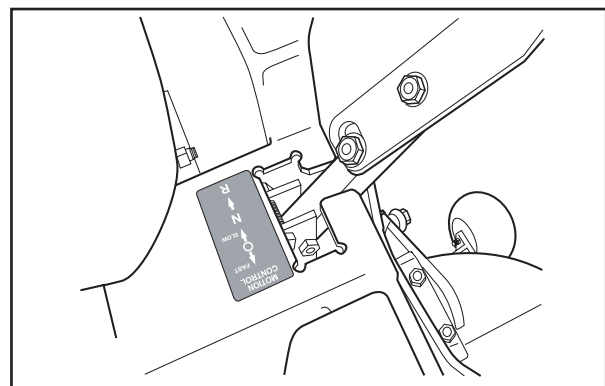

8011-526

Steering controls in the outward, locked neutral position

6. Move the throttle to the middle position.

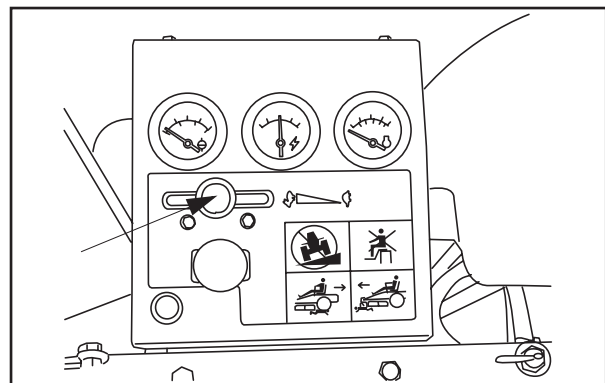

BAM-2

Set the throttle

OPERATION

7. Open the fuel valve for the selected fuel tank.

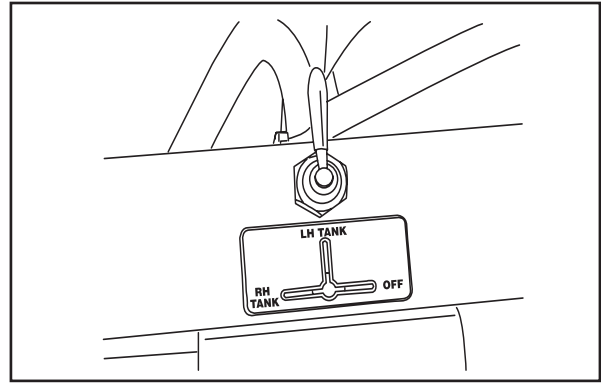

BAM-9

Open the fuel valve

8. Press in and turn the ignition key to the start position.

IMPORTANT INFORMATION

Wait till the glow plug light goes out or damage could result to the engine

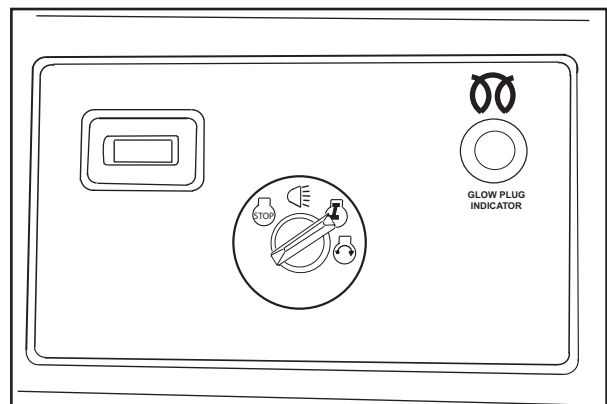

CONSOLE2

Start position

9. When the engine starts, immediately release the ignition key back to the run position.

IMPORTANT INFORMATION

To prolong starter life, use short starting cycles, not to exceed 30 secs./min. Extended cranking can damage starter motor.

OPERATION

10. Set the desired engine speed with the throttle.
Allow the engine to run at a moderate speed, "half throttle", for 3-5 minutes before loading it too heavily.
USE FULL THROTTLE WHEN MOWING.



WARNING!

Engine exhaust and certain vehicle components contain or emit chemicals considered to cause cancer, birth defects, or other reproductive system damage. The engine exhaust contains carbon monoxide, which is a odorless, colorless, poisonous gas. Do not use the machine in enclosed spaces.

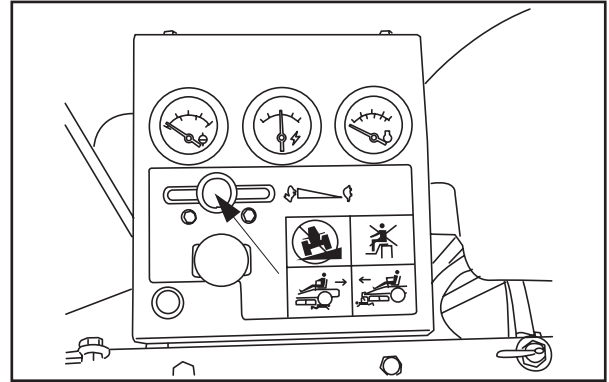

BAM-2

Set the engine speed

To start an engine with a weak battery



WARNING!

Lead-acid batteries generate explosive gases. Keep sparks, flame and smoking materials away from batteries. Always wear eye protection when around batteries.

If your battery is too weak to start the engine, it should be recharged. (See "Battery" in the "Maintenance" section).

If "jumper cables" are used for emergency starting, follow this procedure:

IMPORTANT INFORMATION

Your mower is equipped with a 12-volt negative grounded system. The other vehicle must also be a 12-volt negative grounded system. Do not use your mower battery to start other vehicles.

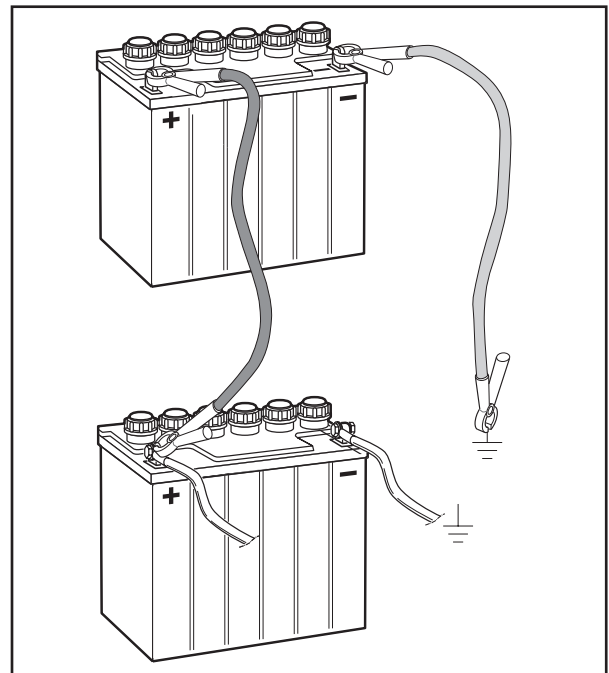

8011-642

Jumper cables connection

OPERATION

To attach jumper cables

- Connect each end of the RED cable to the POSITIVE (+) terminal on each battery, taking care not to short against chassis.
- Connect one end of the BLACK cable to the NEGATIVE (-) terminal of the fully charged battery.
- Connect the other end of the BLACK cable to a good CHASSIS GROUND on the mower with the discharged battery, away from the fuel tank and battery.

To remove cables, reverse order

- Remove BLACK cable first from chassis and then from the fully charged battery.
- Remove RED cable last from both batteries.

Running

1. Release the parking brake by moving the lever forward.

Your mower is equipped with an operator presence system. When the engine is running, any attempt by the operator to leave the seat without first setting the park brake will shut off the engine.

2. Move the steering controls to the neutral position (N).

3. Select the cutting height by placing the peg in one of the holes. Lock the peg on the inside with the pin.
4. Press in the stop handle, counter hold, and carefully move the lifting lever forward from the transport position toward the peg.

IMPORTANT INFORMATION

The mower deck's anti-scalp rollers should be evenly adjusted. See Maintenance section.

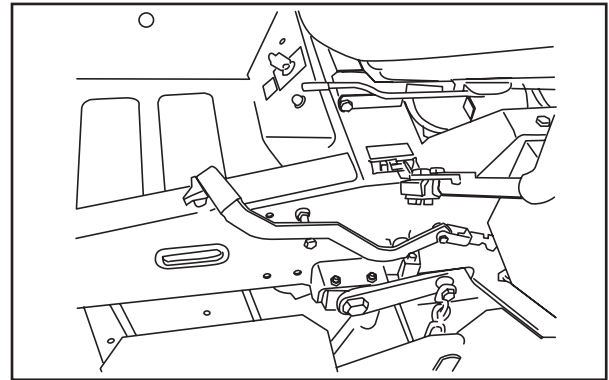

BAM-4

Released parking brake

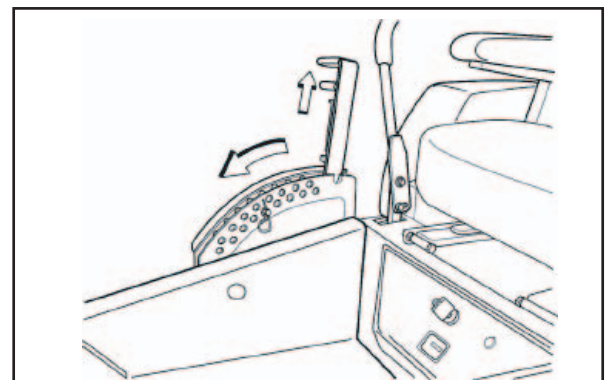

CUTTING HEIGHT

Cutting height selection

OPERATION

5. On power units push the hydraulic lift switch forward to lower the deck to the selected pin position.



WARNING!

Make sure that no one is near the machine when engaging the blade switch.

6. Engage the mower deck by pulling out the blade switch.
7. Move the throttle control to full throttle.
8. The machine's speed and direction are continuously variable using the two steering controls. When both controls are in the neutral position, the machine stands still.

By moving both controls an equal amount forward or backward, the machine moves in a straight line forward or backward respectively.

In order, for example, to turn right while moving forward, move the right control towards the neutral position. The rotation of the right wheel is reduced and the machine turns to the right.

Turning on the spot can be achieved by moving one control backward (behind the neutral position) and carefully moving the other steering control forward from its neutral position.

NOTE: The direction of the zero turn will be determined by which lever is pulled back beyond neutral. Thus left lever back, left zero turn and opposite for right zero turn. **Use extra care when using this maneuver the machine can spin very rapidly if one lever is positioned too far ahead of the other.**

NOTE: To begin motion, the operator must be in the seat and the parking brake disengaged before the motion control levers can be moved from the neutral slots or the engine will kill.

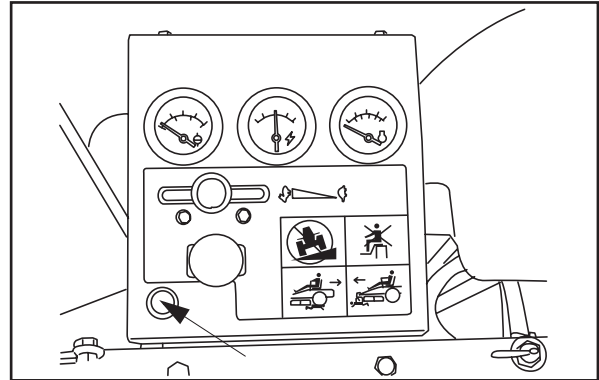

BAM-2

Hydraulic switch

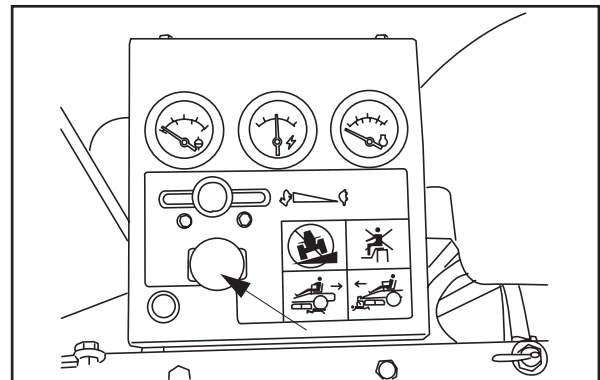

BAM-2

Engaging the mower deck

OPERATION

Operating on hills

Read the Safety Instructions "Driving on Slopes" in the "Safety Instructions" section.



WARNING!

Do not drive up or down hills with slopes greater than 10 degrees. And do not drive across any slopes.

- The slowest speed possible should be used before starting up or down hills.
- Avoid stopping or changing speed on hills.
- If stopping is absolutely necessary, pull drive levers into the neutral position and push to the outside of the unit and engage the park brake.

IMPORTANT INFORMATION

Control levers return to neutral when released. This may cause the mower to suddenly stop.

- To restart movement, release the park brake.
- Pull the control levers back to the center of the mower and press forward to regain forward motion.
- Make all turns slowly.

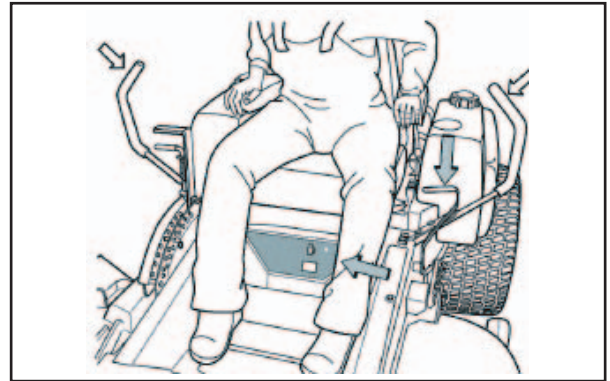

BAM-10

Stopping conditions

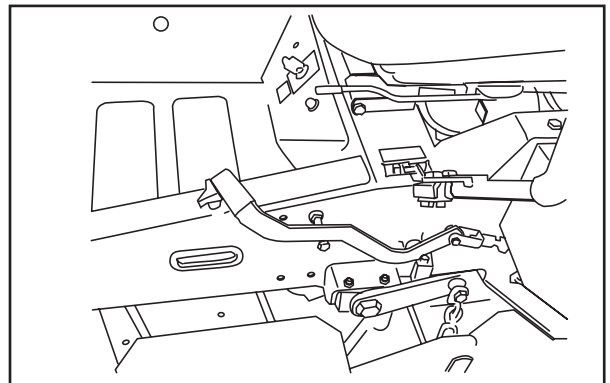

BAM-4

Released parking brake

OPERATION

Mowing Tips

- Observe and flag rocks and other fixed objects to avoid collisions.
- Begin with a high cutting height and reduce it until the desired mowing result is attained.

The average lawn should be cut to 2 1/2" (64 mm) during the cool season and over 3" (76 mm) during the hot months. For healthier and better looking lawns, mow often after moderate growth.

For best cutting performance, grass over 6" (15 cm) in height should be mowed twice. Make the first cut relatively high; the second to the desired height.

- The mowing result will be best with a high engine speed (the blades rotate rapidly) and low speed (the rider moves slowly). If the grass is not too long and dense, the driving speed can be increased without negatively affecting the mowing result.
- The finest lawns are obtained by mowing often. The lawn becomes more even and the grass clippings more evenly distributed over the mown area. The total time taken is not increased as a higher operating speed can be used without poor mowing results.
- Avoid mowing wet lawns. The mowing result is poorer because the wheels sink into the soft lawn, clumps build, and the grass clippings fasten under the cowl.
- Hose the mower deck underside with water after each use. When cleaning, the mower deck shall be raised into the transport position. Make sure the mower is cooled and the engine is off.
- Use compressed air to clean top surface of the deck. Avoid flooding water on top surface.
- When the mulching kit is used, it is important that the mowing interval is frequent.

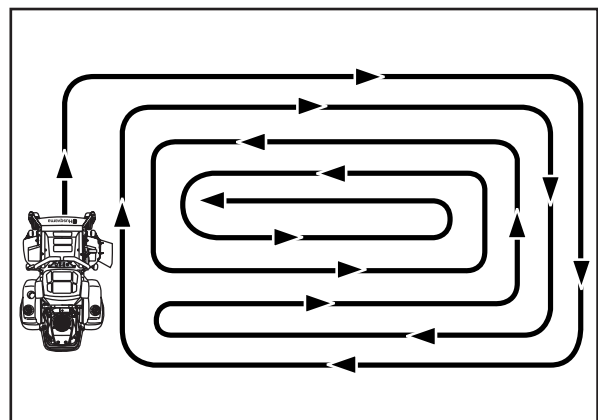
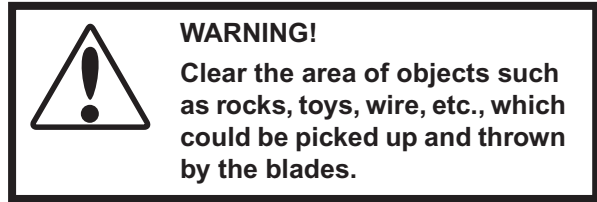

Mowing patterns

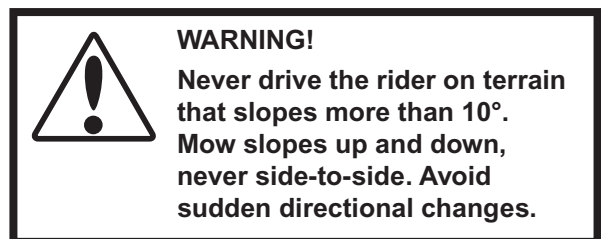

OPERATION

Stopping the Engine

Allow the engine to idle a minute in order to attain normal operating temperature before stopping it, if it has been worked hard. Avoid idling the engine for longer periods, as there is a risk of the spark plugs fouling.

1. Disengage the mower deck by depressing the blade switch.

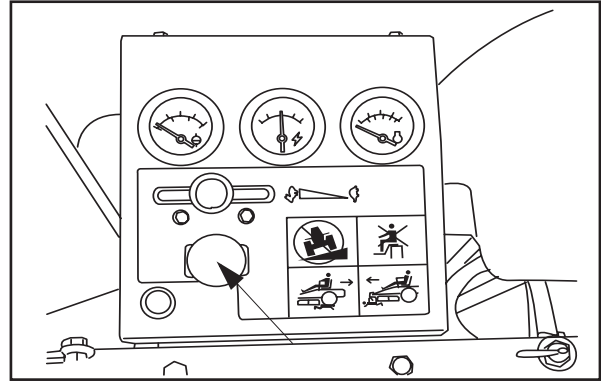

Disengage the mower deck

2. On manual decks raise the mower deck by pulling the lifting lever backward to the transport position.
3. On power decks raise the deck by pulling back the hydraulic switch on the console.
4. When the machine is standing still, activate the parking brake by pulling the lever backward.
5. Move the throttle to the minimum position (tortoise symbol). Turn the ignition key to the stop position. Never use choke to stop engine.
6. Move the steering controls outward.
7. Remove key. Always remove key when leaving the mower to prevent unauthorized use.

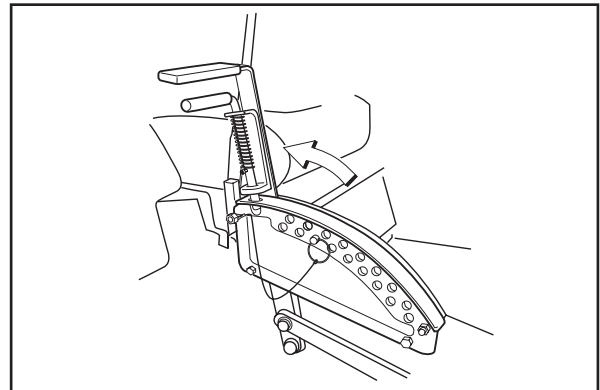

Raise the mower deck with the lifting lever

IMPORTANT INFORMATION

Leaving the ignition switch in any other position than "OFF" will cause the battery to be discharged and the hour meter to accumulate hours.

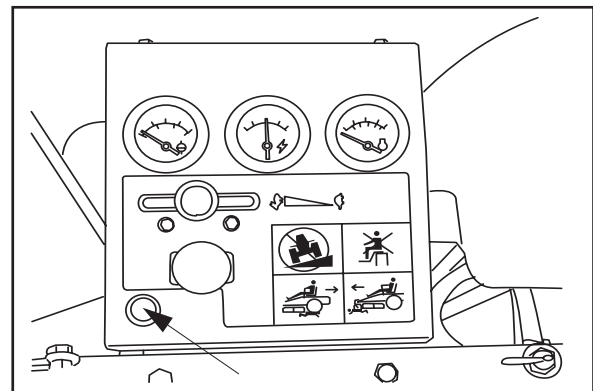

Hydraulic switch

OPERATION

Moving by Hand

In order for the machine to be moved with the engine turned off, the vent screws on both hydraulic pumps must be opened 1/4-1/2 turn.



WARNING!

No adjustments or maintenance to be carried out unless:

- the engine stopped,
- the ignition key has been removed,
- the parking brake is on.

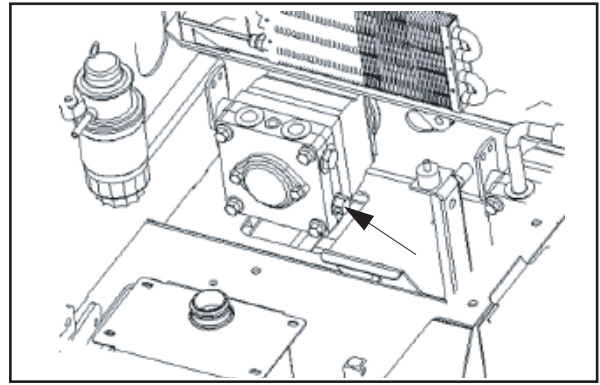

BAM-11

Vent screw on the hydraulic pump

MAINTENANCE

Maintenance

Maintenance Schedule

The following is a list of maintenance procedures that must be performed on the machine. For those points not described in this manual, visit an authorized service workshop. An annual service carried out by an authorized service workshop is recommended to maintain your machine in the best possible condition and to ensure safe operation.

Read "Maintenance" in the "Safety Instructions" section.

● = Described in this manual

○ = Not described in this manual

Maintenance	Page	Daily maintenance		Weekly maintenance	At least once each year	Maintenance interval in hours			
		Before	After			25	50	100	300
Check the parking brake	45	●							
Check the engine's oil level (every refueling)	53	●							
Check the hydraulic system's oil level	52	●							
Check the safety system	39	●							
Check for fuel and oil leakages	-	○							
Check rubber valve for sand trap	41		●						
Check/clean the engine's cooling air intake	40		●						
Check the mower deck	47		●						
Check hardware (screws, nuts, etc.)	54		●						
Clean under the mower deck	54		●						
Start the engine and blades, listen for unusual sounds	-		○						
Check for damage	-		○						
Thoroughly clean around the engine	-		○						
Thoroughly clean around the hydraulic system	-		○						
Clean around belts, belt pulleys, etc.	-		○						
Check the tire pressures	43					●			
Check battery	38					●			
Sharpen/Replace mower blades	47					●			
Check the fuel pump's air filter ²⁾	42					●			
Clean the engine's cooling air intake ²⁾	40				●	●			
Clean cyclon air filter dust cap	42				●	●			
Check/adjust the parking brake	-				○			○	
Inspect muffler/Spark arrester	-				○			○	

MAINTENANCE

Maintenance	Page	Daily maintenance		Weekly maintenance	At least once each year	Maintenance interval in hours			
		Before	After			25	50	100	300
Check/adjust throttle	40				●			●	
Check the condition of belts, belt pulleys, etc.	46				●			●	
Change the engine oil ¹⁾	53				●			●	
Replace the engine oil filter (every 200 hours)	58				●			●	
Clean/replace the spark plugs	38				●			●	
Replace the fuel filter	43				●			●	
Replace the air filter (main cartridge) ²⁾ (every 200 hours)	42				●			●	
Check the caster wheels (every 200 hours)	53							●	
Clean the cooling fins ²⁾	-				○			○	
Clean fins of oil cooler (Kohler)					●			●	
Check/adjust the mower deck	49				●				●
Change the hydraulic oil (every 300 hours)	-				○				○
Replace the hydraulic oil filter (every 300 hours)	-				○				○
Dismantle and inspect starter ⁴⁾ (every 500 h)									○
Check the engine valve clearance ⁴⁾	-				○				○
Perform the 300-hour service ⁴⁾	73				○				○
Lubricate according to Lubrication Schedule	51		●	●	●	●	●	●	●

¹⁾ First change after 8 hours. When operating with a heavy load or at high ambient temperatures, replace every 50 hours. ²⁾ In dusty conditions, cleaning and replacement are required more often. ³⁾ For daily use, the machine should be lubricated twice weekly. ⁴⁾ Performed by authorized service workshop.

● = Described in this manual

○ = Not described in this manual



WARNING!

No adjustments or maintenance to be carried out unless:

- The engine is stopped.
- The ignition key has been removed.
- The parking brake is on.

MAINTENANCE

Battery

Your mower is equipped with a maintenance free battery and does not need servicing. However, periodic charging of the battery with an automotive type battery charger will extend its life.

- Keep battery and terminals clean.
- Keep battery bolts tight.
- Recharge at 6-10 amperes for 1 hour.

To clean battery and terminals

Corrosion and dirt on the battery and terminals can cause the battery to “leak” power.

1. Lift seat and rotate forward.
2. Remove the red terminal guard.
3. Disconnect BLACK battery cable first, then the RED battery cable and remove the battery from the machine.
4. Rinse the battery with plain water and dry.
5. Clean terminals and battery cable ends with wire brush until shiny.
6. Coat terminals with grease or petroleum jelly
7. Reinstall battery.

Replacing battery

1. Lift seat and rotate forward.
2. Remove the red terminal guard.
3. Using two 1/2" wrenches disconnect BLACK battery cable then RED battery cable.
4. Remove the knobs and remove battery hold downs.
5. Carefully remove the battery from the mower.
6. Install new battery with terminals in the same position as the old battery.
7. Reinstall battery hold downs.
8. First connect RED battery cable to positive (+) battery terminal with hex bolt and hex nut.



Always use protective glasses when handling the battery.

IMPORTANT INFORMATION

Do not attempt to open or remove caps or covers. Adding or checking level of electrolyte is not necessary.

Always use two wrenches for the terminal screws.



WARNING!

Do not short battery terminals by allowing a wrench or any other object to contact both terminals at the same time. Before connecting battery, remove metal bracelets, wristwatch bands, rings, etc.

Positive terminal must be connected first to prevent sparks from accidental grounding.

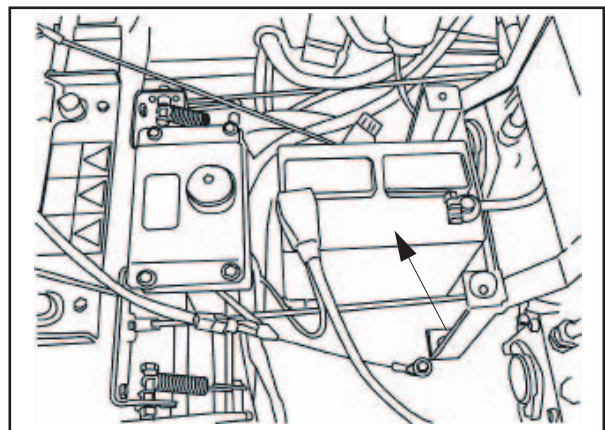

Battery installation

BAM-21

MAINTENANCE

9. Connect BLACK grounding cable to negative (-) battery terminal with remaining hex bolt and hex nut.
10. Fit the terminal guard.
11. Lower seat.

Checking the Safety System

The machine is equipped with a safety system that prevents starting or driving under the following conditions.

The engine can only be started when:

1. The mower deck is disengaged.
2. The steering controls are in the outer, locked neutral position.
3. The driver is sitting in the driver's seat.
4. The parking brake is on.

Make daily inspections to ensure that the safety system works by attempting to start the engine when one of the conditions is not met. Change the conditions and try again. If the machine starts when one of these conditions is not met, turn the machine off and repair the safety system before using the machine again.

Make sure the engine stops when the park brake is not engaged and the operator leaves the seated position.

Check that the engine stops if the mower blades are engaged and the driver temporarily stands up.

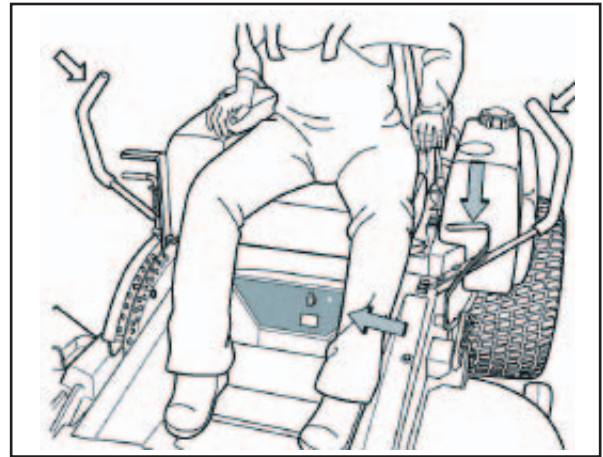

BAM-10

Conditions for starting

IMPORTANT INFORMATION

In order to be able to drive, the driver must sit in the seat and release the parking brake before the steering controls can be moved into the neutral position, otherwise the engine will stop.

MAINTENANCE

Checking the Engine's Cooling Air Intake

Check that the engine's cooling air intake is free from leaves, grass, and dirt.

If the cooling air intake is clogged, engine cooling deteriorates, which can lead to engine damage.

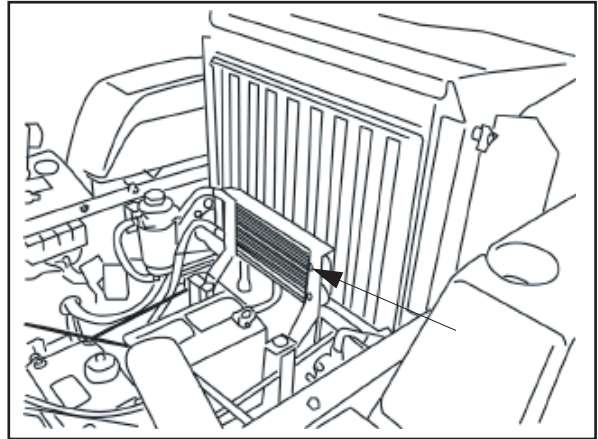

BAM-13

Check and clean the cooling air intake

Checking and Adjusting the Throttle Cable

Check that the engine responds to throttle increases and that a good engine speed is attained at full throttle.

If doubts arise, contact the service workshop.

If adjustments are necessary, they can be made as follows for the lower cable:

1. Loosen the clamping screw for the cable's outer casing and move the throttle to the full throttle position.
2. Check that the throttle cable is mounted in the correct hole in the lower lever, see illustration.
3. Push the throttle cable's outer casing as far to the left as possible and tighten the clamping screw.

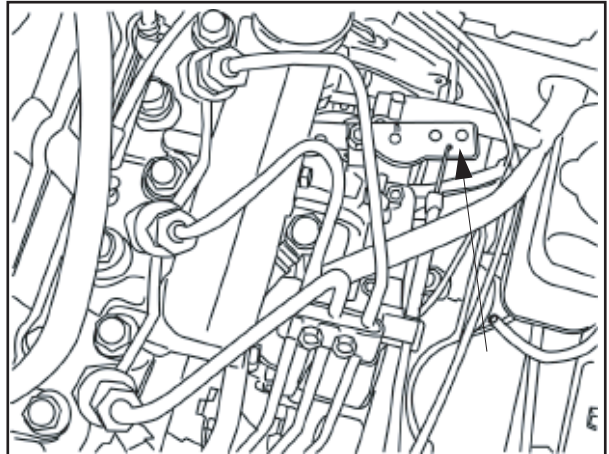

BAM-14

Adjusting the throttle cable

Clutch Service and Maintenance

The clutch has an adjustable air gap that should not require adjustment for the life of the machine. Refer to the manufacture's specifications sheet included with the mower.

MAINTENANCE

Replacing the Air Filter

If the engine seems weak or runs unevenly and the dust load indicator has turned red the air filter may be clogged. If run with a clogged air filter, disruption of operation can occur. For this reason, it is important to replace the air filter regularly (see the heading Maintenance Schedule for the proper service interval).



WARNING!

The engine and the exhaust system, become very hot during operation.

Risk for burns if touched.

Allow engine and exhaust system to cool at least two (2) minutes.

Cleaning/replacing the air filter is carried out as follows:

IMPORTANT INFORMATION

Do not use compressed air to clean the air filter.

Do not wash the paper filter.

Do not oil the paper filter. Do not tap filter to clean this could cause damage to the sealing.

Dust cap

Check the dust cap every day by pressing the rubber valve with two fingers to let out the dirt.

IMPORTANT INFORMATION

The end cover must be installed with the rubber valve pointing downwards, otherwise the rubber valve will not function.

Clean the dust cap by removing the end cover of the the air cleaner and clean inside.

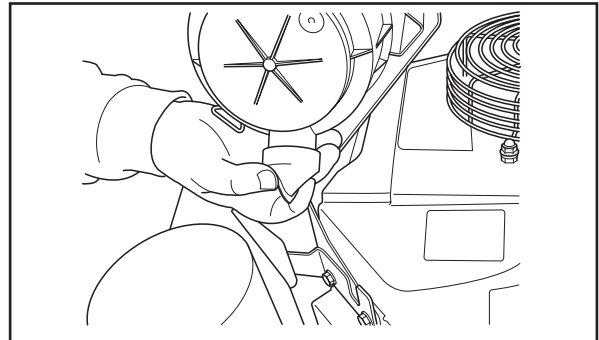

Pressing the rubber valve

8011-447

MAINTENANCE

Filter replacement

1. Unfasten the two plastic clamps on the sides of the air filter cover. Remove the air filter cover.
2. Remove the main filter (outer filter) by pulling it out by hand. Lightly brush or use mild air pressure to clean.
3. Only remove and replace safety element after the paper filter has been replaced 3 or 4 times.
4. Clean inside of the filter housing. Wipe dry only.
5. Install the inner filter with the open end first. Ensure that it enters its recess at the end of the housing and push it in to the end.
6. Install the main filter with the open end first. Ensure that it enters its recess at the end of the housing and push it in to the end.

IMPORTANT INFORMATION

The end cover must be installed with the rubber valve pointing downwards, otherwise the rubber valve will not function.

7. Replace the cover over the air filter housing. Fasten the two plastic clamps making sure the cover is snapped into position.
8. Turn the end cover with the rubber valve pointing downwards and install it.
9. Push top of dust load indicator to reset it.

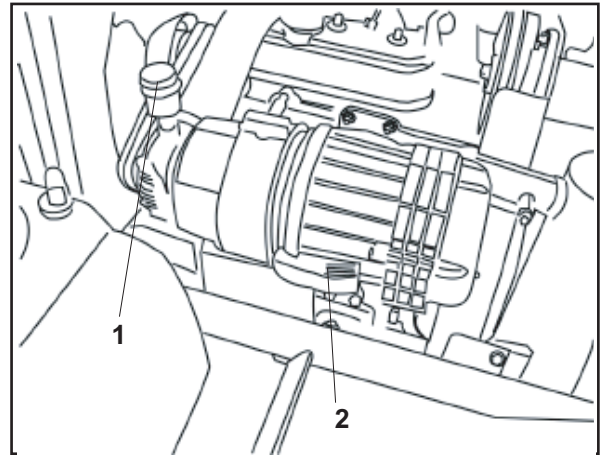

1. Dust Load Indicator
2. Clamp
Removing the air filter cover

BAM-15

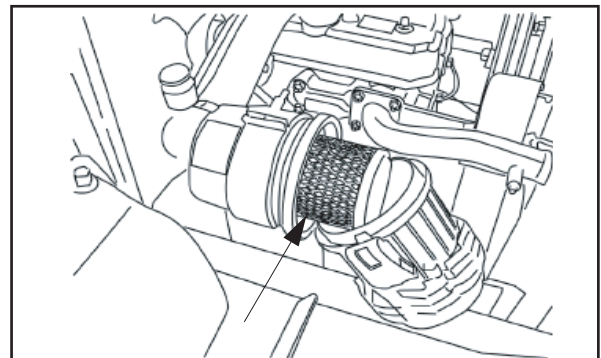

Paper filter

BAM-16

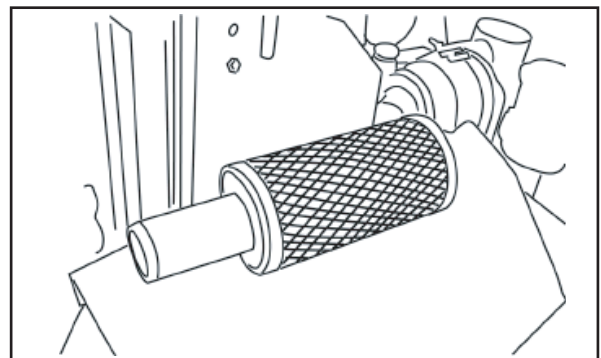

Safety element

BAM-17

MAINTENANCE

Replacing the Fuel Filter

The fuel filter is located with the priming pump.

Replace the fuel filter every 800 hours (once per season) or more regularly if it becomes clogged.

Replace the filter as follow:

Unscrew fuel filter from pump and replace.

Every 50 hours check for water in the fuel filter. Empty if necessary. Refer to the engine manual.

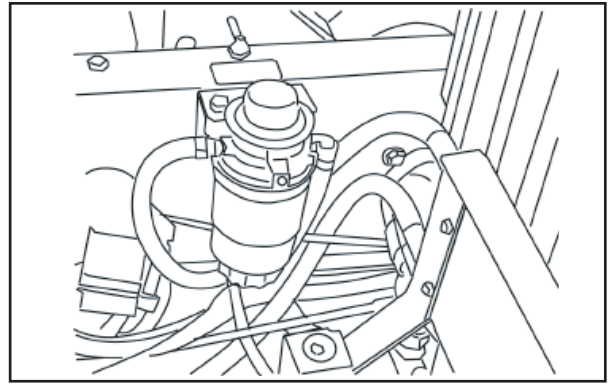

Fuel filter and fuel pump

Checking Tire Pressures

All four tires should have a pressure of 15 psi / 103 kPa / 1 bar.

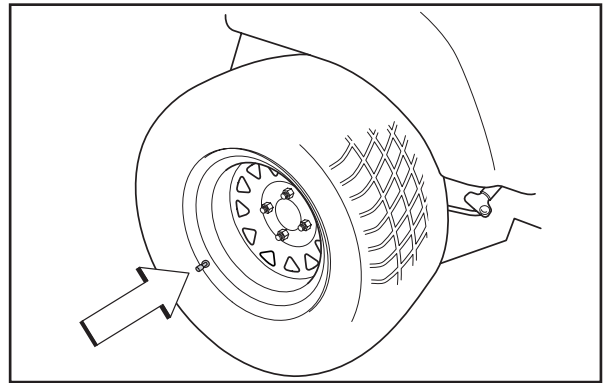

Tire pressures

Check and Filling Coolant System



WARNING!

ALWAYS make sure the engine is stopped and cool before removing radiator pressure cap. To prevent scalding by hot fluid, **NEVER** remove the radiator cap while engine is hot.

NOTE: Failure to follow the recommended procedure for filling the cooling system will cause engine overheating and possible engine failure.

ALWAYS check coolant level at the overflow reservoir. The correct level of coolant in the overflow tank does **NOT** assure the radiator is full.

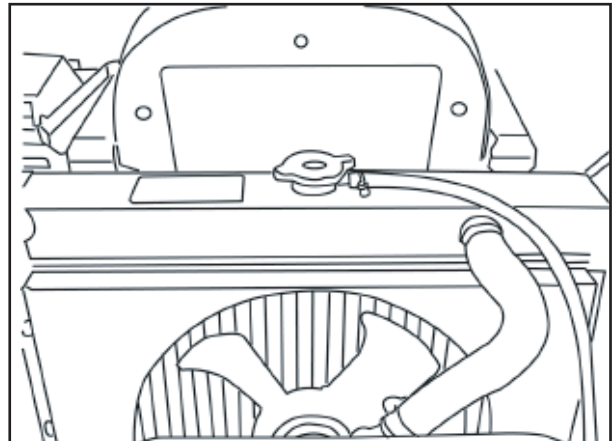

Radiator

MAINTENANCE

It is extremely important that when antifreeze is used, that it be mixed with water in a separate container before adding. **NEVER** add straight antifreeze to the radiator. Recommended mix is 50/50 lowtox (propylene glycol) phosphate-free antifreeze with tap water. **DO NOT** mix in ethylene glycol. Refer to engine operator's manual.

The radiator for this cooling system is provided with two drain valves; one at each end of the lower tank. When draining the system, it is necessary to open both these valves to drain the radiator completely.

Add coolant to the bottom of the fill cap again. Install radiator pressure cap. Add coolant to the proper line on the over flow tank between FULL and LOW.

When refilling the system, it is important that all trapped air be purged. The following procedure will help to insure this:

1. Make sure the engine is level. Fill the overflow reservoir up to the MAX mark with coolant mixture.
2. Slowly fill the radiator to the bottom of the filler neck with coolant mixture.
3. With radiator cap off, start the engine and let it warm up (no-load). Then, if necessary, add more coolant mixture to bring the level back up to the bottom of the filler neck.
4. Reinstall the radiator cap and run the engine a short time with the system sealed while watching the temperature gauge. If the temperature gauge goes past 230 degrees and does not drop back to approximately 190 degrees, indicating the thermostat has opened, allow the engine to cool down, check for leaks and repeat the procedure.

This is a sealed system. If it becomes necessary to add coolant mixture at a later date, check for leaks and if the overflow reservoir has not been drained completely, add coolant mixture to the reservoir only. This will help prevent air pockets in the radiator top tank and lessen the chance of introducing contaminants to the system.

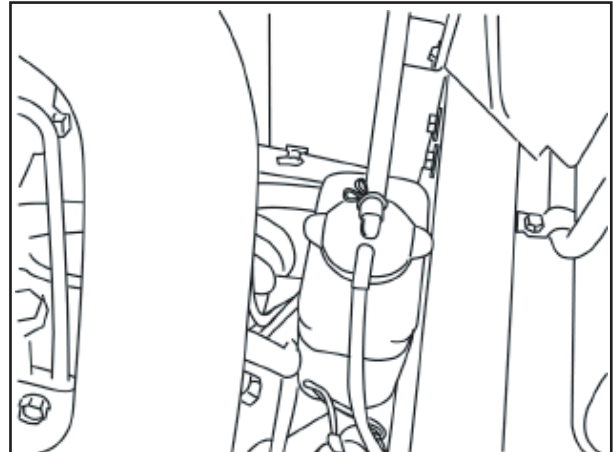

BAM-20

Overflow bottle

MAINTENANCE

Checking the Parking Brake

Visually check that no damage is found on the lever, links, or switch belonging to the parking brake. Perform a test drive and check that there is sufficient braking action.

To adjust the parking brake:

1. Set brake lever (D) fully forward against stop.

NOTE: Brake cross shaft **MUST** be properly lubricated and both cross shaft and over-center assemblies (F) **MUST** rotate freely.

2. Loosen jam nut (A) at rear of clevis (B) and remove clevis pin (C) both sides of mower.
3. Rotate over-center assembly (F) in correct direction (clockwise on left counter-clockwise on right) to pull brake actuating arm (E) forward until firm contact between brake shoes and drum can be felt. Hold in this position.
4. Rotate clevis until clevis pin can just be inserted thru clevis and brake lever with pin resting against rear of the hole in brake lever.
5. Remove clevis pin and rotate clevis two (2) full turns toward rear to allow correct clearance between brake shoes and drum.
6. Temporarily reinstall clevis pin (**do not** install cotter pin) to keep clevis from turning and tighten jam nut.
7. Remove pin and repeat above procedure on opposite side.
8. Reinstall clevis pins and secure with new cotter pins.
9. Set brake lever rearward to fully engaged position.
10. Adjust spring (G) to correct tension by turning rear jam nut until spring measures 1 1/8".

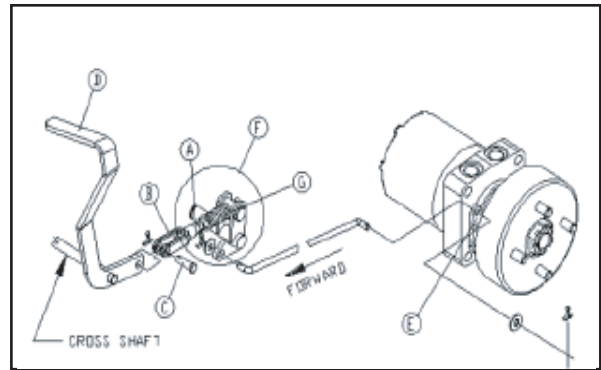

Park brake linkage

Parking brake linkage



WARNING!
Faulty adjustment can cause
an accident.

MAINTENANCE

Checking the V-belts

Deck belt

Check every 100 hours of operation. Check for severe cracking and large nicks.

NOTE: The belt will show some small cracks in normal operation.

To replace belt lower the deck to its lowest position. Remove the foot plate and belt shields.

Use a ratchet with a 9/16" socket on the spring idler bolt to relieve the tension on the belt. Slide the belt off of pulley and remove the belt.

Reverse the procedure for installation. See the decal on the top of deck for belt routing information.

After installation is complete check the belt for twists.

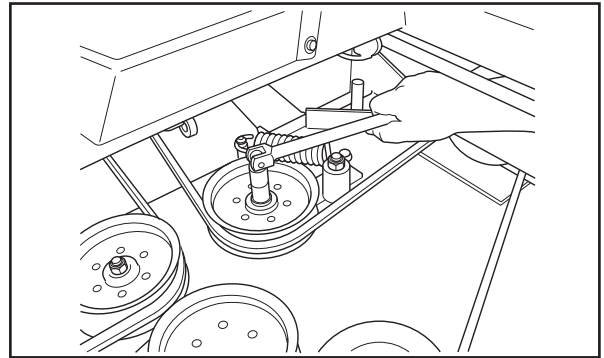

Slackening the belt tensioner

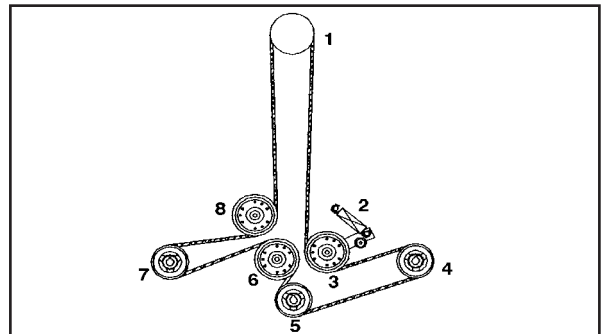

Belt routing, deck belt

Pump belt

Check belt every 100 hours for excessive wear.

To replace belt. Relieve tension on the deck belt and remove deck belt from clutch. See "Deck belt" on page 46. Loosen bolt on the clutch tie down and rotate out of the way.

Using a 1/2" drive ratchet inserted into the square hole in the pump idler arm relieve the tension on the pump belt and remove belt.

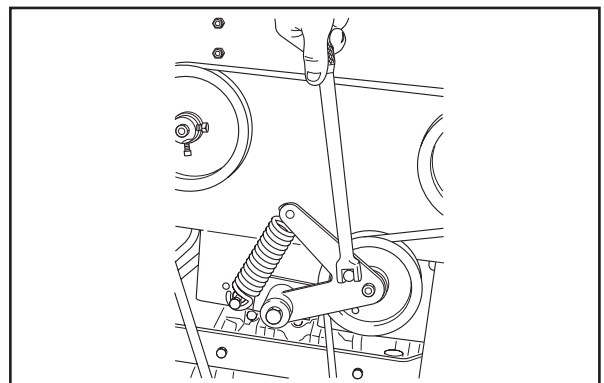

Slackening the belt tension

MAINTENANCE

To reinstall belt: Swing pump idler pulley toward engine to route belt around it. Then route belt around the pulley for left pump first.

Reinstall idler spring and use the ratchet to rotate idler so the belt may be installed all the way around the last pulley.

Checking the Blades

In order to attain the best mowing performance, it is important that the blades are well sharpened and not damaged.

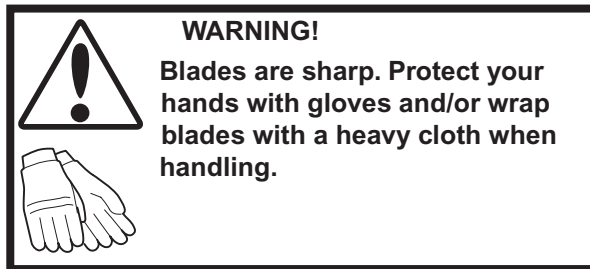

Bent or cracked blades or blades with large nicks should be replaced.

Check the blade mounts.

IMPORTANT INFORMATION

The sharpening of blades should be carried out by an authorized service workshop.

Damaged blades should be replaced when hitting obstacles that result in a breakdown. Let the service workshop decide whether the blade can be repaired/ground or must be discarded.

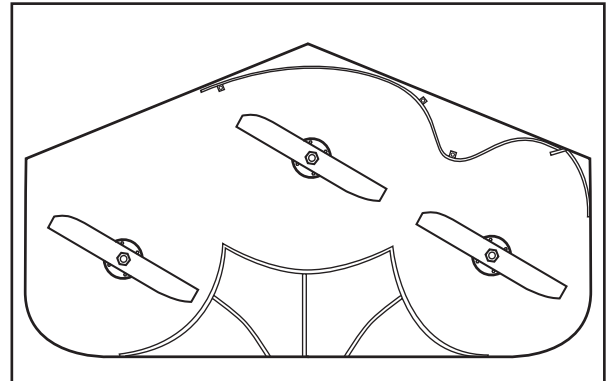

8011-604

Check the blades

MAINTENANCE

Blade replacement:

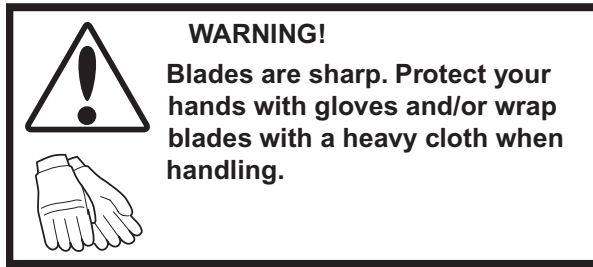

- Remove blade bolt by turning counterclockwise.
- Tunnel deck blades are sharpened on both sides and can be installed either way. Combi deck blades are not sharpened on both sides.
- Install and tighten blade bolt securely.
Tunnel Ram Deck - Torque blade bolt to 90 ft/lbs (122 Nm).
Combi Deck - Torque blade bolt to 57-61 ft/lbs (77-82 Nm).

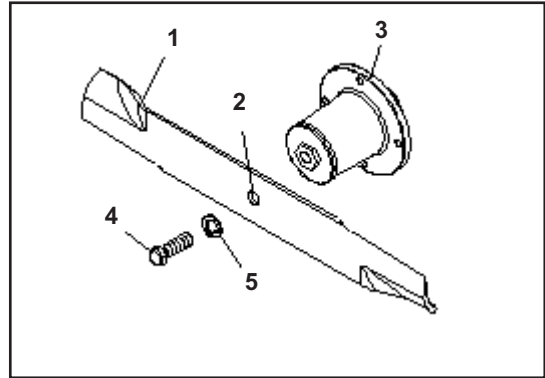

8011-671

1. Blade
2. Center hole
3. Cutter housing
4. Blade bolt (special)
5. Lockwasher

Blade attachment, principal

MAINTENANCE

Adjusting the Mower Deck



WARNING!

Before performing any service or adjustment checklist:

1. Engage the parking brake.
2. Place the blade-switch in the disengaged position.
3. Turn ignition switch to "OFF" position and remove the key.
4. Make sure the blades and all moving parts have completely stopped.
5. Disconnect the spark plug wire from all spark plugs and place the wire where it cannot come in contact with the plug.

Leveling

1. Position the mower on a level, preferably concrete, surface.
2. Check the pressure in all four tires. See "Technical Data" section.
3. Raise the mower on lengths of 2" x 4" placed edgewise under the cutting deck from front to rear (see diagram).
4. Lower the deck onto the 2" x 4"s. The rear of the deck is approximately 1/4" deeper than the front. This gives the deck a proper pitch front to back when lowered onto the 2" x 4" guides.
5. Set the cutting height to 4".
6. Adjust the four lower chain bolts so that they are centered in the oblong slots.
7. Move the lifting lever and check that all the chains are equally tensioned. If they are not, adjust the appropriate lower chain bolt in its slot.



WARNING!

Blades are sharp. Protect your hands with gloves and/or wrap blades with a heavy cloth when handling.

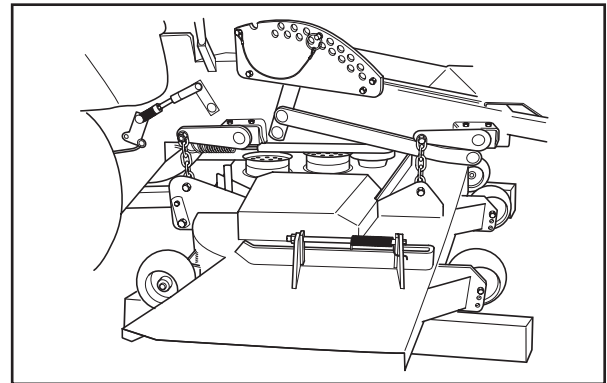

8011-601

Leveling the mower deck, hang chain version

Adjusting Cutting Height

1. Raise and secure the deck height lever to the transport position (Tunnel Ram Deck - 6"(150mm), Combi Deck - 5 3/4"(146mm).
2. Position blade tip so it is straight forward.
3. Measure from the cutting edge of the blades to a flat level surface. The distance should be (Tunnel Deck - 6" (150 mm), Combi Deck - 5 3/4"(146mm).
4. Drop and secure the lever at (for example) the 2" cutting height. Measure as above. The distance should be 2" (50 mm).

MAINTENANCE

To adjust anti-scalp rollers

Anti-scalp rollers are properly adjusted when they are just slightly off of the ground when the deck is at the desired cutting height in the operating position. Anti-scalp rollers then keep the deck in the proper position to help prevent scalping in most terrain conditions.

IMPORTANT INFORMATION

Adjust Anti-scalp rollers with the mower on a flat level surface.

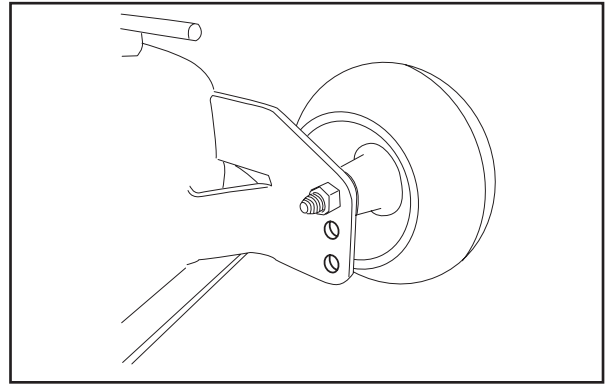

CZ-9

Anti-scalp roller

Tunnel Ram Deck -

The anti-scalp rollers can be set in three positions:

- Upper position 1.5" to 3"/38 to 76 mm grass.
- Middle position 3" to 4.5"/76 to 114 mm grass.
- Lower position 4.5" to 6"/114 to 152 mm grass.

Combi Deck -

- Upper position 1.5" to 3.0" (38 to 76mm) grass.
- Lower position 3.0" to 4.5" (76 to 114mm) grass.

The rollers should be approximately 1/4"/6.5 mm from ground. Do not adjust the rollers to support the deck.

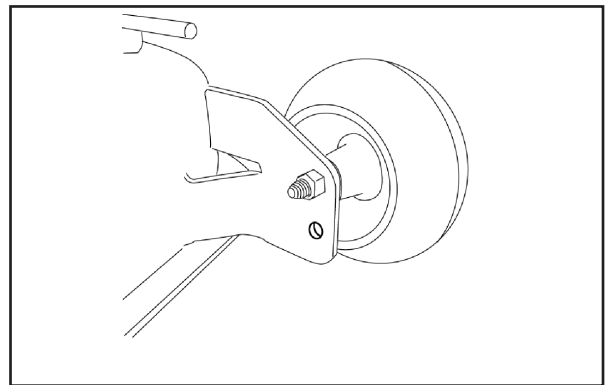

CZ-9

Anti-scalp roller - Combi Decks

IMPORTANT INFORMATION

The anti-scalp rollers must not be used for gauge wheels or the roller and deck may be damaged.

MAINTENANCE

Checking the Hydraulic System

Total System Capacity.....1.125 gal.

To check the hydraulic fluid level, locate the hydraulic reservoir under the seat. Remove cap and check level. Fill to 1/4" from top of tank



WARNING!

If a leak is suspected, use a piece of cardboard or wood, NOT your hands, to check for leaks.

Escaping hydraulic oil under pressure can have sufficient force to penetrate the skin, causing serious injury.

If injured by escaping fluid, see a doctor at once. Serious infection or reaction can develop if proper medical treatment is not administered immediately.

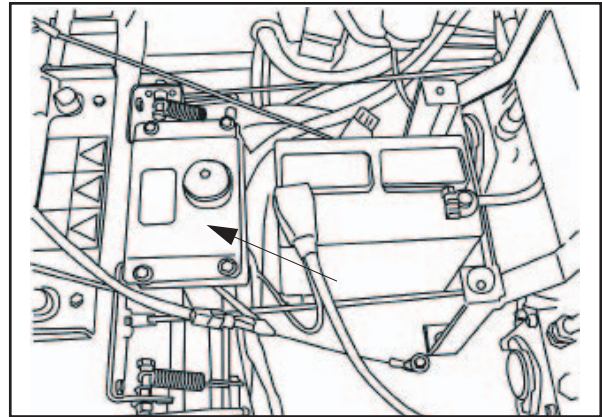

BAM-21

Hydraulic reservoir

MAINTENANCE

Motion Control Linkage Adjustment

This adjustment must be made with the rear wheels rotating. Raise the rear of the machine and block it up so the wheels are free to rotate

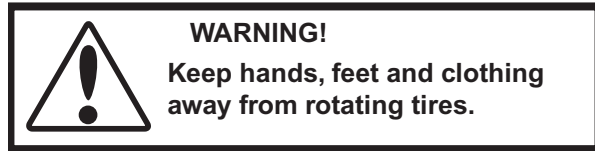

Place a 2 x 4 board between the foot plate and the center of the seat to engage the seat safety switch.

Loosen the nuts (A and B) directly behind each ball joint on linkages (C). See illustration.

Start the engine. The park brake must be engaged and the motion control levers in the neutral slots to start the engine. Run the engine approximately half throttle. Release park brake to allow the wheels to rotate.

Begin with either side and put the motion control lever into the neutral position. Adjust the motion control linkage by rotating the double nuts (D) in the proper direction until the wheel stops rotating. See illustration. Move the motion control lever forward then into the neutral position and place it into the neutral slot. The wheel must be stopped completely at this point. Now do the same in reverse and release the lever. The lever should return to neutral on its own.

Run engine full throttle to make sure wheels do not rotate. Readjust if any rotation occurs.

Repeat the whole process for the opposite side and tighten the nuts against the ball joints.

Turn machine off.

Cutter Housings

Grease housings once weekly or every 40 to 50 hours of use. Use a good synthetic grease. Pump grease in until a small amount purges from the popet on the underside of the deck. Check the torque of the pulley bolt 45 ft/lbs should be maintained.

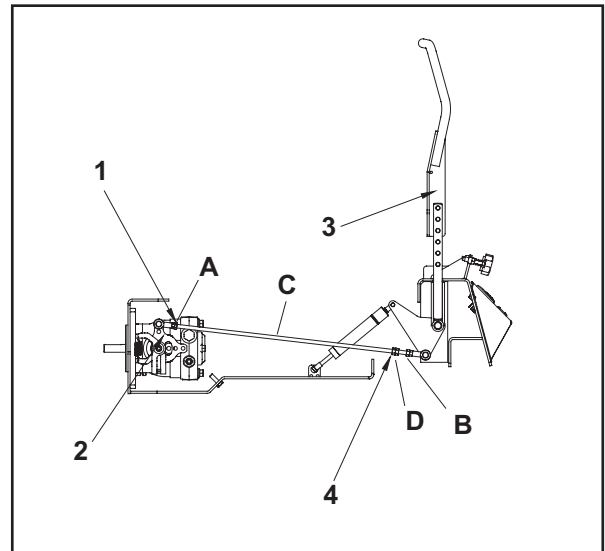

motioncontroladj

1. Left hand threads
2. Pump arm
3. Motion control lever
4. Turn here to adjust

Motion control linkage adjustment

MAINTENANCE

Deck Lift Power Unit

The system is pre-filled and factory sealed. In the event it becomes necessary to replace oil in the reservoir, the cylinder or cylinders must be in the retracted position. Carefully remove all dirt and debris from around the fill plug and remove the plug. Fill to the lower edge of the hole with 15W-50 synthetic oil and replace the plug firmly to reseal the system.

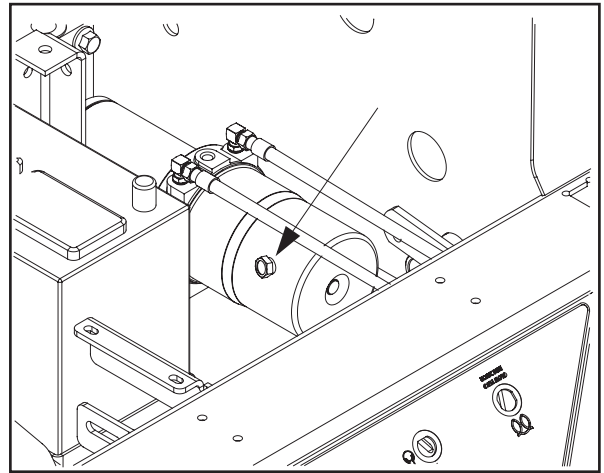

Deck Lift Power Unit Vent Plug

deckventplug

Mule Drive System Adjustment

Only for the 72" deck.

As the mule drive belt wears and elongates, some spring tension must be maintained on the left (self-adjusting) mule drive idler.

For best performance, occasionally adjust the right (fixed) mule drive idler position in the slot so central axis of idler pulleys align.

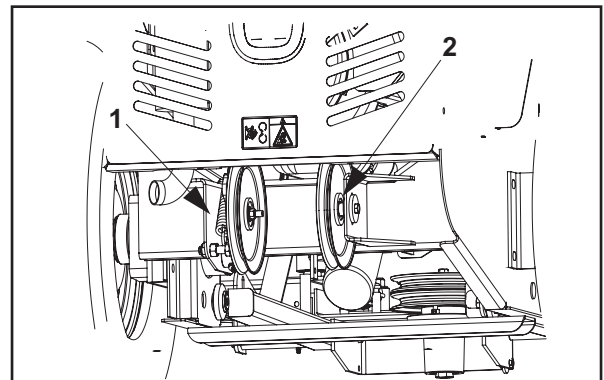

mule drive

1. Self-adjusting
2. Fixed

Mule Drive Adjustment

Caster Wheels

Check every 200 hours. Lift front of unit off of ground so caster wheels can rotate freely. Tighten caster bolt (34) then back off 1/2 turn. Check that wheel rotates freely. If wheel does not rotate freely back the caster bolt off in 1/4 turn increments until wheel rotates freely.

IMPORTANT INFORMATION

DO NOT add any type of tire liner or foam fill material to the tires. Excessive loads created by foam filled tires will cause premature failures.

Only use O.E.M. specified tires.

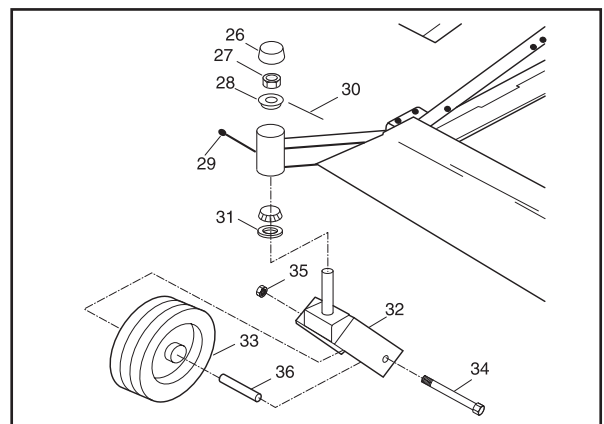

8011-619

Caster wheels

Foam filled tires or solid tires will void the warranty.

MAINTENANCE

Cleaning and Washing

Regular cleaning and washing, especially under the mower deck, will increase the machine's lifespan. Make it a habit to clean the machine directly after use (after it is cooled), before the dirt sticks.

Do not spray water on the top of the mower deck. Use compressed air to clean the top side of mower deck. Regularly clean deck and underside of deck, avoid spraying engine and electrical components with water.



Use protective glasses when cleaning and washing.



8011-644

Cleaning

Hardware

Check daily. Inspect the entire machine for loose or missing hardware.

LUBRICATION

Lubricating the Cables

If possible, grease both ends of the cables and move the controls to end stop positions when lubricating. Refit the rubber covers on the cables after lubrication. Cables with sheaths will bind if they are not lubricated regularly. If a cable binds, it can disrupt operation.

If a cable binds, remove the cable and hang it vertically. Lubricate it with light engine oil until the oil begins to escape from the bottom.

Tip: Fill a small plastic bag with oil and tape it so that it seals against the sheath and allow the cable to hang vertically from the bag overnight. If you do not succeed in lubricating the cable, it must be replaced.

Shaft Bushings and Linkage

Lubricate the bearing of the shafts and linkage for brake system and steering with oil spray or oil can.

Lubricating in Accordance with the Lubrication Schedule

1. Hydraulic System, Oil Level

The hydraulic oil and filter must be replaced every 300 hours, and at least once a year. Contact an authorized service workshop.

Check the oil level in the hydraulic tank daily. The level shall be about 3/4"-1" (19 - 25 mm) below the top of the tank.

Check connections, hoses, and tubes for damage or leaks. Replace or repair if doubtful.

Changing Oil and Filters

Oil and filter changes should be carried out by an authorized service workshop due to the risk of impurities enter the system.

2. Driver's Seat

Tip the seat.

Lubricate the front hinges using an oil can.

Lubricate the lengthways adjustment mechanism with the oil can.

Lubricate the lengthways adjustment runners with the oil can.

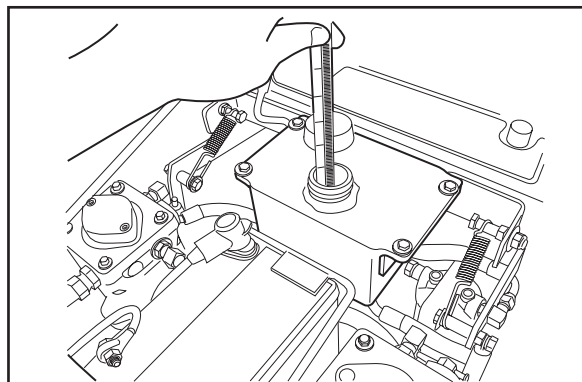

8011-565

Checking the hydraulic oil



WARNING!

If a leak is suspected, use a piece of cardboard or wood, NOT your hands, to check for leaks.

Escaping hydraulic oil under pressure can have sufficient force to penetrate the skin, causing serious injury.

If injured by escaping fluid, see a doctor at once. Serious infection or reaction can develop if proper medical treatment is not administered immediately.

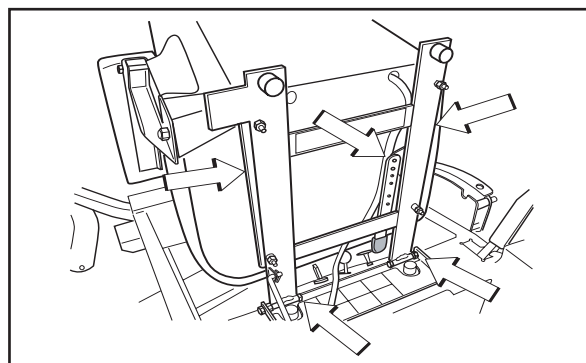

8011-571

Lubricating the lengthways adjuster under the seat

LUBRICATION

3. Engine Oil

Changing the Engine Oil

The engine oil shall be changed for the first time after 50 hours of operation. Thereafter, it should be changed every 150 hours.



WARNING!

The engine and the exhaust system, become very hot during operation.

Risk for burns if touched.

Allow engine and exhaust system to cool at least two (2) minutes.

IMPORTANT INFORMATION

Used engine oil is a health hazard and must not be disposed of on the ground or in nature; it should always be disposed of at a workshop or appropriate disposal location.

Avoid skin contact; wash with soap and water in case of spills.

1. Place the machine on a flat surface.
2. Place a container under the engine drain plug.
3. Remove the dipstick and open the drain plug.
4. Allow the oil to run out into the container.
5. Install and tighten the oil drain plug.
6. Replace the oil filter if necessary.
7. Fill with new engine oil in accordance with Checking the Oil Level.
8. Start the engine. Run it for a few seconds. Stop and re-check the oil level.

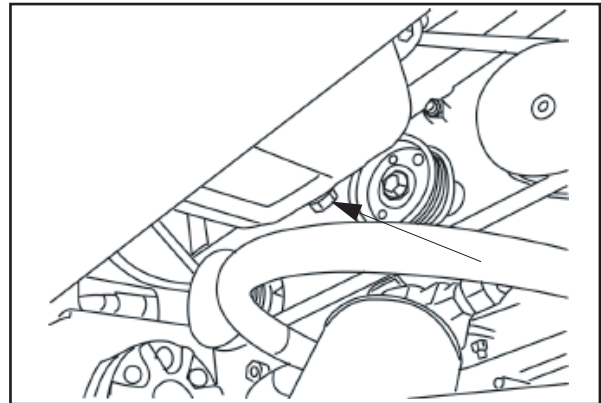

BAM-22

Oil drain plug

Checking the Oil Level

Check the oil level in the engine when the machine is standing level and the engine is stopped.

Remove the dipstick, wipe it clean, and then replace it.

Take the dipstick out again and read the oil level.

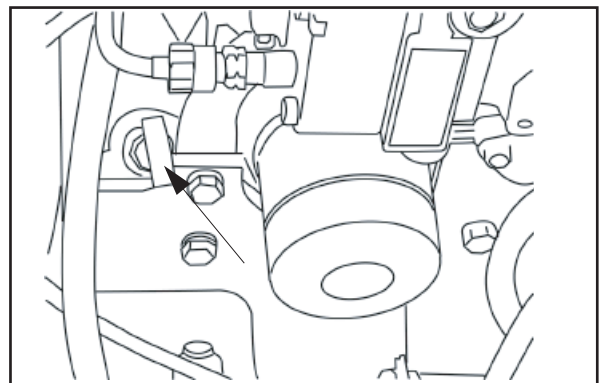

BAM-23

Remove the dipstick

LUBRICATION

The oil level shall lie between the markings on the dipstick. If the level is approaching the "ADD" mark, top up the oil to the "FULL" mark on the dipstick.

Never fill above the "FULL" mark.

The oil is filled through the hole for the dipstick.

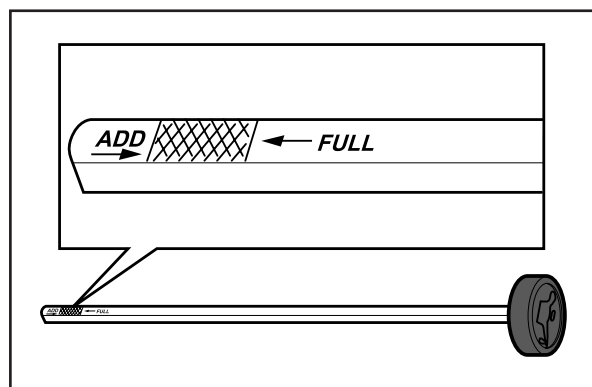

8009-159

The dipstick markings

Use engine oil SAE 30 or SAE 10W-30 or, alternately, 10W/40, class CF-4, CI-4 (over +32 °F/0 °C).

Over +68 °F /+20 °C SAE 40 can be used.

Use engine oil SAE 5W-20, class CF-4, CI-4 (under +32 °F/0 °C).

The engine holds 3.5qt/3.3 liters of oil including the filter.

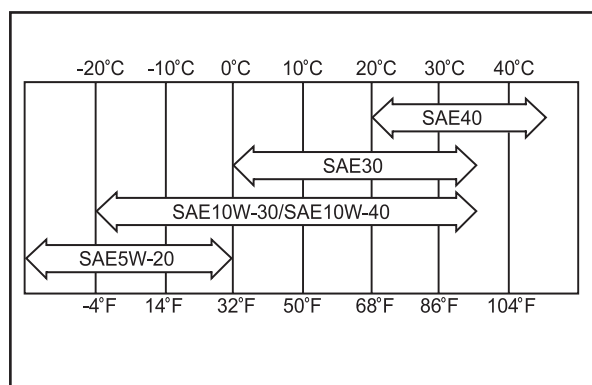

8009-140

Engine oils

4. Throttle Cable, Lever Bearings

Lubricate the cable ends by the lever with an oil can. Move the controls to the end points and lubricate again.

The throttle cable is also lubricated by the control when the control console is removed.

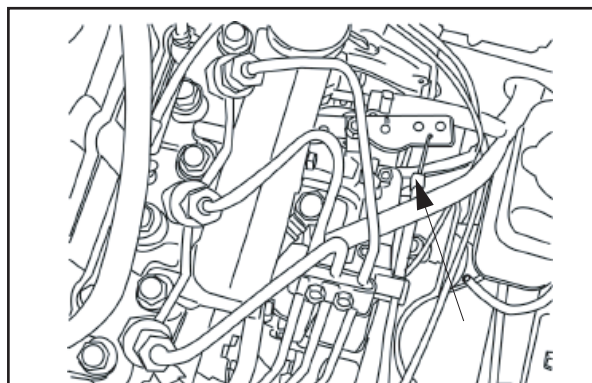

8011-605

Throttle and choke cables by the carburetor

5. Front Wheel Mount

Lubricate with a grease gun, one zerk for each wheel mount, use 10 pumps of the grease gun at the recommended service intervals. Use only good quality lithium based grease.

Use only good quality molybdenum disulphide grease.

LUBRICATION

6. Front Wheel Bearings

Lubricate with a grease gun, one zerk for each set of wheel bearings, until the grease is forced out.

Use only good quality molybdenum disulphide grease.

Grease from well-known brand names (petrochemical companies, etc.) usually maintains a good quality.

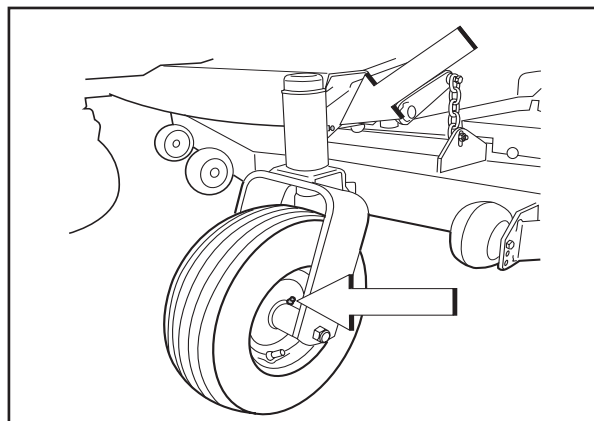

8011-573

Lubricating the front wheels

7. Belt Adjuster, Mower Deck

Remove the foot plate (two screws) and lubricate with a grease gun, one zerk, until grease is forced out.

Use only good quality molybdenum disulphide grease.

Grease from well-known brand names (petrochemical companies, etc.) usually maintains a good quality.

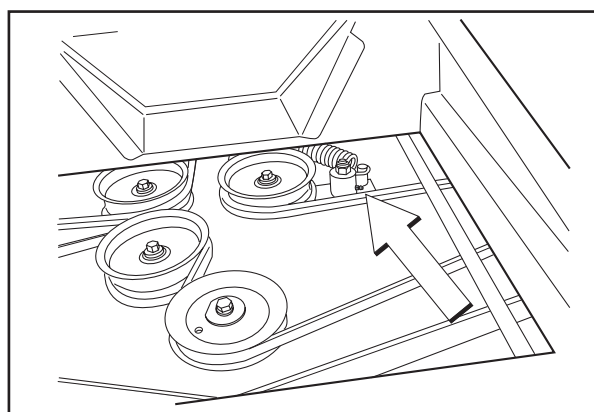

8011-461

Deck belt pulley

IMPORTANT INFORMATION

Be careful and remove excess lubricant so that it does not come into contact with belts or belt pulley drive surfaces.

8. Mower Deck Height Adjuster

Lubricate using a grease gun, one zerk, until the grease squeezes out.

Use only good quality molybdenum disulphide grease.

Grease from well-known brand names (petrochemical companies, etc.) usually maintains a good quality.

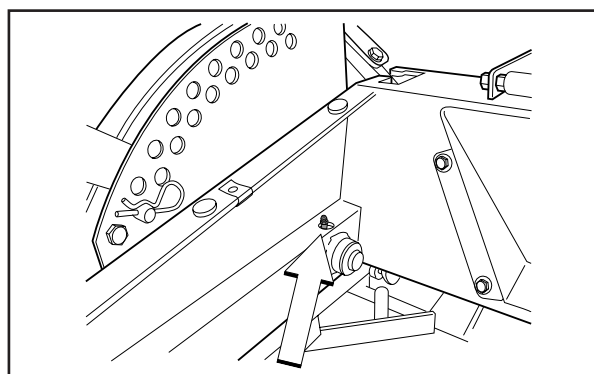

8011-574

Lubricating the cutting height adjuster

LUBRICATION

9. Steering Control Shafts

Tip the driver's seat.

Lubricate with a grease gun, one zerk for each steering control shaft, until the grease is forced out.

Use only good quality molybdenum disulphide grease.

Grease from well-known brand names (petrochemical companies, etc.) usually maintains a good quality.

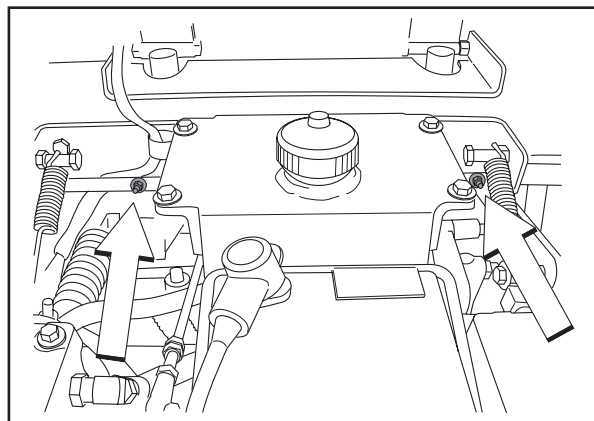

8011-578

Lubricating the steering control shafts

10. Mower Deck Struts

Lubricate with a grease gun, one zerk for each strut, until the grease is forced out.

Use only good quality molybdenum disulphide grease.

Grease from well-known brand names (petrochemical companies, etc.) usually maintains a good quality.

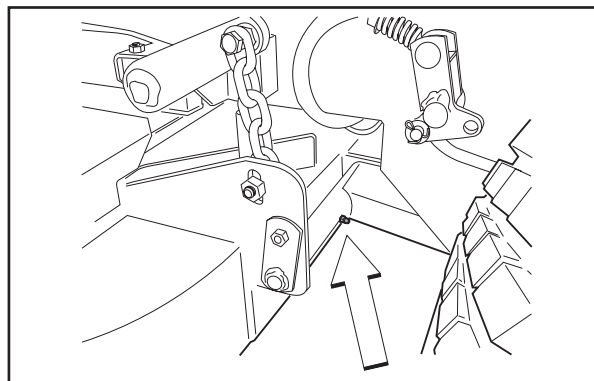

8011-577

Lubricating struts

11. Belt Adjuster- Mule Drive Idler Arm

Lubricate with a grease gun, one zerk, until the grease is forced out.

Use only good quality molybdenum disulphide grease.

Grease from well-known brand names (petrochemical companies, etc.) usually maintains a good quality.

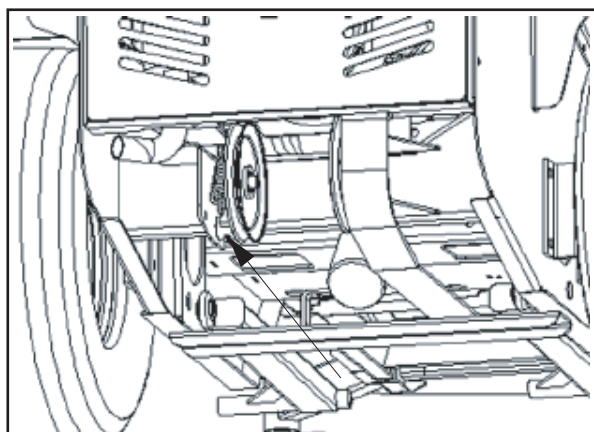

BAM-25

Lubricating mule drive idler arm

IMPORTANT INFORMATION

Be careful and remove excess lubricant so that it does not come into contact with belts or belt pulley drive surfaces.

LUBRICATION

12. Belt Adjuster, Hydraulic Pumps

Lubricate using a grease gun, one zerk, until the grease squeezes out.

Use only good quality molybdenum disulphide grease.

Grease from well-known brand names (petrochemical companies, etc.) usually maintains a good quality.

IMPORTANT INFORMATION

Use minimal lubrication and remove excess lubricant so that it does not come into contact with belts or belt pulley drive surfaces.

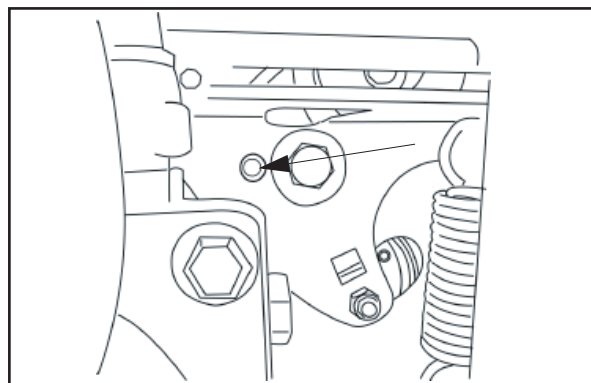

BAM-24

Lubricating the belt adjuster

13. Changing the Oil Filter

1. Drain the engine oil in following the procedure in the section, Engine Oil/ Change Engine Oil.
2. Disassemble the oil filter. If necessary, use a filter remover.
3. Partially fill the new filter with oil.
4. Wipe new, clean engine oil onto the seal for the new filter.
5. Mount the filter by hand with + 3/4 turn.
6. Run the engine warm, then check that there are no leaks around the oil filter seal.
7. Check the oil level in the engine, top off if necessary.

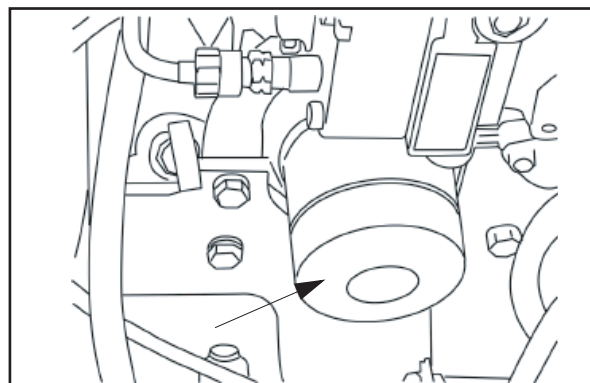

BAM-23

Changing the oil filter

TROUBLE SHOOTING GUIDE

Trouble Shooting Guide

Problem	Cause
The engine will not start.	<ul style="list-style-type: none">• The blade switch is engaged.• The steering controls are not locked in the neutral position.• The driver is not sitting in the driver's seat.• The parking brake is not activated.• The battery is dead.• Contamination in the carburetor or fuel line.• The fuel supply is closed or the tap for the fuel tanks is in the wrong position.• Clogged fuel filter or fuel line.
The starter does not turn the engine over.	<ul style="list-style-type: none">• Dead battery.• Poor contacts on the battery terminal cable connections.• Fuse blown.• Ignition system faulty.• Fault in the starter safety circuit. See Checking the Safety System in the Maintenance section.
The engine runs rough.	<ul style="list-style-type: none">• Defective valves.• Defective piston, cylinder, piston ring, or cylinder head seal.• The cylinder head bolts are loose.• Clogged fuel filter or jet.• Clogged ventilation valve on the fuel cap.• Fuel tank nearly empty.• Defective ignition cable.• Rich fuel mixture or fuel-air mixture.• Wrong fuel type.• Water in the fuel.• Clogged air filter.
The engine seems weak.	<ul style="list-style-type: none">• Clogged air filter.

TROUBLE SHOOTING GUIDE

The engine overheats.

- Clogged air intake or cooling fins.
- Engine overloaded.
- Poor ventilation around engine.
- Defective engine speed regulator.
- Soot in the combustion chamber.
- Too little or no oil in the engine.
- Pre-ignition incorrect.
- Water pump not working.
- Coolant system clogged.
- Coolant level low.

Battery not charging.

- Poor contact with battery terminal cable connectors.

The machine moves slowly, unevenly, or not at all.

- Parking brake on.
- Bypass valve on pump open.
- Drive belt for the pump slack or has come off.
- Defective hydraulic system.
- Air in the hydraulic system.

Mower deck not engaging.

- Drive belt for the mower deck has come loose.
 - Contact for the electromagnetic coupling has loosened.
 - The blade switch is faulty or has come loose from the cable contact.
 - The fuse has blown.
-

TROUBLE SHOOTING GUIDE

Uneven mowing results.

- Different air pressure in the tires on the left and right sides.
- Bent blades.
- The chains for suspending the mower deck are uneven.
- The chain fixture has come loose.
- The blades are blunt.
- Driving speed too high.
- The grass is too long.
- Grass collected under the mower deck.

The machine vibrates.

- The blades are loose.
 - The blades are incorrectly balanced.
 - The engine is loose.
 - Wheel is loose.
-

STORAGE

Storage

Winter Storage

At the end of the mowing season, the machine should be readied for storage (or if it will not be in use for longer than 30 days). Fuel allowed to stand for long periods of time (30 days or more) can leave sticky residues that can plug the carburetor and disrupt engine function.

Fuel stabilizers are an acceptable option as regards sticky residues during storage.

Add stabilizer to the fuel in the tank or in the storage container. Always use the mixing ratios specified by the manufacturer of the stabilizer. Run the engine for at least 10 minutes after adding the stabilizer so that it reaches the carburetor. Do not empty the fuel tank and the carburetor if you have added stabilizer.



WARNING!

Never store an engine with fuel in the tank indoors or in poorly ventilated spaces where fuel vapor can come in contact with open flames, sparks, or a pilot light such as in a boiler, hot water tank, clothes drier, etc. Handle the fuel with care. It is very flammable and careless use can cause serious personal injury and property damage. Drain the fuel into an approved container outdoors and far away from open flame. Never use gasoline for cleaning. Use a degreaser and warm water instead.

To ready the machine for storage, follow these steps:

1. Thoroughly clean the machine, especially under the mower deck. Touch up damage to the paint and spray a thin layer of oil on the underside of the mower deck to avoid corrosion.
2. Inspect the machine for worn or damaged parts and tighten any nuts or screws that may have become loose.
3. Change the engine oil; dispose of properly.
4. Empty the fuel tanks or add a fuel stabilizer. Start the engine and allow it to run until the carburetor is drained of fuel or the stabilizer has reached the carburetor.
5. Remove the glow plugs and pour about a tablespoon of engine oil into each cylinder. Turn over the engine so that the oil is evenly distributed and then refit the glow plugs.
6. Lubricate all grease nipples, joints, and axles.
7. Remove the battery. Clean, charge, and store the battery in a cool place, but protect it from direct cold.
8. Store the machine in a clean, dry place and cover it for extra protection.

Service

When ordering spare parts, please specify the purchase year, model, type, and serial number.

Always use genuine Husqvarna spare parts.

An annual check-up at an authorized service workshop is a good way to ensure that your machine performs its best the following season.

WIRING DIAGRAMS

Wiring diagram

6. Seat unoccupied

8. Blade switch in OFF position

11. Brake switch OFF pos.

14-15. Motion control levers OUT

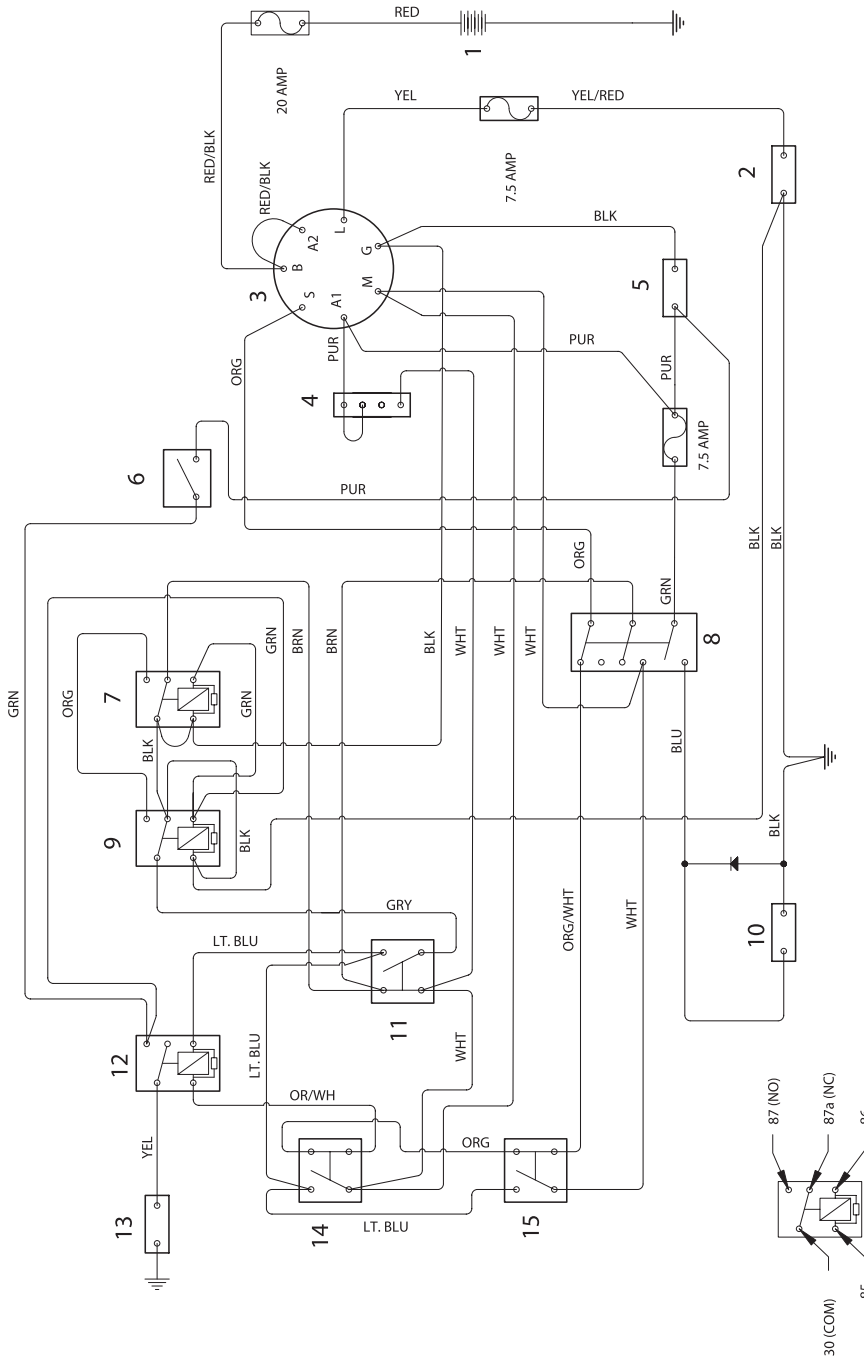
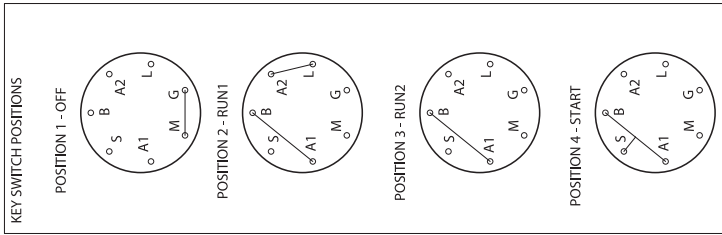

1. Battery
2. Accessory outlet
3. Key switch
4. To engine pigtail
5. Hour meter
6. Seat switch
7. Run relay
8. Blade switch
9. Brake relay
10. Electric clutch
11. Brake switch
12. Start relay
13. Starter solenoid
14. Left motion control lever
15. Right motion control lever

- BLK = Black
 BLU = Blue
 BRN = Brown
 GRN = Green
 GRY = Grey
 LT. BLU = Light Blue
 ORG = Orange
 PUR = Purple
 RED = Red
 WHT = White
 YEL = Yellow
 NO = Normally Open
 NC = Normally Closed
 COM = Common

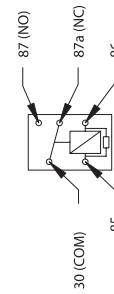

8011-650

TECHNICAL DATA

Technical Data

	BZ27	BZ34
Engine		
Manufacturer	Diahsatsu	Diahsatsu
Type	DM 950D	DM 954TD
Power	27 HP	34 HP
Lubrication	Pressure with oil filter	Pressure with oil filter
Oil capacity excl filter		
Oil capacity incl filter	3.5 qt	3.5 qt
Engine oil (See viscosity digram)	SAE 10W30, SAE 30, 10W40 class SC-SH,	SAE 10W30, SAE 30, 10W40 class SC-SH,
Fuel	Diesel with a minimum of 40 octane	Diesel with a minimum of 40 octane
Fuel tank capacity	11.4 gallons / 43 liters.	11.4 gallons / 43 liters
Cooling	Liquid-cooled	Liquid-cooled
Air filter	Heavy duty canister	Heavy duty canister
Alternator	12 V 15 A	12 V 15 A
Starter	Electric	Electric
Transmission		
Transmission	Hydro gear Ross / Dual pumps, Wheel drive motor	Hydro gear Ross / Dual pumps, Wheel drive motors
Speed and direction controls	Dual levers, foam gripped	Dual levers, foam gripped
Speed forward	0-11.5 mph	0-11.5 mph
Speed reverse	0-5 mph	0-5 mph
Brakes	Hydrostatic/brake linings	Hydrostatic/brake linings
Front caster tires, Smooth tread	13x6.50-6 Tubeless	13x6.50-6 Tubeless
Rear tires, Turf pneumatic	26x12.00-12 Tubeless	26x12.00-12 Tubeless
Tire pressure, front and rear	15 PSI / 103 kPa / 1 bar	15 PSI / 103 kPa / 1 bar
Hydraulic reservoir + system	1 1/8 gallon	1 1/8 gallon
Hydraulic oil	Full synthetic 15W-50	Full synthetic 15W-50

TECHNICAL DATA

	BZ27	BZ34
Equipment		
Cutting width	61 in	61 in and 72 in.
Cutting height (Tunnel Ram Deck)	1.5"- 6" / 3.8 - 15.5 cm	1.5"- 6" / 3.8 - 15.5 cm
Cutting height (Combi Deck)	1.25"- 5.75" / 3.2 - 14.6 cm	
Uncut circle	0	0
Number of blades	3	3
Blade length (Tunnel Ram Deck)	21"/533 mm - 61"	25"/635mm - 72"
Blade length (Combi Deck)	22.17"/536 mm - 61"	
Blade tip speed	N/A	N/A
Anti-scalp rollers-Tunnel Ram Deck	6-adjustable	8, 6-adjustable
Anti-scalp rollers-Combi Deck	4-adjustable	
Frame construction	Steel uni-frame	Steel uni-frame
Ball beared wheels	Yes	Yes
Sprung standard seat	Standard High-Back	
Hinged armrests	Yes	
Hour meter	Digital with service intervals	
Blade engagement	300 ft/lb Warner Mag-stop Electromagnetic clutch	
Deck construction-Tunnel Ram Deck	7 Gauge tunnel and sides, 10 Gauge top and spindle reinforcement	
Deck construction-Combi Deck	4.5 mm Stamped Shell	
Productivity		
Productivity	N/A	
Overall dimensions		
Weight	1540 lbs.	1620 lbs.
Base machine length	95"	95"
Base machine width		
Base machine height	46.5"	46.5"
Overall width, Chute up Tunnel Ram Deck	62"	73"
Overall width, Chute up Combi Deck	63"	74"
Overall width, Chute down-Tunnel Ram Deck	74"	85"
Overall width, Chute down-Combi Deck	N/A	N/A

TECHNICAL DATA

Accessories

Front baffle kit

Mulch kits

ROPS Roll Over Protection System

Torque Specifications

·Engine crankshaft bolt	50 ft/lb (67 Nm)
·Deck pulley bolts-Tunnel Ram Deck	45 ft/lb (61 Nm)
·Deck pulley bolts-Combi Deck	57-61 ft/lb (77-82 Nm)
·Hydraulic tube nuts	30 ft/lb (41 Nm)
·Wheel motor hub nut	90 ft/lb (122 Nm)
·Lug nuts	75 ft/lb (100 Nm)
·Blade bolt -Tunnel Ram Deck	90 ft/lb (122 Nm)
·Blade bolt -Combi Deck	57-61 ft/lb (77-82 Nm)
·Standard 1/4" fasteners	9 ft/lb (12 Nm)
·Standard 5/16" fasteners	18 ft/lb (25 Nm)
·Standard 3/8" fasteners	33 ft/lb (44 Nm)
·Standard 7/16" fasteners	52 ft/lb (70 Nm)
·Standard 1" fasteners	80 ft/lb (110 Nm)

When this product is worn out and no longer used, it shall be returned to the reseller or other party for recycling.

In order to implement improvements, specifications and designs can be altered without prior notification.

Note that no legal demands can be placed based on the information contained in these instructions.

Use only original parts for repairs. The use of other parts voids the warranty.

Do not modify or install non-standard equipment to the unit without consent from the manufacturer. Modifications to the unit may cause unsafe operation or damage the unit.

CONFORMITY CERTIFICATES

Conformity Certificates For Models Listed Below:

Model 968999315/BZ27 (Serial Numbers: 054600001 – 065299999)

Model 968999316/BZ34 (Serial Numbers: 054600001 – 065299999)

With Deck Model 968999345 TRD61B

Deck Model 968999346 TRD72B

Deck Model 968999350 CD61B

EU declaration of conformity

Only applicable to European versions

Husqvarna AB, Beatrice NE USA declares under sole responsibility that the machine types stated on page 1 of this manual, from 2005's serial numbers and onwards (the year is clearly stated in plain text on the rating plate with subsequent serial number), complies with the requirements of the COUNCIL'S DIRECTIVES:

- of June 22, 1998 "relating to machinery" 98/37/EC, annex IIA.
- of May 3, 1989 "relating to electromagnetic compatibility" 89/336/EEC, and applicable supplements.
- of May 8, 2000 "relating to the emission of noise to surroundings" 2000/14/EC. Conformity assessment according to Annex V.

The following harmonised standards have been applied: EN292-2, EN836.

Noise emissions and cutting width:

Measured noise level:

Bio 90: 99 dB(A)

Combi 103: 99 dB(A)

Combi 103: 100 dB(A)

Guaranteed noise level:

100 dB(A)

Cutting width:

900 - 1120 mm/35.5-44"

Beatrice January 3, 2005

Husqvarna 401 North Commerce Street, Beatrice, NE 68310 USA



Richard Bednar, Design Manager

SERVICE JOURNAL

Service Journal

Action	Date, mtr reading, stamp, sign
Delivery Service	
1. Charge the battery.	<input type="checkbox"/>
2. Mount the rear wheels.	<input type="checkbox"/>
3. Adjust the tire pressure of all wheels to 15 PSI (1 bar).	<input type="checkbox"/>
4. Mount the steering controls in the normal position.	<input type="checkbox"/>
5. Connect the seat fold-up stop.	<input type="checkbox"/>
6. Connect the cable to the safety switch under the seat.	<input type="checkbox"/>
7. Mount the arm rests on the seat's back support.	<input type="checkbox"/>
8. Check that the right amount of oil is in the engine.	<input type="checkbox"/>
9. Check that the right amount of oil is in the hydraulic tank.	<input type="checkbox"/>
10. Adjust the position of the steering controls.	<input type="checkbox"/>
11. Fill with fuel and open the fuel valve.	<input type="checkbox"/>
12. Check that the machine has no transport damage.	<input type="checkbox"/>
13. Start the engine.	<input type="checkbox"/>
14. Check that there is drive to both wheels.	<input type="checkbox"/>
15. Vent the hydraulic system if necessary.	<input type="checkbox"/>
16. Check the mower deck adjustment.	<input type="checkbox"/>
17. Check:	
The safety switch for the parking brake.	<input type="checkbox"/>
The safety switch for the mower deck.	<input type="checkbox"/>
The safety switch in the seat.	<input type="checkbox"/>
The safety switch in the steering controls.	<input type="checkbox"/>
Parking brake functionality.	<input type="checkbox"/>
Driving forward.	<input type="checkbox"/>
Driving backward.	<input type="checkbox"/>
Engaging the blades.	<input type="checkbox"/>
18. Check the idle speed.	<input type="checkbox"/>
19. Check the engine high idle speed.	<input type="checkbox"/>

SERVICE JOURNAL

Action	Date, mtr reading, stamp, sign
<p>20. Inform the customer about:</p> <ul style="list-style-type: none">The need and advantages of following the service schedule.The need and advantages of leaving the machine for service every 300 hours.The effects of service and maintaining a service journal on the machine's resale value.Application areas for BioClip. <p>21. Fill in the sales papers, etc.</p>	<p>Delivery service has been carried out.</p> <p>No remaining notes.</p> <p>Certified:</p>
<p>After the First 50 Hours</p> <p>1. Change engine oil and filter.</p>	<input type="checkbox"/>

SERVICE JOURNAL

Action	Date, mtr reading, stamp, sign
<p>25-Hour Service</p> <ol style="list-style-type: none">1. Check the hydraulic system's oil level.2. Check the tire pressures.3. Lubricate the belt adjuster, mower deck.4. Lubricate the belt adjuster, hydraulic pumps.5. Check/clean the engine's cooling air intake.6. Clean cyclon air filter dust cap.7. Lubricate the belt adjuster, mule drive - 72" only.	

SERVICE JOURNAL

Action	Date, mtr reading, stamp, sign
<p>50-Hour Service</p> <ol style="list-style-type: none">1. Perform the 25-hour service.2. Lubricate the front wheel bearings.3. Lubricate the steering control shafts.4. Lubricate the mower deck struts.5. Lubricate the cutting height adjuster.6. Change oil and oil filter for the first time. See engine manual.7. Check dust load indicator on air filter. Change filter only if indicator is red. See engine manual.8. Check/adjust the parking brake.	

SERVICE JOURNAL

Action	Date, mtr reading, stamp, sign
<p>100-Hour Service</p> <ol style="list-style-type: none">1. Perform the 25-hour service.2. Perform the 50-hour service.3. Change engine oil at 150 hours. See engine manual.4. Check fuel pump filter. See engine manual.5. Check fan belt clearance. See engine manual.6. Clean the cooling fins on the engine and transmission.	

SERVICE JOURNAL

Action	Date, mtr reading, stamp, sign
<p>300-Hour Service</p> <ol style="list-style-type: none">1. Inspect the machine. Come to agreement with the customer as to which additional work is to be carried out.2. Perform the 25-hour service.3. Perform the 50-hour service.4. Perform the 100-hour service.5. Change the oil and filter in the hydraulic system.6. Clean the combustion chamber and grind the valve seats.7. Check the engine valve clearance.8. Dismantle, clean and inspect starter (500 hours).9. Check/replace the air cleaner's safety element.	

SERVICE JOURNAL

Action	Date, mtr reading, stamp, sign
<p>At Least Once Each Year</p> <ol style="list-style-type: none">1. Clean the engine's cooling air intake (25 hours).2. Replace the air cleaner's paper cartridge.3. Replace the air filter's main cartridge (200 hours).4. Change the engine oil (150 hours).5. Replace the engine oil filter (300 hours).6. Change the oil and filter in the hydraulic system (300 hours).7. Check/adjust the cutting height.8. Check/adjust the parking brake (50 hours).9.. Change the fuel filter (100 hours).10. Clean the cooling fins (100 hours).11. Check the play in the engine valves (300 hours).12. Perform the 300-hour service at an authorized service workshop.	

115 02 43-26



2006W18