



YTH200 Twin

Spare parts

Ersatzteile

Pièces détachées

Reserve onderdelen

Repuestos

Reservdelar

ILLUSTRATED PARTS LIST

MODEL NO. 96041006300
CUSTOMER CATALOG NO. YTH200 TWIN
PRODUCT NO. 960 41 00-63

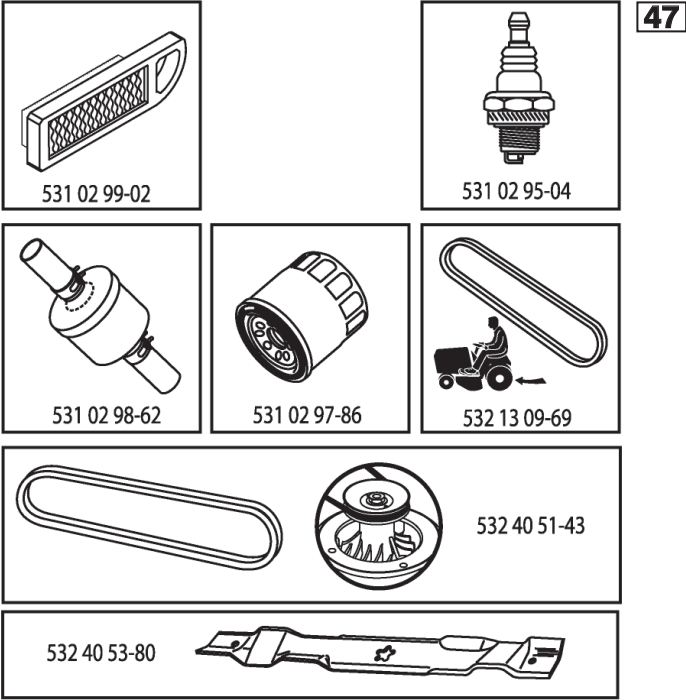

415747

**TRACTOR -- MODEL NO. YTH200 TWIN (96041006300), PRODUCT NO. 960 41 00-63
DECALS 27**

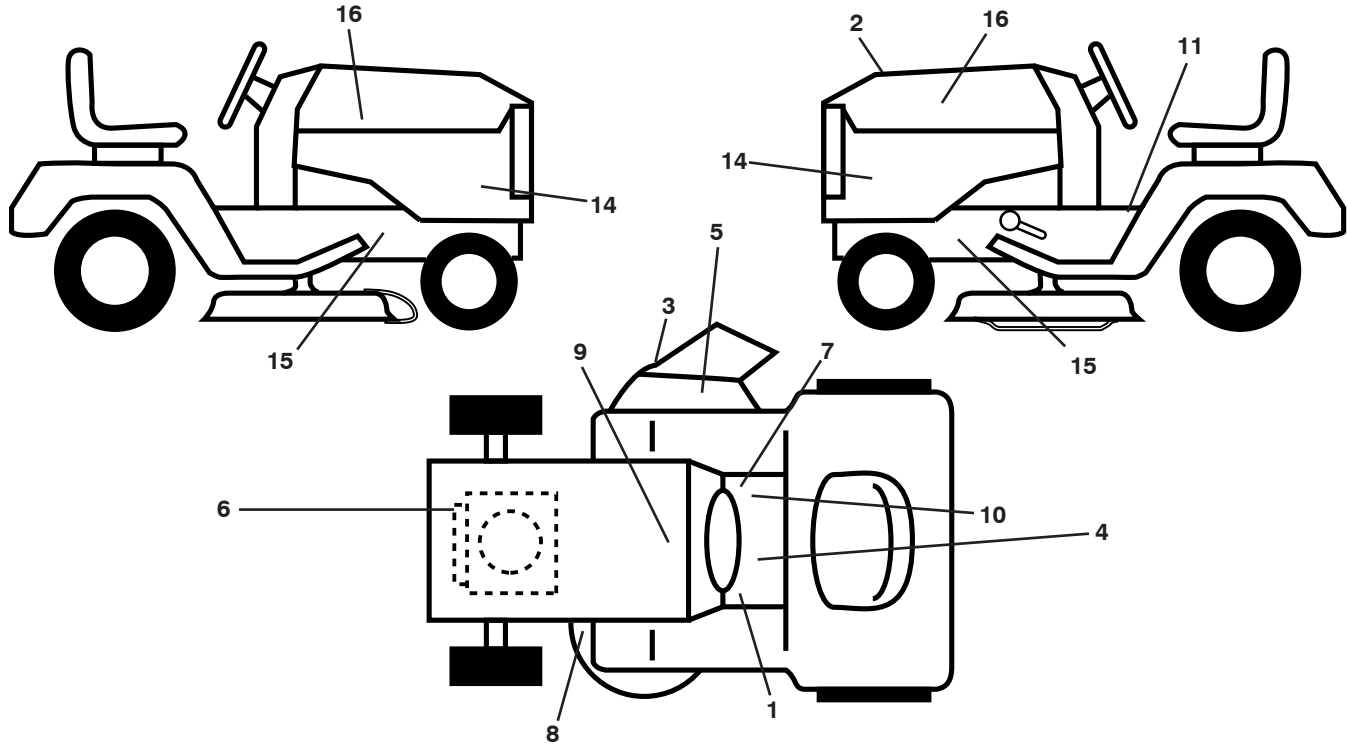

**KEY PART
NO. NO.**

KEY PART NO. NO.	DESCRIPTION
1 532 15 97-37	Decal, Brake/Clutch Sym
2 532 41 57-47	Decal, RPL
3 532 19 63-57	Decal, Warning Deflect. Cutfinger
4 532 18 04-32	Decal, Fender
5 532 18 21-66	Decal, Cutfinger CE
6 532 19 68-41	Decal, Warning Eng. Syms.
7 532 14 08-37	Decal, Saddle Brake Parking
8 532 16 03-96	Decal, Mower Sch. V-Belt
9 532 14 50-05	Decal, Battery Dan./Poi.
10 532 17 83-02	Decal, Oper. Cruise Sym.
11 532 40 03-89	Decal, Warning Sym. CE

**KEY PART
NO. NO.**

KEY PART NO. NO.	DESCRIPTION
14 532 41 60-14	Decal, Panel Side
15 532 15 97-36	Decal, Chassis Hot Muffler
16 532 40 28-32	Decal, Hood Logo
-- 532 16 69-60	Decal, Bypass
-- 532 40 17-71	Pad, Footrest, LH
-- 532 40 37-73	Pad, Footrest, RH
-- 532 16 25-98	Decal, Drawbar Load
-- 532 41 60-72	Manual, Operator's Euro
-- 532 41 60-73	Manual, Operator's Scand
-- 532 41 60-74	Manual, Operator's E-Bloc
-- 532 41 60-75	Manual, Operator's Baltic

WHEELS AND TIRES

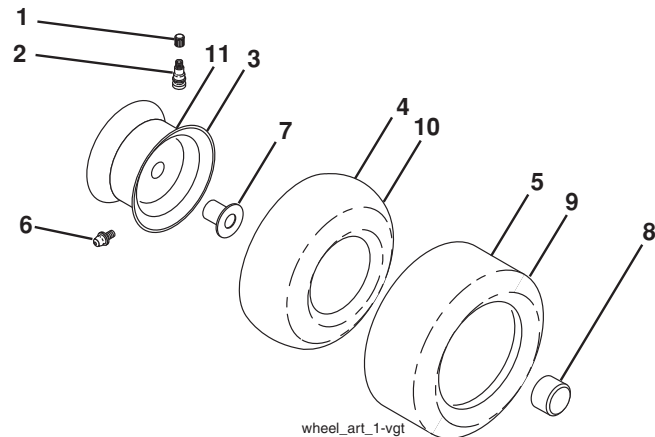

**KEY PART
NO. NO.**

KEY PART NO. NO.	DESCRIPTION
1 532 05 91-92	Cap, Valve, Tire
2 532 06 51-39	Stem, Valve
3 532 13 83-36	Rim Assembly, Front
4 532 05 99-04	Tube, Front (Service Item Only)
5 532 10 62-22	Tire, Front
6 532 12 49-57	Fitting, Grease (Front Wheel Only)
7 532 12 49-59	Bearing, Flange (Front Wheel Only)
8 532 17 50-39	Cap, Axle (Front Wheel Only)
9 532 12 20-82	Tire, Rear
10 532 12 49-26	Tube, Rear (Service Item Only)
11 532 13 83-37	Rim Assembly, Rear
-- 532 14 43-34	Sealant, Tire (10 oz. Tube)

NOTE: All component dimensions given in U.S. inches
1 inch = 25.4 mm

TRACTOR -- MODEL NO. YTH200 TWIN (96041006300), PRODUCT NO. 960 41 00-63

SCHEMATIC 38

SCH13

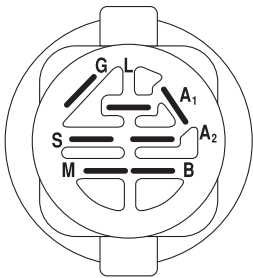
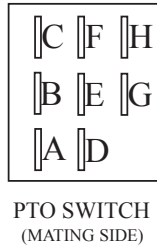
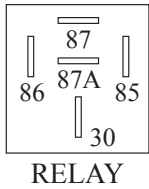
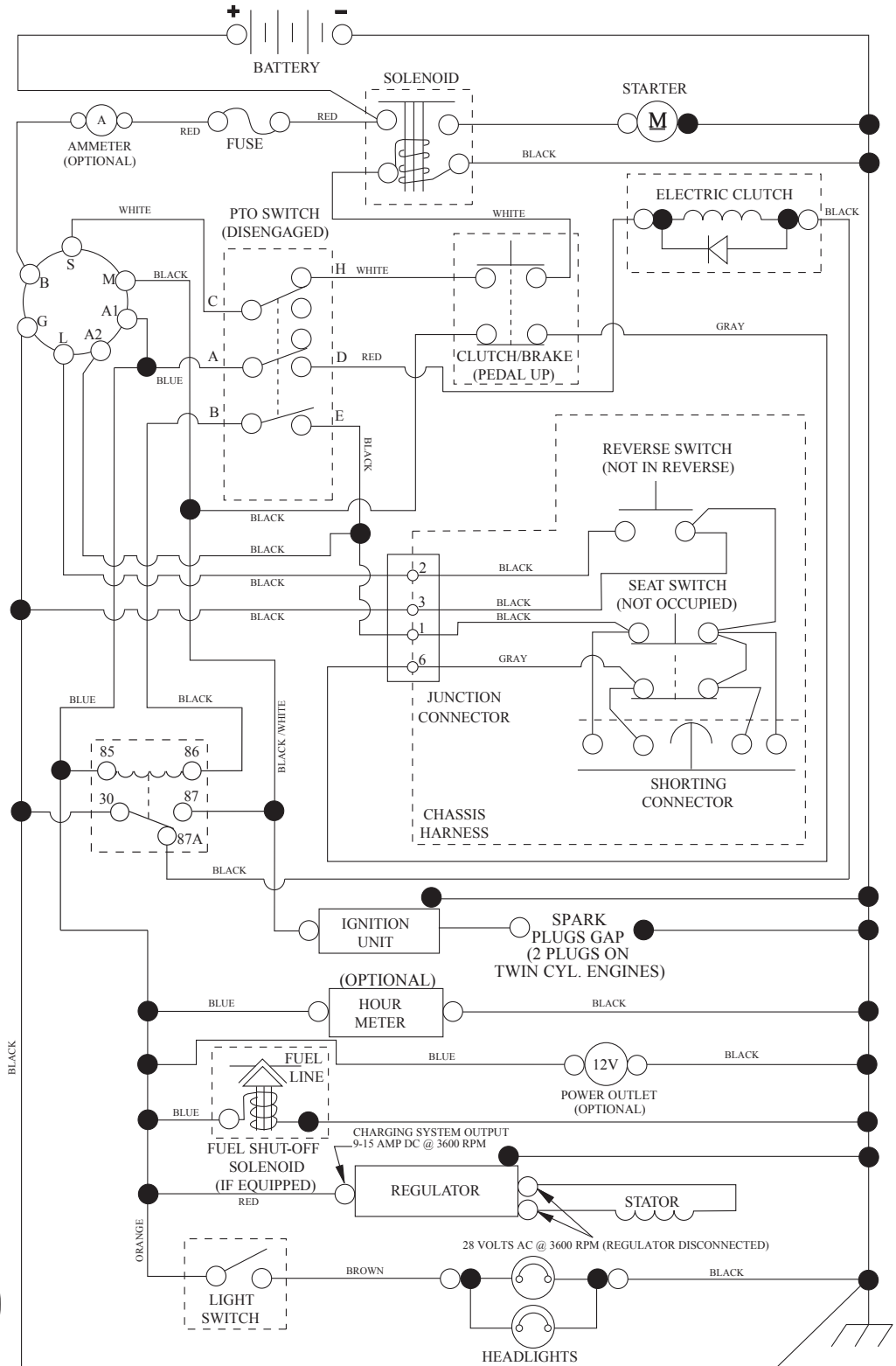

POSITION	CIRCUIT	"MAKE"
OFF	M+G+A1	
RUN/OVERRIDE	B+A1	
RUN	B+A1	L+A2
START	B + S + A1	

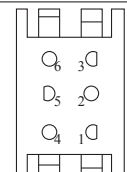
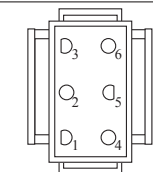

WIRING INSULATED CLIPS
NOTE: IF WIRING INSULATED CLIPS WERE REMOVED FOR SERVICING OF UNIT, THEY SHOULD BE RE-INSTALLED TO PROPERLY SECURE YOUR WIRING.

NON-REMOVABLE CONNECTIONS

REMOVABLE CONNECTIONS

TRACTOR -- MODEL NO. YTH200 TWIN (96041006300), PRODUCT NO. 960 41 00-63
ELECTRICAL 32

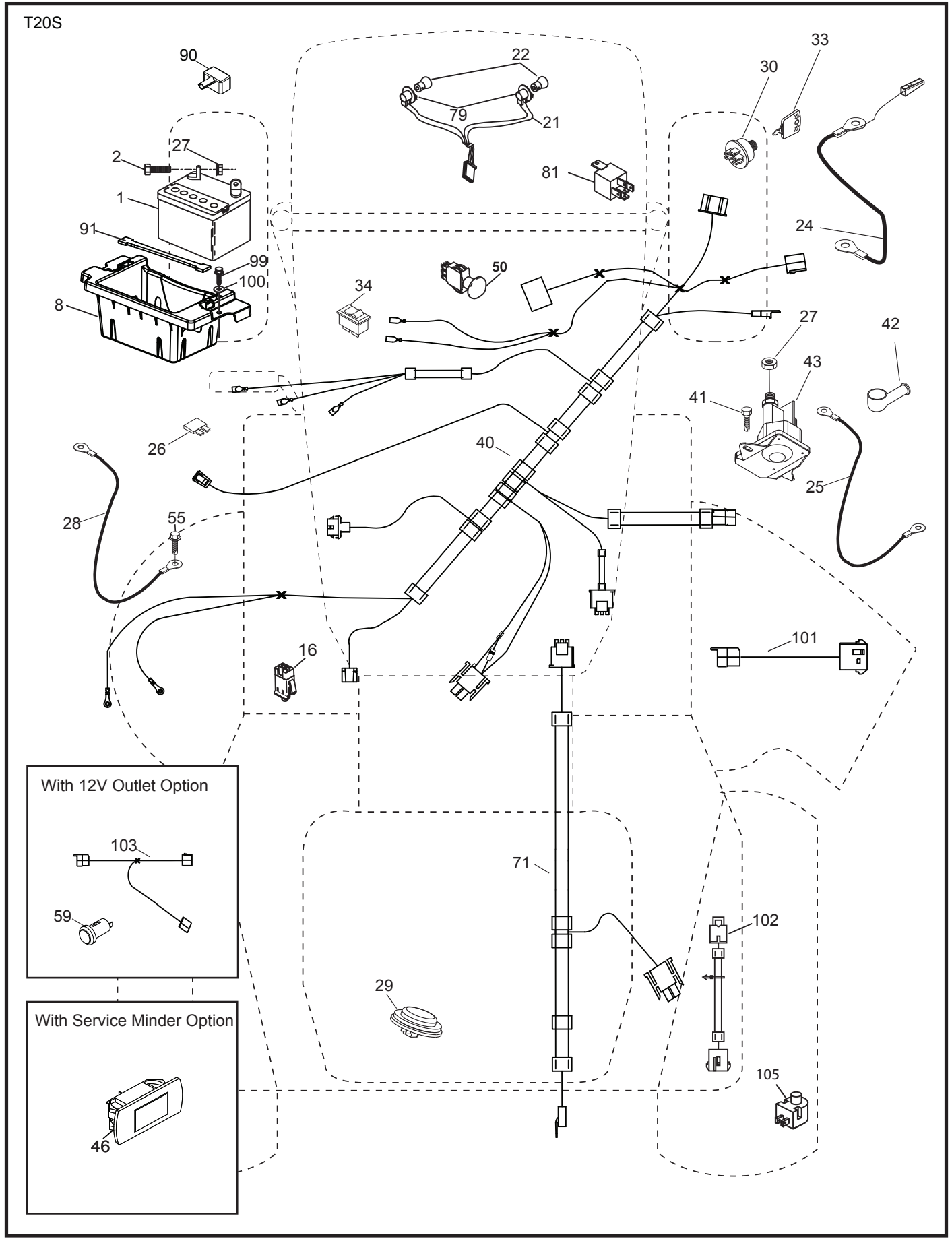

**TRACTOR -- MODEL NO. YTH200 TWIN (96041006300), PRODUCT NO. 960 41 00-63
ELECTRICAL 32**

KEY NO.	PART NO.	DESCRIPTION
1	532 16 34-65	Battery
2	874 76 04-12	Bolt Hex Hd. 1/4-20 unc x 3/4
8	532 18 64-91	Battery Box
16	532 17 61-38	Switch Interlock
21	532 18 37-59	Harness Socket Light
22	532 00 41-52	Bulb, Light # 1156
24	532 40 02-53	Cable Battery
25	532 41 28-95	Cable Starter
26	532 17 51-58	Fuse
27	873 51 04-00	Nut Keps Hex 1/4-20 unc
28	532 14 54-91	Cable Ground 21" Blk. 6 Ga.
29	532 40 15-45	Switch Seat
30	532 19 33-50	Switch Ign.
33	532 41 19-35	Key/Chain
34	532 11 07-12	Switch Light/Reset
40	532 40 96-14	Harness Ignition Dash
41	817 72 04-08	Screw Thd. Cut 1/4-20 x 1/2
42	532 13 15-63	Cover Terminal Red
43	532 19 25-07	Solenoid
46	532 41 39-31	Gauge Hourmeter
50	532 17 46-51	Switch PTO
55	817 06 05-12	Screw Thdrol. 5/16-18 x 3/4
71	532 19 42-76	Harness Chassis
79	532 17 52-42	Socket Asm. Bulb
81	532 40 96-15	Relay Harness Sealed
90	532 40 07-24	Cover Terminal Battery
91	532 19 02-70	Strap Battery
99	817 67 04-12	Screw Hex Wsh. Thdrol. 1/4-20 x 3/4
100	819 09 14-16	Washer 9/32 x 7/8 x 16 Ga.
101	532 19 83-17	Pigtail Harness Clutch
102	532 40 44-54	Harness Pigtail
105	532 40 75-68	Switch Reverse

NOTE: All component dimensions given in U.S. inches
1 inch = 25.4 mm

**TRACTOR -- MODEL NO. YTH200 TWIN (96041006300), PRODUCT NO. 960 41 00-63
CHASSIS AND ENCLOSURES 39**

KEY PART NO. NO.	DESCRIPTION	KEY PART NO. NO.	DESCRIPTION
3	532 40 50-12	194	873 90 05-00
5	532 40 87-01	195	532 40 41-37
14	532 41 10-46	196	532 40 02-99
15	532 19 89-07	199	532 19 82-59
18	532 40 86-07	202	532 40 30-48
25	532 19 89-06	203	532 40 30-76
34	532 19 61-25	204	532 19 89-04
36	817 06 05-12	205	532 40 17-09
37	532 40 18-25	206	532 40 17-11
52	873 68 05-00	207	532 19 71-98
58	532 41 22-81	208	532 19 71-99
68	817 49 05-08	209	532 19 91-30
130	532 19 16-11	210	532 19 91-31
137	532 40 75-90	211	532 19 91-32
150	532 19 85-12	212	532 19 91-33
152	532 19 95-35	213	874 76 05-12
159	817 00 06-12	214	532 19 91-45
161	532 40 18-26	217	532 40 91-67
162	532 14 24-32	218	532 19 63-95
165	532 19 68-26	221	532 19 89-09
175	532 19 63-04	228	532 19 51-61
176	532 40 07-76	230	532 17 01-65
177	532 19 52-27	234	532 40 47-42
178	532 19 97-82	235	532 40 61-29
180	532 41 50-64	236	873 93 05-00
181	532 40 30-25	238	532 40 86-06
182	532 40 68-59	239	532 11 04-52
183	874 78 05-20		
189	817 00 05-12		

NOTE: All component dimensions given in U.S. inches
1 inch = 25.4 mm

TRACTOR -- MODEL NO. YTH200 TWIN (96041006300), PRODUCT NO. 960 41 00-63
DRIVE **40**

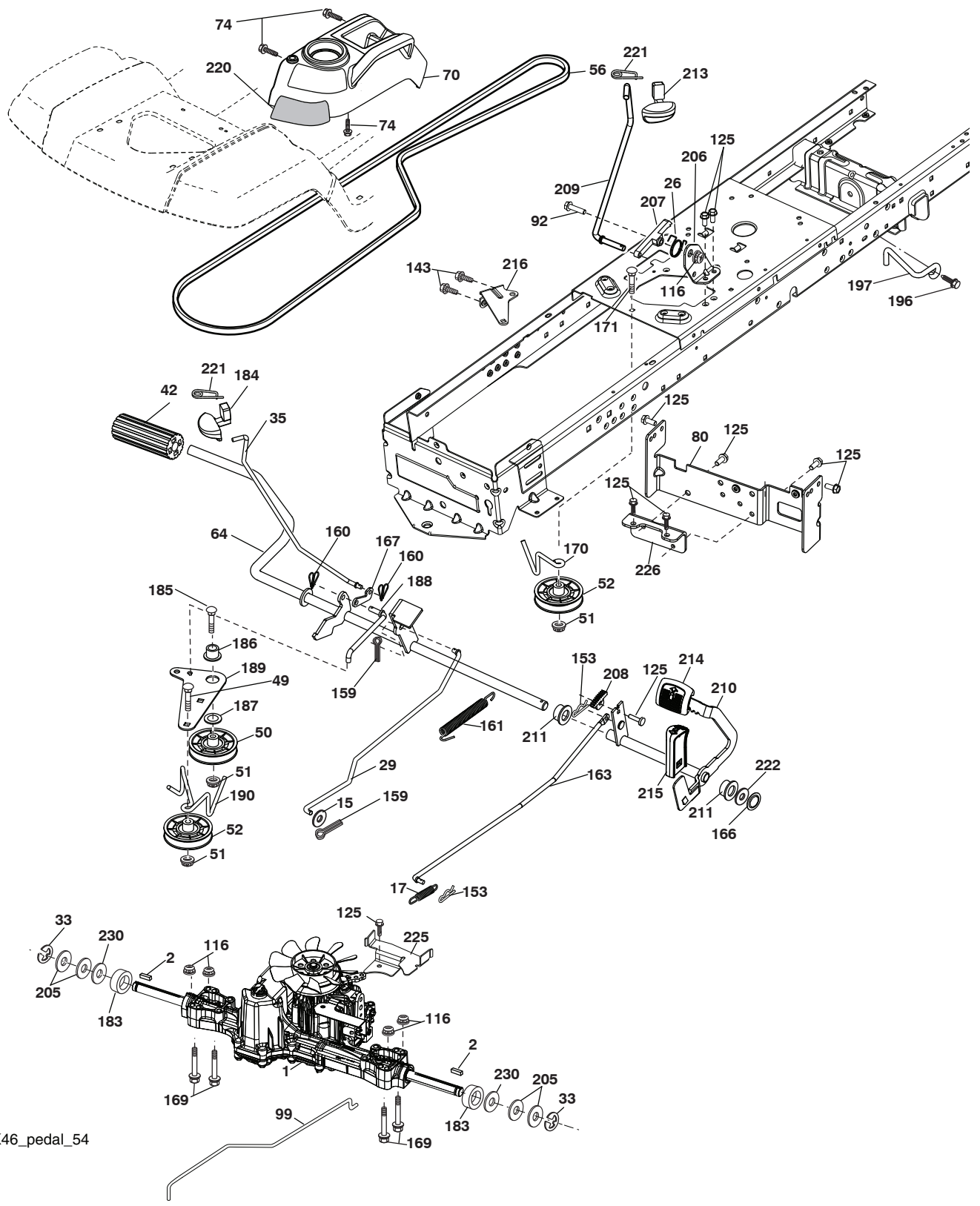

drive-tex_K46_pedal_54

**TRACTOR -- MODEL NO. YTH200 TWIN (96041006300), PRODUCT NO. 960 41 00-63
DRIVE **40****

KEY NO.	PART NO.	DESCRIPTION	KEY NO.	PART NO.	DESCRIPTION
1	---	Transaxle, TUFFTORQ K46 BT	171	872 11 06-16	Bolt Rdhd. Sqnk. 3/8-16 unc x 2
2	532 12 35-83	Key 1/4 x 2.5	183	532 13 70-57	Spacer Split
15	819 13 13-16	Washer 13/32 x 13/16 x 16 Ga.	184	532 40 31-18	Handle Parking Brake
17	532 41 36-78	Spring, Brake	185	872 11 06-20	Bolt Rdhd. Sqnk. 3/8-16 x 2-1/2
26	532 19 96-79	Spring Return Cruise	186	532 19 43-21	Spacer Retainer
29	532 40 38-06	Rod, Brake	187	819 13 32-10	Washer
33	812 00 00-01	Ring E	188	532 19 43-23	Link Clutch Ground Drive
35	532 19 95-91	Rod, Brake, Park	189	532 19 43-17	Bellcrank Ground Drive
42	532 12 48-72	Cover, Foot Pedal	190	532 19 43-18	Keeper Bellcrank Ground Drive
49	872 11 06-14	Bolt	196	817 00 06-16	Screw 3/8-16 x 1
50	532 19 43-27	Pulley Idler Flat	197	532 19 58-04	Link Clutch Anti-Rotation
51	873 90 06-00	Lock Nut 3/8-16	205	532 12 17-48	Washer
52	532 19 43-26	Idler V-Groove 910" Offset	206	532 19 78-67	Bracket Mount Latch Cruise
56	532 13 09-69	V-Belt, Drive	207	532 19 78-68	Latch Control Cruise
64	532 19 78-65	Shaft Asm. Pedal Brake Control	208	532 19 78-69	Gear Sector Control Cruise
70	532 40 05-30	Console Asm.	209	532 19 95-92	Rod Control Cruise
74	532 14 24-32	Screw 1/4 x 1/2	210	532 19 78-60	Rocker Asm. Pedal Control
80	532 41 00-24	Bracket Strap Torque	211	532 12 01-83	Bearing Nylon
92	874 76 05-20	Bolt Fin. Hex 5/16-18 unc x 1.25	213	532 40 31-19	Knob Control Cruise
99	532 40 59-03	Rod Bypass	214	532 40 17-22	Pedal Forward
116	873 90 05-00	Nut Lock Hex Flange 5/16-18	215	532 40 17-23	Pedal Reverse
125	817 00 05-12	Screw 5/16-18 x 3/4	216	532 19 61-31	Bracket Pulley Idler
143	817 49 05-08	Screw 5/16-18 x 1/2	220	532 19 89-08	Reflector RH
153	532 12 47-88	Retainer Spring	221	532 40 31-87	Retainer Spring Clip Handle
159	876 02 04-12	Pin Cotter 1/8 x 3/4	222	879 21 20-10	Washer 21/32 x 1-1/4 x 10 Ga.
160	532 16 94-84	Retainer Clip	225	532 40 33-19	Keeper Belt Trans.
161	532 10 57-09	Spring, Return, Clutch	226	532 40 15-64	Bracket Mount Torque
163	532 40 10-34	Rod Pedal Control	230	532 18 89-67	Washer Hardened
166	532 19 72-90	Nut Push .625			
167	532 40 52-57	Latch Brake Parking			
169	874 49 05-44	Bolt Hex Flghd. 5/16-18 x 3.75			
170	532 19 43-22	Keeper Belt Centerspan			

NOTE: All component dimensions given in U.S. inches
1 inch = 25.4 mm

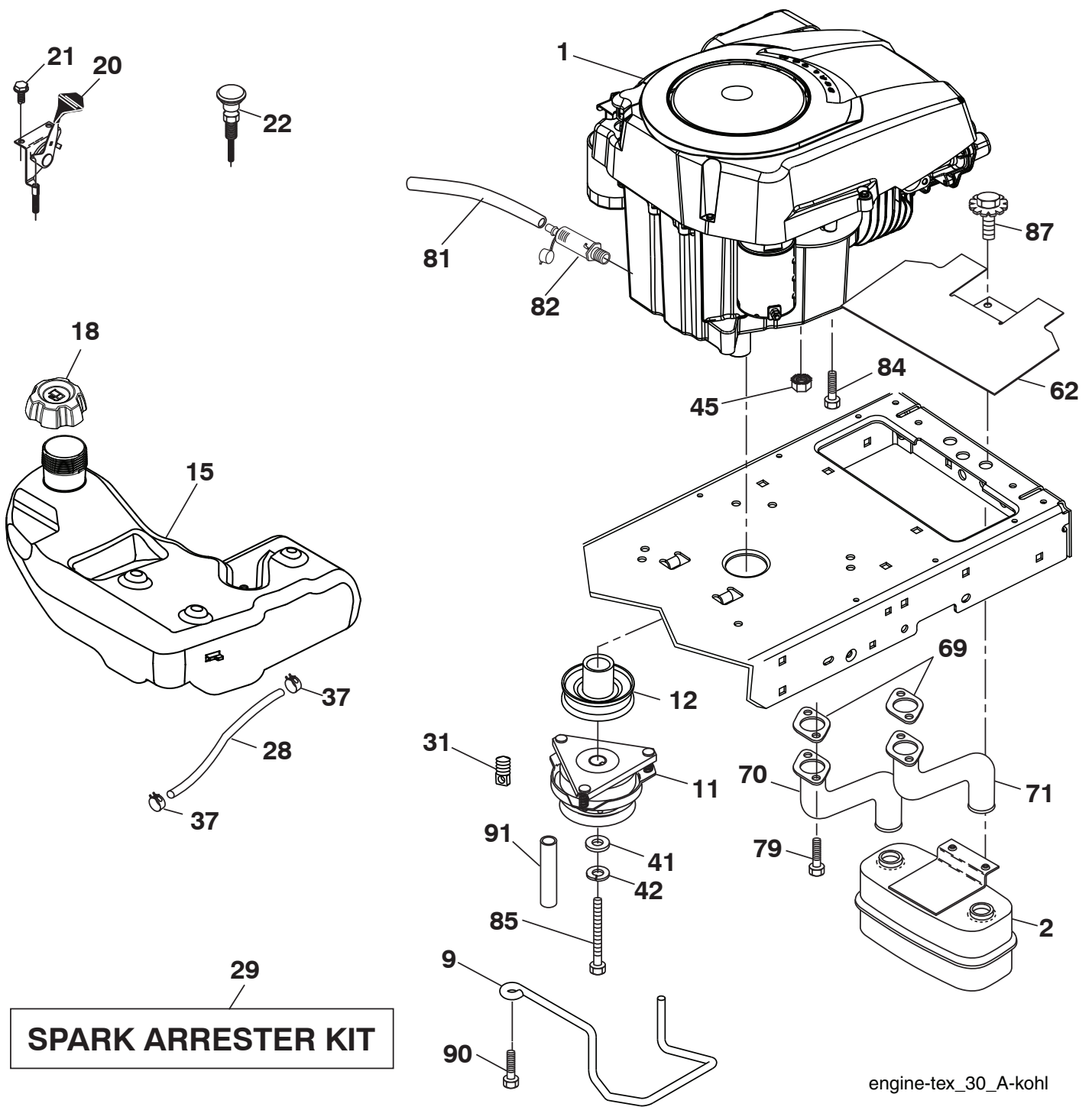

**TRACTOR -- MODEL NO. YTH200 TWIN (96041006300), PRODUCT NO. 960 41 00-63
ENGINE 24**

KEY PART NO. NO.	DESCRIPTION
1 - - - - -	Engine KOHL Model No. SV710
2 532 14 97-23	Muffler
9 532 19 43-20	Keeper Belt Engine
11 532 40 00-08	Clutch Electric
12 532 40 50-97	Pulley Engine
15 532 19 34-99	Tank Fuel 4.0
18 532 19 42-67	Cap Asm.
20 532 18 29-37	Control Throttle
21 532 19 16-11	Screw 10 x 3/4 Single Lead Hex
22 532 19 15-96	Control Choke
28 532 14 21-58	Fuel Line
29 532 13 71-80	Spark Arrester Kit
31 532 14 50-06	Clip Push-In
37 532 12 34-87	Clamp Hose
41 532 12 61-97	Washer 1-1/2 OD x 15/32 ID x .250
42 810 04 07-00	Washer Lock 7/16
45 873 51 04-00	Nut Keps Hex 1/4-20 unc
62 532 14 66-29	Shield Heat Muffler
69 532 18 60-54	Gasket
70 532 14 66-99	Tube Exhaust LH
71 532 14 67-00	Tube Exhaust RH
79 532 19 23-34	Screw Socket Head 5/16-18 x .75
81 532 14 84-56	Tube Drain Oil Easy
82 532 18 16-54	Plug Drain Oil
84 817 12 06-16	Screw 3/8-16 x 1
85 532 17 39-37	Bolt Hex 7/16-20 x 4-5 Ga.
87 532 17 18-77	Bolt 5/16-18 unc x 1 w/Sems.
90 817 00 06-16	Screw 3/8-16 x 1
91 532 18 74-95	Bushing

NOTE: All component dimensions given in U.S. inches
1 inch = 25.4 mm

TRACTOR -- MODEL NO. YTH200 TWIN (96041006300), PRODUCT NO. 960 41 00-63
STEERING ASSEMBLY **41**

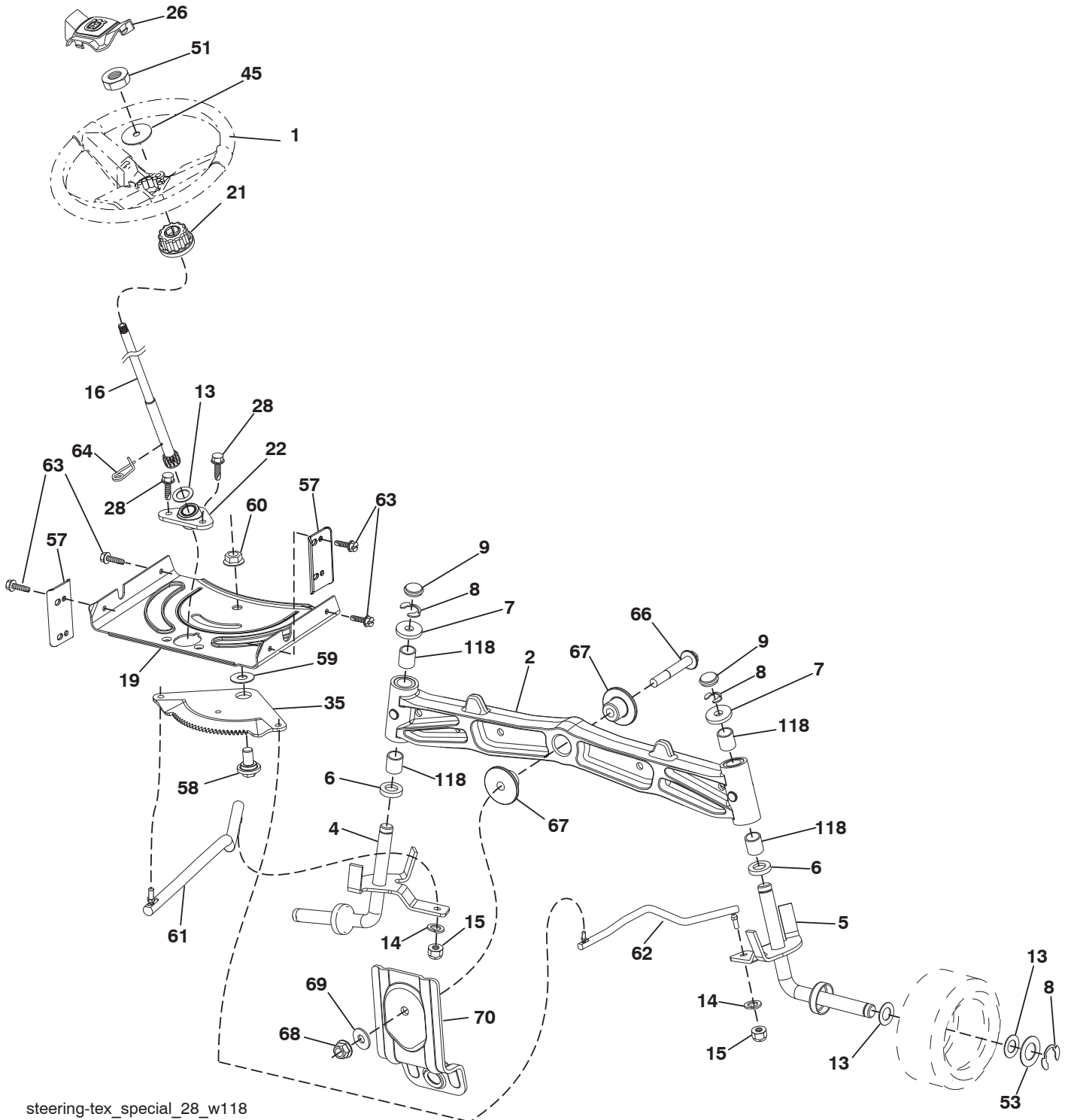

steering-tex_special_28_w118

**TRACTOR -- MODEL NO. YTH200 TWIN (96041006300), PRODUCT NO. 960 41 00-63
STEERING ASSEMBLY **41****

KEY NO.	PART NO.	DESCRIPTION
1	532 41 64-80	Wheel, Steering Husq SR
2	532 18 47-06	Axle Asm., Front
4	532 40 30-87	Spindle Asm., LH
5	532 40 30-88	Spindle Asm., RH
6	532 12 49-31	Bearing, Race Thrust Harden
7	532 12 17-48	Washer 25/32 x 1-5/8 x 16 Ga.
8	812 00 00-29	Ring, Clip #T5304-75
9	532 12 12-32	Cap, Spindle
13	532 12 17-49	Washer 25/32 x 1-1/4 x 16 Ga.
14	810 04 06-00	Washer, Lock Hvy. Hlcl. Spr. 3/8
15	873 54 06-00	Nut, Crown Lock 3/8-24 unf
16	532 19 47-46	Shaft Steering
19	532 19 47-29	Plate Steering
21	532 18 67-37	Adapter, Wheel Steering
22	532 19 48-45	Bushing, Strg. Blk.
26	532 41 59-87	Insert, Wheel Steering Husq SR
28	817 00 06-12	Screw 3/8-16 x 3/4
35	532 19 47-32	Gear, Sector Plate
45	819 18 38-12	Washer 9/16 x 2-3/8 x 12 Ga.
51	873 94 08-00	Nut Hex Jam Toplock 1/2-20 unf
53	532 18 89-67	Washer Hardened .793 x 1.637 x .060
57	532 40 74-65	Bracket Upstop
58	532 19 47-47	Bolt Shoulder Sector Pivot CFM
59	532 19 47-48	Washer Thrust Sector Steering
60	873 97 10-00	Nut Flange Lock 5/8-11
61	532 19 47-40	Draglink, LH
62	532 19 47-41	Draglink, RH
63	817 00 05-12	Screw 5/16-18 x 3/4
64	532 19 98-49	Retainer Clip Spring Steering
66	871 02 07-48	Bolt Hex Fghd. 7/16-14 x 3 Serr.
67	532 19 47-37	Bushing PM Front Axle
68	873 90 07-00	Nut Lock Flange 7/16-14 Gr. 5
69	532 19 91-62	Washer 1.5 x .505 x .118
70	532 19 61-97	Bracket Deck Susp. Front
79	532 40 44-84	Decal Steering
118	532 40 60-13	Bushing Metal, Axle, Cast

NOTE: All component dimensions given in U.S. inches
1 inch = 25.4 mm

TRACTOR -- MODEL NO. YTH200 TWIN (96041006300), PRODUCT NO. 960 41 00-63
MOWER DECK 44

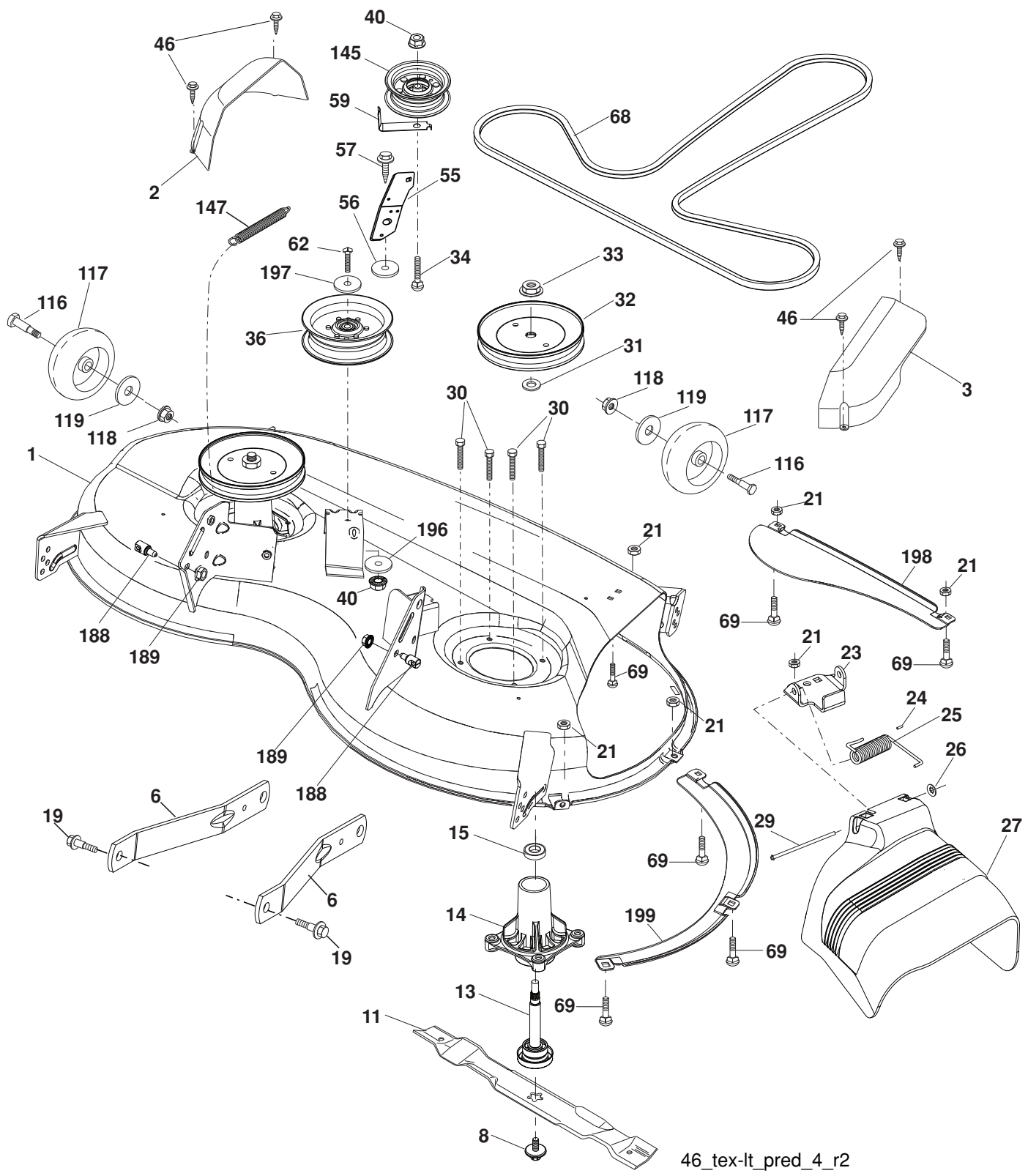

46_tex-lt_pred_4_r2

**TRACTOR -- MODEL NO. YTH200 TWIN (96041006300), PRODUCT NO. 960 41 00-63
MOWER DECK 44**

KEY NO.	PART NO.	DESCRIPTION	KEY NO.	PART NO.	DESCRIPTION
1	532 40 50-50	Mower Housing	57	817 00 06-16	Screw Hex Wsh. Thd. 3/8-16 x 1
2	532 40 55-07	Cover Mandrel LH	59	532 14 10-43	Guard, Tuv. Idler (94)
3	532 40 55-06	Cover Mandrel RH	68	532 40 51-43	V-Belt
6	532 19 51-86	Arm Suspension	69	872 14 05-05	Bolt
8	532 19 30-03	Bolt/Washer Asm. 7/16-20 unf	116	532 12 48-42	Bolt, Shoulder
11	532 40 53-80	Blade Mower	117	532 18 86-06	Wheel, Gauge
13	532 19 28-72	Shaft Assembly, Mandrel	118	873 93 06-00	Nut Lock Flg. 3/8-16 unc
14	532 18 72-81	Housing, Mandrel	119	819 12 14-14	Washer 3/8 x 7/8
15	532 11 04-85	Bearing, Ball, Mandrel	129	819 13 13-12	Washer 13/32 x 13/16 x 12 Ga.
19	532 19 65-39	Bolt, Shoulder	145	532 19 73-79	Pulley Idler
21	873 68 05-00	Nut	147	532 19 72-51	Spring
23	532 19 25-57	Bracket, Deflector	188	532 19 51-61	Stud Fastener
24	532 10 53-04	Cap, Sleeve	189	873 90 05-00	Nut Lock Hex Flange
25	532 19 70-26	Spring, Torsion, Deflector	196	532 41 35-24	Washer 13/32 x 1 x 1/2
26	532 11 04-52	Nut, Push	198	532 40 31-49	Baffle Center Front
27	532 40 53-57	Shield, Deflector	199	532 40 31-50	Baffle Front RH
29	532 13 14-91	Rod, Hinge	240	874 52 06-36	Bolt 3/8-16 x 2-1/4 Gr. 5
30	532 17 39-84	Screw Thdrol. Rolling Wsh. Hd.	--	532 19 28-70	Mandrel Assembly (Includes housing, shaft assembly, and bearing only - pulley/nut/washer and blade bolt/washers not included)
31	532 18 76-90	Washer, Spacer			
32	532 19 74-73	Pulley, Mandrel			
33	532 40 02-34	Nut, Toplock, Flanged			
34	872 11 06-12	Bolt Carr. Sh. 3/8-16 x 1-1/2 Gr. 5			
36	532 19 31-97	Pulley, Idler, Flat	--	532 41 60-70	Replacement Mower, Complete
40	873 90 06-00	Nut 3/8-16 unc			
46	532 13 77-29	Screw			
55	532 19 72-49	Arm, Idler			
56	532 19 90-92	Spacer, Retainer			

NOTE: All component dimensions given in U.S. inches
1 inch = 25.4 mm

TRACTOR -- MODEL NO. YTH200 TWIN (96041006300), PRODUCT NO. 960 41 00-63
SEAT ASSEMBLY 42

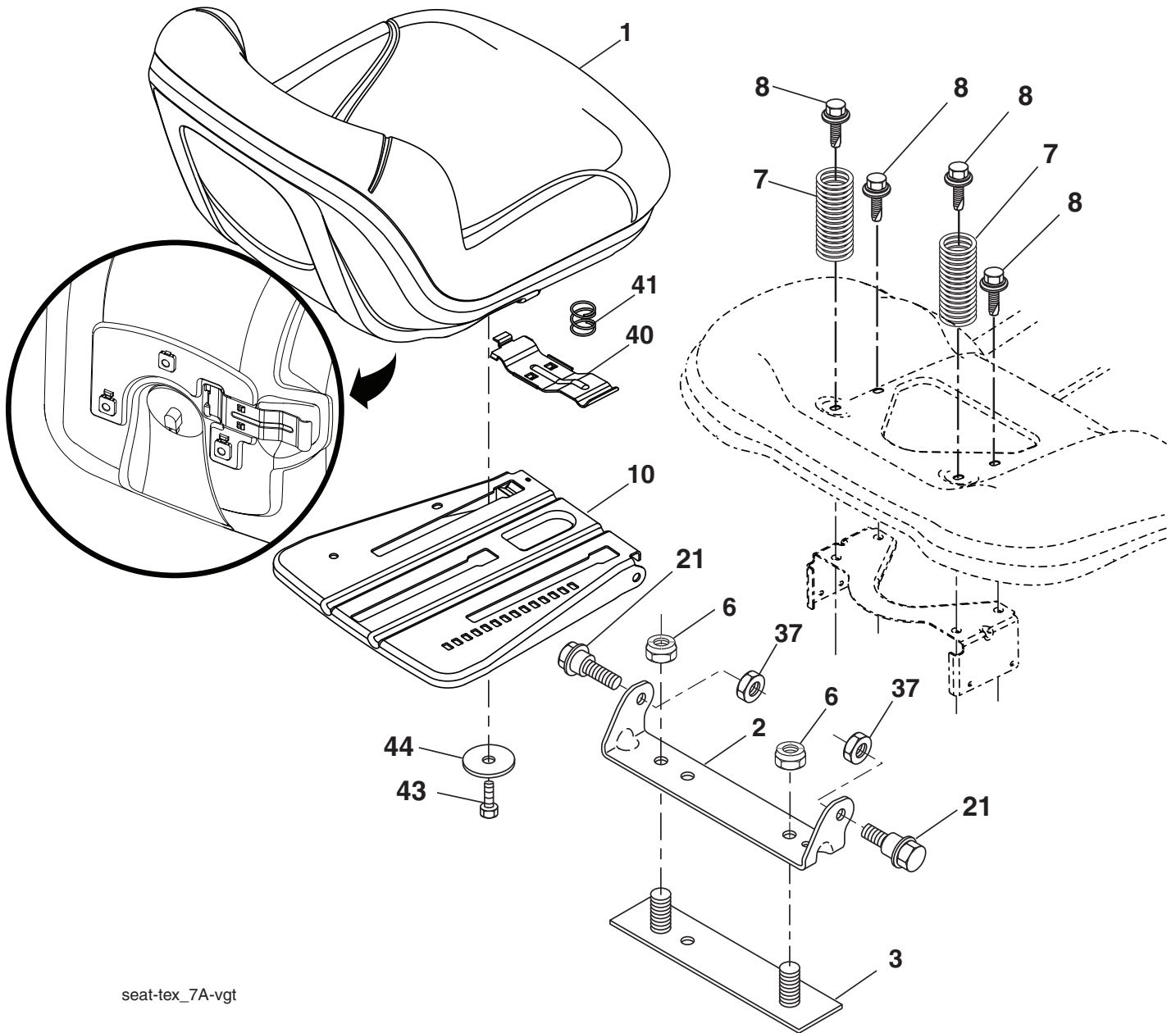

seat-tex_7A-vgt

KEY NO.	PART NO.	DESCRIPTION
1	532 40 66-21	Seat
2	532 18 01-66	Bracket Pivot Fender
3	532 14 06-75	Strap, Asm. Fender
6	873 80 06-00	Nut, Lock w/Ins. 3/8-16 unc
7	532 12 41-81	Spring, Seat Cprsn.
8	532 17 18-77	Bolt 5/16-18 unc x 3/4 w/Sems.
10	532 19 69-77	Pan, Seat
21	532 17 18-52	Bolt, Shoulder 5/16-18

KEY NO.	PART NO.	DESCRIPTION
37	873 80 05-00	Nut, Lock 5/16-18 unc
40	532 19 76-61	Handle Slide Seat
41	532 19 82-00	Spring Latch Seat
43	874 76 06-12	Bolt 3/8-16 x 3/4
44	819 13 38-12	Washer 13/32 x 2-3/8 x 12 Ga.

NOTE: All component dimensions given in U.S. inches
 1 inch = 25.4 mm

**TRACTOR -- MODEL NO. YTH200 TWIN (96041006300), PRODUCT NO. 960 41 00-63
MOWER LIFT 45**

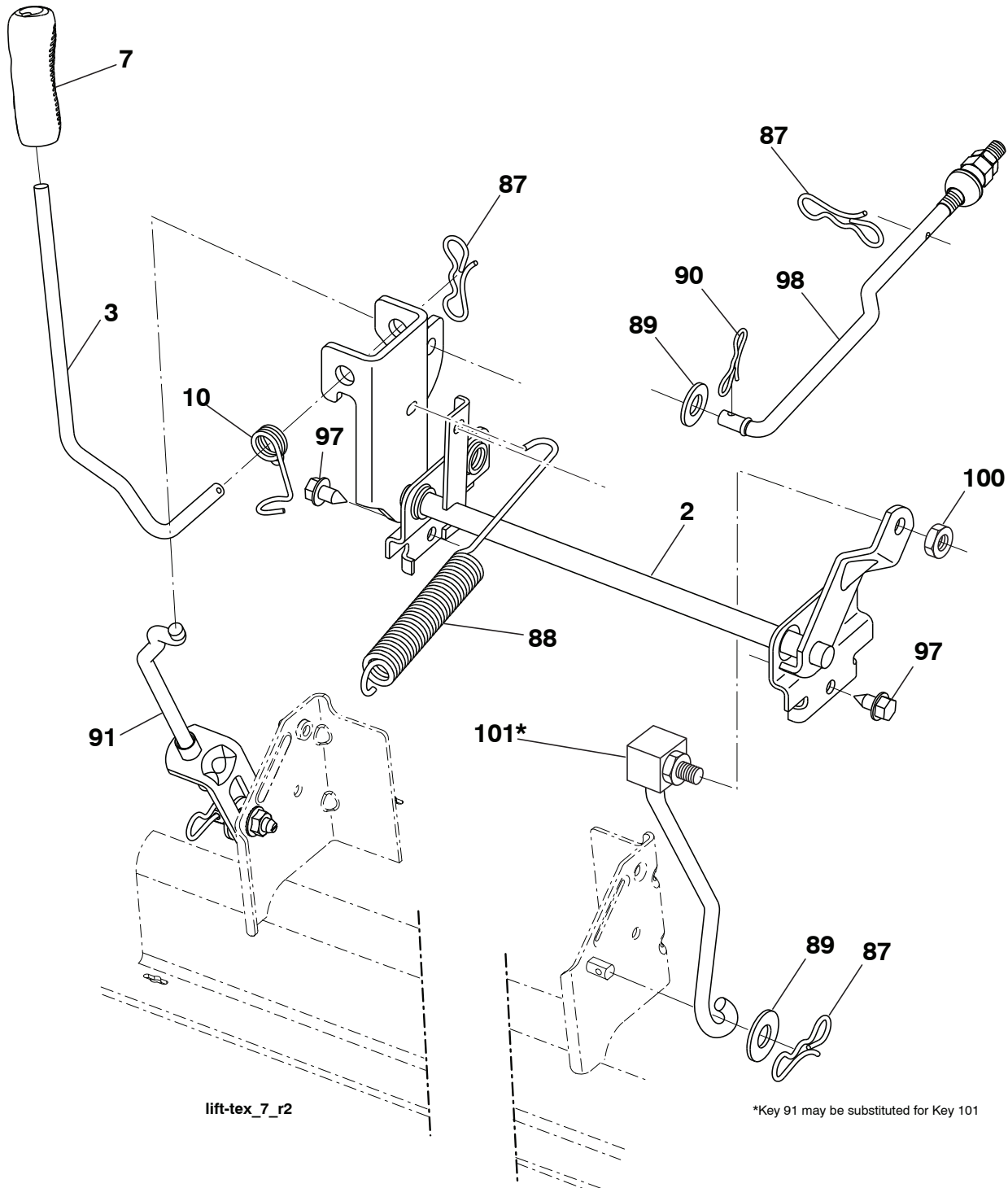

lift-tex_7_r2

*Key 91 may be substituted for Key 101

KEY NO.	PART NO.	DESCRIPTION
2	532 19 52-23	Shaft Asm., Lift
3	532 19 52-30	Lever Asm., Lift
7	532 41 15-55	Grip, Lever
10	532 19 63-14	Spring Torsion
87	532 19 42-09	Pin Cotter 7/16 Bow Tie Lock
88	532 41 07-10	Spring Lift Assist
89	819 19 19-12	Washer Clear Zinc
90	532 19 42-08	Pin Cotter 5/16 Bow Tie Lock

KEY NO.	PART NO.	DESCRIPTION
91	532 19 51-81	Link Lift Susp. Mower Rear
97	817 00 06-12	Screw 3/8-16 x .75 Smgml. Tap/R.Z
98	532 19 52-70	Link Lift Susp. Front Mower
100	873 93 06-00	Nut Centerlock 3/8-16 unc
101	532 40 70-03	Link asm Lift FXD

NOTE: All component dimensions given in U.S. inches
1 inch = 25.4 mm