



K3000 Electric

Reservdelar

Spare parts

Ersatzteile

Pieces de rechange

Piezas de repuesto

Ricambi

Peças sobresselente

No.	Pos.	Description	No.	Pos.	Description
501 69 17-02	G	COMBINATION TOOL	544 90 47-01	E	SHAFT
503 20 02-12	C	SCREW	544 98 40-01	D	LABEL WARNING
503 21 20-01	A	SCREW	723 22 85-81	D	SCREW
503 22 10-08	B	NUT	724 12 87-59	D	SCREW
503 25 09-01	B	BALL BEARING	724 12 91-01	D	SCREW
505 52 02-11	A	CABLE CPL 220V CL.1	724 13 27-55	A	SCREW
505 52 02-17	A	CABLE 110V	725 53 29-55	C	SCREW
505 53 03-07	D	AIR STREAM DIRECTOR	729 57 76-01	D	SCREW
505 53 03-10	C	GASKET	732 21 14-01	D	LOCK NUT
505 53 03-11	A	SCREW	734 11 36-01	D	WASHER
505 53 03-11	D	SCREW	735 11 36-50	D	WASHER
505 53 03-11	E	SCREW	735 11 46-50	AD	WASHER
505 53 03-14	B	RUBBER BUSHING	735 21 36-01	D	WASHER
505 53 03-16	B	SPACER	735 31 08-00	E	CIRCLIP
505 53 03-19	B	SPACER	735 31 33-10	B	CIRCLIP
505 53 03-41	B	FELT JOINT	738 22 00-15	C	BALL BEARING
505 53 03-51	B	SPRING WASHER	738 22 02-27	B	BALL BEARING
505 53 03-52	B	SPACER			
505 53 03-56	A	CABLE			
506 02 87-01	C	FLANGE WASHER			
506 02 88-30	C	BUSHING			
506 09 86-02	B	PINION			
506 09 86-02	C	PINION			
506 13 95-11	C	WASHER			
506 13 96-01	C	COLLAR SCREW			
506 15 00-02	F	WHEEL GUARD			
506 15 03-03	E	HANDLE			
506 22 50-10	B	ARMATURE			
506 22 50-20	B	ARMATURE			
506 22 51-10	D	FIELD COIL			
506 22 51-20	D	FIELD COIL			
506 22 53-01	D	SCREW			
506 22 58-02	D	CARBON BRUSH			
506 26 49-04	F	WHEEL GUARD			
506 26 63-02	C	LINING			
506 26 64-01	C	SCREEN PATTERN FLANG			
506 26 65-01	C	FLANGE			
506 28 84-01	C	SCREEN PATTERN FLANG			
506 30 42-01	C	SPACER			
506 32 06-01	C	SEALING			
506 37 96-20	C	BUSHING			
506 37 96-22	C	BUSHING			
506 37 96-25	C	BUSHING			
506 38 43-14	D	LABEL			
506 38 44-15	D	LABEL			
531 03 12-76	E	SCREW			
531 03 18-23	E	SPRING			
531 03 18-75	C	GEAR WHEEL			
531 03 18-76	A	PLUG			
531 03 18-81	A	ENGINE PROTECTION			
531 03 18-82	A	ENGINE PROTECTION			
531 03 18-83	A	SWITCH			
531 03 18-85	A	SPRING			
531 03 18-87	A	CLIP			
531 03 18-90	D	MOTOR HOUSING			
531 03 18-91	D	PIPE			
531 03 18-92	D	BRUSH ROCKER			
531 03 18-94	E	SCREW			
531 03 19-01	C	SCREW			
531 03 19-02	A	SCREW			
544 40 32-01	C	GEAR SET			
544 40 33-01	C	SHAFT			
544 40 34-01	E	GEAR HOUSING			
544 89 94-01	D	LID			
544 90 02-01	D	LID			
544 90 05-01	A	CABLE SLEEVE			
544 90 06-01	A	LOCKING BUTTON			
544 90 33-01	D	LABEL			
544 90 33-02	D	LABEL			
544 90 45-01	A	HANDLE ASSY			

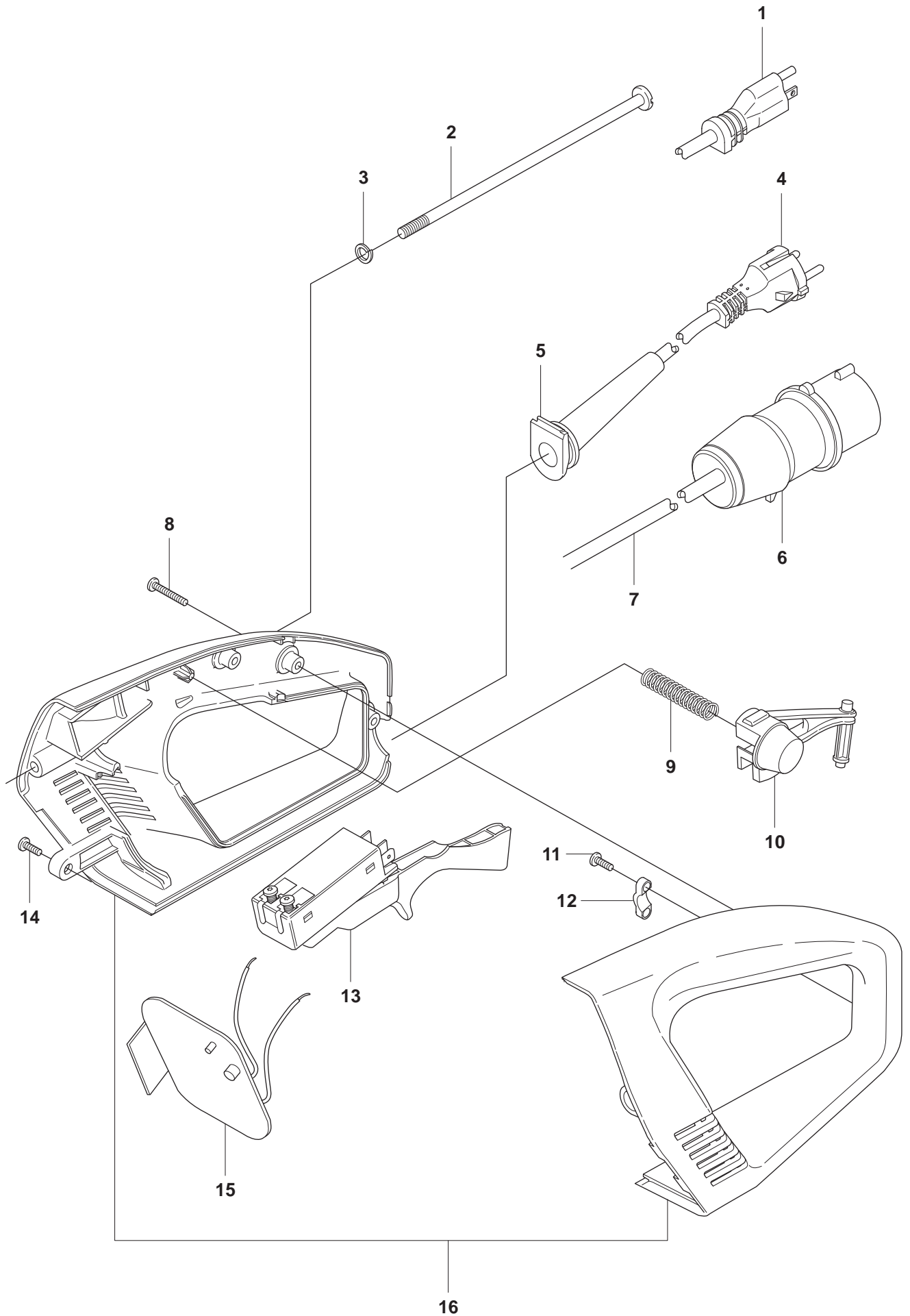
A**K3000 ELECTRIC**

Page A
K3000 Electric

Pos.	Part No.	Description	Quantity	Notes
1	505 53 03-56	CABLE	1	JP, USA
2	505 53 03-11	SCREW	1	
3	735 11 46-50	WASHER	1	
4	505 52 02-11	CABLE CPL 220V CL.1	1	230V
5	544 90 05-01	CABLE SLEEVE	1	230V
6	531 03 18-76	PLUG	1	110V
7	505 52 02-17	CABLE 110V	1	110V
8	531 03 19-02	SCREW	3	
9	531 03 18-85	SPRING	1	
10	544 90 06-01	LOCKING BUTTON	1	
11	503 21 20-01	SCREW	2	
12	531 03 18-87	CLIP	1	
13	531 03 18-83	SWITCH	1	
14	724 13 27-55	SCREW	1	
15	531 03 18-81	ENGINE PROTECTION	1	110V
15	531 03 18-82	ENGINE PROTECTION	1	230V
16	544 90 45-01	HANDLE ASSY	1	

B K3000 ELECTRIC

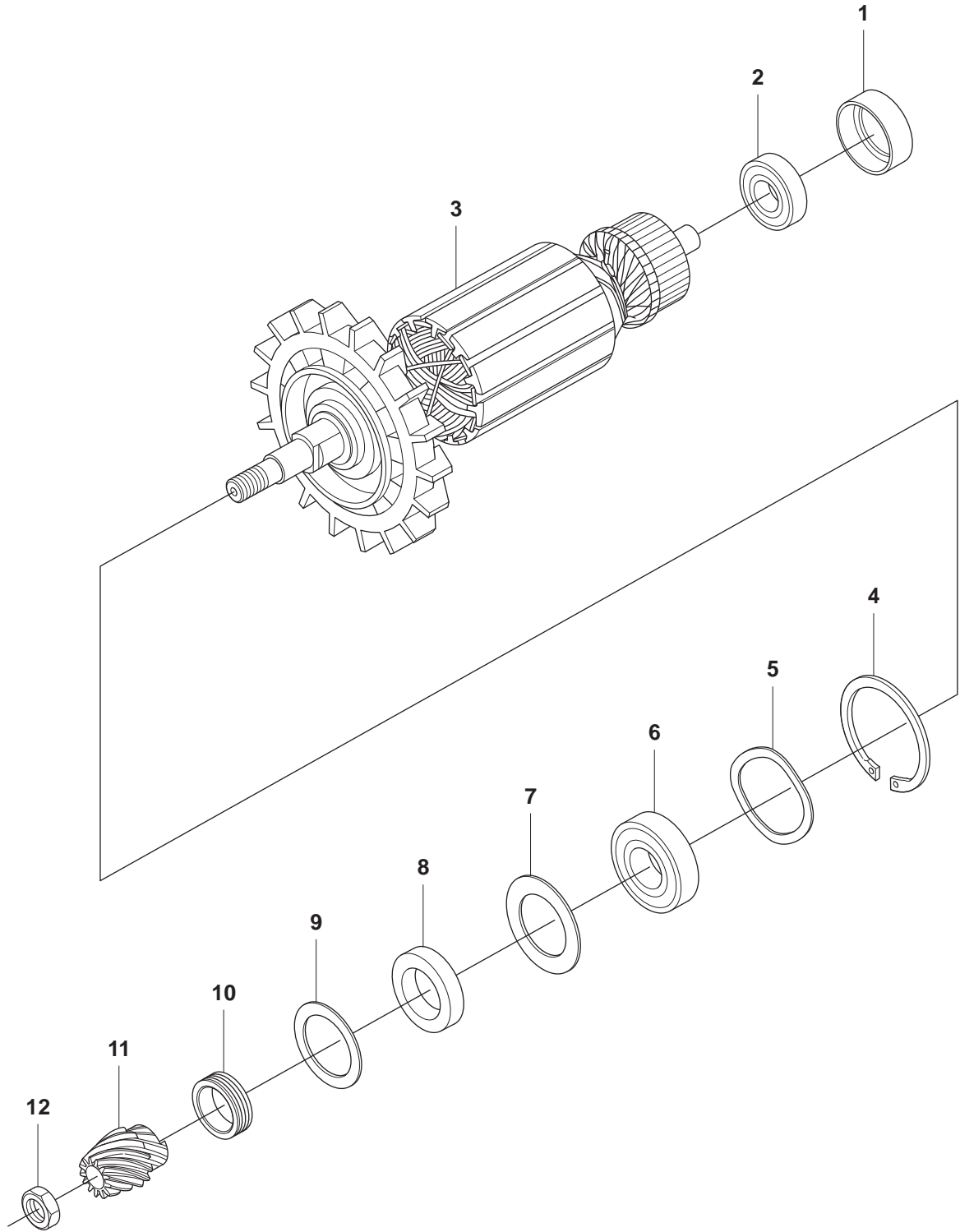

Page B
K3000 Electric

Pos.	Part No.	Description	Quantity	Notes
1	505 53 03-14	RUBBER BUSHING	1	
2	503 25 09-01	BALL BEARING	1	
3	506 22 50-10	ARMATURE	1	100 - 120V
3	506 22 50-20	ARMATURE	1	230V
4	735 31 33-10	CIRCLIP	1	
5	505 53 03-51	SPRING WASHER	1	
6	738 22 02-27	BALL BEARING	1	
7	505 53 03-16	SPACER	1	
8	505 53 03-41	FELT JOINT	1	
9	505 53 03-52	SPACER	1	
10	505 53 03-19	SPACER	1	
11	506 09 86-02	PINION	1	
12	503 22 10-08	NUT	1	

C K3000 ELECTRIC

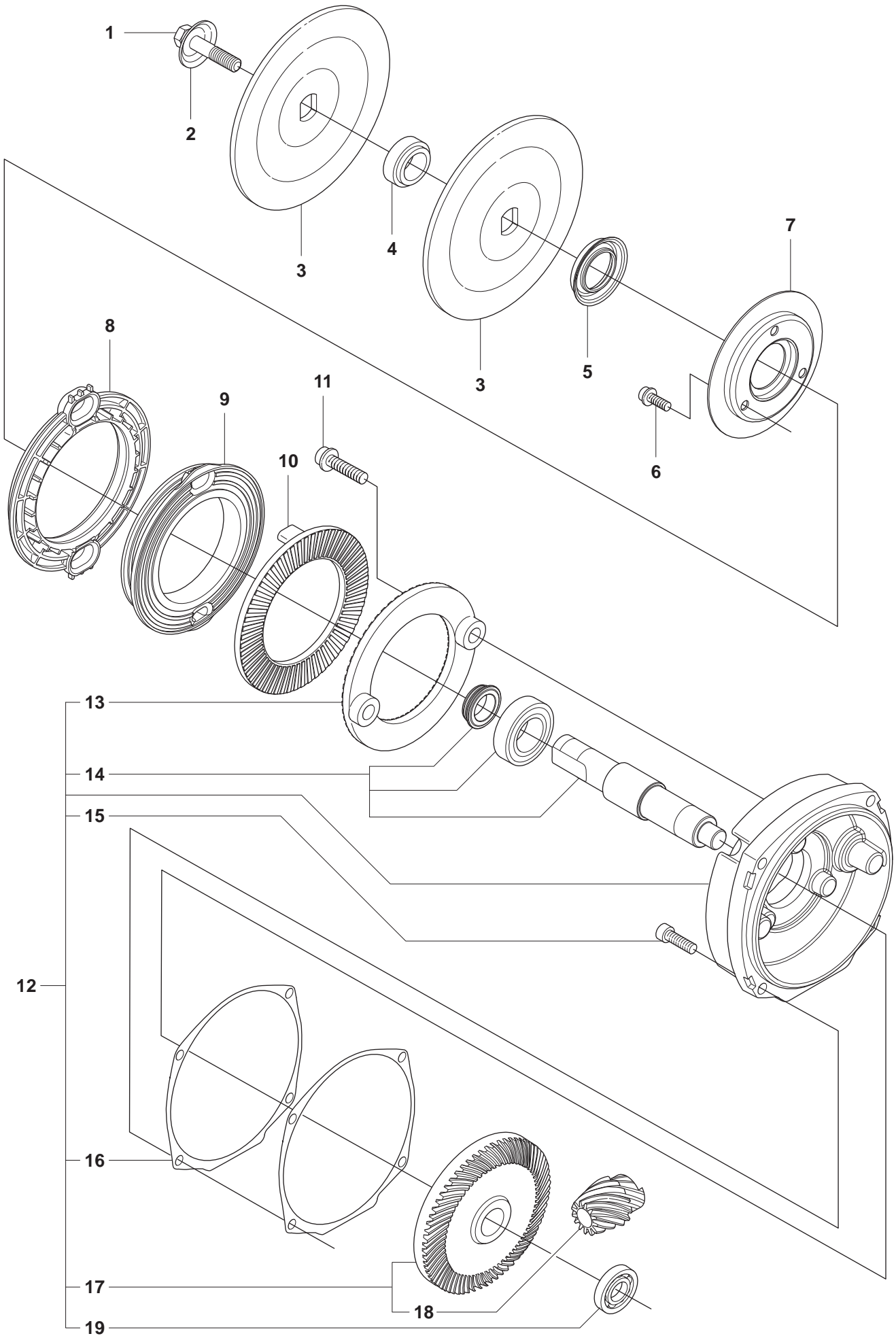

Page C
K3000 Electric

Pos.	Part No.	Description	Quantity	Notes
1	506 13 96-01	COLLAR SCREW	1	
2	506 13 95-11	WASHER	1	
3	506 02 87-01	FLANGE WASHER	2	
4	506 37 96-20	BUSHING	1	Diam 20mm
4	506 37 96-22	BUSHING	1	Diam 22,2mm
4	506 37 96-25	BUSHING	1	Diam 25,4mm
4	506 02 88-30	BUSHING	1	Diam 30,5mm
5	506 32 06-01	SEALING	1	
6	725 53 29-55	SCREW	3	
7	506 26 65-01	FLANGE	1	
8	506 30 42-01	SPACER	1	12" only
9	506 26 63-02	LINING	1	
10	506 26 64-01	SCREEN PATTERN FLANG	1	
11	503 20 02-12	SCREW	2	
12	544 40 32-01	GEAR SET	1	Incl. 13, 14, 15, 16, 17, 19
13	506 28 84-01	SCREEN PATTERN FLANG	1	
14	544 40 33-01	SHAFT	1	
15	531 03 19-01	SCREW	4	
16	505 53 03-10	GASKET	2	
17	531 03 18-75	GEAR WHEEL	1	Incl. 18
18	506 09 86-02	PINION	1	
19	738 22 00-15	BALL BEARING	1	

D K3000 ELECTRIC

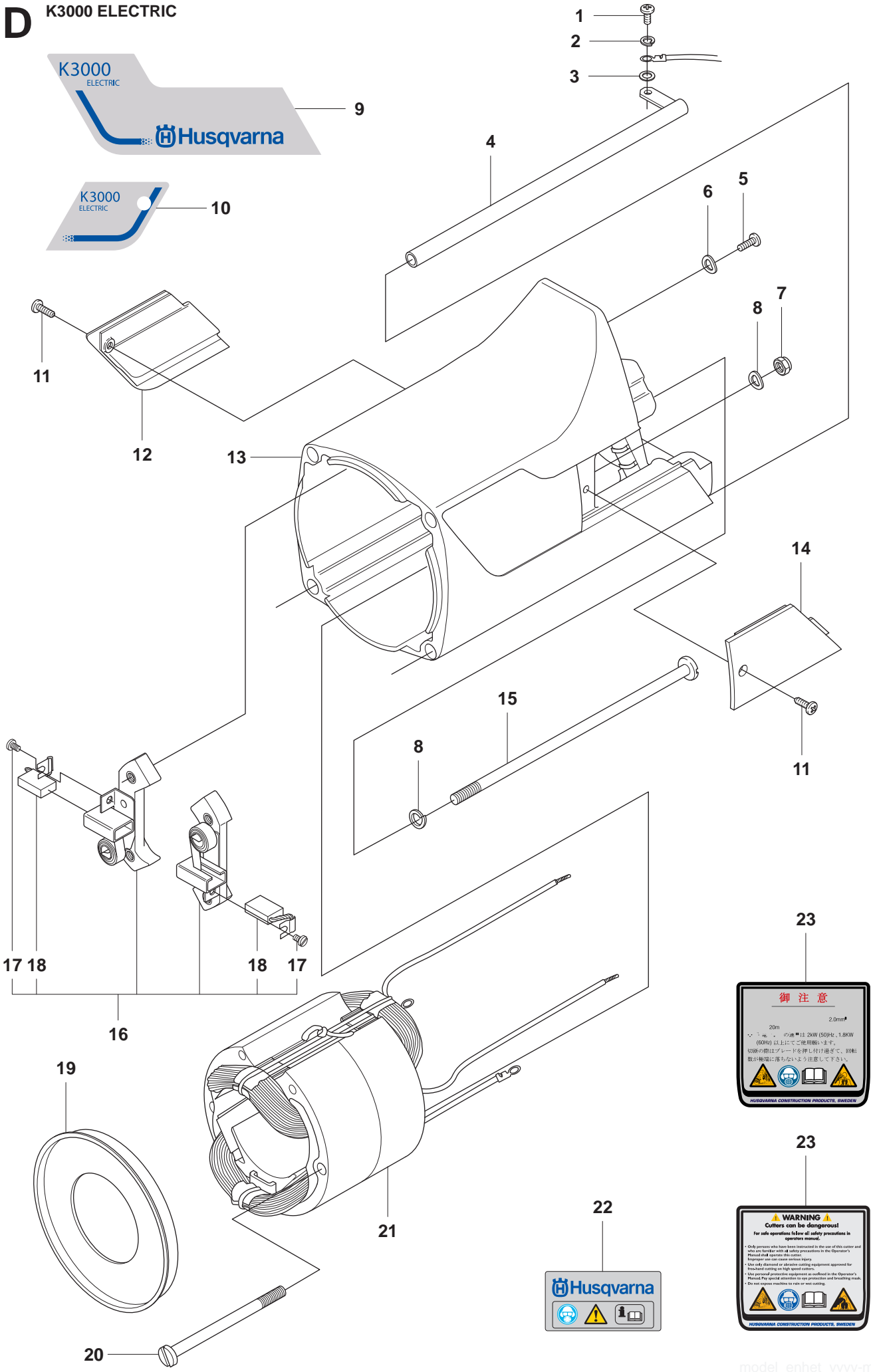

御注意

2.0m/s²

20m

この機器は 2kW (50Hz, 1.8kW (60Hz)) 以上にてご使用願います。

切株の際はブレードを押し付け過ぎて、刃先が地面に当たらないよう注意して下さい。

HUSQVARNA CONSTRUCTION PRODUCTS, SWEDEN

WARNING

Cutters can be dangerous!

For safe operations follow all safety precautions in operator manual.

- Only persons who have been instructed in the use of this cutter and who can handle with all safety precautions in the Operator's Manual should operate this cutting device.
- Responsible and safe use is required.
- Use only diamond or abrasive cutting equipment approved for Recycled cutting on high speed cutters.
- Use personal protective equipment as outlined in the Operator's Manual. Pay special attention to eye protection and hearing aids.
- Do not expose machines to rain or wet cutting.

HUSQVARNA CONSTRUCTION PRODUCTS, SWEDEN



Page D
K3000 Electric

Pos.	Part No.	Description	Quantity	Notes
1	724 12 87-59	SCREW	1	
2	735 21 36-01	WASHER	1	
3	734 11 36-01	WASHER	1	
4	531 03 18-91	PIPE	1	
5	724 12 91-01	SCREW	4	
6	735 11 36-50	WASHER	4	
7	732 21 14-01	LOCK NUT	2	
8	735 11 46-50	WASHER	2	
9	544 90 33-01	LABEL	1	
10	544 90 33-02	LABEL	1	
11	729 57 76-01	SCREW	1	
12	544 90 02-01	LID	1	
13	531 03 18-90	MOTOR HOUSING	1	
14	544 89 94-01	LID	1	
15	505 53 03-11	SCREW	1	
16	531 03 18-92	BRUSH ROCKER	1	Incl. 17, 18
17	506 22 58-02	CARBON BRUSH	2	
18	723 22 85-81	SCREW	2	
19	505 53 03-07	AIR STREAM DIRECTOR	1	
20	506 22 53-01	SCREW	2	
21	506 22 51-10	FIELD COIL	1	100 - 120V
21	506 22 51-20	FIELD COIL	1	230V
22	544 98 40-01	LABEL WARNING	1	
23	506 38 44-15	LABEL	1	JP
23	506 38 43-14	LABEL	1	USA

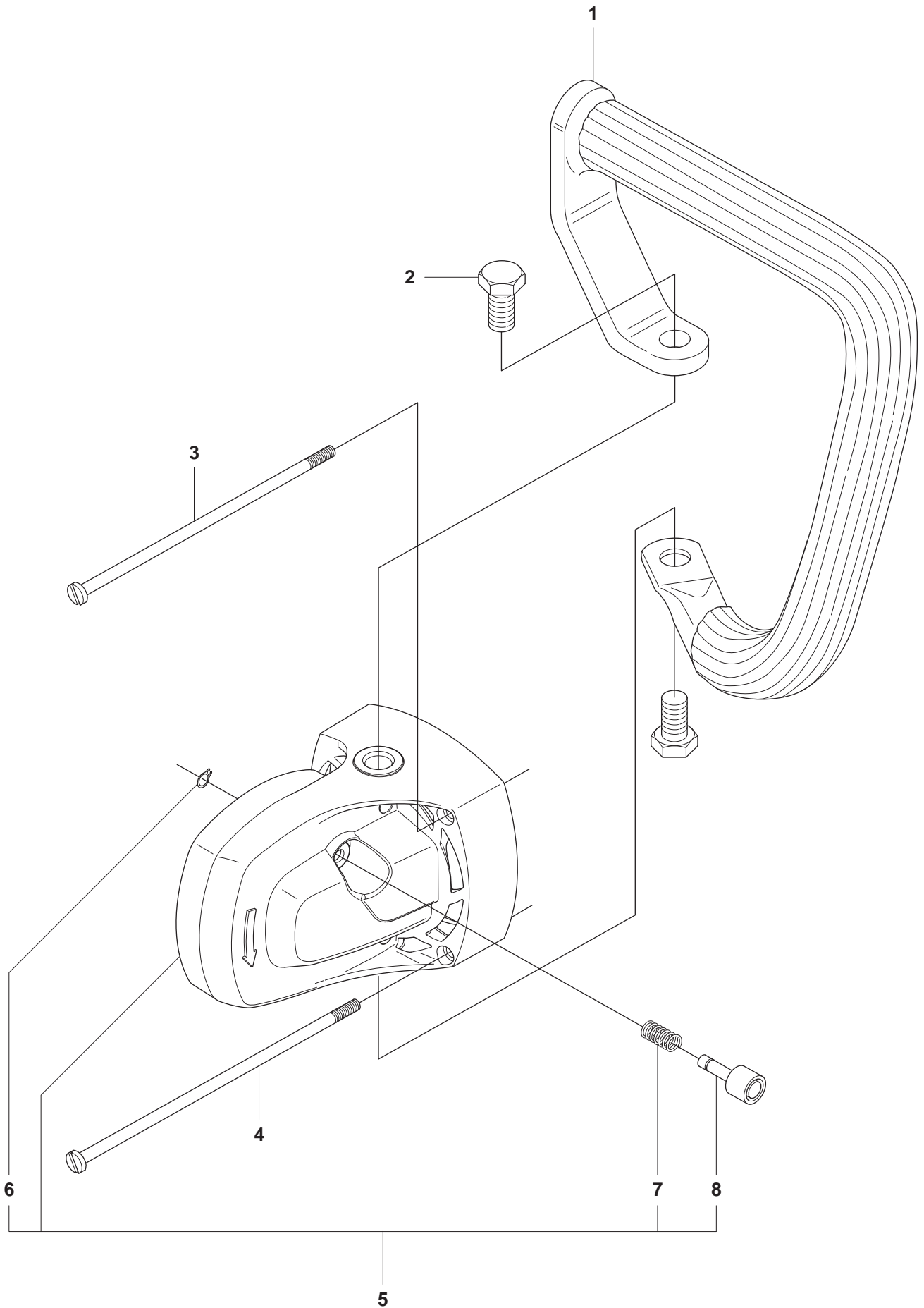
E**K3000 ELECTRIC**

Page E
K3000 Electric

Pos.	Part No.	Description	Quantity	Notes
1	506 15 03-03	HANDLE	1	
2	531 03 12-76	SCREW	2	
3	505 53 03-11	SCREW	1	
4	531 03 18-94	SCREW	1	
5	544 40 34-01	GEAR HOUSING	1	Incl. 6, 7, 8
6	735 31 08-00	CIRCLIP	1	
7	531 03 18-23	SPRING	1	
8	544 90 47-01	SHAFT	1	

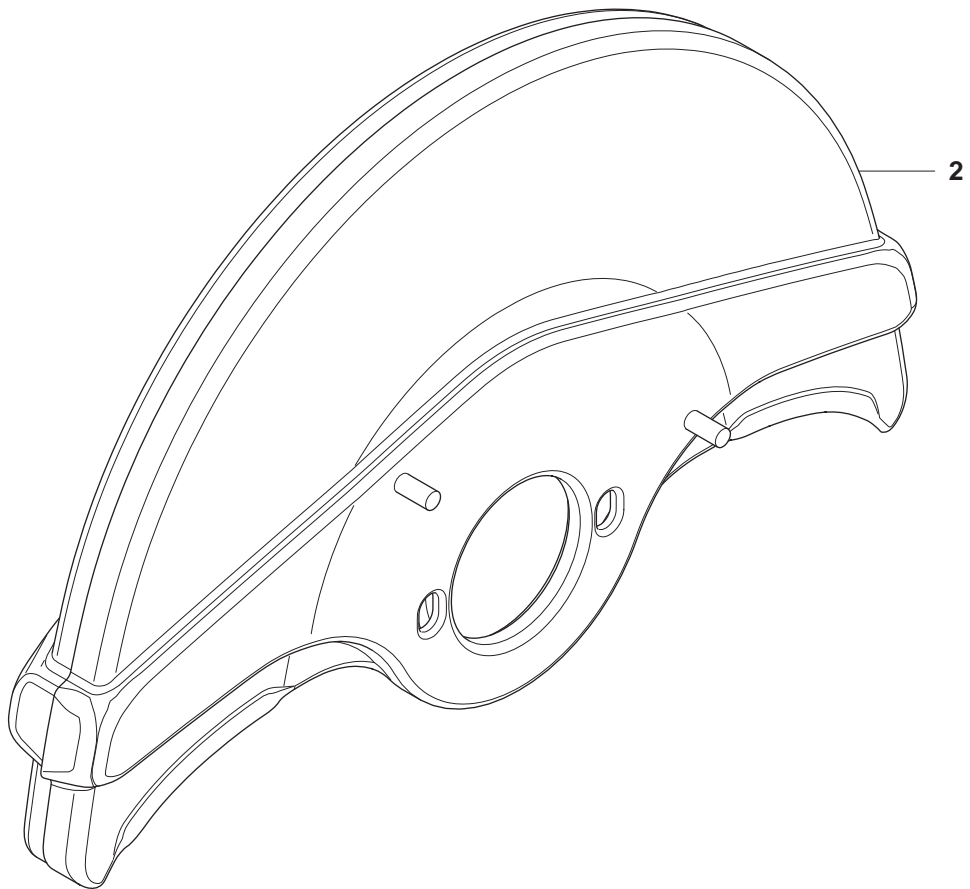
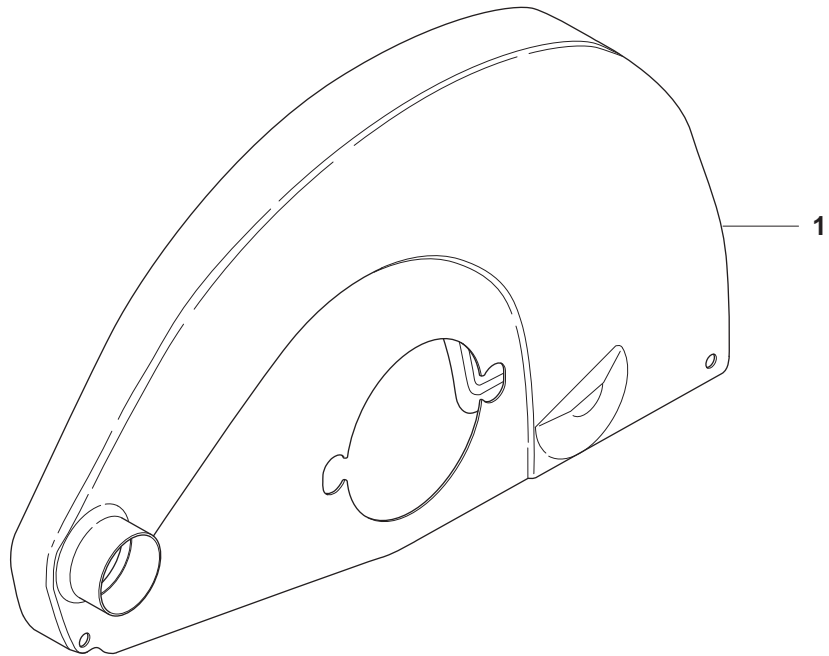

Page F
K3000 Electric

Pos.	Part No.	Description	Quantity	Notes
1	506 15 00-02	WHEEL GUARD	1	12"
2	506 26 49-04	WHEEL GUARD	1	14"

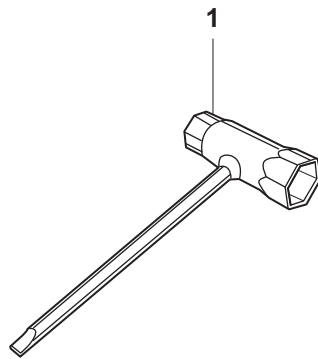

Page G
K3000 Electric

Pos.	Part No.	Description	Quantity	Notes
1	501 69 17-02	COMBINATION TOOL	1	