

LT151

Spare parts

Ersatzteile

Pièces détachées

Reserve onderdelen

Repuestos

Reservdelar

ILLUSTRATED PARTS LIST

MODEL NO. 96041001700
CUSTOMER CATALOG NO. LT151
PRODUCT NO. 960 41 00-17

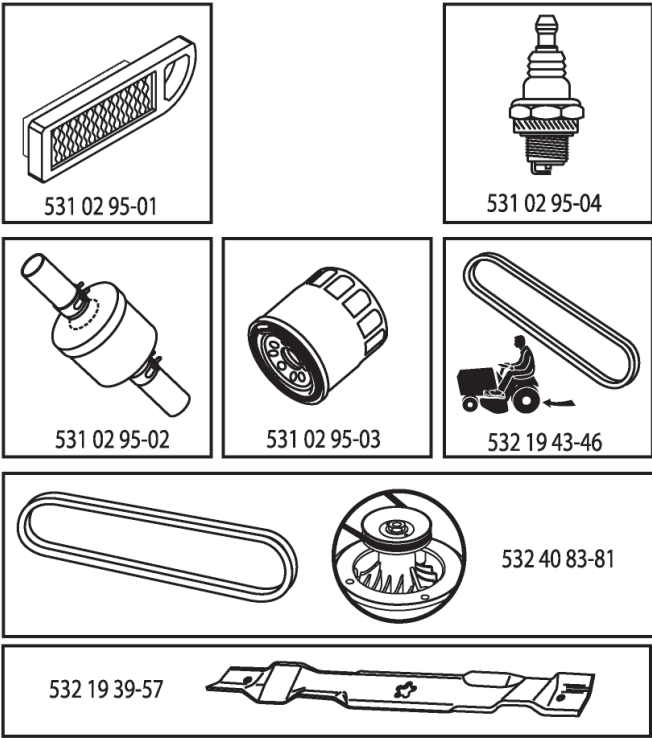

**TRACTOR - - MODEL NUMBER LT151 (96041001700), PRODUCT NO. 960 41 00-17
DECALS 27**

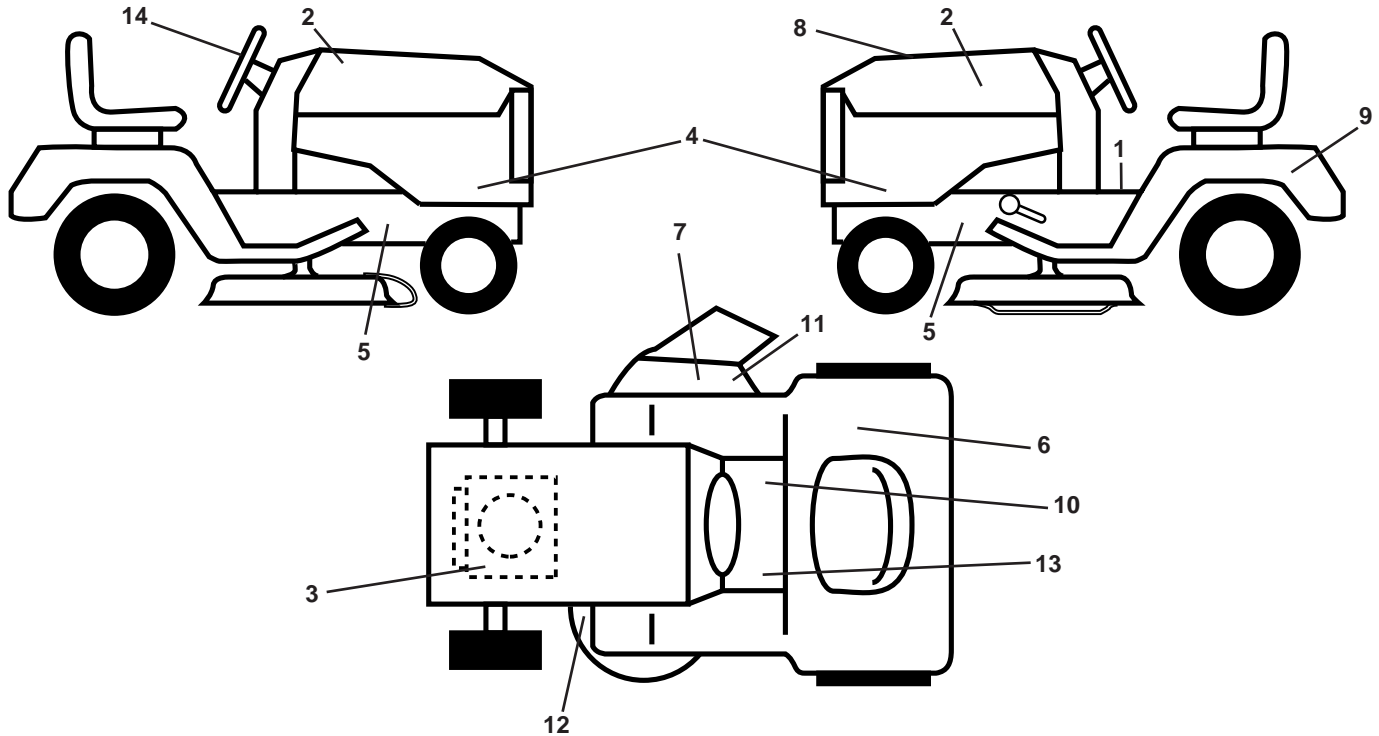

KEY NO.	PART NO.	DESCRIPTION
1	532 40 03-89	Decal, Operators
2	532 40 28-32	Decal, Hood
3	532 19 68-41	Decal, Warning Eng. Symbols
4	532 40 85-96	Decal, Hood Panel
5	532 15 97-36	Decal, Chassis Hot Muffler
6	532 18 04-32	Decal, Fender 100 DB/CE
7	532 18 21-66	Decal, Cutfinger CE
8	532 40 87-71	Decal, Rpl Kohl 15
9	532 14 50-05	Decal, Battery Dnge/Poi
10	532 14 08-37	Decal, Saddle Brake Parking

KEY NO.	PART NO.	DESCRIPTION
11	532 19 63-57	Decal, Warning
12	532 19 43-02	Decal, Mower V-Belt Schematic
13	532 15 97-37	Decal, Brake/Clutch Symbol
14	532 40 44-84	Decal, Steering Wheel
--	532 41 08-05	Pad, Footrest, LH
--	532 41 10-56	Pad, Footrest, RH
--	532 16 25-98	Decal, Drawbar Load Limit
--	532 40 78-08	Manual Oper. Euro
--	532 40 78-09	Manual Oper. Scand
--	532 40 78-10	Manual Oper. E-Bloc
--	532 40 78-11	Manual Oper. Baltic

WHEELS AND TIRES

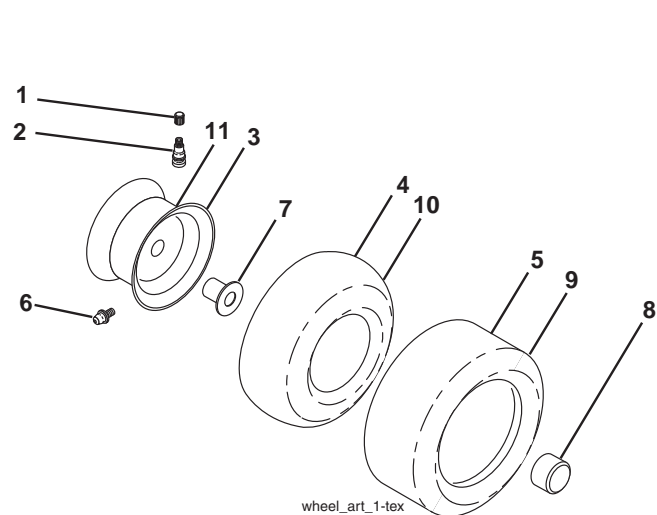

KEY NO.	PART NO.	DESCRIPTION
1	532 05 91-92	Cap Valve Tire
2	532 06 51-39	Stem Valve
3	532 13 83-36	Rim Asm 6" front Service
4	532 05 99-04	Tube Front (Service Item Only)
5	532 10 62-22	Tire F T 15 x 6 0 - 6 Service
6	532 12 49-57	Fitting Grease (Front Wheel Only)
7	532 12 49-59	Bearing Flange (Front Wheel Only)
8	532 17 50-39	Cap Axle Blk 1 50 x 1 00
9	532 10 62-68	Tire R T 18 x 9.5-8 Service
10	532 12 49-26	Tube Rear (Service Item Only)
11	532 13 83-37	Rim Asm 8" rear Service
--	532 14 43-34	Sealant, Tire (10 oz. Tube)

NOTE: All component dimensions given in U.S. inches
1 inch = 25.4 mm

TRACTOR - - MODEL NUMBER LT151 (96041001700), PRODUCT NO. 960 41 00-17

SCHEMATIC **38**

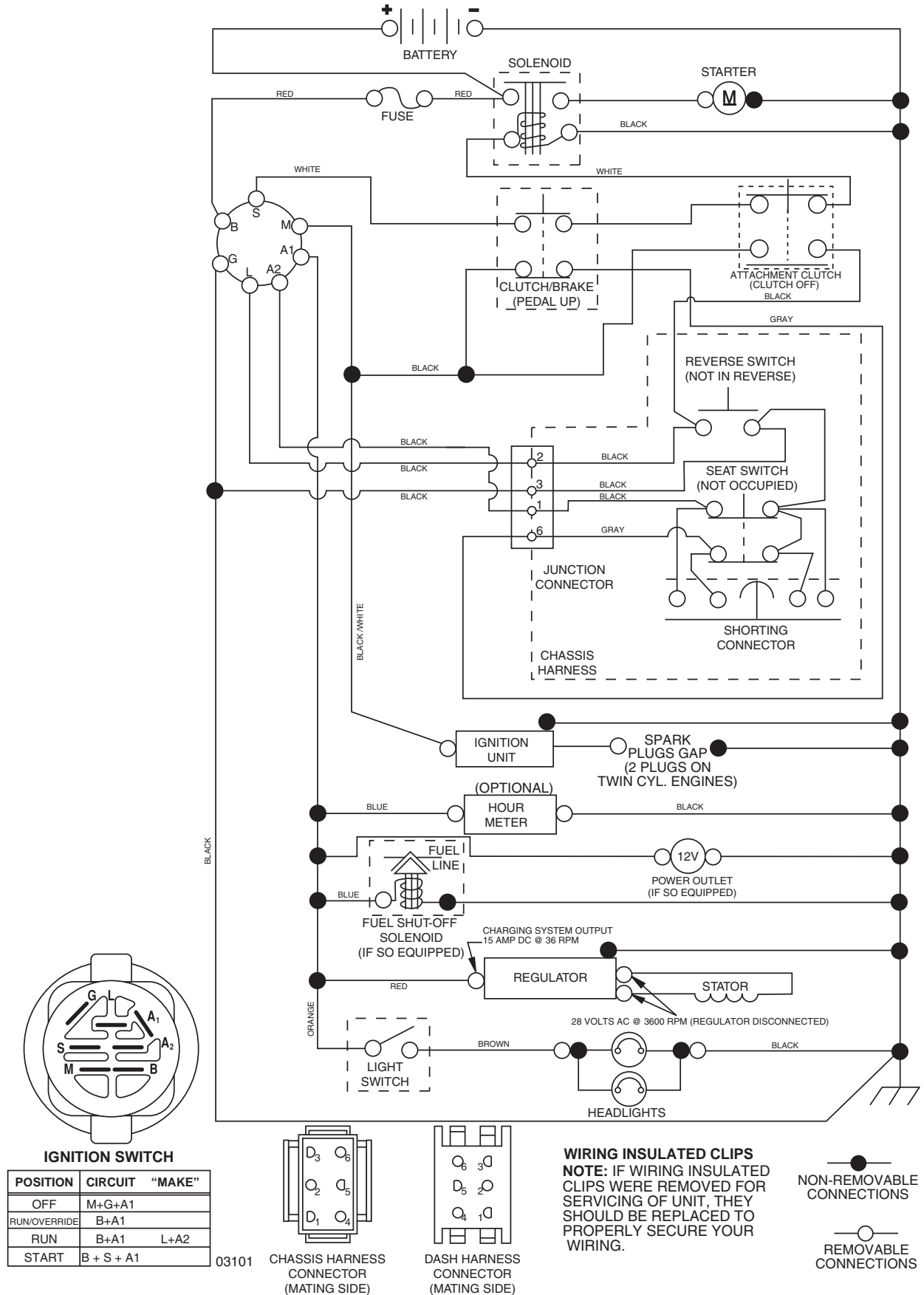

IGNITION SWITCH

POSITION	CIRCUIT	"MAKE"
OFF	M+G+A1	
RUN/OVERRIDE	B+A1	
RUN	B+A1	L+A2
START	B + S + A1	

03101

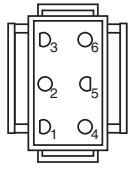

CHASSIS HARNESS CONNECTOR (MATING SIDE)

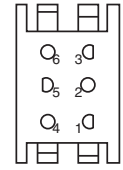

DASH HARNESS CONNECTOR (MATING SIDE)

TRACTOR - - MODEL NUMBER LT151 (96041001700), PRODUCT NO. 960 41 00-17
ELECTRICAL **32**

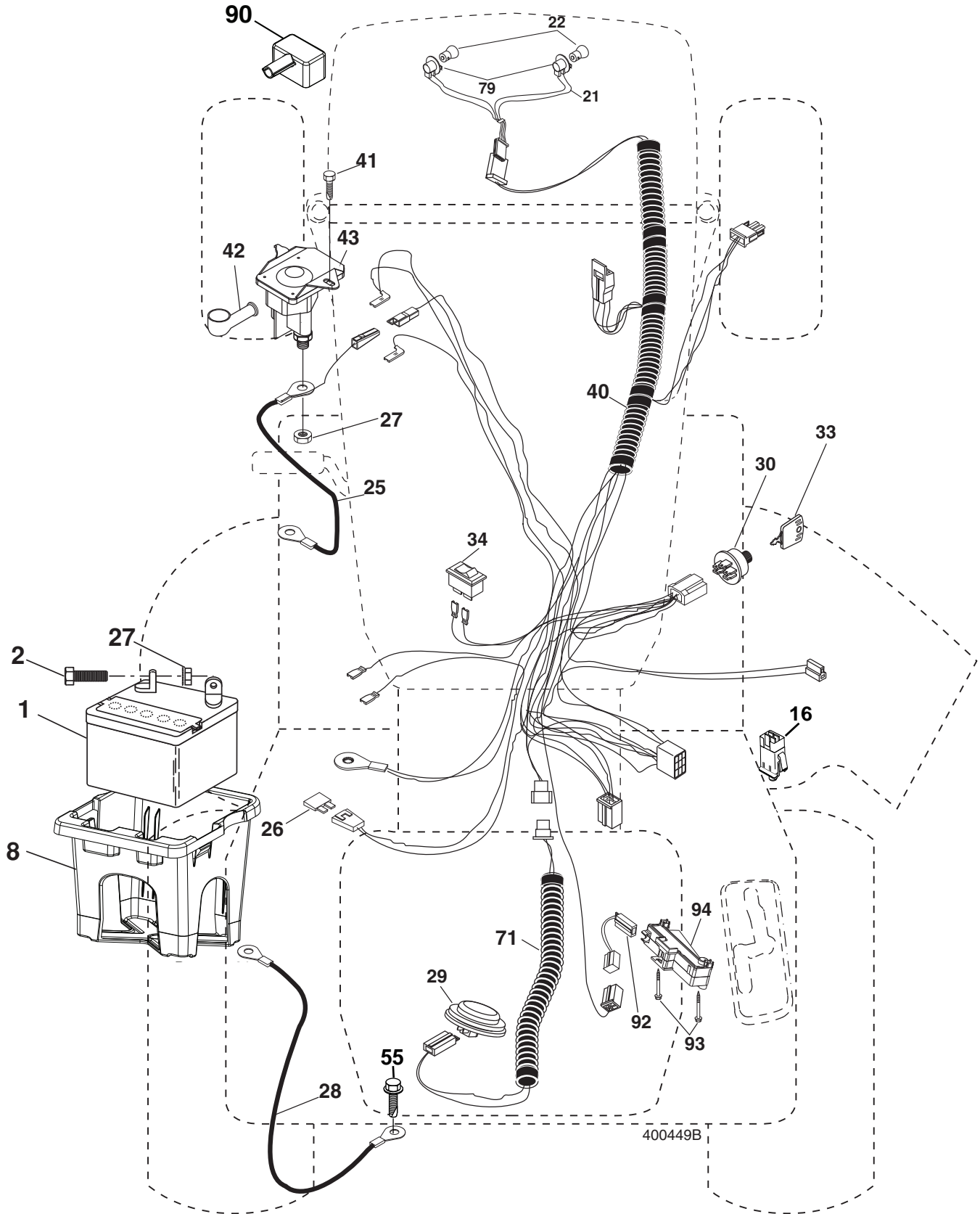

400449B

**TRACTOR - - MODEL NUMBER LT151 (96041001700), PRODUCT NO. 960 41 00-17
ELECTRICAL 32**

KEY NO.	PART NO.	DESCRIPTION
1	532 14 49-27	Battery
2	874 76 04-12	Bolt Hex Head 1/4-20 x 3/4
8	532 19 32-28	Box Battery
16	532 17 61-38	Switch Interlock Push-In
21	532 40 02-52	Harness Socket Light W/4152J
22	532 00 41-52	Bulb Light
25	532 40 16-62	Cable Starter
26	532 17 51-58	Fuse
27	873 51 04-00	Nut Keps Hex 1/4-20 unc
28	532 19 88-85	Cable, Ground
29	532 19 27-49	Switch, Seat
30	532 19 33-50	Switch, Ign
33	532 14 04-01	Key, Ignition
34	532 11 07-12	Switch Light / Reset
40	532 40 04-49	Harness Ign.
41	817 72 04-08	Screw Thd Cut 1/4-20 x 1/2
42	532 13 15-63	Cover, Terminal
43	532 19 25-07	Solenoid
55	817 06 05-12	Screw Thdrol 5/16-18 x 3/4 TYTT
71	532 40 10-98	Harness Ign. Dash
79	532 17 52-42	Socket Asm
90	532 40 07-25	Cover Terminal
92	532 19 66-15	Harness Pigtail Reverse Switch
93	532 19 25-40	Screw Plastite 10-14 x 2.0
94	532 19 18-34	Module Reverse ROS

NOTE: All component dimensions given in U.S. inches
1 inch = 25.4 mm

TRACTOR - - MODEL NUMBER LT151 (96041001700), PRODUCT NO. 960 41 00-17
CHASSIS **39**

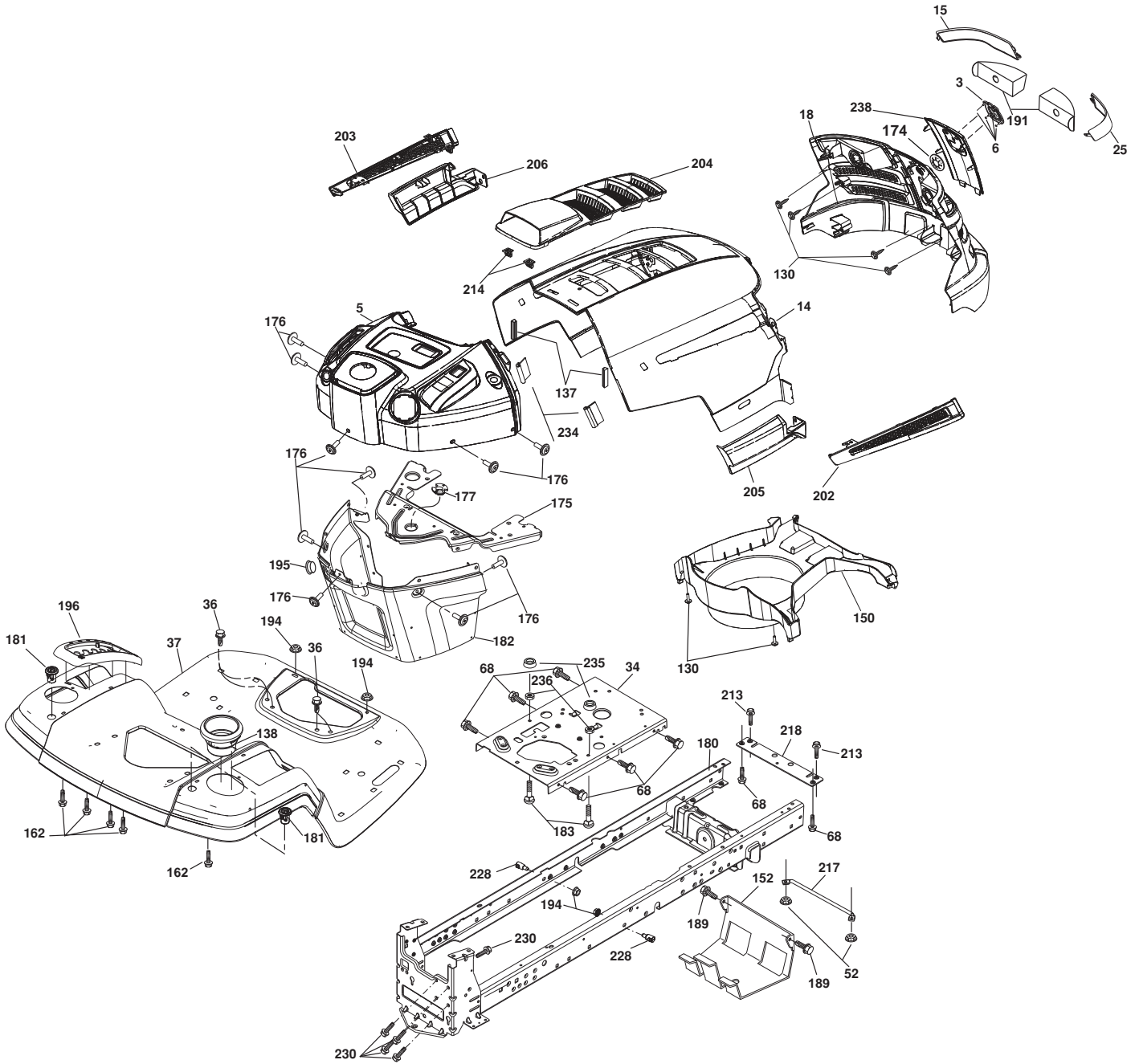

chassis-tex_23-gt-husq

**TRACTOR - - MODEL NUMBER LT151 (96041001700), PRODUCT NO. 960 41 00-17
CHASSIS 39**

KEY NO.	PART NO.	DESCRIPTION
3	532 40 50-12	Logo
5	532 40 75-92	Dash
6	532 40 48-83	Clip Tinnerman
14	532 41 10-73	Hood
15	532 41 10-79	Lens LH
18	532 40 66-67	Grille/Lens Asm.
25	532 41 10-78	Lens RH
34	532 19 61-25	Plate Engine
36	817 06 06-12	Screw 5/16-18 x 3/4
37	532 40 29-53	Fender
52	873 68 05-00	Nut Crown Lock 5/16
68	817 49 05-08	Screw THDROL 5/16-18 x 1/2
130	532 19 16-11	Screw 10 x 3/4 Single Lead-Hex
137	532 40 75-90	Bumper Dash
138	532 40 29-54	Cupholder
150	532 40 75-37	Air Duct
152	532 19 95-35	Shield Browning
162	532 14 24-32	Screw
175	532 19 94-72	Crossmember
176	532 40 07-76	Screw 10-24 x 5/8
177	532 19 52-28	Bushing Steering
180	532 19 54-57	Chassis
181	532 40 30-25	Bushing Mtg. Fender Crgo
182	532 19 89-17	Dash Lower
183	874 78 05-20	Bolt 5/16-18 UNC x 1-1/4
189	817 00 05-12	Screw 5/16-18 x 3/4
191	532 40 66-65	Insert Reflective
194	873 90 05-00	Nut Lock Hex Flange 5/16-18
195	532 41 11-15	Plug Dash
196	532 40 28-43	Console Asm. Deck Lift
202	532 41 10-74	Vent Side Hood RH
203	532 41 10-75	Vent Side Hood LH
204	532 41 11-16	Vent Top Hood
205	532 41 10-76	Skirt Side RH
206	532 41 10-77	Skirt Side LH
213	874 76 05-12	Bolt 5/16-18 x 3/4
214	532 19 91-45	Clip Retainer
217	532 15 65-24	Rod Pivot Hood
218	532 19 63-95	X-Piece Hood Stop
228	532 19 51-61	Stud Fastener
230	532 17 01-65	Bolt Shoulder 5/16-18
234	532 40 47-42	Bumper Hood
235	532 40 61-29	Spacer Fender
236	873 93 05-00	Nut Lock 5/16-18 UNC
238	532 41 11-19	Trim
239	532 11 04-52	Nut Push

NOTE: All component dimensions given in U.S. inches
1 inch = 25.4 mm

**TRACTOR - - MODEL NUMBER LT151 (96041001700), PRODUCT NO. 960 41 00-17
DRIVE 40**

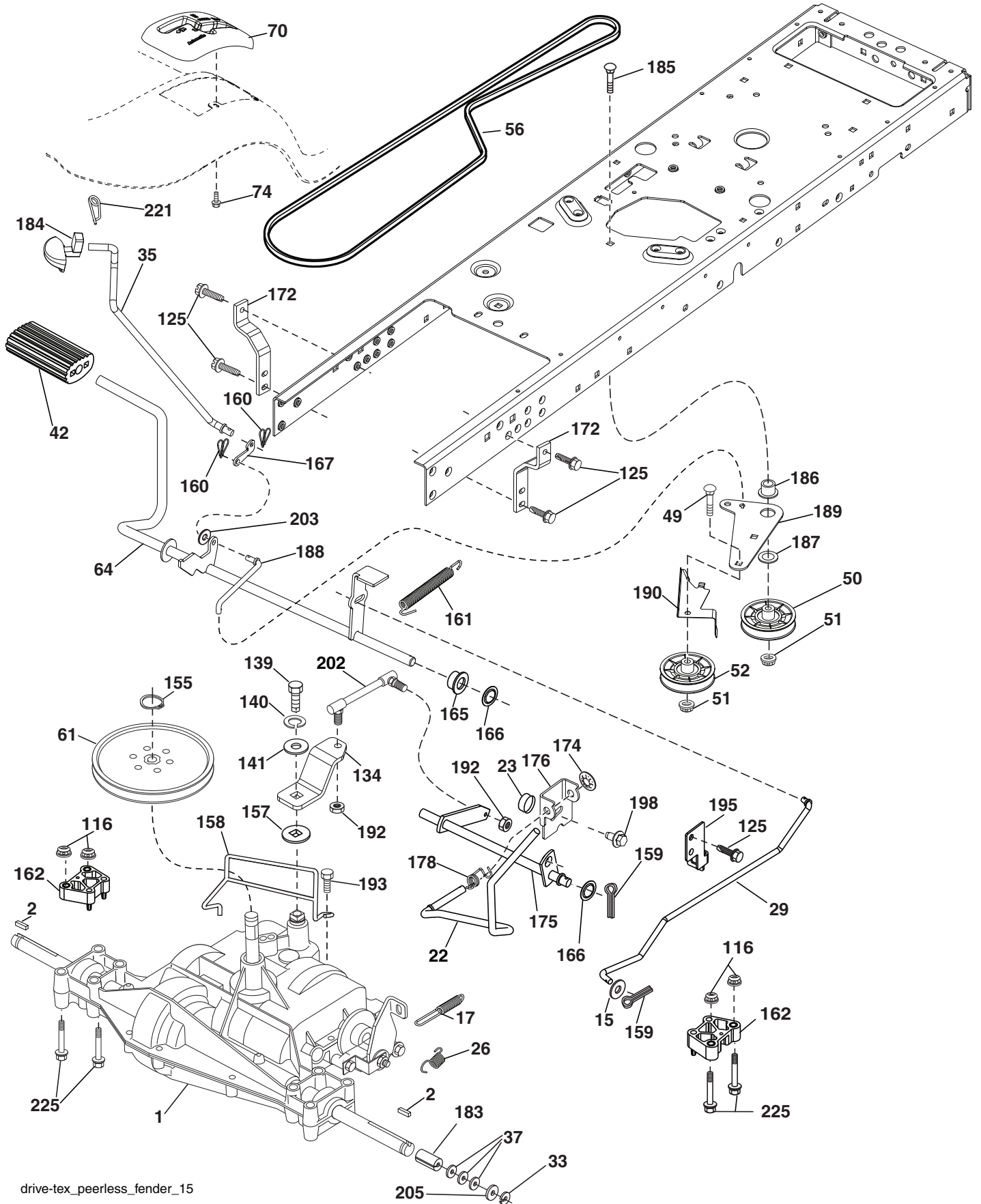

drive-tex_peerless_fender_15

**TRACTOR - - MODEL NUMBER LT151 (96041001700), PRODUCT NO. 960 41 00-17
DRIVE **40****

KEY NO.	PART NO.	DESCRIPTION	KEY NO.	PART NO.	DESCRIPTION
1	-----	Transaxle, Peerless 206-565 (Order Parts from Transaxle Manufacturer)	161	532 19 54-03	Spring, Return, Clutch
2	532 12 35-83	Key Square	162	532 19 57-85	Spacer Transaxle
15	819 13 13-16	Washer 13/32 x 13/16 x 16 Ga.	165	532 19 62-12	Bushing Shaft Brake Hand Control
17	532 19 72-97	Spring, Brake	166	532 19 72-90	Nut Push .625
22	532 19 76-60	Rod Shift	167	532 40 52-57	Latch Brake Parking
23	532 12 12-74	Knob Duckhead 1/2-13	172	532 19 76-57	Strap Torque LH
26	532 19 74-55	Spring Brake Return	174	532 19 72-89	Nut Push
29	532 19 72-67	Rod, Brake	175	532 19 78-58	Shaft Asm. Shift
33	812 00 00-01	Ring E	176	532 19 62-14	Arm Clevis Rod Shift
35	532 40 10-31	Rod, Brake, Park	178	532 19 74-56	Spring Shift
37	532 12 17-49	Washer 25/32 x 1-1/4 x 16 Ga.	183	532 13 70-57	Spacer Axle
42	532 12 48-72	Cover, Foot Pedal	184	532 40 97-47	Knob
49	872 11 06-14	Bolt	185	872 11 06-20	Bolt
50	532 19 43-27	Pulley Idler Flat	186	532 19 43-21	Spacer Retainer
51	873 90 06-00	Lock Nut 3/8-16	187	819 13 32-10	Washer
52	532 19 43-26	Idler V-Groove	188	532 19 43-23	Link Clutch Ground Drive
56	532 19 43-46	V-Belt, Drive	189	532 19 43-17	Bellcrank Ground Drive
61	532 12 36-66	Pulley transaxle	190	532 19 43-18	Keeper Bellcrank Ground Drive
64	53219 62-00	Shaft Asm. Pedal Brake Control	192	532 15 03-60	Nut Lock Center 1/4-28 Fnthd
70	532 40 30-24	Console	193	817 06 05-12	Screw 5/16-18 x 3/4
74	532 14 24-32	Screw 1/4 x 1/2	195	532 19 73-32	Bracket Brake Rod
116	873 90 05-00	Nut Lock Hex Flange 5/16-18	198	532 19 94-96	Screw 7/16-14 x 7/8
125	817 00 05-12	Screw 5/16-18 x 3/4	202	532 16 62-31	Link Transaxle
134	532 19 78-57	Asm Shift	203	819 11 11-16	Washer 11/32 x 11/16 x 16 Ga.
139	874 55 04-12	Bolt 1/4-28 unf Gr. 8 w/Patch	205	532 12 17-48	Washer 25/32 x 1-5/8 16 Ga.
140	810 04 04-00	Washer Lock Hvy Helical 1/4	221	532 40 31-87	Retainer Spring Clip Handle
141	819 09 12-10	Washer 9/32 x 3/4 x 10 Ga.	225	874 49 05-60	Bolt 5/16-18 x 3.75
155	812 00 00-28	Ring Retainer			
157	532 10 57-01	Washer Plate Shift			
158	532 19 43-52	Belt Keeper			
159	876 02 04-12	Pin Cotter 1/8 x 3/4			
160	532 16 94-84	Retainer Clip			

NOTE: All component dimensions given in U.S. inches
1 inch = 25.4 mm

**TRACTOR - - MODEL NUMBER LT151 (96041001700), PRODUCT NO. 960 41 00-17
ENGINE 24**

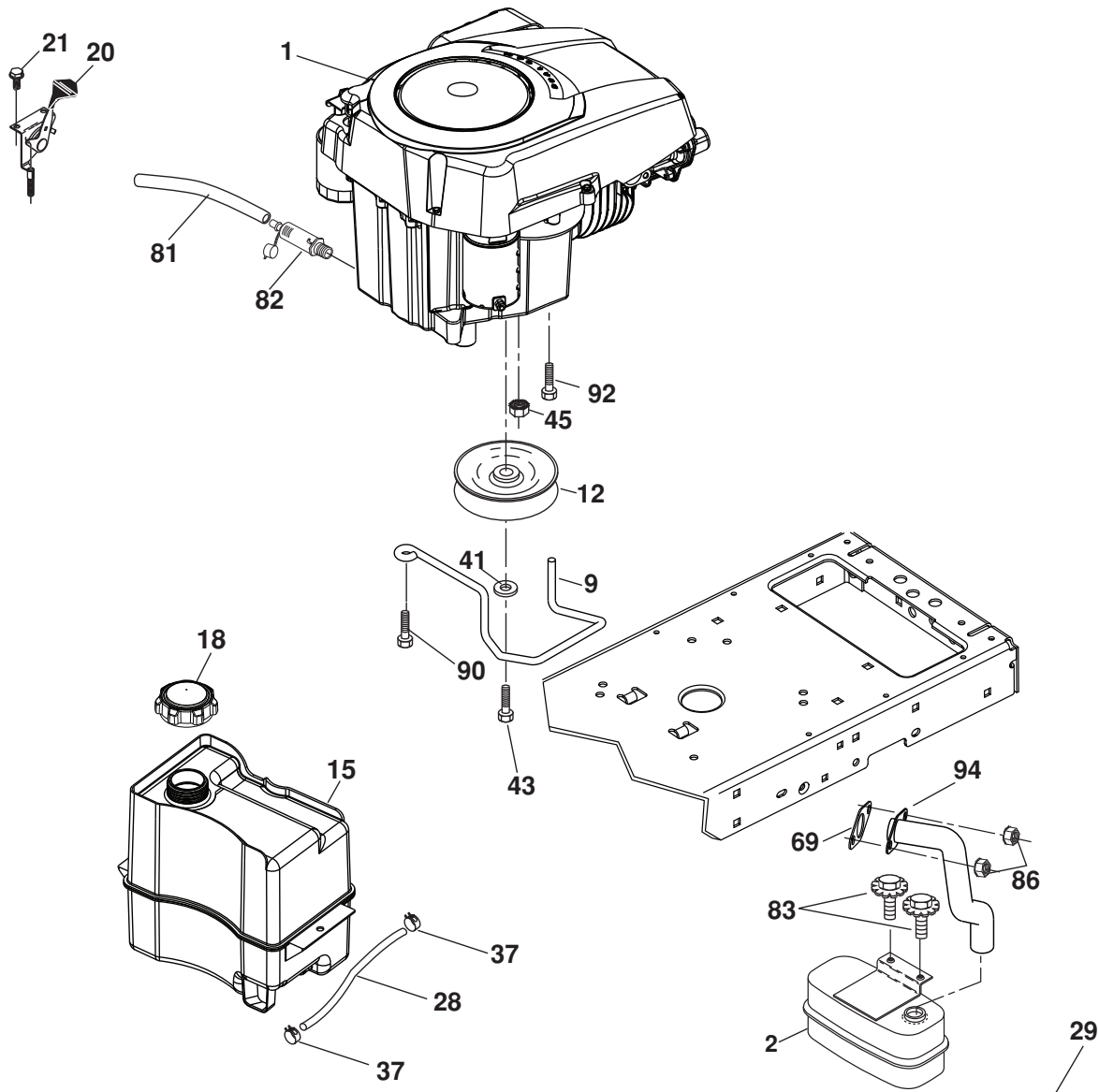

SPARK ARRESTER KIT

engine-tex_7-kohl

KEY NO.	PART NO.	DESCRIPTION
1	-----	Engine Kohler Model No. SV470
2	532 18 86-55	Muffler
9	532 19 43-19	Keeper Belt Engine
12	532 40 19-85	Pulley Engine
15	532 40 75-45	Tank Fuel 1.5
18	532 19 77-25	Cap Asm
20	532 18 38-97	Control Throttle
21	532 19 16-11	Screw 10 x 3/4 Single Lead-Hex
28	532 13 70-40	Fuel Line
29	532 13 71-80	Spark Arrester Kit
37	532 12 34-87	Clamp Hose
41	810 04 07-00	Bolt 5/16-18 unc x 3/4 w/Sems
43	532 17 39-37	Bolt Hex 7/16-20 x 4 Gr. 5
45	873 51 04-00	Nut Keps Hex 1/4-20 unc
69	-----	Gasket (Order From Eng. Mfgr.)
81	148456	Tube Drain Oil Easy

KEY NO.	PART NO.	DESCRIPTION
82	181654	Plug Drain Oil
83	532 17 18-77	Bolt 5/16-18 unc x 3/4 w/Sems
86	532 18 43-62	Nut M8-1.25
90	817 00 06-16	Screw 3/8-16 x 1
92	817 12 06-16	Screw 3/8-16 x 1
94	532 18 86-54	Tube Exhaust
96	819 09 14-16	Washer 9/32 x 7/8 x 16 Ga.
97	817 67 04-12	Screw 1/4-20 x 3/4

NOTE: All component dimensions given in U.S. inches
1 inch = 25.4 mm

**TRACTOR - - MODEL NUMBER LT151 (96041001700), PRODUCT NO. 960 41 00-17
STEERING ASSEMBLY 41**

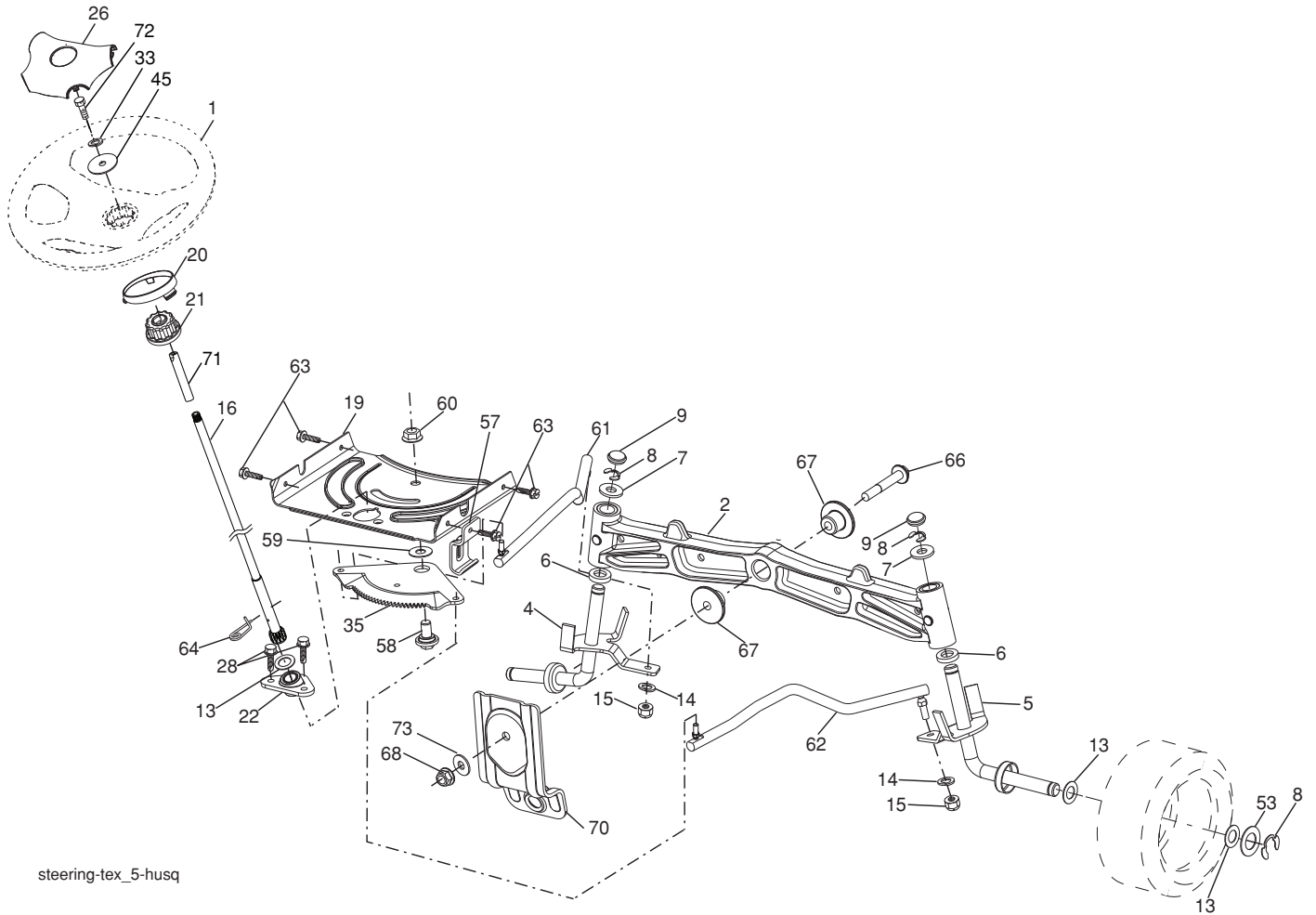

steering-tex_5-husq

KEY NO.	PART NO.	DESCRIPTION	KEY NO.	PART NO.	DESCRIPTION
1	532 19 39-43	Wheel, Steering	53	532 18 89-67	Washer Hardened .793 x 1.637 x .060
2	532 19 56-73	Axle Asm., Front	57	532 40 74-65	Bracket Upstop
4	532 40 30-87	Spindle Asm., LH	58	532 19 47-47	Bolt Shoulder Sector Pivot CFM
5	532 40 30-88	Spindle Asm., RH	59	532 19 47-48	Washer Thrust Sector Steering
6	532 12 49-31	Bearing, Race Thrust Harden	60	873 97 10-00	Nut Flange Lock 5/8-11
7	532 12 17-48	Washer 25/32 x 1-5/8 x 16 Ga.	61	532 19 47-40	Draglink LH
8	812 00 00-29	Ring, Klip #T5304-75	62	532 19 47-41	Draglink, RH
9	532 12 12-32	Cap, Spindle	63	817 00 05-12	Screw 5/16-18 x 3/4
13	532 12 17-49	Washer 25/32 x 1-1/4 x 16 Ga.	64	532 19 98-49	Retainer Clip Spring Steering
14	810 04 06-00	Washer, Lock Hvy Hlcl Spr 3/8	66	871 02 07-48	Bolt Hex Fghd 7/16-14 x 3 Serr
15	873 54 06-00	Nut, Crown Lock 3/8-24 unf	67	532 19 47-37	Bushing PM Front Axle
16	532 19 60-74	Shaft Steering	68	873 90 07-00	Nut Lock Flange 7/16-14 Gr. 5
19	532 19 47-29	Plate Steering	70	532 19 61-97	Bracket Deck Susp. Front
20	532 41 11-39	Boot, Steering	71	532 19 60-75	Shaft Extension Steering
21	532 18 67-37	Adapter, Wheel Steering	72	874 78 05-72	Bolt 5/16-18 UNC x 4.5. Gr. 5
22	532 19 48-45	Bushing, Strg. Blk	73	532 19 91-62	Washer 1.5 x .505 x .118
26	532 19 36-52	Insert, Wheel Steering			
28	817 00 06-12	Screw 3/8-16 x 3/4			
33	810 04 05-00	Washer Lock 5/16			
35	532 19 47-32	Gear, Sector Plate			
45	819 11 38-12	Washer 11/32 x 3/8 x 12 Ga.			

NOTE: All component dimensions given in U.S. inches
1 inch = 25.4 mm

TRACTOR - - MODEL NUMBER LT151 (96041001700), PRODUCT NO. 960 41 00-17
MOWER DECK 44

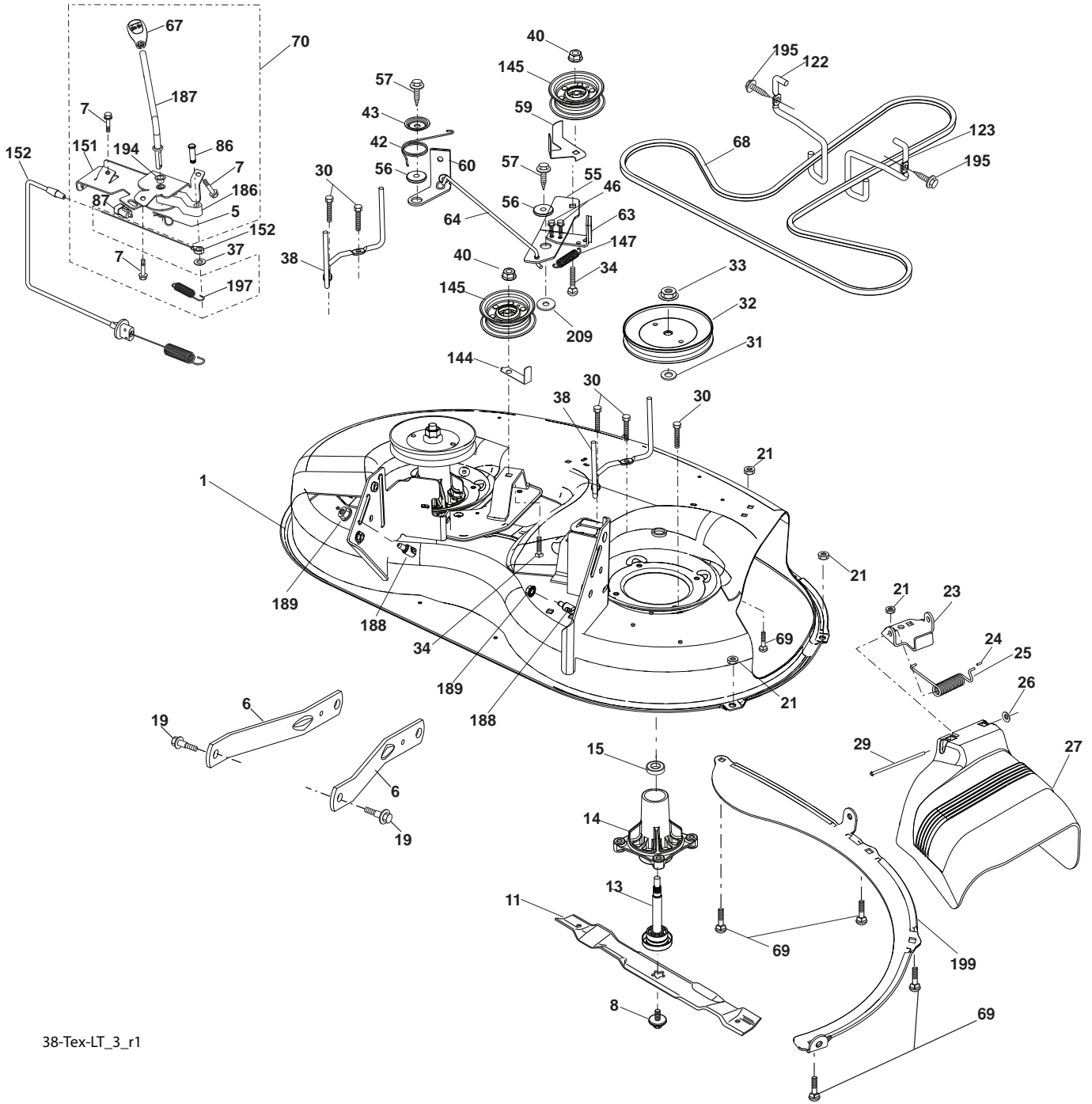

38-TEX-LT_3_r1

**TRACTOR - - MODEL NUMBER LT151 (96041001700), PRODUCT NO. 960 41 00-17
MOWER DECK 44**

KEY NO.	PART NO.	DESCRIPTION	KEY NO.	PART NO.	DESCRIPTION
1	532 19 42-51	Mower Housing	64	532 19 97-90	Link Brake
5	532 12 46-70	Retainer Spring	67	532 40 30-12	Handle Clutch Cable
6	532 19 51-86	Arm Suspension	68	532 40 83-81	V-Belt
7	532 19 16-11	Screw 10 x 3/4 Single Lead Hex	69	872 14 05-05	Bolt
8	532 19 30-03	Bolt/Washer asm 7/16-20 unf	70	532 40 12-46	Clutch Asm Manual
11	532 19 39-57	Blade	86	532 19 77-98	Pin Attachment Cable
13	532 19 28-72	Shaft Assembly, Mandrel	87	532 19 78-02	Switch Interlock Clutch Cable
14	532 18 72-81	Housing, Mandrel	122	532 19 72-58	Keeper Belt Engine LH
15	532 11 04-85	Bearing, Ball, Mandrel	123	532 19 72-59	Keeper Belt Engine RH
19	532 19 65-39	Bolt, Shoulder	144	532 15 60-85	Keeper Belt
21	873 68 05-00	Nut, Crownlock 5/16-18 unc	145	532 19 31-97	Pulley, Idler, Flat
23	532 19 25-57	Bracket, Deflector	147	532 40 18-72	Spring Return
24	532 10 53-04	Cap, Sleeve	151	532 40 12-44	Bracket
25	532 19 70-26	Spring, Torsion, Deflector	152	532 40 87-14	Manual Clutch Cable
26	532 11 04-52	Nut, Push	186	532 19 77-99	Arm Actuator
27	532 40 14-72	Shield, Deflector	187	532 40 12-45	Lever Control Clutch
29	532 13 14-91	Rod, Hinge	188	532 19 51-61	Stud Fastener
30	532 17 39-84	Screw Thdrol Rolling Wsh Hd	189	873 90 05-00	Nut Lock Hex Flange
31	532 18 76-90	Washer, Spacer	194	532 19 77-97	Bearing Control Lever Clutch
32	532 19 97-89	Pulley, Mandrel	195	817 00 06-12	Screw 3/8-16 x 3/4
33	532 40 02-34	Nut, Toplock, Flanged	197	532 19 78-01	Spring Plunger Actuator
34	872 11 06-12	Bolt Carr Sh. 3/8-16 x 1-1/2 Gr. 5	199	532 40 00-95	Baffle Vortex
37	819 13 13-16	Washer	209	819 13 32-10	Washer 13/32 x 2 x 10
38	532 19 95-41	Keeper Belt LH Mandrel	--	532 19 28-70	Mandrel Assembly (Includes housing, shaft and shaft hardware only-pulley not included)
40	873 90 06-00	Nut, Lock Flg. 3/8-16 unc	--	532 40 04-22	Replacement Mower, Complete
42	532 19 84-10	Spring Torsion Brake			
43	532 19 72-56	Spring Torsion Retainer			
46	532 13 77-29	Screw 1/4-20 x 5/8			
55	532 19 72-49	Arm, Idler			
56	532 19 90-92	Spacer, Retainer			
57	817 12 06-16	Screw 3/8-16 x 1			
59	532 14 10-43	Guard, Tuv Idler			
60	532 19 94-71	Arm Brake Mower			
63	532 19 94-70	Arm Brake Mower			

NOTE: All component dimensions given in U.S. inches
1 inch = 25.4 mm

**TRACTOR - - MODEL NUMBER LT151 (96041001700), PRODUCT NO. 960 41 00-17
SEAT ASSEMBLY 42**

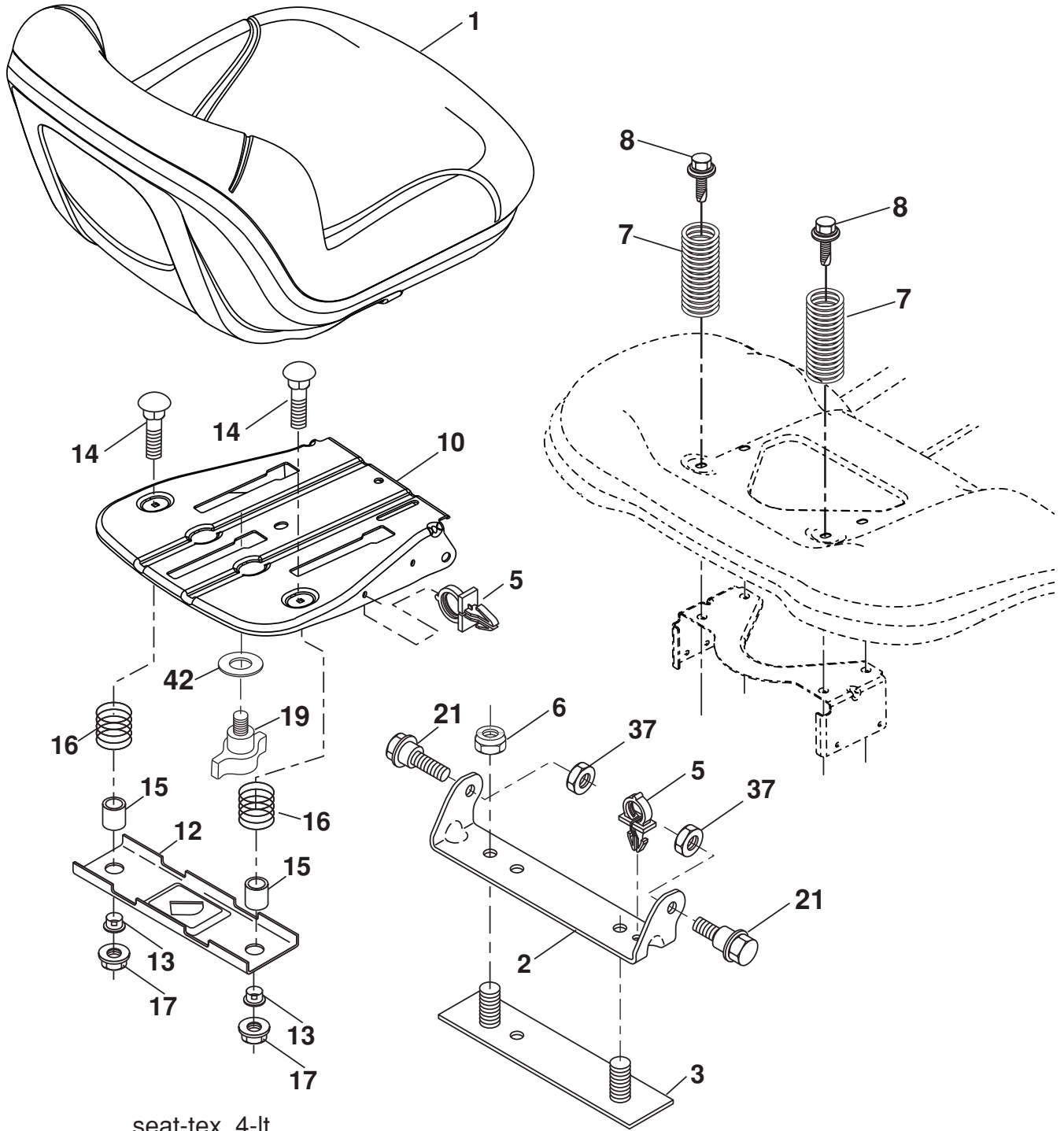

seat-tex_4-lt

KEY NO.	PART NO.	DESCRIPTION
1	532 19 75-18	Seat
2	532 18 01-66	Bracket Pivot Fender
3	532 14 06-75	Strap, Asm Fender
4	532 14 50-06	Clip, Push In, Hinged
5	873 80 06-00	Nut, Lock W/Ins. 3/8-16 unc
6	532 12 41-81	Spring, Seat Cprsn
7	532 17 18-77	Bolt 5/16-18 unc x 3/4 w/Sems
8	532 19 91-80	Pan, Seat
9	532 19 93-70	Bracket Mnt Seat
10	532 12 12-48	Bushing Snap

KEY NO.	PART NO.	DESCRIPTION
11	872 05 04-12	Bolt 1/4-20 x 1/2
12	532 13 43-00	Spacer Split
13	532 12 37-40	Spring
14	532 12 39-76	Nut Lock 1/4
15	532 19 93-72	Knob Seat
16	532 17 18-52	Bolt, Shoulder 5/16-18
17	873 80 05-00	Nut, Lock 5/16-18 unc
18	532 19 93-71	Washer Cup Seat

NOTE: All component dimensions given in U.S. inches
1 inch = 25.4 mm

**TRACTOR - - MODEL NUMBER LT151 (96041001700), PRODUCT NO. 960 41 00-17
MOWER LIFT 45**

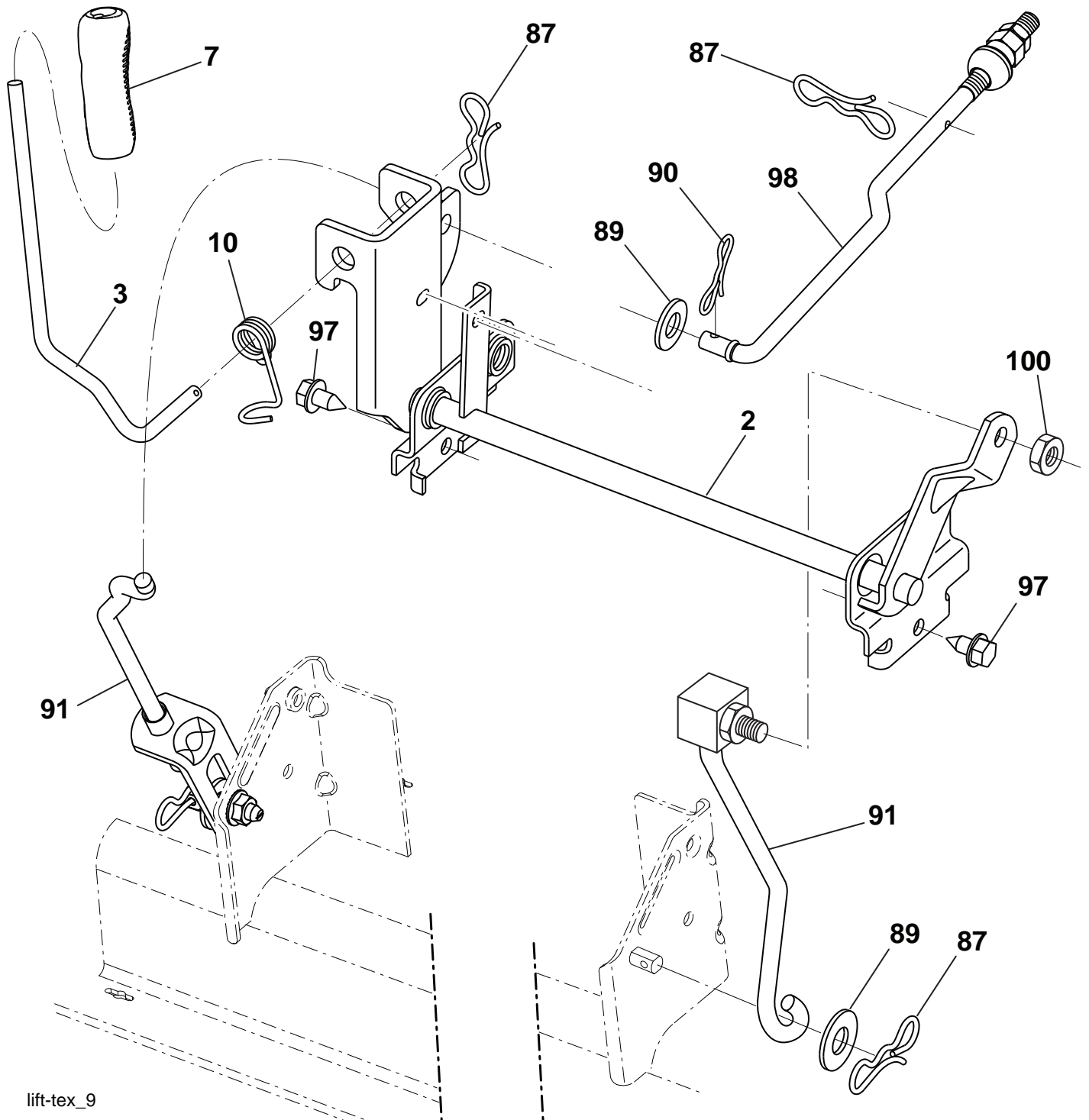

lift-tex_9

KEY NO.	PART NO.	DESCRIPTION
2	532 19 52-23	Shaft Asm., Lift
3	532 19 52-31	Lever Asm., Lift Rh
7	532 19 64-92	Grip, Lever
10	532 19 63-14	Spring Torsion
87	532 19 42-09	Pin Cotter 7/16 Bow Tie Lock
89	819 19 19-12	Washer Clear Zinc
90	532 19 42-08	Pin Cotter 5/16 Bow Tie Lock
91	532 19 51-79	Link Lift Susp Mower Rear

KEY NO.	PART NO.	DESCRIPTION
97	817 06 06-12	Screw 3/8-16 x .75 Smgml Tap/R.Z
98	532 19 52-70	Link Lift Susp. Front Mower
100	873 93 06-00	Nut Centerlock 3/8-16

NOTE: All component dimensions given in U.S. inches
1 inch = 25.4 mm