

LTH151

Spare parts

Ersatzteile

Pièces détachées

Reserve onderdelen

Repuestos

Reservdelar

ILLUSTRATED PARTS LIST

MODEL NO. 96041001901

CUSTOMER CATALOG NO. LTH151

PRODUCT NO. 960 41 00-19

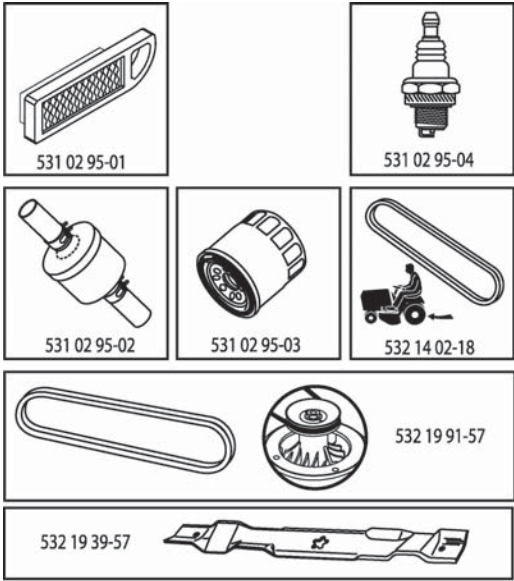

408772

**TRACTOR - - MODEL NUMBER LTH151 (96041001901), PRODUCT NO. 960 41 00-19
DECALS**

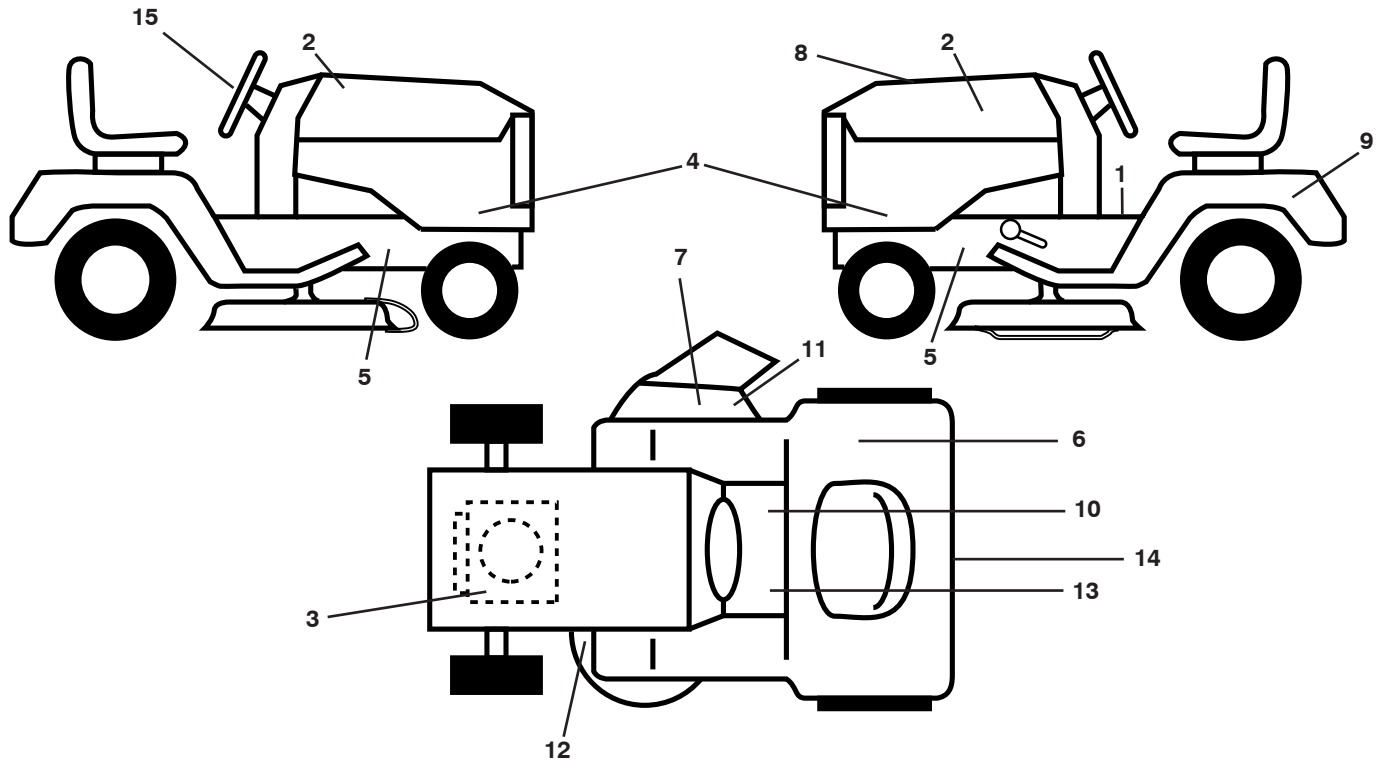

| KEY NO. | PART NO. | DESCRIPTION |
|---------|---------------------|-----------------------------|
| 1 | 532 40 03-89 | Decal, Operators |
| 2 | 532 40 28-32 | Decal, Hood |
| 3 | 532 19 68-41 | Decal, Warning Eng. Symbols |
| 4 | 532 40 85-97 | Decal, Hood Panel |
| 5 | 532 15 97-36 | Decal, Chassis Hot Muffler |
| 6 | 532 18 04-32 | Decal, Fender 100 DB/CE |
| 7 | 532 18 21-66 | Decal, Cutfinger CE |
| 8 | 532 40 87-72 | Decal, Rpl Kohl |
| 9 | 532 14 50-05 | Decal, Battery Dnge/Poi |
| 10 | 532 14 08-37 | Decal, Saddle Brake Parking |
| 11 | 532 19 63-57 | Decal, Warning |

| KEY NO. | PART NO. | DESCRIPTION |
|---------|---------------------|-------------------------------|
| 12 | 532 19 43-02 | Decal, Mower V-Belt Schematic |
| 13 | 532 15 97-37 | Decal, Brake/Clutch Symbol |
| 14 | 532 40 28-32 | Decal, Hood/Fender Logo |
| 15 | 532 40 44-84 | Decal, WHL. STRG. |
| -- | 532 16 69-60 | Decal, Bypass |
| -- | 532 16 25-98 | Decal, Drawbar |
| -- | 532 41 08-05 | Pad, Footrest, LH |
| -- | 532 41 10-56 | Pad, Footrest, RH |
| -- | 532 40 89-59 | Manual Oper. Euro |
| -- | 532 40 89-60 | Manual Oper. Scand |
| -- | 532 40 89-61 | Manual Oper. E-Bloc |
| -- | 532 40 89-62 | Manual Oper. Baltic |

WHEELS AND TIRES

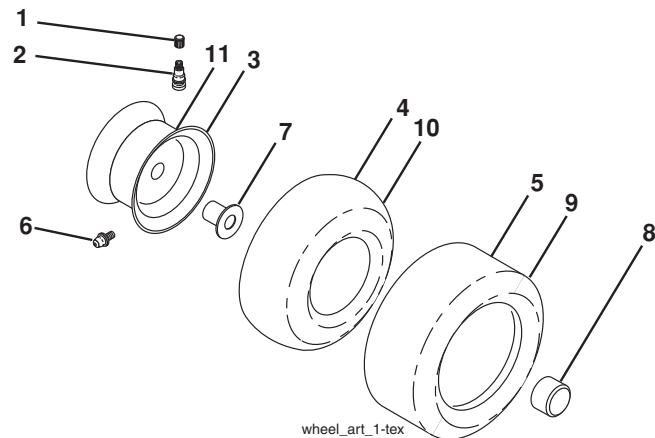

| KEY NO. | PART NO. | DESCRIPTION |
|---------|---------------------|-----------------------------------|
| 1 | 532 05 91-92 | Cap Valve Tire |
| 2 | 532 06 51-39 | Stem Valve |
| 3 | 532 13 83-36 | Rim Asm 6" Front Service |
| 4 | 532 05 99-04 | Tube Front (Service Item Only) |
| 5 | 532 10 62-22 | Tire F T 15 x 6 0 - 6 Service |
| 6 | 532 12 49-57 | Fitting Grease (Front Wheel Only) |
| 7 | 532 12 49-59 | Bearing Flange (Front Wheel Only) |
| 8 | 532 17 50-39 | Cap Axle Blk 1 50 x 1 00 |
| 9 | 532 10 62-68 | Tire R 18 x 9.5-8 |
| 10 | 532 12 49-26 | Tube Rear (Service Item Only) |
| 11 | 532 13 83-37 | Rim Asm 8" Rear Service |
| -- | 532 14 43-34 | Sealant, Tire (10 oz. Tube) |

NOTE: All component dimensions given in U.S. inches
1 inch = 25.4 mm

TRACTOR - - MODEL NUMBER LTH151 (96041001901), PRODUCT NO. 960 41 00-19 SCHEMATIC

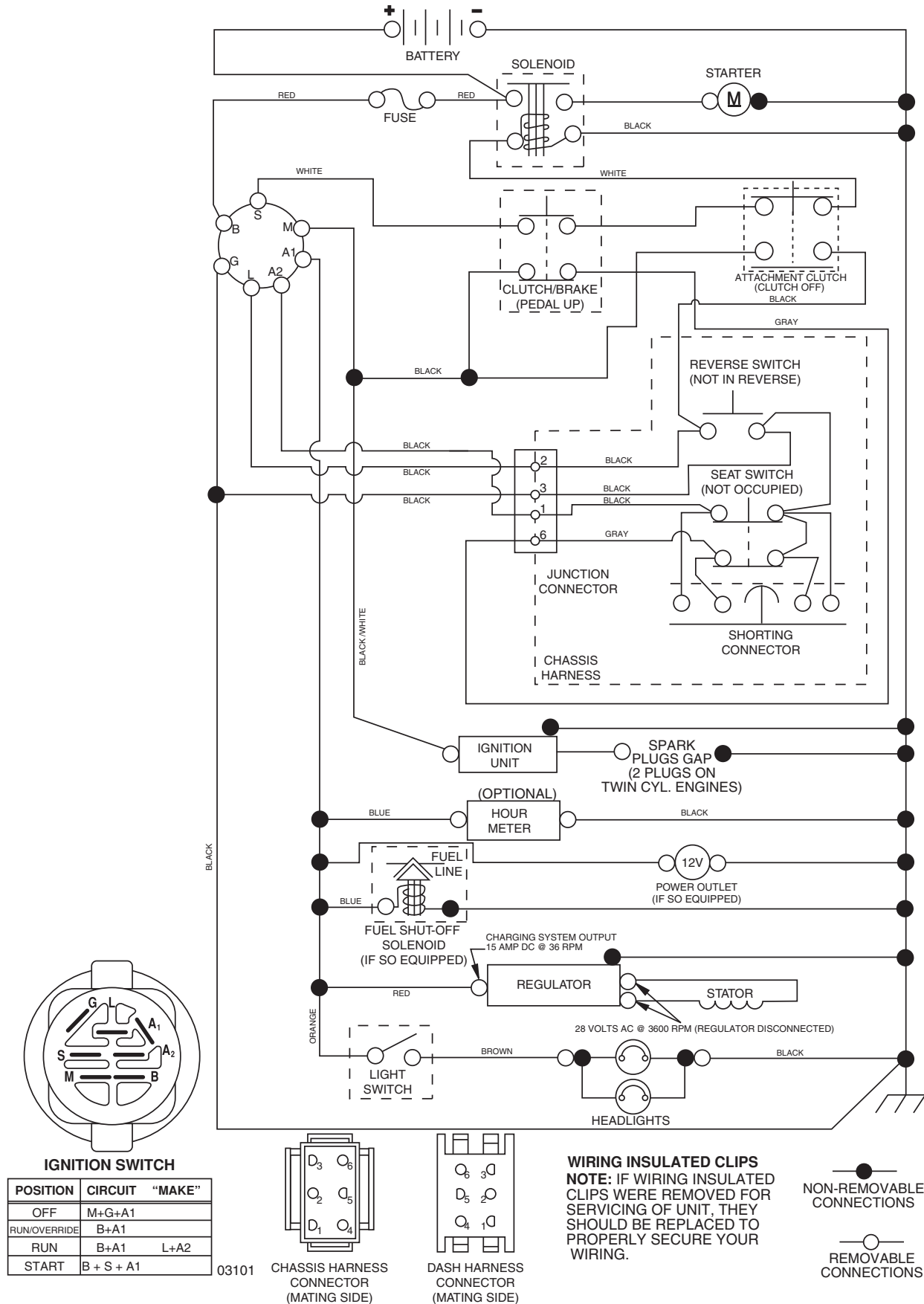

**TRACTOR - - MODEL NUMBER LTH151 (96041001901), PRODUCT NO. 960 41 00-19
ELECTRICAL**

| KEY NO. | PART NO. | DESCRIPTION |
|----------------|-----------------|---------------------------------|
| 1 | 532 14 49-27 | Battery |
| 2 | 874 76 04-12 | Bolt Hex Head 1/4-20 x 3/4 |
| 8 | 532 19 32-28 | Box Battery |
| 16 | 532 17 61-38 | Switch Interlock Push-In |
| 21 | 532 40 02-52 | Harness Socket Light W/4152J |
| 22 | 532 00 41-52 | Bulb Light |
| 25 | 532 40 16-62 | Cable Starter |
| 26 | 532 17 51-58 | Fuse |
| 27 | 873 51 04-00 | Nut Keps Hex 1/4-20 unc |
| 28 | 532 19 88-85 | Cable, Ground |
| 29 | 532 40 15-45 | Switch, Seat |
| 30 | 532 19 33-50 | Switch, Ign |
| 33 | 532 14 04-01 | Key, Ignition |
| 34 | 532 11 07-12 | Switch Light / Reset |
| 40 | 532 40 10-98 | Harness Ign. Dash |
| 41 | 817 72 04-08 | Screw Thd Cut 1/4-20 x 1/2 |
| 42 | 532 13 15-63 | Cover, Terminal |
| 43 | 532 19 25-07 | Solenoid |
| 55 | 817 06 05-12 | Screw Thdrol 5/16-18 x 3/4 TYTT |
| 71 | 532 40 04-49 | Harness Ign. |
| 79 | 532 17 52-42 | Socket Asm |
| 90 | 532 40 07-25 | Cover Terminal |
| 92 | 532 19 66-15 | Harness Pigtail Reverse Switch |
| 93 | 532 19 25-40 | Screw Plastite 10-14 x 2.0 |
| 94 | 532 19 18-34 | Module Reverse ROS |

NOTE: All component dimensions given in U.S. inches
1 inch = 25.4 mm

**TRACTOR - - MODEL NUMBER LTH151 (96041001901), PRODUCT NO. 960 41 00-19
CHASSIS**

| KEY NO. | PART NO. | DESCRIPTION |
|--------------------|---------------------|--------------------------------|
| 3 | 532 40 50-12 | Logo |
| 5 | 532 40 75-92 | Dash |
| 14 | 532 41 10-73 | Hood |
| 15 | 532 41 10-79 | Lens LH |
| 18 | 532 40 66-67 | Grille/Lens Asm. |
| 25 | 532 41 10-78 | Lens RH |
| 34 | 532 19 61-25 | Plate Engine |
| 36 | 817 06 05-12 | Screw 5/16-18 x 3/4 |
| 37 | 532 41 17-67 | Fender |
| 52 | 873 68 05-00 | Nut Crown Lock 5/16 |
| 68 | 817 49 05-08 | Screw THDROL 5/16-18 x 1/2 |
| 99 | 532 40 33-76 | Rod Asm. Bypass |
| 130 | 532 19 16-11 | Screw 10 x 3/4 Single Lead-Hex |
| 137 | 532 40 75-90 | Bumper Dash |
| 150 | 532 40 75-37 | Air Duct |
| 151 | 532 40 78-07 | Bracket Pivot |
| 152 | 532 19 95-35 | Shield Browning |
| 162 | 532 14 24-32 | Screw |
| 175 | 532 19 94-72 | Crossmember |
| 176 | 532 40 07-76 | Screw 10-24 x 5/8 |
| 177 | 532 19 52-28 | Bushing Steering |
| 180 | 532 19 54-57 | Chassis |
| 181 | 532 40 30-25 | Bushing Mtg. Fender Crgo |
| 182 | 532 19 89-17 | Dash Lower |
| 183 | 874 78 05-20 | Bolt 5/16-18 UNC x 1-1/4 |
| 189 | 817 00 05-12 | Screw 5/16-18 x 3/4 |
| 191 | 532 40 66-65 | Insert Reflective |
| 194 | 873 90 05-00 | Nut Lock Hex Flange 5/16-18 |
| 196 | 532 40 28-43 | Console Asm. Deck Lift |
| 202 | 532 41 10-74 | Vent Side Hood RH |
| 203 | 532 41 10-75 | Vent Side Hood LH |
| 204 | 532 41 11-16 | Vent Top Hood |
| 205 | 532 41 10-76 | Skirt Side RH |
| 206 | 532 41 10-77 | Skirt Side LH |
| 213 | 874 76 05-12 | Bolt 5/16-18 x 3/4 |
| 214 | 532 19 91-45 | Clip Retainer |
| 217 | 532 40 91-67 | Rod Pivot Hood |
| 218 | 532 19 63-95 | X-Piece Hood Stop |
| 228 | 532 19 51-61 | Stud Fastener |
| 230 | 532 17 01-65 | Bolt Shoulder 5/16-18 |
| 234 | 532 40 47-42 | Bumper Hood |
| 235 | 532 40 61-29 | Spacer Fender |
| 236 | 873 93 05-00 | Nut Lock 5/16-18 UNC |
| 238 | 532 41 11-19 | Trim |
| 239 | 532 40 48-83 | Clip Tinnerman |
| - - - | 532 41 11-15 | Plug Dash SRVMNDR |

NOTE: All component dimensions given in U.S. inches
1 inch = 25.4 mm

TRACTOR - - MODEL NUMBER LTH151 (96041001901), PRODUCT NO. 960 41 00-19 DRIVE

| KEY NO. | PART NO. | DESCRIPTION | KEY NO. | PART NO. | DESCRIPTION |
|---------|---------------------|---|---------|--------------|--------------------------------|
| 1 | ----- | Transaxle, Hydro 351-0510 (Order Parts from Transaxle Manufacturer) | 166 | 532 19 72-90 | Nut Push .625 |
| 2 | 532 12 35-83 | Key | 167 | 532 40 52-57 | Latch Brake Parking |
| 15 | 819 13 13-16 | Washer 13/32 x 13/16 x 16 Ga. | 169 | 874 49 05-60 | Bolt 5/16-18 x 3.75 |
| 17 | 532 19 72-96 | Spring, Brake | 170 | 532 19 43-22 | Keeper Belt Centerspan |
| 22 | 532 19 76-60 | Rod Shift | 171 | 872 11 06-22 | Bolt |
| 23 | 532 12 12-74 | Knob | 172 | 532 19 76-56 | Strap Torque LH |
| 29 | 532 19 76-59 | Rod, Brake | 173 | 532 19 76-55 | Strap Torque RH |
| 33 | 812 00 00-01 | Ring E | 174 | 532 19 72-89 | Nut Push |
| 35 | 532 40 10-31 | Rod, Brake, Park | 175 | 532 19 76-53 | Shaft Asm |
| 37 | 532 12 17-49 | Washer 25/32 x 1-1/4 x 16 Ga. | 176 | 532 19 62-14 | Asm Clevis Rod Shift |
| 42 | 532 12 48-72 | Cover, Foot Pedal | 178 | 532 19 74-56 | Spring Shift |
| 49 | 872 11 06-14 | Bolt | 183 | 532 13 70-57 | Spacer Axle |
| 50 | 532 19 43-27 | Pulley Idler Flat | 184 | 532 40 97-47 | Handle Parking Brake |
| 51 | 873 90 06-00 | Lock Nut 3/8-16 | 185 | 872 11 06-20 | Bolt |
| 52 | 532 19 43-26 | Idler V-Groove 910" Offset | 186 | 532 19 43-21 | Spacer Retainer |
| 56 | 532 14 02-18 | V-Belt, Drive | 187 | 819 13 32-10 | Washer |
| 64 | 532 19 62-00 | Shaft Asm. Pedal Brake Control | 188 | 532 19 43-23 | Link Clutch Ground Drive |
| 70 | 532 41 14-74 | Console Shift | 189 | 532 19 43-17 | Bellcrank Ground Drive |
| 73 | 874 49 05-44 | Bolt Hex Flghd 5/16-18 Gr. 5 | 190 | 532 19 43-18 | Keeper Bellcrank Ground Drive |
| 74 | 532 14 24-32 | Screw Hex WSH Hi-Lo 1/4 x 1/2 unc | 195 | 532 19 80-12 | Bracket Rod Brake |
| 114 | 873 80 05-00 | Nut Lock Hex W/INS 5/16-18 unc | 199 | 872 14 05-08 | Bolt RDHD SQNK 5/16-18 unc x 1 |
| 116 | 873 90 05-00 | Nut Lock Hex Flange 5/16-18 | 200 | 873 93 05-00 | Nut Center Lock 5/16-18 unc |
| 125 | 817 00 05-12 | Screw 5/16-18 x 3/4 | 201 | 532 16 96-12 | Bolt Shoulder 5/16-18 unc |
| 143 | 817 49 05-08 | Screw 5/16-18 x 1/2 | 202 | 532 19 77-15 | Link Trans |
| 159 | 876 02 04-12 | Pin Cotter 1/8 x 3/4 | 203 | 819 11 11-16 | Washer 11/32 x 11/16 x 16 Ga. |
| 160 | 532 16 94-84 | Retainer Clip | 205 | 532 12 17-48 | Washer 25/32 x 1-5/8 x 16 Ga. |
| 161 | 532 19 54-03 | Spring, Return, Clutch | 216 | 532 19 61-31 | Bracket Pulley |
| 162 | 532 19 57-85 | Spacer Transaxle | 221 | 532 40 31-87 | Retainer Spring Clip Handle |
| 165 | 532 19 62-12 | Bushing | 232 | 874 78 07-16 | Bolt 7/16-14 x 1 |
| | | | 233 | 532 40 52-96 | Washer Serrated |
| | | | 240 | 532 40 72-87 | Pulley V-Groove |

NOTE: All component dimensions given in U.S. inches
1 inch = 25.4 mm

**TRACTOR - - MODEL NUMBER LTH151 (96041001901), PRODUCT NO. 960 41 00-19
MOWER DECK**

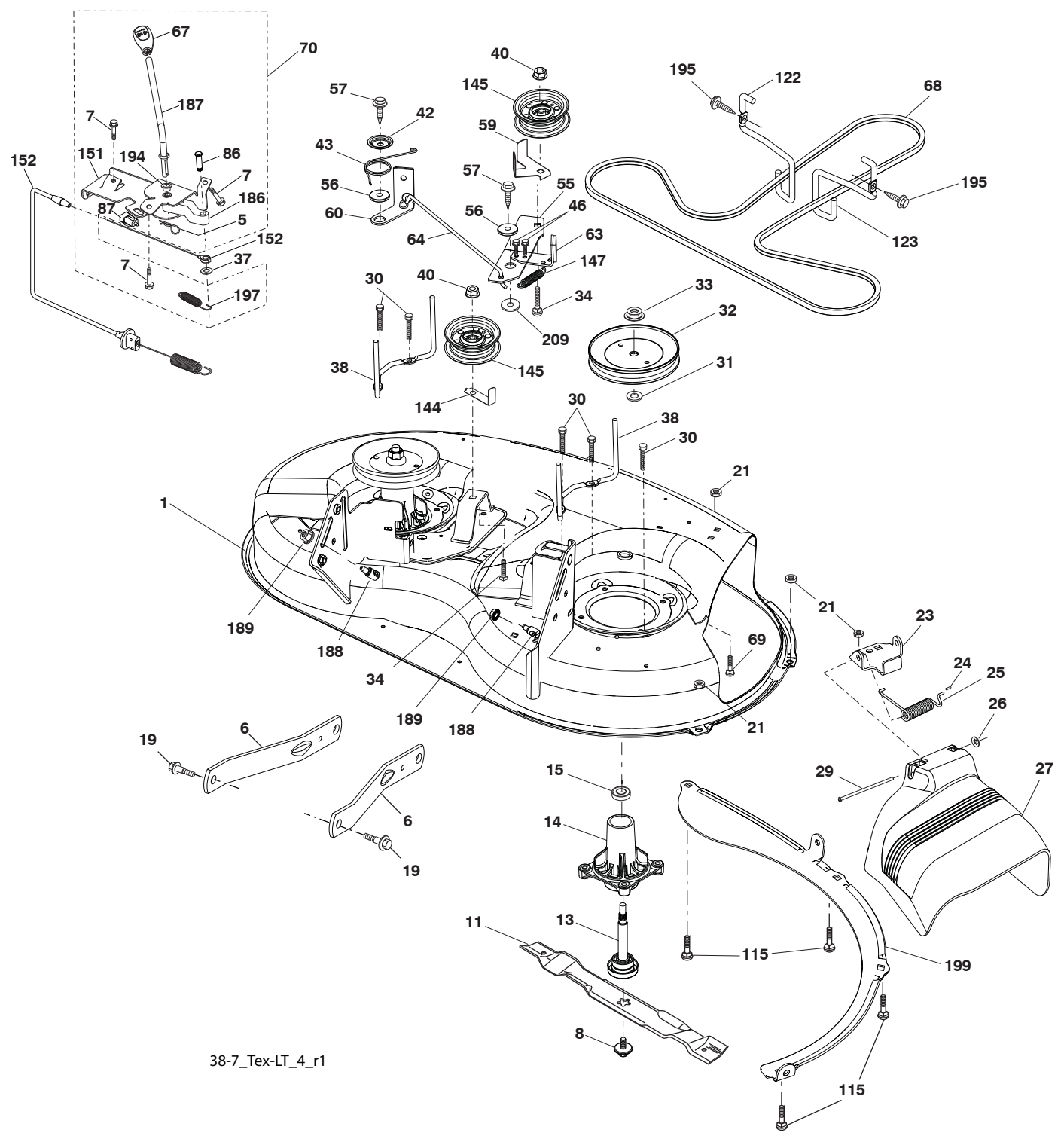

38-7_Tex-LT_4_r1

**TRACTOR - - MODEL NUMBER LTH151 (96041001901), PRODUCT NO. 960 41 00-19
MOWER DECK**

| KEY NO. | PART NO. | DESCRIPTION | KEY NO. | PART NO. | DESCRIPTION |
|---------|---------------------|---|---------|---------------------|--|
| 1 | 532 19 42-51 | Mower Housing | 59 | 532 14 10-43 | Guard, Tuv Idler |
| 5 | 532 12 46-70 | Retainer Spring | 60 | 532 19 94-71 | Arm Brake Mower |
| 6 | 532 19 51-86 | Arm Suspension | 63 | 532 19 94-70 | Arm Brake Mower |
| 7 | 532 19 16-11 | Screw 10 x 3/4 Single Lead Hex | 64 | 532 19 97-90 | Link Brake |
| 8 | 532 19 30-03 | Bolt/Washer asm 7/16-20 unf | 67 | 532 40 30-12 | Handle Clutch Cable |
| 11 | 532 19 39-57 | Blade, Premium, (For better wear when mulching) 38" 3NI | 68 | 532 40 83-81 | V-Belt |
| 13 | 532 19 28-72 | Shaft Assembly, Mandrel | 69 | 872 14 05-05 | Bolt |
| 14 | 532 18 72-81 | Housing, Mandrel | 70 | 532 40 12-46 | Clutch Asm Manual |
| 15 | 532 11 04-85 | Bearing, Ball, Mandrel | 86 | 532 19 77-98 | Pin Attachment Cable |
| 19 | 532 19 65-39 | Bolt, Shoulder | 87 | 532 19 78-02 | Switch Interlock Clutch Cable |
| 21 | 873 68 05-00 | Nut, Crownlock 5/16-18 unc | 115 | 872 11 05-05 | Bolt Carr. 5/16-18 x 5/8 |
| 23 | 532 19 25-57 | Bracket, Deflector | 122 | 532 19 72-58 | Keeper Belt Engine LH |
| 24 | 532 10 53-04 | Cap, Sleeve | 123 | 532 19 72-59 | Keeper Belt Engine RH |
| 25 | 532 19 70-26 | Spring, Torsion, Deflector | 144 | 532 19 34-14 | Keeper Belt |
| 26 | 532 11 04-52 | Nut, Push | 145 | 532 19 31-97 | Pulley, Idler, Flat |
| 27 | 532 40 14-72 | Shield, Deflector | 147 | 532 40 18-72 | Spring Return |
| 29 | 532 13 14-91 | Rod, Hinge | 151 | 532 40 12-44 | Bracket |
| 30 | 532 17 39-84 | Screw Thdrol Rolling Wsh Hd | 152 | 532 40 87-14 | Manual Clutch Cable |
| 31 | 532 18 76-90 | Washer, Spacer | 186 | 532 19 77-99 | Arm Actuator |
| 32 | 532 19 97-89 | Pulley, Mandrel | 187 | 532 40 12-45 | Lever Control Clutch |
| 33 | 532 40 02-34 | Nut, Toplock, Flanged | 188 | 532 19 51-61 | Stud Fastener |
| 34 | 872 11 06-12 | Bolt Carr Sh. 3/8-16 x 1-1/2 Gr. 5 | 189 | 873 90 05-00 | Nut Lock Hex Flange |
| 37 | 819 13 13-16 | Washer | 194 | 532 19 77-97 | Bearing Control Lever Clutch |
| 38 | 532 19 95-41 | Keeper Belt LH Mandrel | 195 | 817 00 06-12 | Screw 3/8-16 x 3/4 |
| 40 | 873 90 06-00 | Nut, Lock Flg. 3/8-16 unc | 197 | 532 19 78-01 | Spring Plunger Actuator |
| 42 | 532 19 84-10 | Spring Torsion Brake | 199 | 532 40 00-95 | Baffle Vortex |
| 43 | 532 19 72-56 | Spring Torsion Retainer | 209 | 819 13 32-10 | Washer 13/32 x 2 x 10 |
| 46 | 532 13 77-29 | Screw 1/4-20 x 5/8 | -- | 532 19 28-70 | Mandrel Assembly (Includes housing, shaft and shaft hardware only-pulley not included) |
| 55 | 532 19 72-49 | Arm, Idler | -- | 532 40 04-22 | Replacement Mower, Complete |
| 56 | 532 19 90-92 | Spacer, Retainer | | | |
| 57 | 817 00 06-16 | Screw 3/8-16 x 1 | | | |

NOTE: All component dimensions given in U.S. inches
1 inch = 25.4 mm

**TRACTOR - - MODEL NUMBER LTH151 (96041001901), PRODUCT NO. 960 41 00-19
ENGINE**

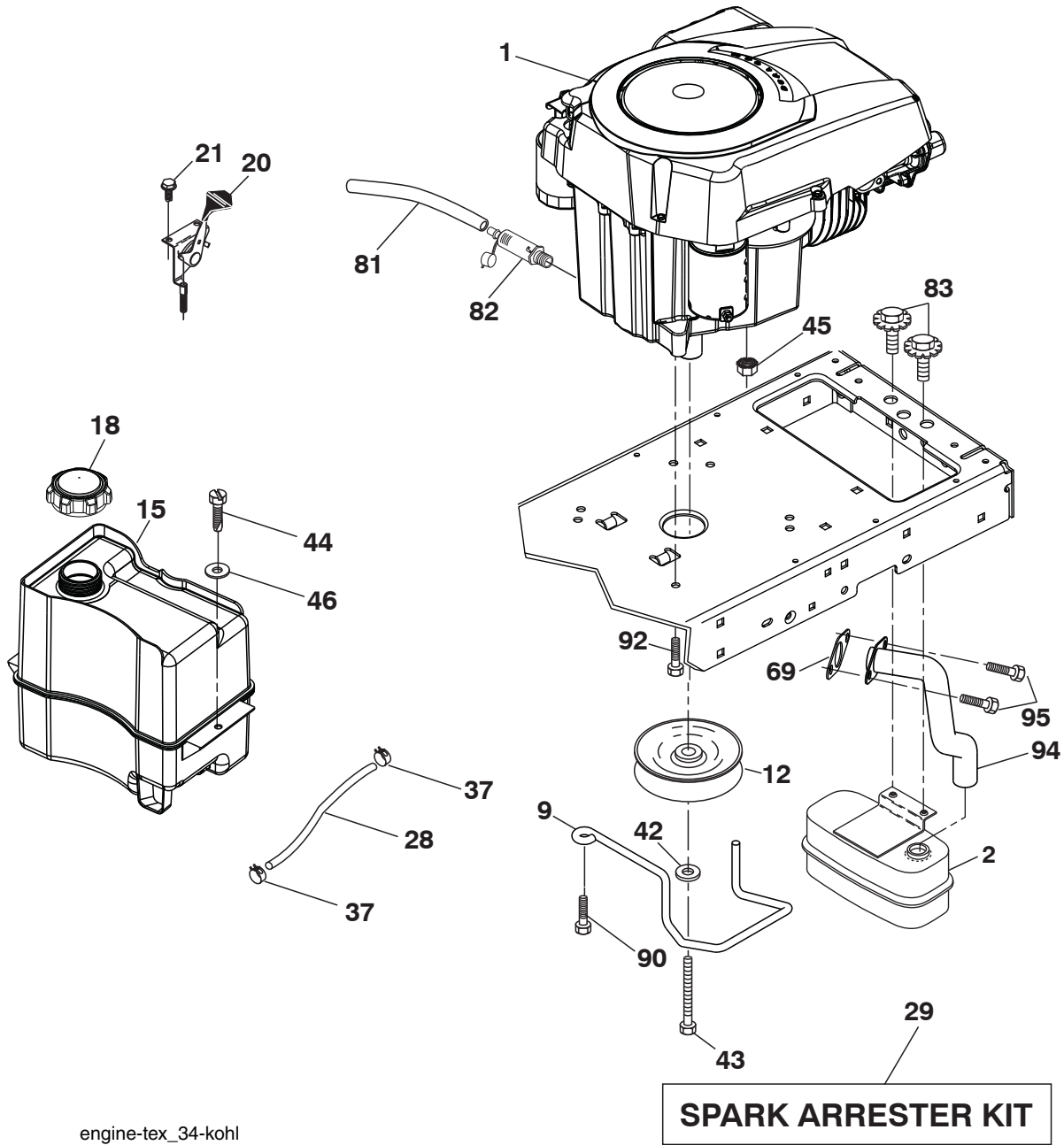

SPARK ARRESTER KIT

engine-tex_34-kohl

| KEY NO. | PART NO. | DESCRIPTION |
|---------|---------------------|--------------------------------|
| 1 | ----- | Engine Kohler Model No. SV470 |
| 2 | 532 18 86-55 | Muffler |
| 9 | 532 19 43-19 | Keeper Belt Engine |
| 12 | 532 40 19-85 | Pulley Engine |
| 15 | 532 40 75-45 | Tank Fuel 1.5 |
| 18 | 532 19 77-25 | Cap Asm |
| 20 | 532 18 38-97 | Control Throttle |
| 21 | 532 19 16-11 | Screw 10 x 3/4 Single Lead-Hex |
| 28 | 532 13 70-40 | Fuel Line |
| 29 | 532 13 71-80 | Spark Arrester Kit |
| 37 | 532 12 34-87 | Clamp Hose |
| 42 | 810 04 07-00 | Washer |

| KEY NO. | PART NO. | DESCRIPTION |
|---------|---------------------|----------------------------------|
| 43 | 532 17 39-37 | Bolt Hex 7/16-20 x 4 Gr. 5 |
| 44 | 817 67 04-12 | Screw Hexwsh Thdrol 1/4-20 x 3/4 |
| 45 | 873 51 04-00 | Nut Keps Hex 1/4-20 unc |
| 46 | 819 09 14-16 | Washer 9/32 x 7/8 x 16 Ga. |
| 69 | ----- | Gasket (Order From Eng. Mfgr.) |
| 81 | 532 14 84-56 | Tube Drain Oil Easy |
| 82 | 532 18 16-54 | Plug Drain Oil |
| 83 | 532 17 18-77 | Bolt 5/16-18 unc x 3/4 w/Sems |
| 90 | 817 00 06-16 | Screw 3/8-16 x 1 |
| 92 | 817 12 06-16 | Screw 3/8-16 x 1 |
| 94 | 532 18 86-54 | Tube Exhaust |
| 95 | 532 19 23-34 | Screw Socket 5/16-18 x .75 |

NOTE: All component dimensions given in U.S. inches
1 inch = 25.4 mm

**TRACTOR - - MODEL NUMBER LTH151 (96041001901), PRODUCT NO. 960 41 00-19
MOWER LIFT**

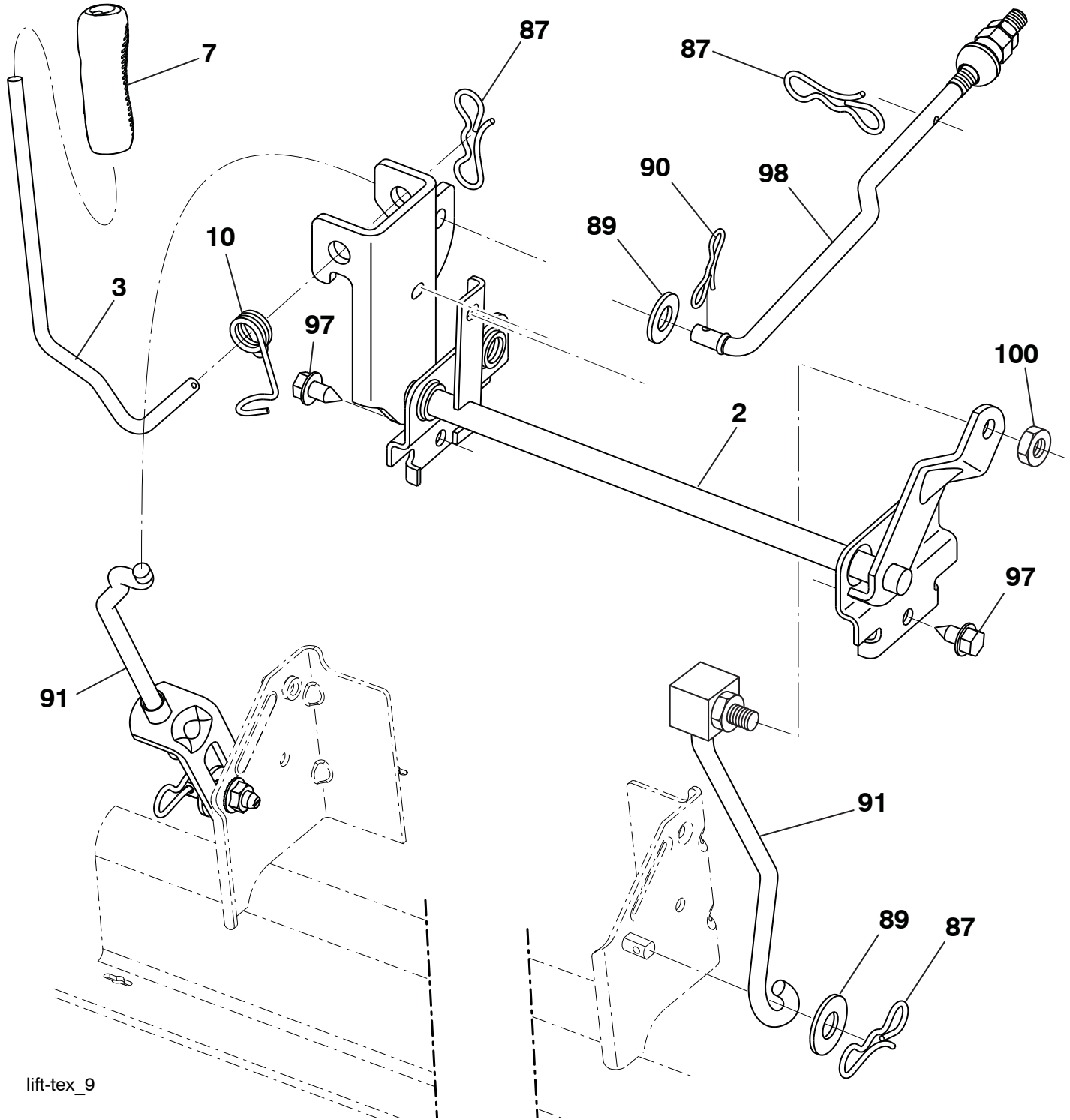

lift-tex_9

| KEY NO. | PART NO. | DESCRIPTION |
|---------|---------------------|------------------------------|
| 2 | 532 19 52-23 | Shaft Asm., Lift |
| 3 | 532 19 52-31 | Lever Asm., Lift Rh |
| 7 | 532 41 15-55 | Grip, Lever |
| 10 | 532 19 63-14 | Spring Torsion |
| 87 | 532 19 42-09 | Pin Cotter 7/16 Bow Tie Lock |
| 89 | 819 19 19-12 | Washer Clear Zinc |
| 90 | 532 19 42-08 | Pin Cotter 5/16 Bow Tie Lock |

| KEY NO. | PART NO. | DESCRIPTION |
|---------|---------------------|----------------------------------|
| 91 | 532 19 51-81 | Link Lift Susp Mower Rear |
| 97 | 817 06 06-12 | Screw 3/8-16 x .75 Smgml Tap/R.Z |
| 98 | 532 19 52-70 | Link Lift Susp. Front Mower |
| 100 | 873 93 06-00 | Nut Centerlock 3/8-16 |

NOTE: All component dimensions given in U.S. inches
1 inch = 25.4 mm

TRACTOR - - MODEL NUMBER LTH151 (96041001901), PRODUCT NO. 960 41 00-19
STEERING ASSEMBLY

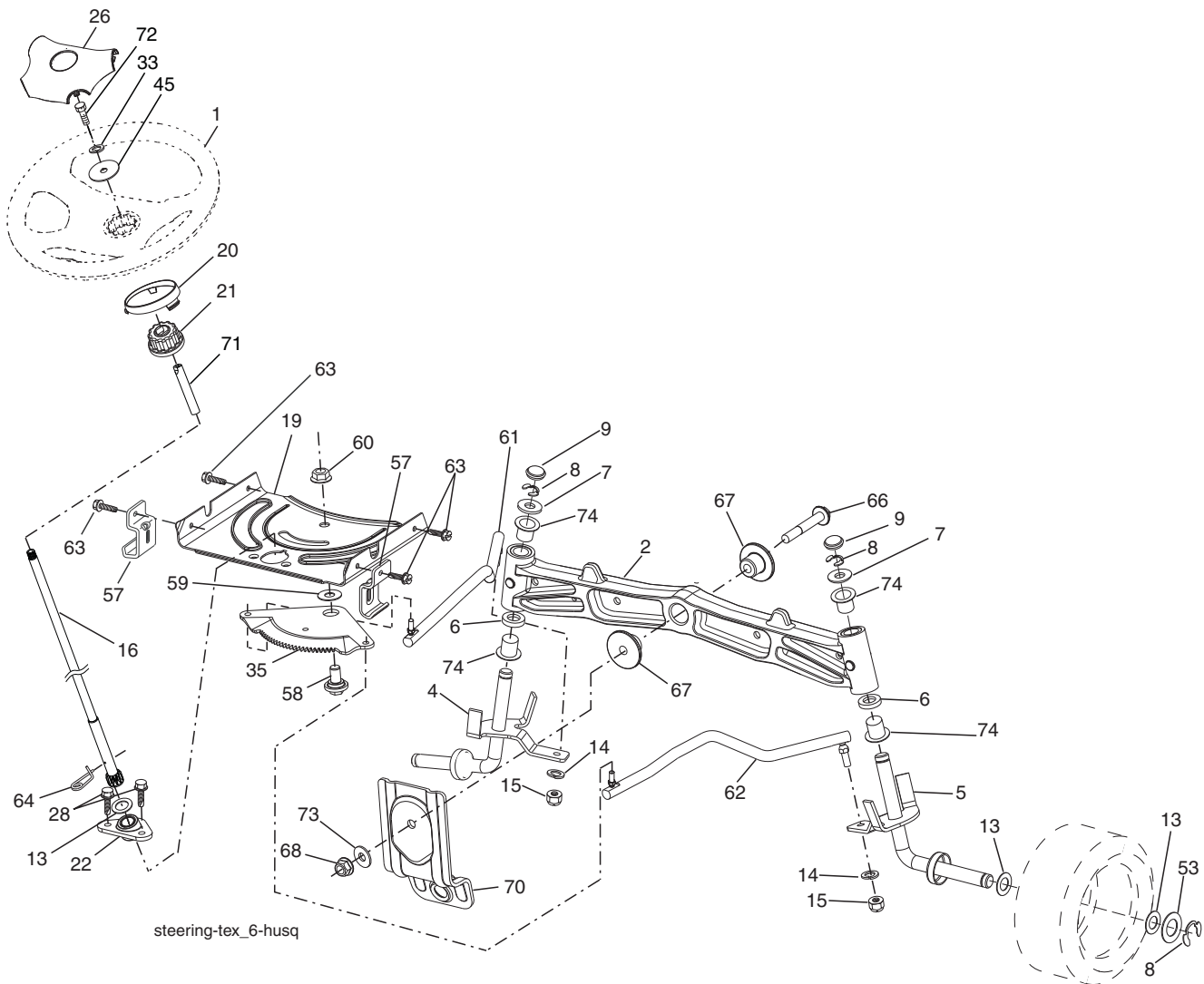

| KEY NO. | PART NO. | DESCRIPTION |
|---------|--------------|--------------------------------|
| 1 | 532 19 36-51 | Wheel, Steering |
| 2 | 532 19 56-73 | Axle Asm., Front |
| 4 | 532 40 30-87 | Spindle Asm., LH |
| 5 | 532 40 30-88 | Spindle Asm., RH |
| 6 | 532 12 49-31 | Bearing, Race Thrust Hardened |
| 7 | 532 12 17-48 | Washer 25/32 x 1-5/8 x 16 Ga. |
| 8 | 812 00 00-29 | Ring, Klip #T5304-75 |
| 9 | 532 12 12-32 | Cap, Spindle |
| 13 | 532 12 17-49 | Washer, 25/32 x 1-1/4 x 16 Ga. |
| 14 | 810 04 06-00 | Washer, Lock Hvy Hlcl Spr 3/8 |
| 15 | 873 54 06-00 | Nut, Crown Lock 3/8-24 unf |
| 16 | 532 19 60-74 | Shaft Steering |
| 19 | 532 19 47-29 | Plate Steering |
| 20 | 532 41 11-39 | Boot, Steering |
| 21 | 532 18 67-37 | Adapter, Wheel Steering |
| 22 | 532 19 48-45 | Bushing, Strg. Blk |
| 26 | 532 19 36-52 | Insert, Wheel Steering |
| 28 | 817 00 06-12 | Screw 3/8-16 x 3/4 |
| 33 | 810 04 05-00 | Washer Lock 5/16 |
| 35 | 532 19 47-32 | Gear, Sector Plate |

| KEY NO. | PART NO. | DESCRIPTION |
|---------|--------------|-------------------------------------|
| 45 | 819 11 38-12 | Washer 11/32 x 3/8 x 12 Ga. |
| 53 | 532 18 89-67 | Washer Hardened .793 x 1.637 x .060 |
| 57 | 532 40 74-65 | Bracket Upstop |
| 58 | 532 19 47-47 | Bolt Shoulder Sector Pivot CFM |
| 59 | 532 19 47-48 | Washer Thrust Sector Steering |
| 60 | 873 97 10-00 | Nut Flange Lock 5/8-11 |
| 61 | 532 19 47-40 | Draglink, LH |
| 62 | 532 19 47-41 | Draglink, RH |
| 63 | 817 00 05-12 | Screw 5/16-18 x 3/4 |
| 64 | 532 19 98-49 | Retainer Clip Spring Steering |
| 66 | 871 02 07-48 | Bolt Hex Fghd 7/16-14 x 3 Serr |
| 67 | 532 19 47-37 | Bushing PM Front Axle |
| 68 | 873 90 07-00 | Nut Lock Flange 7/16-14 Gr. 5 |
| 70 | 532 19 61-97 | Bracket Deck Susp. Front |
| 71 | 532 19 60-75 | Shaft Extension Steering |
| 72 | 874 78 05-72 | Bolt 5/16-18 unc x 4.5. Gr. 5 |
| 73 | 532 19 91-62 | Washer 1.5 x .505 x .118 |
| 74 | 532 12 49-37 | Bearing |

NOTE: All component dimensions given in U.S. inches
 1 inch = 25.4 mm

**TRACTOR - - MODEL NUMBER LTH151 (96041001901), PRODUCT NO. 960 41 00-19
SEAT ASSEMBLY**

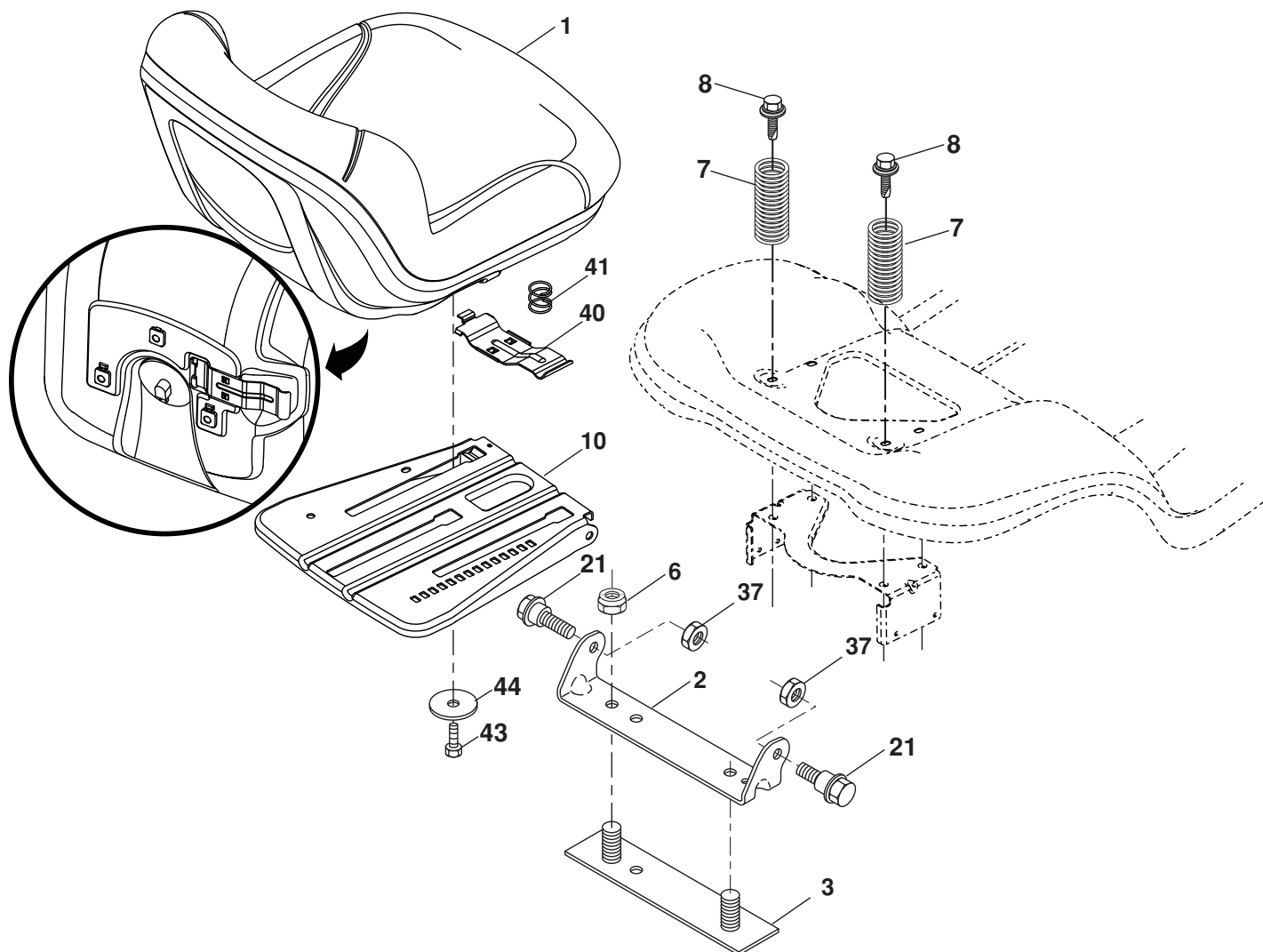

seat-tex_7-vgt

| KEY NO. | PART NO. | DESCRIPTION |
|---------|--------------|-------------------------------|
| 1 | 532 19 75-18 | Seat |
| 2 | 532 18 01-66 | Bracket Pivot Fender |
| 3 | 532 14 06-75 | Strap, Asm Fender |
| 6 | 873 80 06-00 | Nut, Lock W/Ins. 3/8-16 unc |
| 7 | 532 12 41-81 | Spring, Seat Cprsn |
| 8 | 532 17 18-77 | Bolt 5/16-18 unc x 3/4 w/Sems |
| 10 | 532 19 69-77 | Pan, Seat |

| KEY NO. | PART NO. | DESCRIPTION |
|---------|--------------|-------------------------------|
| 21 | 532 17 18-52 | Bolt, Shoulder 5/16-18 |
| 37 | 873 80 05-00 | Nut, Lock 5/16-18 unc |
| 40 | 532 19 76-61 | Handle Slide |
| 41 | 532 19 82-00 | Spring Latch |
| 43 | 874 76 06-12 | Bolt Fin Hex 3/8-16 unc x 3/4 |
| 44 | 819 13 38-12 | Washer 13/32 x 2-3/8 x 12 Ga |

NOTE: All component dimensions given in U.S. inches
1 inch = 25.4 mm