

ILLUSTRATED PARTS LIST

MODEL NO. 96041002001

CUSTOMER CATALOG NO. LTH151

PRODUCT NO. 960 41 00-20

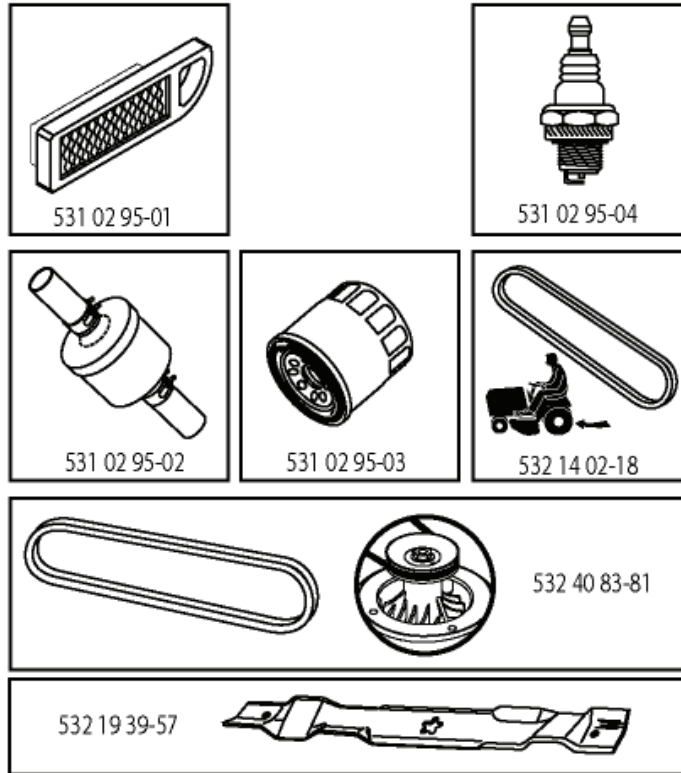

408772

**TRACTOR - - MODEL NUMBER LTH151 (96041002001), PRODUCT NO. 960 41 00-20
DECALS 27**

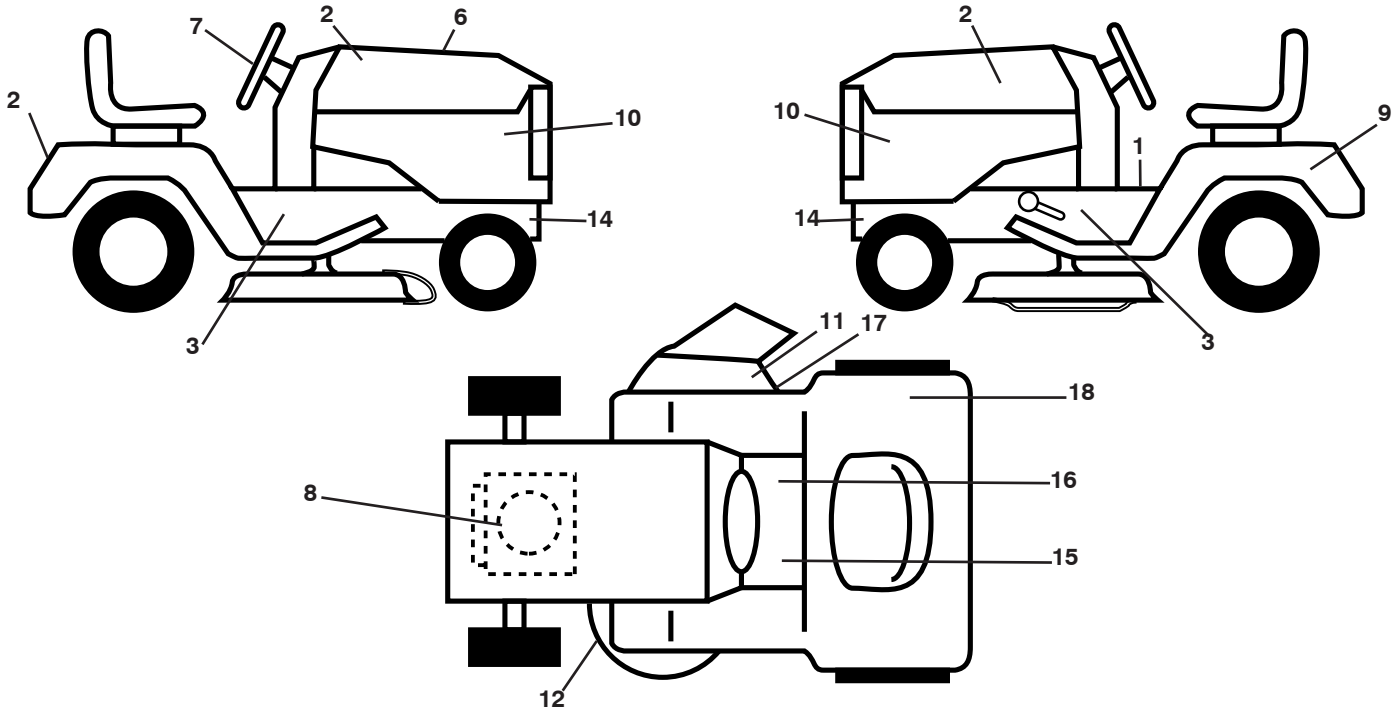

KEY NO.	PART NO.	DESCRIPTION
1	532 40 03-89	Decal, Warning CE
2	532 40 28-32	Decal, Hood/Fender
3	532 19 68-42	Decal, Cutfinger Warning
6	532 40 87-72	Decal, Replacement
7	532 40 44-84	Decal, Steering Wheel
8	532 19 68-41	Decal, Engine
9	532 14 50-05	Decal, Battery Dnge/Poi
10	532 40 85-97	Decal, Side Panel
11	532 18 21-66	Decal, Cutfinger
12	532 19 43-02	Decal, Mower V-Belt Schematic

KEY NO.	PART NO.	DESCRIPTION
14	532 15 97-36	Decal, Hot Muffler
15	532 15 97-37	Decal, Brake/ Clutch Sym.
16	532 14 08-37	Decal, Parking Brake
17	532 19 63-57	Decal, Deflector
18	532 18 04-32	Decal, DB/CE
--	532 16 69-60	Decal, Bypass
--	532 16 25-98	Decal, Load Limit
--	532 41 08-05	Pad, Footrest, LH
--	532 41 10-56	Pad, Footrest, RH
--	532 40 89-59	Manual, Operator's (Euro)

WHEELS AND TIRES

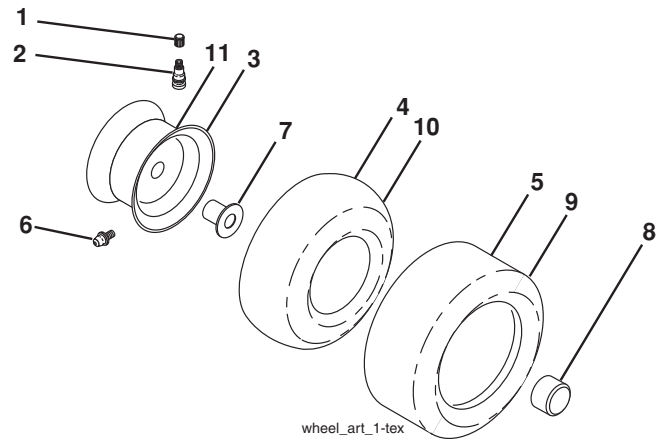

KEY NO.	PART NO.	DESCRIPTION
1	532 05 91-92	Cap Valve Tire
2	532 06 51-39	Stem Valve
3	532 13 83-36	Rim Asm 6" Front Service
4	532 05 99-04	Tube Front (Service Item Only)
5	532 10 62-22	Tire Front 15 x 6.0-6 Service
6	532 12 49-57	Fitting Grease (Front Wheel Only)
7	532 12 49-59	Bearing Flange (Front Wheel Only)
8	532 17 50-39	Cap Axle Blk 1 50 x 1 00
9	532 10 62-68	Tire R T 18 x 9.5-8 Service
10	532 12 49-26	Tube Rear (Service Item Only)
11	532 13 83-37	Rim Asm 8" Rear Service
--	532 14 43-34	Sealant, Tire (10 oz. Tube)

NOTE: All component dimensions given in U.S. inches
1 inch = 25.4 mm

**TRACTOR - - MODEL NUMBER LTH151 (96041002001), PRODUCT NO. 960 41 00-20
SCHEMATIC 38**

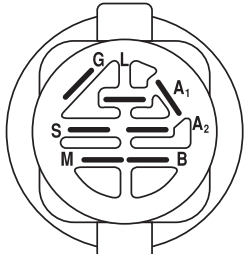
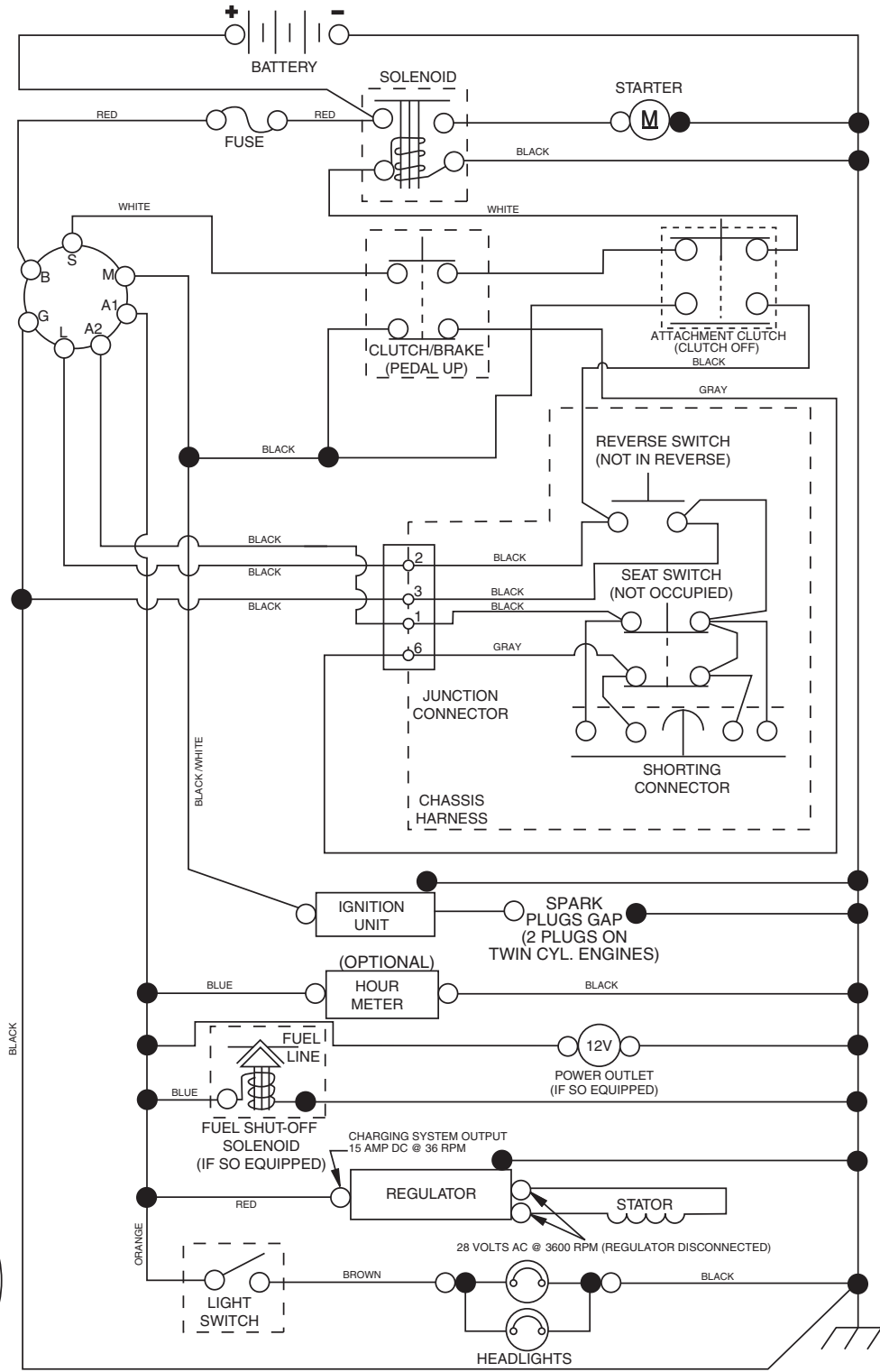

IGNITION SWITCH

POSITION	CIRCUIT	"MAKE"
OFF	M+G+A1	
RUN/OVERRIDE	B+A1	
RUN	B+A1	L+A2
START	B + S + A1	

03101

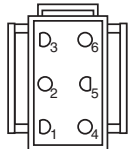

CHASSIS HARNESS CONNECTOR (MATING SIDE)

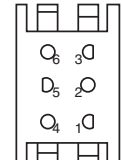

DASH HARNESS CONNECTOR (MATING SIDE)

WIRING INSULATED CLIPS
NOTE: IF WIRING INSULATED CLIPS WERE REMOVED FOR SERVICING OF UNIT, THEY SHOULD BE REPLACED TO PROPERLY SECURE YOUR WIRING.

●
NON-REMOVABLE CONNECTIONS

○
REMOVABLE CONNECTIONS

TRACTOR - - MODEL NUMBER LTH151 (96041002001), PRODUCT NO. 960 41 00-20
ELECTRICAL **32**

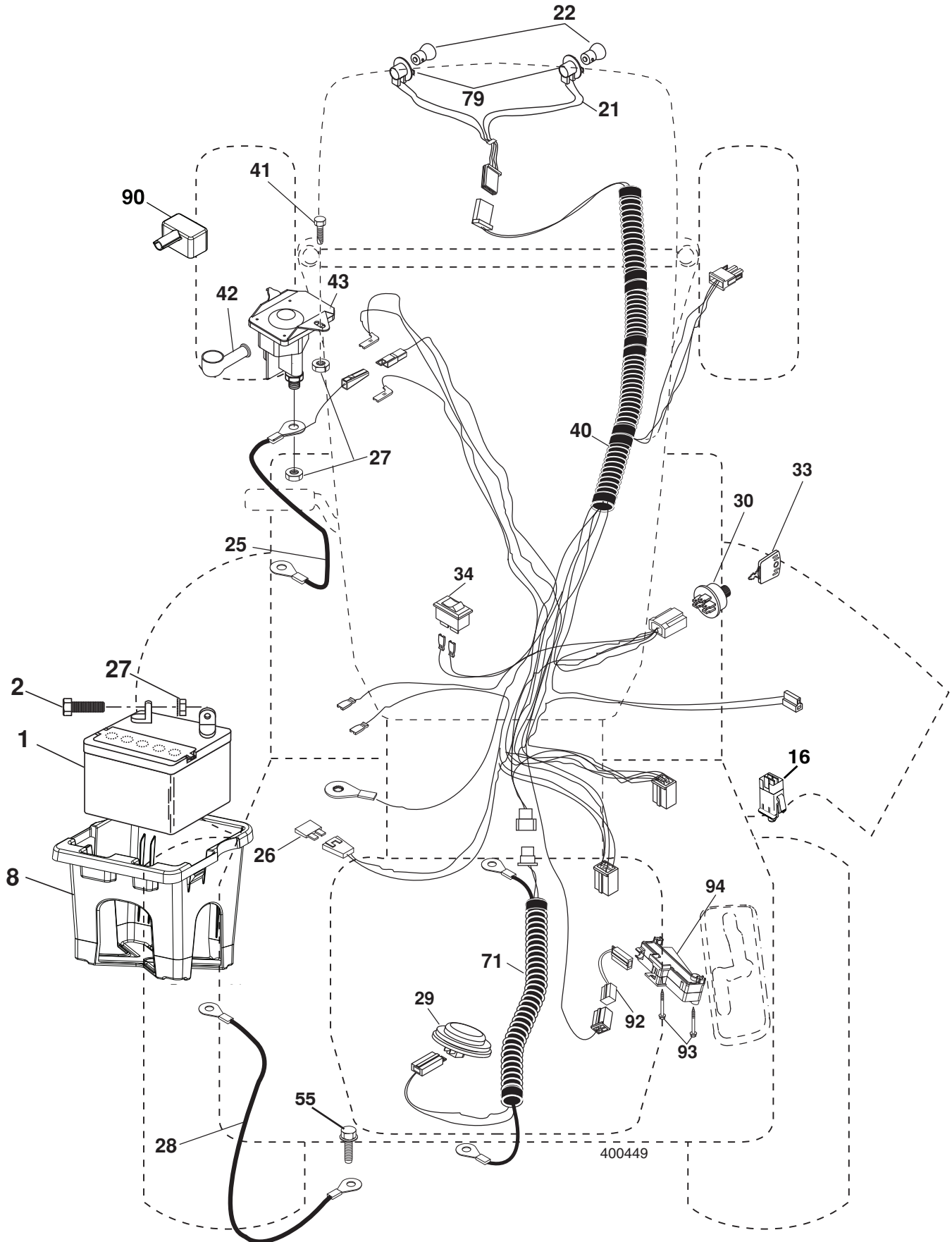

**TRACTOR - - MODEL NUMBER LTH151 (96041002001), PRODUCT NO. 960 41 00-20
ELECTRICAL 32**

KEY NO.	PART NO.	DESCRIPTION
1	532 14 49-27	Battery
2	874 76 04-12	Bolt Hex Head 1/4-20 x 3/4
8	532 19 32-28	Box Battery
16	532 17 61-38	Switch Interlock Push-In
21	532 40 02-52	Harness Socket Light W/4152J
22	532 00 41-52	Bulb Light
25	532 40 16-62	Cable Starter
26	532 17 51-58	Fuse
27	873 51 04-00	Nut Keps Hex 1/4-20 unc
28	532 19 88-85	Cable, Ground
29	532 40 15-45	Switch, Seat
30	532 19 33-50	Switch, Ign
33	532 14 04-01	Key, Ignition
34	532 11 07-12	Switch Light / Reset
40	532 40 10-98	Harness Ign. Dash
41	817 72 04-08	Screw Thd Cut 1/4-20 x 1/2
42	532 13 15-63	Cover, Terminal
43	532 19 25-07	Solenoid
55	817 06 05-12	Screw Thdrol 5/16-18 x 3/4
71	532 40 04-49	Harness Chassis
79	532 17 52-42	Socket Asm Bulb Twistlock
90	532 40 07-25	Cover, Terminal Battery
92	532 19 66-15	Harness Pigtail Reverse Switch
93	532 19 25-40	Screw Plastite 10-14 x 2.0
94	532 19 18-34	Module Reverse ROS

NOTE: All component dimensions given in U.S. inches
1 inch = 25.4 mm

TRACTOR - - MODEL NUMBER LTH151 (96041002001), PRODUCT NO. 960 41 00-20
CHASSIS AND ENCLOSURES **39**

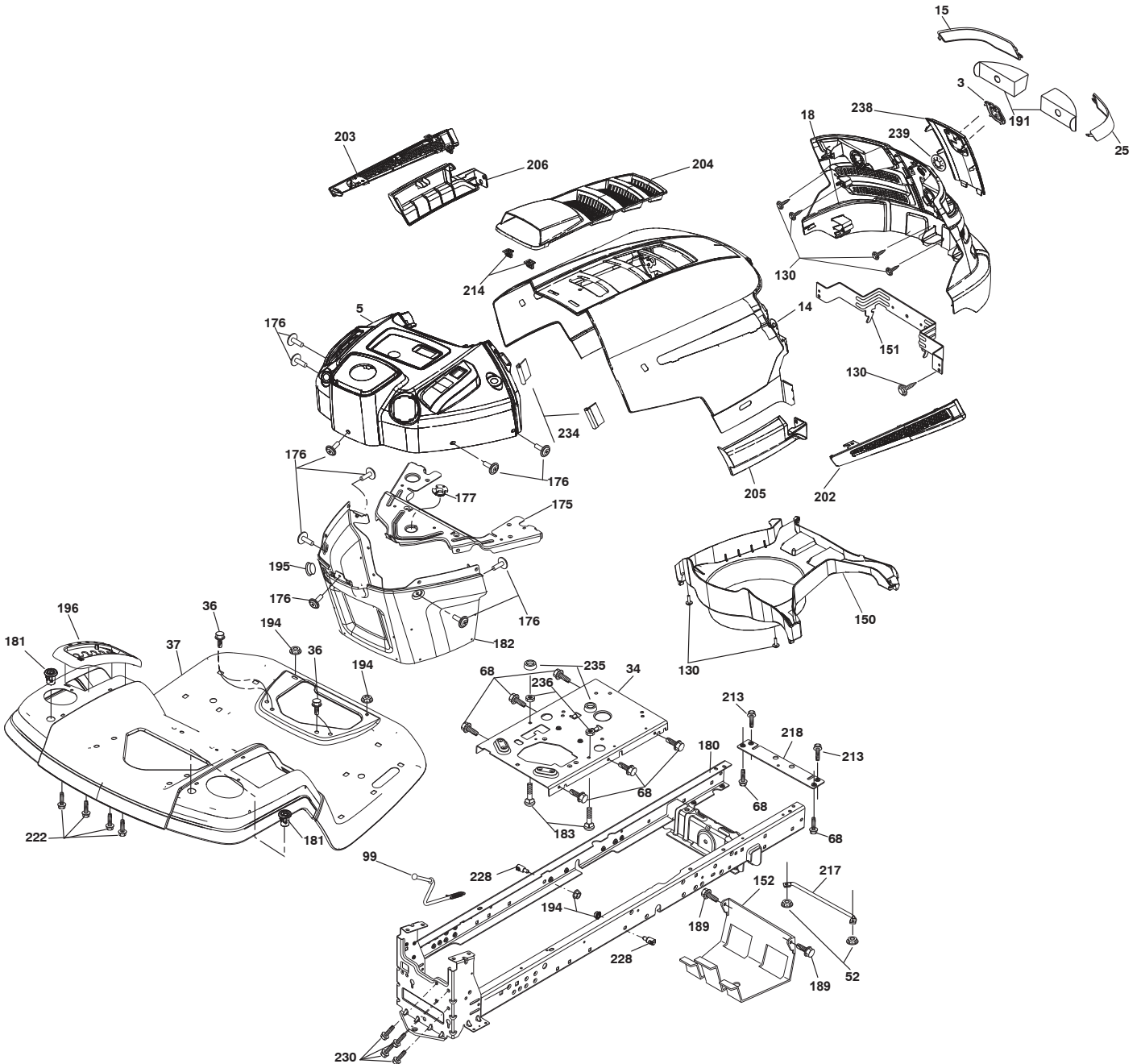

chassis-tex_58-gt-husq

**TRACTOR - - MODEL NUMBER LTH151 (96041002001), PRODUCT NO. 960 41 00-20
CHASSIS AND ENCLOSURES **39****

KEY NO.	PART NO.	DESCRIPTION
3	532 40 50-12	Logo
5	532 40 75-92	Dash
14	532 41 10-73	Hood
15	532 41 10-79	Lens LH
18	532 40 66-67	Grille/Lens Asm.
25	532 41 10-78	Lens RH
34	532 19 61-25	Plate Engine
36	817 06 05-12	Screw 5/16-18 x 3/4
37	532 41 17-67	Fender
52	873 68 05-00	Nut Crown Lock 5/16
68	817 49 05-08	Screw THDROL 5/16-18 x 1/2
99	532 40 33-76	Rod Asm Bypass
130	532 19 16-11	Screw
150	532 40 75-37	Air Duct
151	532 40 78-07	Bracket Pivot
152	532 19 95-35	Shield Browning
175	532 19 94-72	Crossmember
176	532 40 07-76	Screw 10-24 x 5/8
177	532 19 52-28	Bushing Steering
180	532 19 54-57	Chassis
181	532 40 30-25	Bushing Mtg. Fender Crgo
182	532 19 89-17	Dash Lower
183	874 78 05-20	Bolt 5/16-18 unc x 1-1/4
189	817 00 05-12	Screw 5/16-18 x 3/4
191	532 40 66-65	Insert Reflective
194	873 90 05-00	Nut Lock Hex Flange 5/16-18
195	532 41 11-15	Plug Dash
196	532 40 28-43	Console Asm. Deck Lift
202	532 41 10-74	Vent Side Hood RH
203	532 41 10-75	Vent Side Hood LH
204	532 41 11-16	Vent Top Hood
205	532 41 10-76	Skirt Side RH
206	532 41 10-77	Skirt Side LH
213	874 76 05-12	Bolt 5/16-18 x 3/4
214	532 19 91-45	Clip Retainer
217	532 40 91-67	Rod Pivot Hood
218	532 19 63-95	X-Piece Hood Stop
222	532 13 77-29	Screw 1/4-20 x 5/8
228	532 19 51-61	Stud Fastener
230	532 17 01-65	Bolt Shoulder 5/16-18
234	532 40 47-42	Bumper Hood
235	532 40 61-29	Spacer Fender
236	873 93 05-00	Nut Lock 5/16-18 unc
238	532 41 11-19	Trim
239	532 40 48-83	Clip Tinnerman

NOTE: All component dimensions given in U.S. inches
1 inch = 25.4 mm

TRACTOR - - MODEL NUMBER LTH151 (96041002001), PRODUCT NO. 960 41 00-20
DRIVE **40**

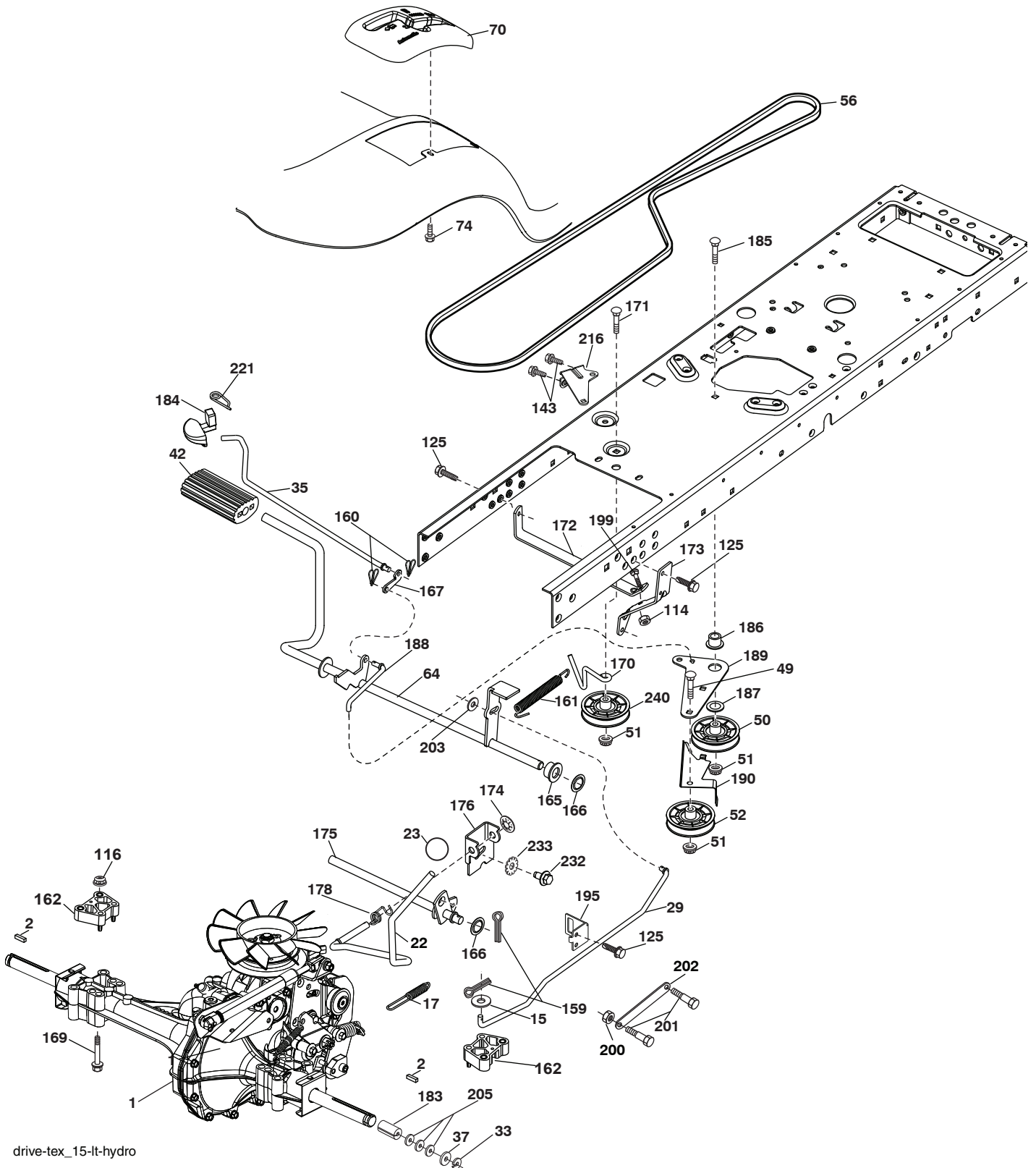

drive-tex_15-lt-hydro

**TRACTOR - - MODEL NUMBER LTH151 (96041002001), PRODUCT NO. 960 41 00-20
DRIVE **40****

KEY NO.	PART NO.	DESCRIPTION	KEY NO.	PART NO.	DESCRIPTION
1	-----	Transaxle, Hydro 351-0510 (Order Parts from Transaxle Manufacturer)	167	532 40 52-57	Latch Brake Parking
2	532 12 35-83	Key	169	874 49 05-60	Bolt 5/16-18 x 3.75
15	819 13 13-16	Washer 13/32 x 13/16 x 16 Ga.	170	532 19 43-22	Keeper Belt Centerspan
17	532 19 72-96	Spring, Brake	171	872 11 06-22	Bolt
22	532 19 76-60	Rod Shift	172	532 19 76-56	Strap Torque LH
23	532 12 12-74	Knob	173	532 19 76-55	Strap Torque RH
29	532 19 76-59	Rod, Brake	174	532 19 72-89	Nut Push
33	812 00 00-01	Ring E	175	532 19 76-53	Shaft Asm
35	532 40 10-31	Rod, Brake, Park	176	532 19 62-14	Asm Clevis Rod Shift
37	532 12 17-49	Washer 25/32 x 1-1/4 x 16 Ga.	178	532 19 74-56	Spring Shift
42	532 12 48-72	Cover, Foot Pedal	183	532 13 70-57	Spacer Axle
49	872 11 06-14	Bolt	184	532 40 97-47	Handle Parking Brake
50	532 19 43-27	Pulley Idler Flat	185	872 11 06-20	Bolt
51	873 90 06-00	Lock Nut 3/8-16	186	532 19 43-21	Spacer Retainer
52	532 19 43-26	Idler V-Groove 910" Offset	187	819 13 32-10	Washer
56	532 14 02-18	V-Belt, Drive	188	532 19 43-23	Link Clutch Ground Drive
64	532 19 62-00	Shaft Asm. Pedal Brake Control	189	532 19 43-17	Bellcrank Ground Drive
70	532 41 14-74	Console Shift	190	532 19 43-18	Keeper Bellcrank Ground Drive
74	532 14 24-32	Screw Hex WSH Hi-Lo 1/4 x 1/2 unc	195	532 19 80-12	Bracket Rod Brake
114	873 80 05-00	Nut Lock Hex W/INS 5/16-18 unc	199	872 14 05-08	Bolt RDHD SQNK 5/16-18 unc x 1
116	873 90 05-00	Nut Lock Hex Flange 5/16-18	200	873 93 05-00	Nut Center Lock 5/16-18 unc
125	817 00 05-12	Screw 5/16-18 x 3/4	201	532 16 96-12	Bolt Shoulder 5/16-18 unc
143	817 49 05-08	Screw 5/16-18 x 1/2	202	532 19 77-15	Link Trans
159	876 02 04-12	Pin Cotter 1/8 x 3/4	203	819 11 11-16	Washer 11/32 x 11/16 x 16 Ga.
160	532 16 94-84	Retainer Clip	205	532 12 17-48	Washer 25/32 x 1-5/8 x 16 Ga.
161	532 19 54-03	Spring, Return, Clutch	216	532 19 61-31	Bracket Pulley
162	532 19 57-85	Spacer Transaxle	221	532 40 31-87	Retainer Spring Clip Handle
165	532 19 62-12	Bushing	232	874 78 07-16	Bolt 7/16-14 x 1
166	532 19 72-90	Nut Push .625	233	532 40 52-96	Washer Serrated
			240	532 40 72-87	Pulley V-Groove

NOTE: All component dimensions given in U.S. inches
1 inch = 25.4 mm

TRACTOR - - MODEL NUMBER LTH151 (96041002001), PRODUCT NO. 960 41 00-20
MOWER DECK **44**

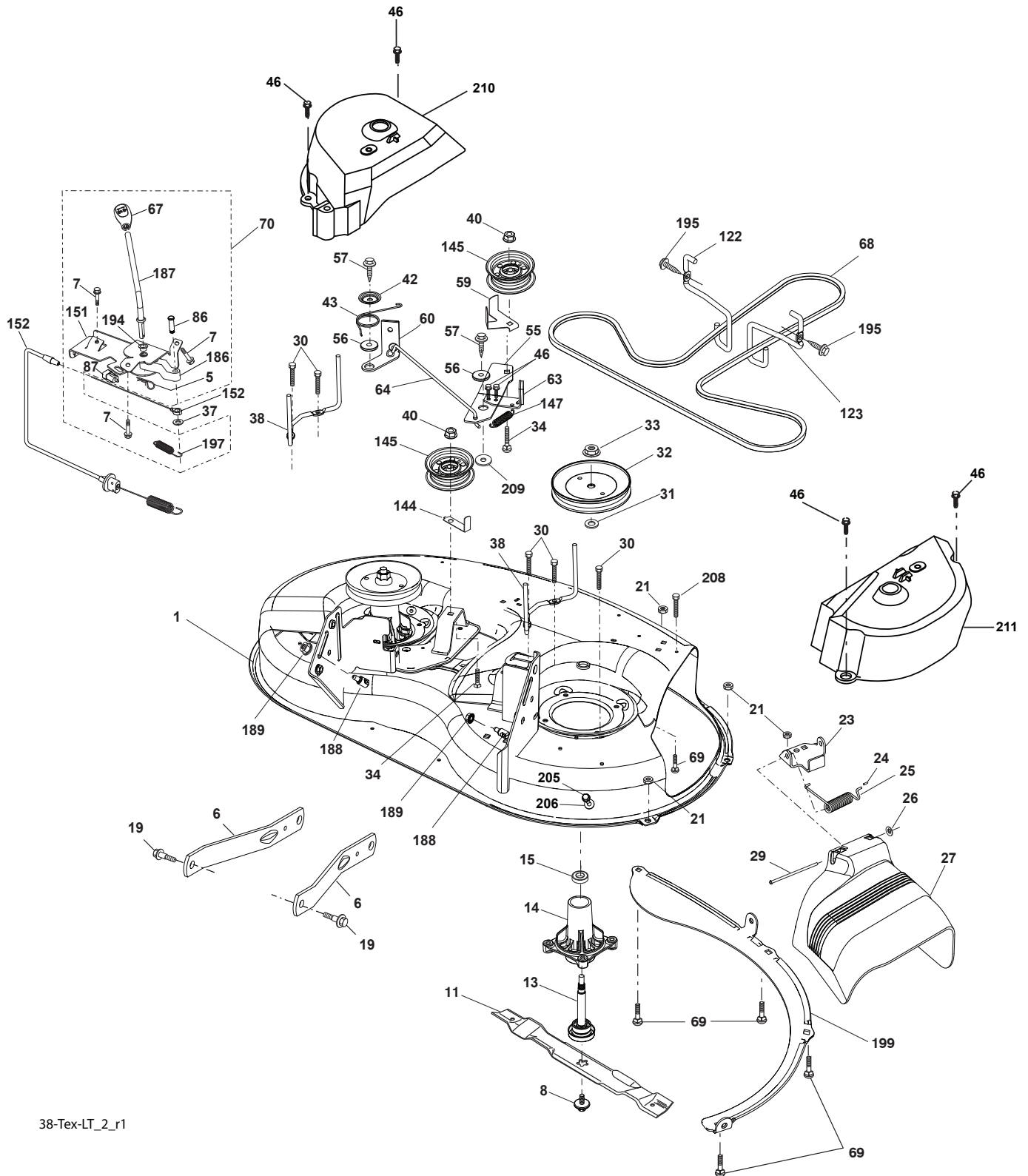

38-TeX-LT_2_r1

**TRACTOR - - MODEL NUMBER LTH151 (96041002001), PRODUCT NO. 960 41 00-20
MOWER DECK **44****

KEY NO.	PART NO.	DESCRIPTION	KEY NO.	PART NO.	DESCRIPTION
1	532 19 42-51	Mower Housing	67	532 40 30-12	Handle Clutch Cable
5	532 12 46-70	Retainer Spring	68	532 40 83-81	V-Belt
6	532 19 51-86	Arm Suspension	69	872 14 05-05	Bolt
7	532 19 16-11	Screw 10 x 3/4 Single Lead Hex	70	532 40 12-46	Clutch Asm Manual
8	532 19 30-03	Bolt/Washer asm 7/16-20 unf	86	532 19 77-98	Pin Attachment Cable
11	532 19 39-57	Blade	87	532 19 78-02	Switch Interlock Clutch Cable
13	532 19 28-72	Shaft Assembly, Mandrel	122	532 19 72-58	Keeper Belt Engine LH
14	532 18 72-81	Housing, Mandrel	123	532 19 72-59	Keeper Belt Engine RH
15	532 11 04-85	Bearing, Ball, Mandrel	144	532 19 34-14	Keeper Belt
19	532 19 65-39	Bolt, Shoulder	145	532 19 31-97	Pulley Idler
21	873 68 05-00	Nut, Crownlock 5/16-18 unc	147	532 40 18-72	Spring Return
23	532 19 25-57	Bracket, Deflector	151	532 40 12-44	Bracket
24	532 10 53-04	Cap, Sleeve	152	532 40 87-14	Manual Clutch Cable
25	532 19 70-26	Spring, Torsion, Deflector	186	532 19 77-99	Arm Actuator
26	532 11 04-52	Nut, Push	187	532 40 12-45	Lever Control Clutch
27	532 40 16-18	Shield, Deflector	188	532 19 51-61	Stud Fastener
29	532 13 14-91	Rod, Hinge	189	873 90 05-00	Nut Lock Hex Flange
30	532 17 39-84	Screw Thdrol Rolling Wsh Hd	194	532 19 77-97	Bearing Control Lever Clutch
31	532 18 76-90	Washer, Spacer	195	817 00 06-12	Screw 3/8-16 x 3/4
32	532 19 97-89	Pulley, Mandrel	197	532 19 78-01	Spring Plunger Actuator
33	532 40 02-34	Nut, Toplock, Flanged	199	532 40 00-95	Baffle Vortex
34	872 11 06-12	Bolt Carr Sh. 3/8-16 x 1-1/2 Gr. 5	205	817 49 04-16	Screw 1/4-20 x 1.00
37	819 13 13-16	Washer	206	819 09 14-16	Washer 9/32 x 7/8 x 16 Ga.
38	532 19 95-41	Keeper Belt LH Mandrel	208	817 67 06-08	Screw 3/8-16 x 1/2
40	873 90 06-00	Nut, Lock Flg. 3/8-16 unc	209	819 13 32-10	Washer 13/32 x 2 x 10
42	532 19 84-10	Spring Torsion Brake	210	532 40 92-56	Cover Mandrel LH
43	532 19 72-56	Spring Torsion Retainer	211	532 40 92-57	Cover Mandrel RH
46	532 13 77-29	Screw	--	532 19 28-70	Mandrel Assembly (Includes housing, shaft and shaft hardware only-pulley not included)
55	532 19 72-49	Arm, Idler	--	532 40 86-77	Replacement Mower, Complete
56	532 19 90-92	Spacer, Retainer			
57	817 00 06-16	Screw 3/8-16 x 1			
59	532 14 10-43	Guard, Tuv Idler			
60	532 19 94-71	Arm Brake Mower			
63	532 19 94-70	Arm Brake Mower			
64	532 19 97-90	Link Brake			

NOTE: All component dimensions given in U.S. inches
1 inch = 25.4 mm

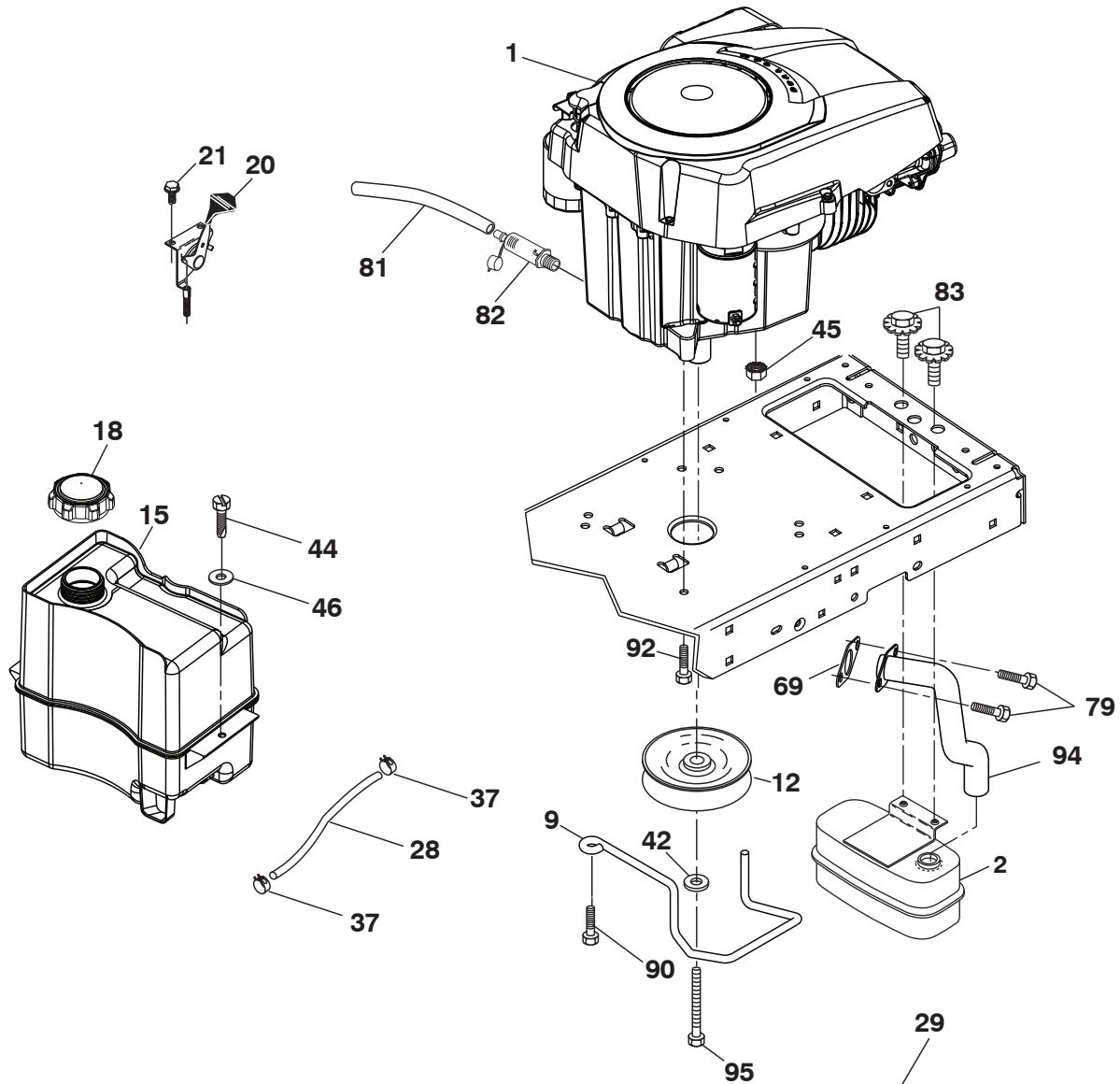

SPARK ARRESTER KIT

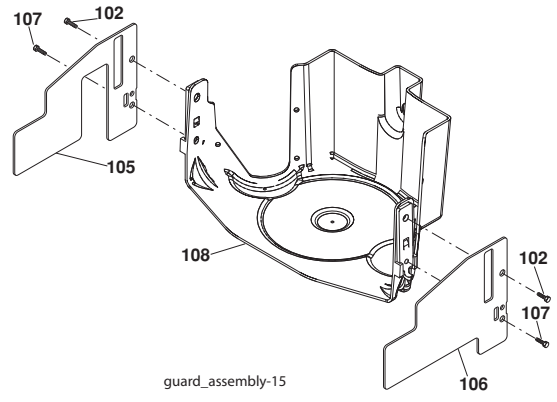

engine-tex_35-kohl

guard_assembly-15

**TRACTOR - - MODEL NUMBER LTH151 (96041002001), PRODUCT NO. 960 41 00-20
ENGINE 24**

KEY NO.	PART NO.	DESCRIPTION
1	-----	Engine Kohler Model No. SV470
2	532 18 86-55	Muffler
9	532 19 43-19	Keeper Belt Engine
12	532 40 19-85	Pulley Engine
15	532 40 75-45	Tank Fuel
18	532 19 77-25	Cap Asm
20	532 18 38-97	Control Throttle
21	532 19 16-11	Screw 10 x 3/4 Single Lead-Hex
28	532 13 70-40	Fuel Line
29	532 13 71-80	Spark Arrester Kit
37	532 12 34-87	Clamp Hose
42	810 04 07-00	Washer Lock 7/16
44	817 67 04-12	Screw Hexwsh Thdrol 1/4-20 x 3/4
45	873 51 04-00	Nut Keps Hex 1/4-20 unc
46	819 09 14-16	Washer 9/32 x 7/8 x 16 Ga.
69	532 18 59-09	Gasket
79	532 19 23-34	Screw Socket HD 5/16-18 x .75
81	532 14 84-56	Tube Drain Oil Easy
82	532 18 16-54	Plug Drain Oil
83	532 17 18-77	Bolt 5/16 - 18 x 3/4 w/Sems
90	817 00 06-16	Screw 3/8-16 x 1
92	817 12 06-16	Screw 3/8-16 x 1
94	532 18 86-54	Tube Exhaust
95	532 17 39-37	Bolt 7/16 - 20 x 4 Gr. 5
102	817 00-05-12	Screw
105	532 41 05-28	Shield Side LH
106	532 41 05-29	Shield Side RH
107	532 13 77-29	Screw
108	532 41 05-32	Cover Asm Engine

NOTE: All component dimensions given in U.S. inches
1 inch = 25.4 mm

**TRACTOR - - MODEL NUMBER LTH151 (96041002001), PRODUCT NO. 960 41 00-20
SEAT ASSEMBLY 42**

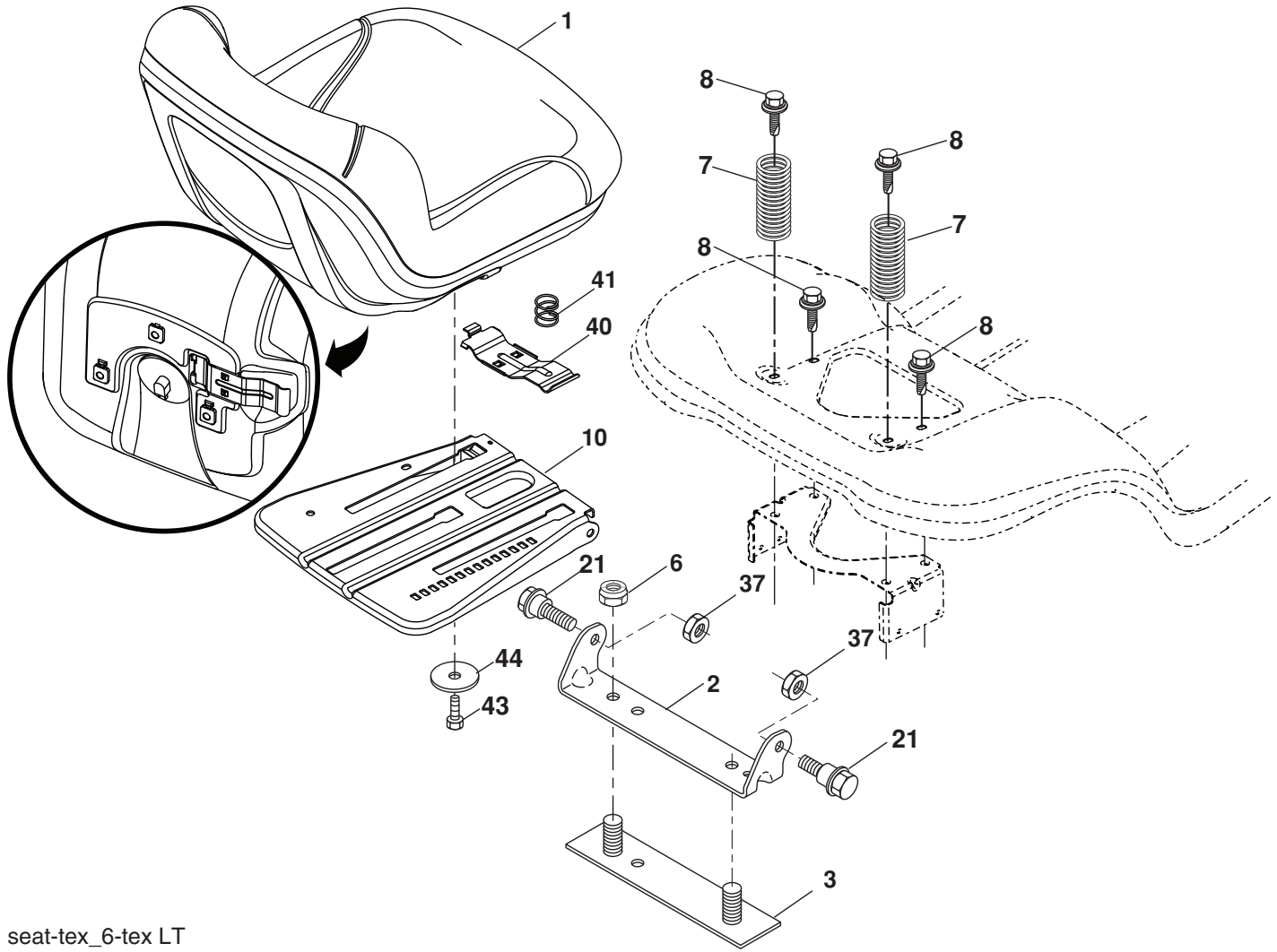

seat-tex_6-tex LT

KEY NO.	PART NO.	DESCRIPTION
1	532 19 75-18	Seat
2	532 18 01-66	Bracket Pivot Fender
3	532 14 06-75	Strap, Asm Fender
6	873 80 06-00	Nut, Lock W/Ins. 3/8-16 unc
7	532 12 41-81	Spring, Seat Cprsn
8	532 17 18-77	Bolt 5/16-18 unc x 3/4 w/Sems
10	532 19 69-77	Pan, Seat

KEY NO.	PART NO.	DESCRIPTION
21	532 17 18-52	Bolt, Shoulder 5/16-18
37	873 80 05-00	Nut, Lock 5/16-18 unc
40	532 19 76-61	Handle Slide Seat
41	532 19 82-00	Spring Latch Seat
43	874 76 06-12	Bolt Fin Hex 3/8-16 unc x 3/4
44	819 13 38-12	Washer 13/32 x 2-3/8 x 12 Ga.

NOTE: All component dimensions given in U.S. inches
1 inch = 25.4 mm

**TRACTOR - - MODEL NUMBER LTH151 (96041002001), PRODUCT NO. 960 41 00-20
STEERING ASSEMBLY 41**

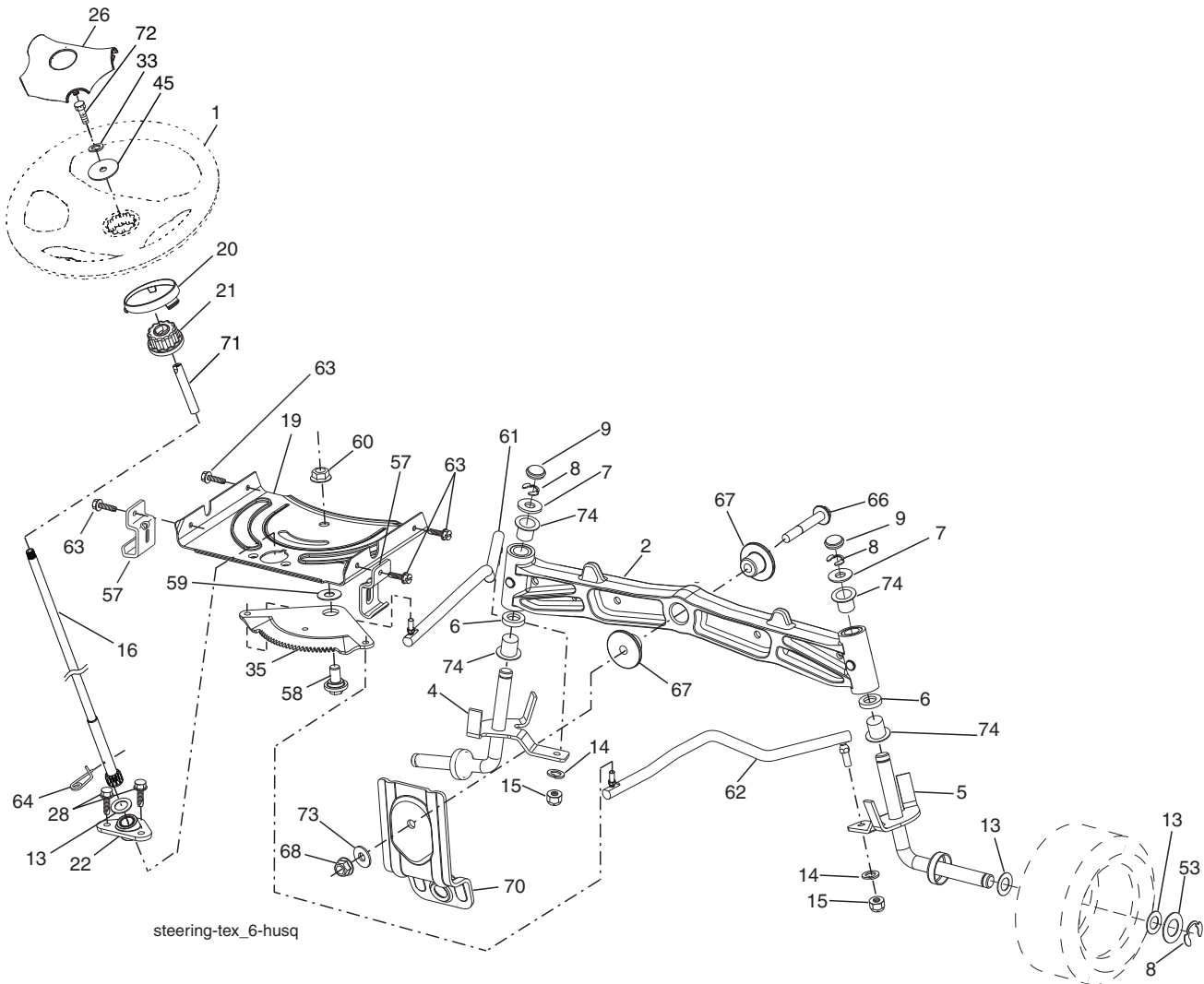

KEY NO.	PART NO.	DESCRIPTION
1	532 19 36-51	Wheel, Steering
2	532 19 56-73	Axle Asm., Front
4	532 40 30-87	Spindle Asm., LH
5	532 40 30-88	Spindle Asm., RH
6	532 12 49-31	Bearing, Race Thrust Hardened
7	532 12 17-48	Washer 25/32 x 1-5/8 x 16 Ga.
8	812 00 00-29	Ring, Klip #T5304-75
9	532 12 12-32	Cap, Spindle
13	532 12 17-49	Washer 25/32 x 1-1/4 x 16 Ga.
14	810 04 06-00	Washer, Lock Hvy Hlcl Spr 3/8
15	873 54 06-00	Nut, Crown Lock 3/8-24 unf
16	532 19 60-74	Shaft Steering
19	532 19 47-29	Plate Steering
20	532 41 11-39	Boot, Steering
21	532 18 67-37	Adapter, Wheel Steering
22	532 19 48-45	Bushing, Strg. Blk
26	532 19 36-52	Insert, Wheel Steering
28	817 00 06-12	Screw 3/8-16 x 3/4
33	810 04 05-00	Washer Lock 5/16

KEY NO.	PART NO.	DESCRIPTION
35	532 19 47-32	Gear, Sector Plate
45	819 11 38-12	Washer 11/32 x 3/8 x 12 Ga.
53	532 18 89-67	Washer Hardened .793 x 1.637 x .060
57	532 40 74-65	Bracket Upstop
58	532 19 47-47	Bolt Shoulder Sector Pivot CFM
59	532 19 47-48	Washer Thrust Sector Steering
60	873 97 10-00	Nut Flange Lock 5/8-11
61	532 19 47-40	Draglink, LH
62	532 19 47-41	Draglink, RH
63	817 00 05-12	Screw 5/16-18 x 3/4
64	532 19 98-49	Retainer Clip Spring Steering
66	871 02 07-48	Bolt Hex Fghd 7/16-14 x 3 Serr
67	532 19 47-37	Bushing PM Front Axle
68	873 90 07-00	Nut Lock Flange 7/16-14 Gr. 5
70	532 19 61-97	Bracket Deck Susp. Front
71	532 19 60-75	Shaft Extension Steering
72	874 78 05-72	Bolt 5/16-18 unc x 4.5. Gr. 5
73	532 19 91-62	Washer 1.5 x .505 x .118
74	532 12 49-37	Bearing

NOTE: All component dimensions given in U.S. inches
1 inch = 25.4 mm

TRACTOR - - MODEL NUMBER LTH151 (96041002001), PRODUCT NO. 960 41 00-20
 MOWER LIFT **45**

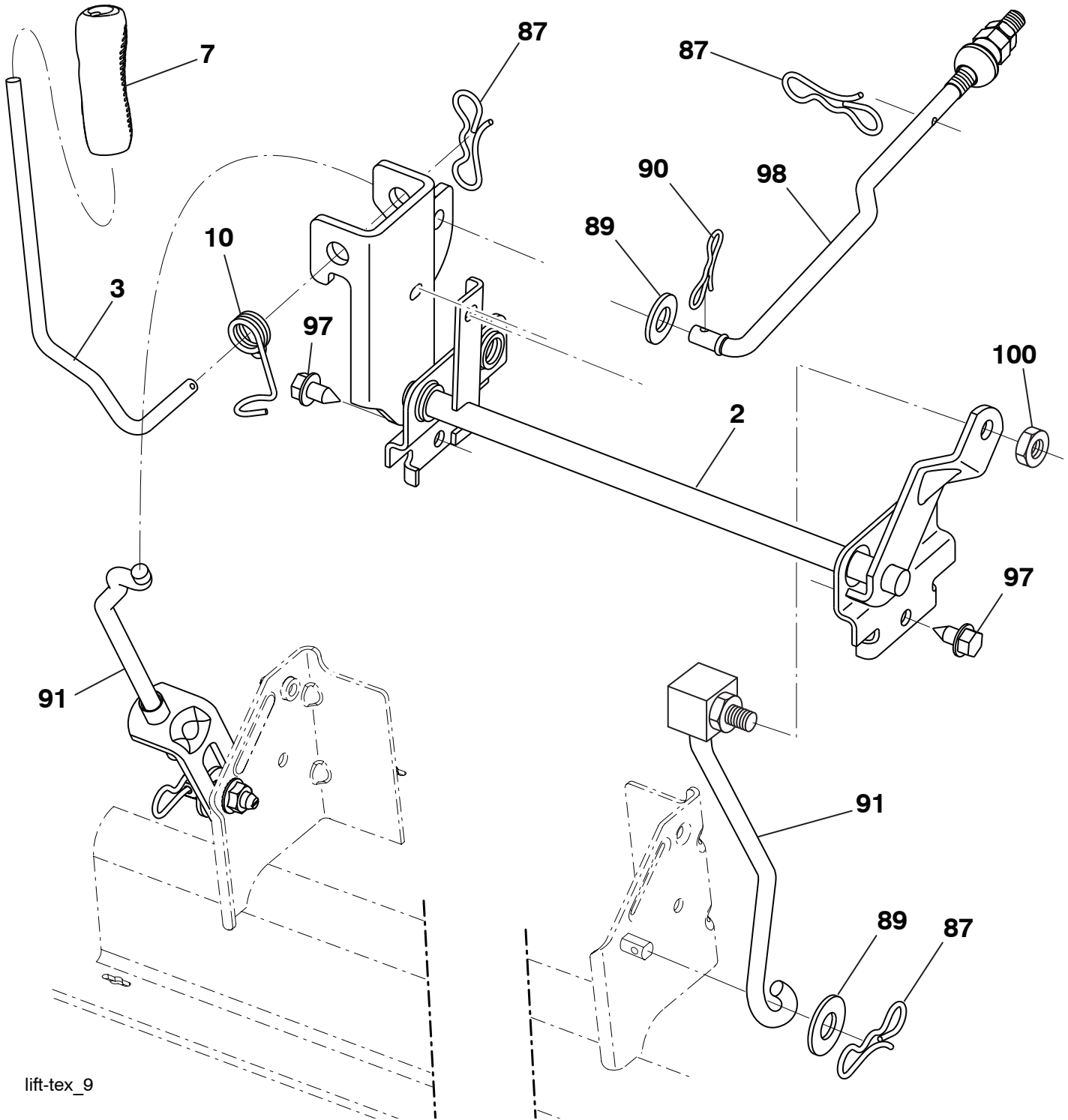

lift-tex_9

KEY NO.	PART NO.	DESCRIPTION
2	532 19 52-23	Shaft Asm., Lift
3	532 19 52-31	Lever Asm., Lift Rh
7	532 41 15-55	Grip, Lever
10	532 19 63-14	Spring Torsion
87	532 19 42-09	Pin Cotter 7/16 Bow Tie Lock
89	819 19 19-12	Washer Clear Zinc
90	532 19 42-08	Pin Cotter 5/16 Bow Tie Lock

KEY NO.	PART NO.	DESCRIPTION
91	532 19 51-81	Link Asm Lift LH Rear
97	817 06 06-12	Screw 3/8-16 x .75 Smgml Tap/R.Z
98	532 19 52-70	Link Lift Susp. Front Mower
100	873 93 06-00	Nut Hex Jam ASF 7/16-20 unf

NOTE: All component dimensions given in U.S. inches
 1 inch = 25.4 mm

