

CTH180 Twin

Spare parts

Ersatzteile

Pièces détachées

Reserve onderdelen

Repuestos

Reservdelar

ILLUSTRATED PARTS LIST

MODEL NO. 96061018601

CUSTOMER CATALOG NO. CTH180TWIN

PRODUCT NO. 960 61 01-86

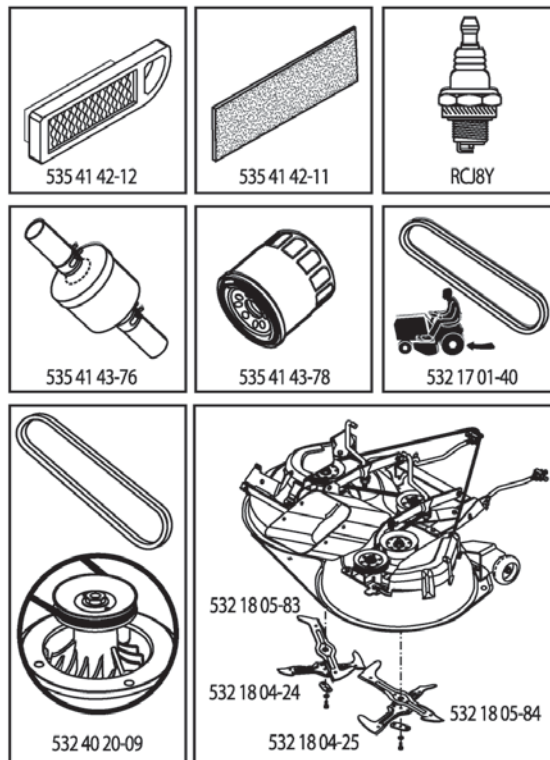

409661

**TRACTOR - - MODEL NO. CTH180TWIN (96061018601), PRODUCT NO. 960 61 01-86
DECALS**

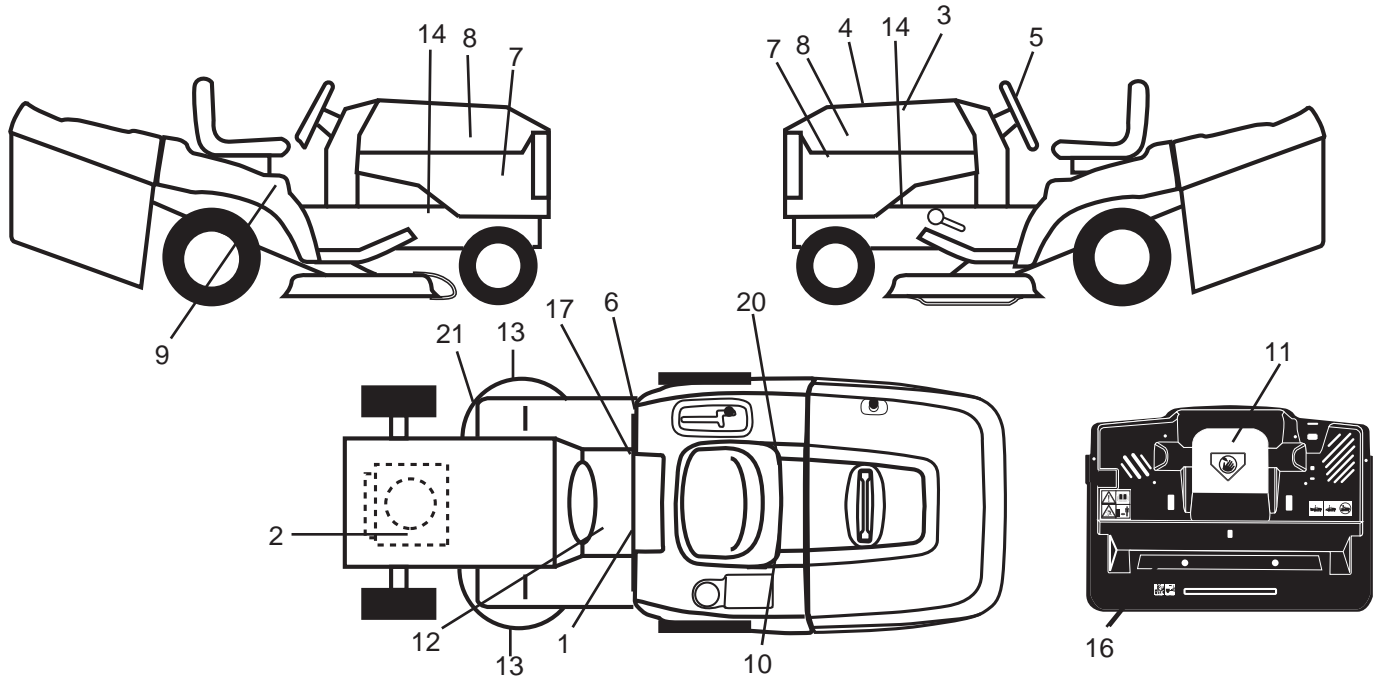

KEY NO.	PART NO.	DESCRIPTION
1	532 40 03-89	Decal, Warning Sym. CE
2	532 19 68-41	Decal, Engine Wrng Symbols
3	532 40 21-28	Decal, Hood Top Insert
4	532 40 96-61	Decal, Replacement
5	532 40 44-84	Decal, Wheel Steering
6	532 18 04-32	Decal, 100 DB/CE
7	532 40 96-40	Decal, Panel Side
8	532 40 28-32	Decal, Hood
9	532 18 04-32	Decal, Fender Logo
10	532 14 50-05	Decal, Bat Dan/Poi P/L Sym Wpn
11	532 18 21-66	Decal, Mower Cut Finger Symbol
12	532 15 97-37	Decal, Brake/Clutch Symbol Lt

KEY NO.	PART NO.	DESCRIPTION
13	532 19 68-42	Decal, SDL SHF/CRD Sym Cutfng
14	532 15 97-36	Decal, Chassis Hot Muffler
16	532 18 04-35	Decal, Backplate
17	532 14 08-37	Decal, Saddle Brake Parking
20	532 16 69-60	Decal, Bypass Fender CRD
21	532 16 62-86	Decal, Hex Belt Sch 92 CRD
--	532 18 19-17	Pad Footrest RH
--	532 18 19-16	Pad Footrest LH
--	532 40 91-31	Manual Operator's (Euro)
--	532 40 91-32	Manual Operator's (Scan)
--	532 40 91-33	Manual Operator's (E-Bloc)
--	532 40 91-34	Manual Operator's (Baltic)

WHEELS & TIRES

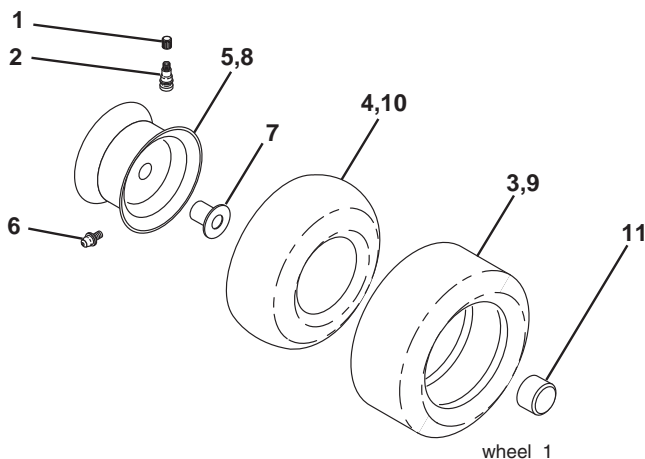

KEY NO.	PART NO.	DESCRIPTION
1	532 05 91-92	Cap Valve Tire
2	532 06 51-39	Stem Valve
3	532 10 62-22	Tire F Ts 15 x 6 0 - 6 Service
4	532 05 99-04	Tube Inner Front #35060
5	532 13 83-36	Rim Asm 6" Front Silver Service
6	532 12 49-57	Fitting Grease
7	532 12 49-59	Bearing Flange
8	532 13 83-37	Rim Asm 8" Rear Silver Service
9	532 12 20-82	Tire R Ts 10 x 8-8 Service
10	532 12 49-26	Tube Rear 9 5 x 8 Service
11	532 17 50-39	Cap Axle Blk 1 50 x 1 00
--	532 14 43-34	Sealant, Tire (10 oz. tube)

NOTE: All component dimensions given in U.S. inches
1 inch = 25.4 mm

TRACTOR - - MODEL NO. CTH180TWIN (96061018601), PRODUCT NO. 960 61 01-86
ELECTRICAL

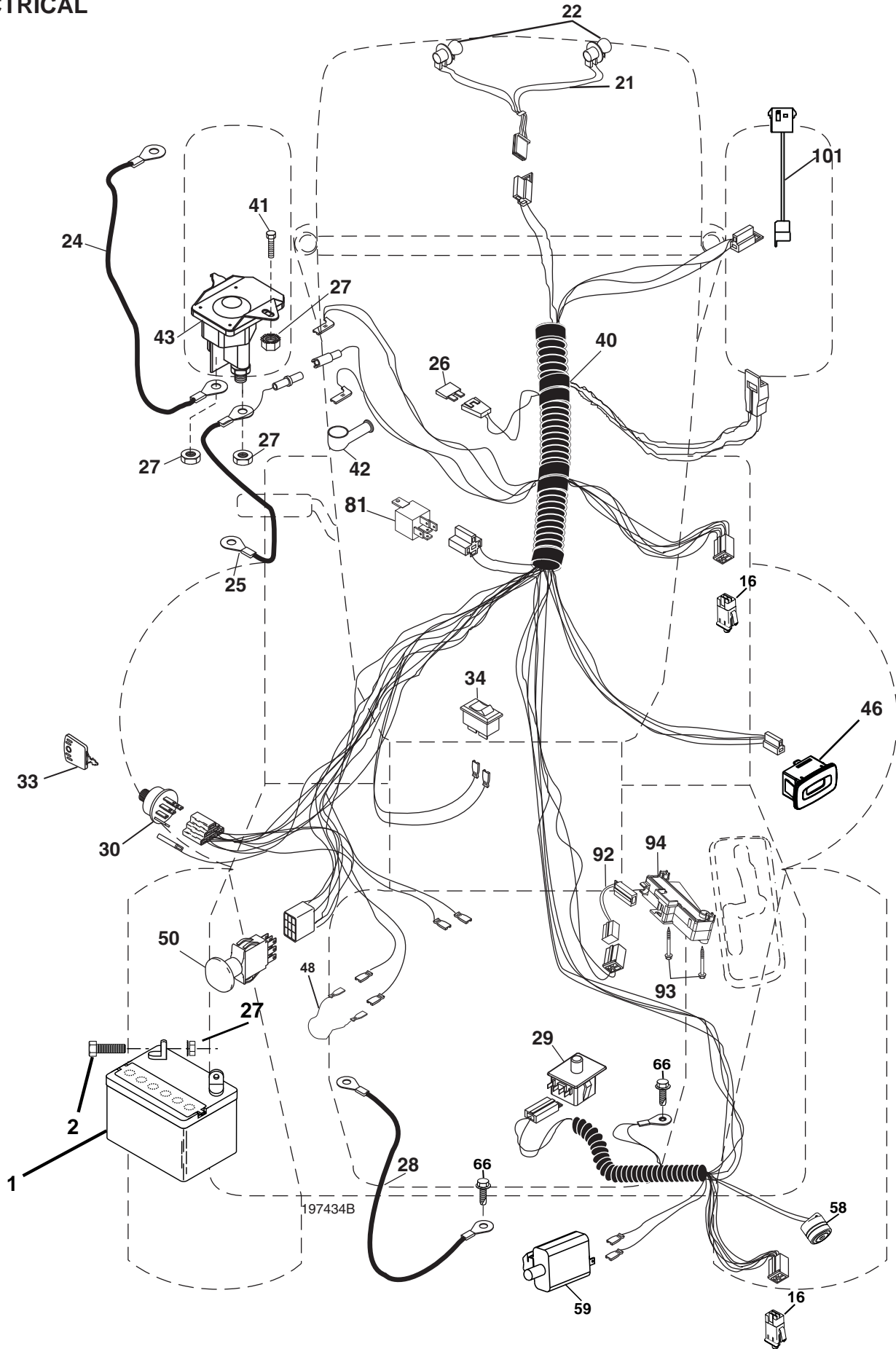

**TRACTOR - - MODEL NO. CTH180TWIN (96061018601), PRODUCT NO. 960 61 01-86
ELECTRICAL**

KEY NO.	PART NO.	DESCRIPTION
1	532 14 49-27	Battery
2	874 76 04-12	Bolt Hex Hd 1/4-20 unc x 3/4
16	532 17 61-38	Switch Interlock
21	532 18 37-59	Harness Asm Light W/4152J
22	532 00 41-52	Bulb Light #1156
24	532 12 47-80	Cable Starter 6 Ga. 11" Red
25	532 16 59-87	Cable Battery CRD 56" Red
26	532 17 51-58	Fuse
27	873 51 04-00	Nut Keps Hex 1/4-20 unc
28	532 12 77-25	Cable Ground 6 Ga. 18" Black
29	532 19 27-49	Switch Seat
30	532 19 33-50	Switch Ignition
33	532 14 04-01	Key Ignition
34	532 11 07-12	Switch Light/Reset B/B/Red
40	532 19 74-34	Harness Ign
41	871 11 04-08	Bolt Flk Fin Hex 1/4-20 unc x 1/2
42	532 13 15-63	Cover Terminal Red
43	532 19 25-07	Solenoid
46	532 40 17-63	Gauge SRVMNDR Hourmeter
48	532 14 08-44	Adapter Ammeter Rectangular
50	532 17 46-51	Switch PTO
58	532 16 94-19	Buzzer CRD
59	532 18 03-79	Switch FBI CRD
66	817 49 06-08	Screw Thdrol 3/8-16 x 1/2 Ty-Tt
81	532 10 97-48	Relay Asm
92	532 19 66-15	Harness Pigtail Console ROS
93	532 19 25-40	Screw Plastite 10-14 x 2.0
94	532 19 18-34	Module Reverse ROS
101	532 19 83-17	Pigtail Matlink New Harness

NOTE: All component dimensions given in U.S. inches.
1 inch = 25.4 mm.

**TRACTOR - - MODEL NO. CTH180TWIN (96061018601), PRODUCT NO. 960 61 01-86
CHASSIS AND ENCLOSURES**

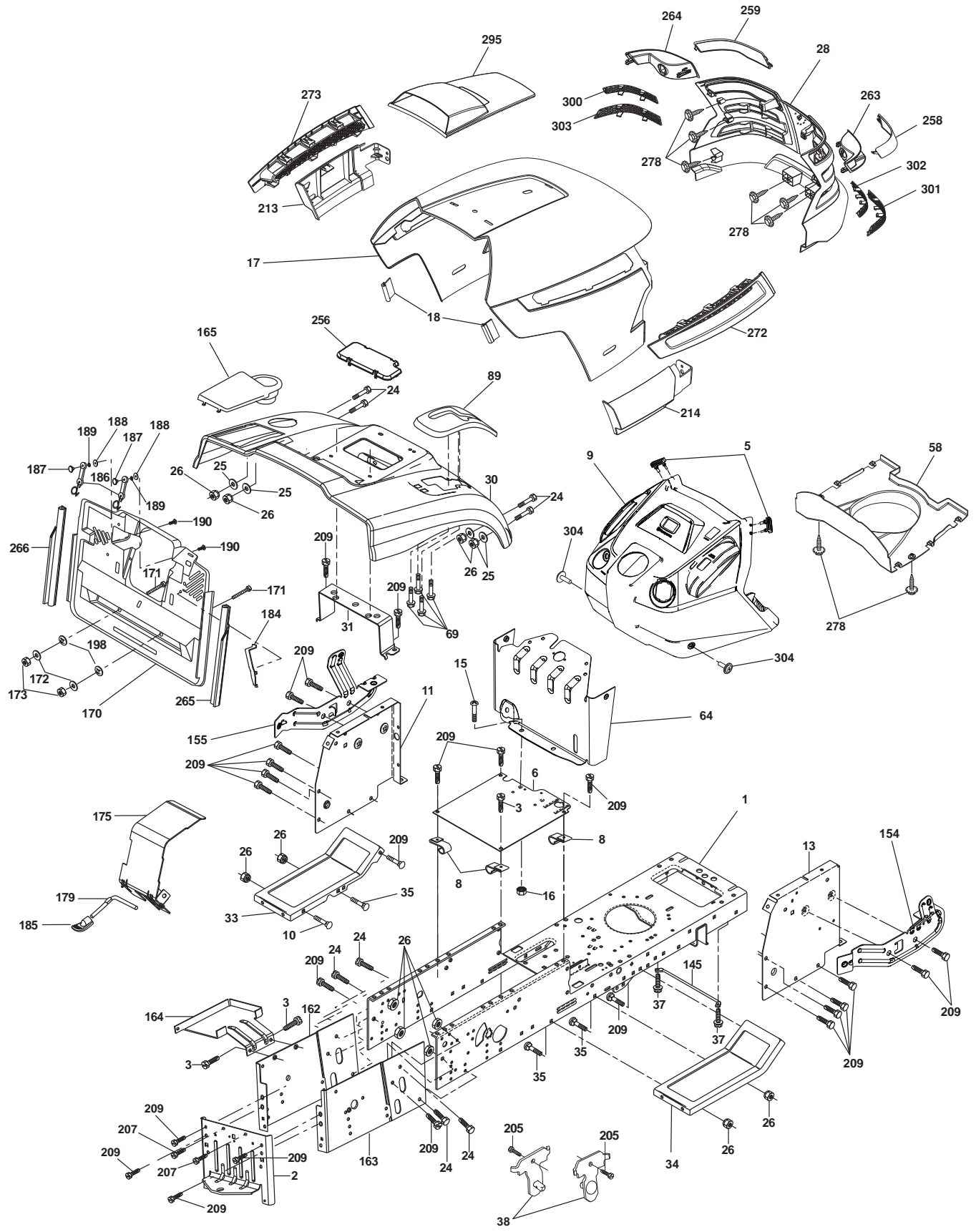

**TRACTOR - - MODEL NO. CTH180TWIN (96061018601), PRODUCT NO. 960 61 01-86
CHASSIS AND ENCLOSURES**

KEY NO.	PART NO.	DESCRIPTION	KEY NO.	PART NO.	DESCRIPTION
1	532 17 46-20	Chassis	172	819 13 20-16	Washer 13/32 x 1-1/4 x 16 Ga.
2	532 18 03-84	Drawbar	173	873 51 06-00	Nut, Keps Hex 3/8-16 unc
3	817 06 06-12	Screw 3/8-16 x 3/4	175	532 18 82-03	Guard Trap
5	532 40 75-90	Bumper Dash	179	532 18 82-02	Rod Pivot FBI CRD
6	532 18 44-19	Saddle	184	532 17 46-62	Bracket Actuator Bagger CRD
8	532 12 64-71	Clip Insulator 13/32 Mtg. Hole	185	532 18 11-01	Knob Rod Brake Parking
9	532 40 89-11	Dash Upper	186	532 16 07-93	Latch Asm Mulch/Bagger
10	872 14 06-08	Bolt, Carriage 3/8-16 x 3/4	187	532 12 50-04	Nut Weld
11	532 16 72-03	Panel, Dash, L.H.	188	819 06 12-16	Washer #10
13	532 17 82-98	Panel, Asm. Dash R.H.	189	810 07 10-00	Washer Lock #10
15	874 18 05-12	Screw, Machine, THD 5/16-18 unc x 3/4	190	871 08 10-10	Screw Pan Hd Phillip 10-24 x 5/8
16	873 51 05-00	Nut Keps 5/16-18 unc	198	532 16 89-37	Nut, Push
17	532 41 10-46	Hood	205	817 49 06-08	Screw Thdrol 3/8-16 x 1/2
18	532 40 47-42	Bumper Hood	207	817 67 05-08	Screw Thdrol 5/16-18 x 1/2
24	874 78 06-16	Bolt	209	817 00 06-12	Screw Hex Wsh Thdrol 3/8-16
25	819 13 13-12	Washer 13/32 x 13/16 x 12 Ga.	213	532 40 17-11	Skirt Side LH
26	873 80 06-00	Nut	214	532 40 17-09	Skirt Side RH
28	532 40 86-07	Grille /Lens Asm	256	532 18 13-61	Cover Fender Rack
30	532 19 73-76	Fender	258	532 19 89-06	Lens RH
31	532 16 51-56	Bracket, Fender Support	259	532 19 89-07	Lens LH
33	532 18 10-57	Footrest, LH	263	532 19 71-98	Bezel RH
34	532 18 10-58	Footrest, RH	264	532 19 71-99	Bezel LH
35	872 11 06-06	Bolt	265	532 18 57-04	Seal RH Side Bagger
37	817 49 05-08	Screw Thdrol 5/16-18 x 1/2 TYT	266	532 18 57-03	Seal LH Side Bagger
38	532 18 17-48	Bracket Asm Pivot Mower Rear	272	532 40 30-48	Vent Hood RH
58	532 19 85-13	Duct Air	273	532 40 30-76	Vent Hood LH
64	532 19 93-95	Dash Lower	278	532 19 16-11	Screw 10 x 3/4 Single Lead-Hex
69	532 14 24-32	Screw Hx Wsh Hi-Lo 1/4-1/2	295	532 40 05-39	Vent Top Hood
89	532 19 73-77	Console CRD Auto Grey	300	532 19 91-31	Insert Hex Top LH
145	532 40 91-67	Rod Pivot Chassis/Hood	301	532 19 91-30	Insert Hex Top RH
154	532 40 86-90	Bracket Mounting Dash RH	302	532 19 91-32	Insert Hex Bottom RH
155	532 40 86-91	Bracket Mounting Dash LH	303	532 19 91-33	Insert Hex Bottom LH
162	532 18 03-82	Bracket Exten Chassis LH CRD	304	817 06 04-10	Hex Tapping Screw
163	532 18 03-83	Bracket Exten Chassis RH CRD			
164	532 16 56-05	Support Battery CRD			
165	532 18 11-00	Cover Battery			
170	532 19 94-88	Backplate CRD			
171	872 14 06-20	Bolt Rdhd Sqnc 3/8-16 x 2-1/2 Gr. 5			

NOTE: All component dimensions given in U.S. inches.
1 inch = 25.4 mm.

**TRACTOR - - MODEL NO. CTH180TWIN (96061018601), PRODUCT NO. 960 61 01-86
DRIVE**

KEY NO.	PART NO.	DESCRIPTION	KEY NO.	PART NO.	DESCRIPTION
1	-----	Transaxle Hydro Gear 321-0510 (Order parts from transaxle manufacturer)	82	532 16 57-11	Spring, Torsion
8	532 19 27-06	Rod, Shift Fender Adjust Lt	83	819 17 12-16	Washer 17/32 x 3/4 x 16 Ga.
9	532 18 02-20	Clutch Electric	84	532 17 00-07	Link, Transaxle
10	876 02 04-16	Pin, Cotter 1/8 x 1	95	532 17 00-15	Control Asm Bypass Hydro
14	810 04 04-00	Washer, Lock Hvy Helical	96	532 12 47-88	Spring, Retainer 1"
15	874 49 05-44	Bolt Hex FGHD 5/16-18 x Gr 5	112	819 09 12-10	Washer 9/32 x 3/4 x 10 Ga.
16	873 80 05-00	Nut, Lock Hex w/Ins 5/16-18 unc	120	873 90 06-00	Nut Lock Fig. 3/8-16 unc
17	532 12 61-97	Washer 1-1/2 OD x 15/32 ID x .250	150	532 16 58-50	Bushing, Bellcrank Grnd Dr
19	873 80 06-00	Nut Lock 3/8-16 unc	151	819 13 32-10	Washer 13/32 x 2 x 10 Ga.
20	532 17 39-37	Bolt, Hex 7/16-20 x 4	156	532 16 60-02	Washer Srrted 5/16 ID x 1.125
21	532 12 12-74	Knob Duckhead 1/4-13 unc Blk	158	532 16 55-89	Bracket Shift Mount
22	532 17 56-07	Rod, Brake	159	532 18 39-00	Hub Tapered Flange Shift Lt
24	873 35 06-00	Nut	161	872 14 04-06	Bolt Rdhd Sqnk 1/4-20 x 3/4 Gr 5
25	532 19 20-36	Spring, Rod, Brake	162	873 68 04-00	Nut Crownlock 1/4-20 unc
27	876 02 04-12	Pin, Cotter 1/8 x 3/4	163	874 78 04-16	Bolt Hex Fin 1/4-20 unc x 1 Gr 5
28	532 17 57-65	Rod, Parking Brake	165	532 16 56-23	Bracket Pivot Lever
29	532 12 42-36	Cap, Parking Brake	166	817 49 05-10	Screw 5/16-18 x 5/8
30	532 16 95-92	Bracket, Mfg. Transaxle	167	532 16 55-88	Bracket Support Shift CRD
34	532 17 55-78	Shaft, Asm Pedal Foot CRD	168	532 16 54-92	Bolt Shoulder 5/16-18 x .561
35	532 12 01-83	Bearing, Nylon	169	532 16 55-80	Plate Fastening Lt
36	819 21 16-16	Washer 21/32 x 1 x 16 Ga.	171	817 49 06-08	Screw Thdrol 3/8-16 x 1/2 Ty-Tt
37	532 12 49-63	Pin, Roll 3/16 x 1"	172	532 17 02-71	Shaft Asm Shifter Frt CRD
38	532 16 59-36	Pulley Flat Composite 3.06"	177	532 16 59-32	Keeper Flat Idler 3.06" CRD
39	874 76 06-44	Bolt Fin Hex 3/8-16 unc x 2-3/4	181	532 18 02-11	Bracket Idler Ground Drive CRD
40	532 12 49-65	Spacer, Split 395 x 59 Bzp	182	532 18 26-82	Keeper Belt 2.5" OD V-Idler CRD
42	819 13 13-12	Washer 13/32 x 13/16 x 12 Ga.	183	532 19 95-32	Pulley V-Idler CRD
43	819 11 10-12	Washer 11/32 x 5/8 x 12 Ga.	185	532 17 00-08	Link Shift
47	532 12 77-83	Pulley, Idler, V Groove Plasic	186	532 16 56-14	Hub Tapered Round CRD
48	532 15 44-07	Bellcrank Clutch Grnd Drv	187	817 58 05-20	Screw Thdrol 5/16-18 x 1.25
49	532 12 32-05	Retainer, Belt Style Spring	197	532 16 96-13	Nyliner Snap-In 5/8
50	872 11 06-12	Bolt Carr SH 3/8-16 x 1-1/2 Gr 5	199	532 16 96-12	Bolt Shoulder 5/16-18 unc
51	873 68 06-00	Nut, Crownlock 3/8-16 unc	200	872 14 05-08	Bolt RDHD SQNK 5/16-18 x 1
52	873 68 05-00	Nut Crownlock 5/16-18	207	532 16 98-45	Washer Nylon Rear
53	532 19 96-52	Link, Clutch 7.66	214	532 17 56-09	Shaft Asm. Brake
55	532 10 57-09	Spring, Return, Clutch	215	532 17 56-52	Rod Brake Hydro
56	817 06 06-20	Screw 3/8-16 x 1-1/4	243	532 19 07-36	Bracket Anti-Rotation
57	532 17 01-40	V-Belt Kev 112" 0650 CRD	252	819 13 16-16	Washer 13/32 x 1 x 16 Ga.
62	532 12 48-72	Cover, Pedal	254	817 00 06-16	Screw 3/8-16 x 1
63	532 18 03-97	Pulley, Engine	255	532 17 56-08	Brace Shaft Brake Mtg.
65	810 04 07-00	Washer	258	532 17 80-62	Clip Retainer
66	532 15 47-78	Keeper, Belt Engine F-Proof	259	532 18 02-12	Bracket Pulley IDL Hydro Grd. Dr.
71	532 16 91-83	Strap, Torque, Lh	260	532 19 76-07	Bracket Idler Chassis
73	532 16 91-82	Strap, Torque, Rh	261	532 13 14-94	Pulley Idler Flat
74	532 13 70-57	Spacer, Split	262	872 11 06-22	Bolt Rdhd 3/8-16 unc x 2-3/4 Gr 5
75	532 12 17-49	Washer 25/32 x 1-1/4 x 16 Ga.	263	817 00 06-12	Screw HXWSH THDROL 3/8-16 x 3/4 Blk
76	812 00 00-01	Ring, E	266	532 18 20-61	Shield Idler Mower CRD
77	532 12 35-83	Key, Square	279	872 11 06-16	Bolt Rdhd Sqnk 3/8-16 unc x 2
78	532 12 17-48	Washer 25/32 x 1-5/8 x 16 Ga.	292	532 40 02-71	Spacer Noram CRD
81	532 17 00-06	Asm, Shaft	295	532 17 91-14	Pulley Idler Composite

NOTE: All component dimensions given in U.S. inches
1 inch = 25.4 mm

TRACTOR - - MODEL NO. CTH180TWIN (96061018601), PRODUCT NO. 960 61 01-86
MOWER

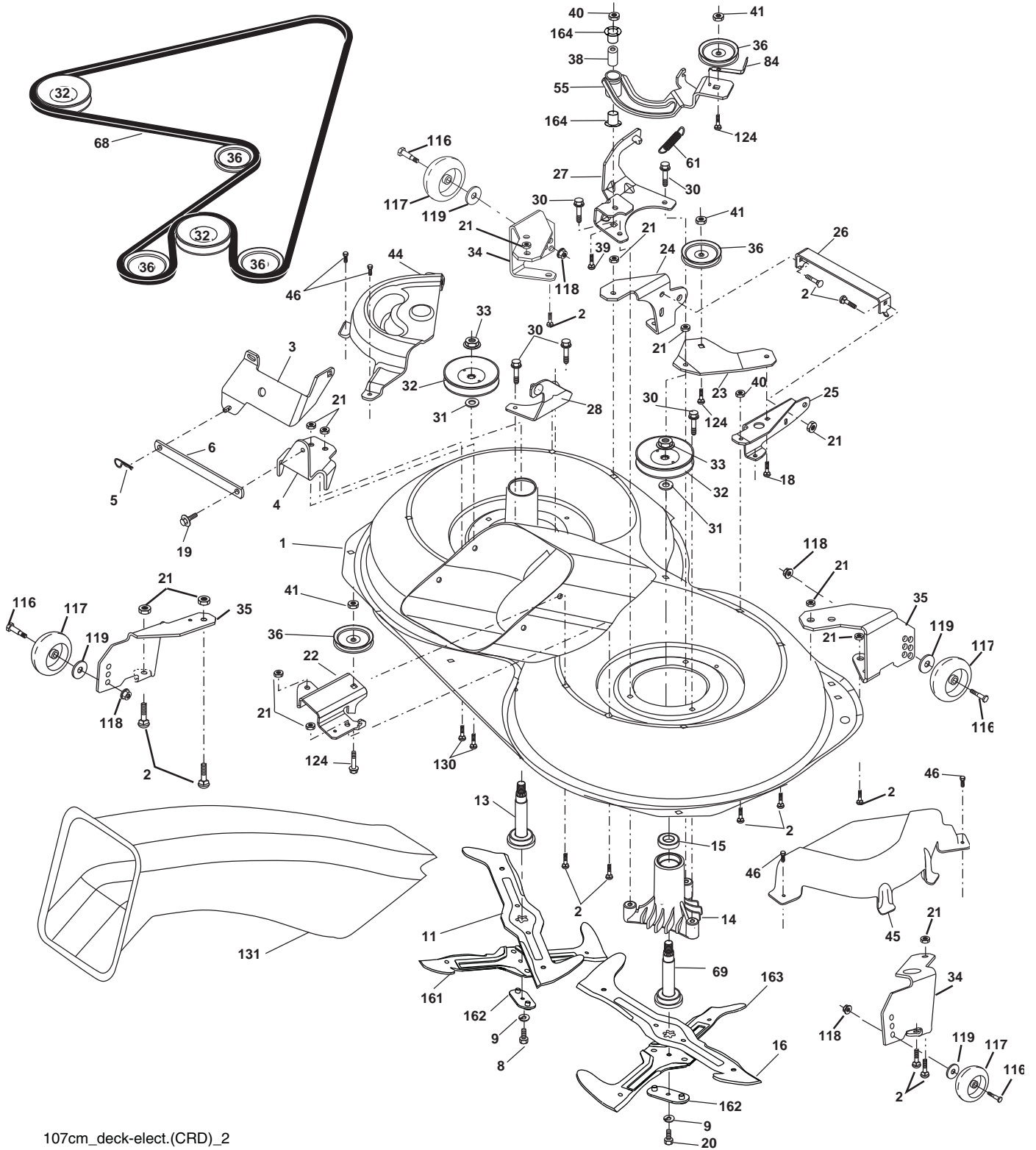

107cm_deck-elect.(CRD)_2

**TRACTOR - - MODEL NO. CTH180TWIN (96061018601), PRODUCT NO. 960 61 01-86
MOWER**

KEY NO.	PART NO.	DESCRIPTION	KEY NO.	PART NO.	DESCRIPTION
1	532 16 91-60	Housing Asm. Mower	36	532 14 67-63	Pulley Idler V-Groove Dim 4.25
2	872 14 05-06	Bolt Rdhd Sqnk 5/16-18 unc x 3/4	38	532 16 98-51	Spacer Hub Arm Idler
3	532 16 55-69	Bracket Asm. S-Bar Chass	39	872 11 06-22	Bolt RhHd 3/8-16 unc x 2-3/4 Gr. 5
4	532 16 91-67	Bracket Bar Sway Deck	40	873 68 06-00	Nut Crownlock 3/8-16 unc
5	532 12 46-70	Retainer Spring	41	873 90 06-00	Nut Flangelock 3/8-16 unc
6	532 16 55-57	Bar Sway	44	532 17 55-38	Cover Mandrel Lh
8	532 18 17-12	Bolt 3/8-24 x 1.25 Gr. 8 Patched	45	532 17 55-39	Cover Mandrel Rh
9	810 03 06-00	Washer Lock Hvy 3/8 Unplated	46	532 13 77-29	Screw Thd Roll 1/4-20 x 5/8
11	532 18 05-83	Blade 3-1 Lh	55	532 16 98-49	Arm Idler
13	532 16 54-82	Shaft Asm. W/Lower Bearing	61	532 17 51-59	Spring Tension Belt
14	532 12 87-74	Housing Mandrel Vented (Machd)	68	532 40 20-09	Hex-Belt Mower
15	532 11 04-85	Bearing Ball Mandrel	69	532 13 76-45	Shaft Asm W/Lwr Brg Rh Thd CRD
16	532 18 05-84	Blade 3-1 Rh	84	532 15 60-85	Keeper Belt Idler
18	872 11 06-06	Bolt RDHD SHT SQNK 3/8-16 x 3/4	116	532 19 34-06	Bolt Shoulder
19	532 13 28-27	Bolt Shoulder 5/16-18 Thd Form	117	532 17 48-73	Wheel Gauge
20	532 18 17-13	Bolt 3/8-24 x 1.25 Gr. 8 Ptch Lhthd	118	873 90 06-00	Nut Centerlock 3/8-16 unc
21	873 68 05-00	Nut Crown Lock 5/16-18	119	819 13 20-12	Washer 3/8 x 7/8 x 14 Ga.
22	532 16 91-65	Bracket Idler Sprt RR	124	872 11 06-12	Bolt Carr Sh 3/8-16 x 1-1/2 Gr. 5
23	532 16 91-66	Bracket Idler Sprt RF	130	872 11 05-06	Bolt Rdhdsqnk 5/16-18 unc x 3/4
24	532 16 91-70	Bracket Suspension LF	131	532 16 56-61	Chute Bagger CRD 92cm
25	532 40 01-05	Bracket Suspension RF	161	532 18 04-24	Blade Cross LH 107
26	532 40 01-10	Brace Support Susp Frt CRD	162	532 18 08-78	Adapter Weldment Blade 107
27	532 16 91-72	Bracket Asm. Susp RR	163	532 18 04-25	Blade Cross RH 107
28	532 16 91-68	Bracket Asm. Susp LR	164	532 12 49-37	Bearing
30	532 17 39-84	Screw Thd Rolling Dod. PT Hex	--	532 18 18-57	Mandrel Asm Service
31	532 18 76-90	Washer Spacer Mandrel	--	532 18 18-58	Mandrel Asm CRD Lh Threads VC
32	532 17 57-07	Mandrel Pulleys	--	532 18 17-70	Replacement Mower Complete (Std. Deck - Order separately gauge wheel components key nos. 116-119)
33	532 40 02-34	Nut Flg Top Lock			
34	532 40 01-03	Bracket Gauge Wheel Lf			
35	532 40 01-04	Bracket Gauge Wheel Rf			

NOTE: All component dimensions given in U.S. inches
1 inch = 25.4 mm

**TRACTOR - - MODEL NO. CTH180TWIN (96061018601), PRODUCT NO. 960 61 01-86
STEERING ASSEMBLY**

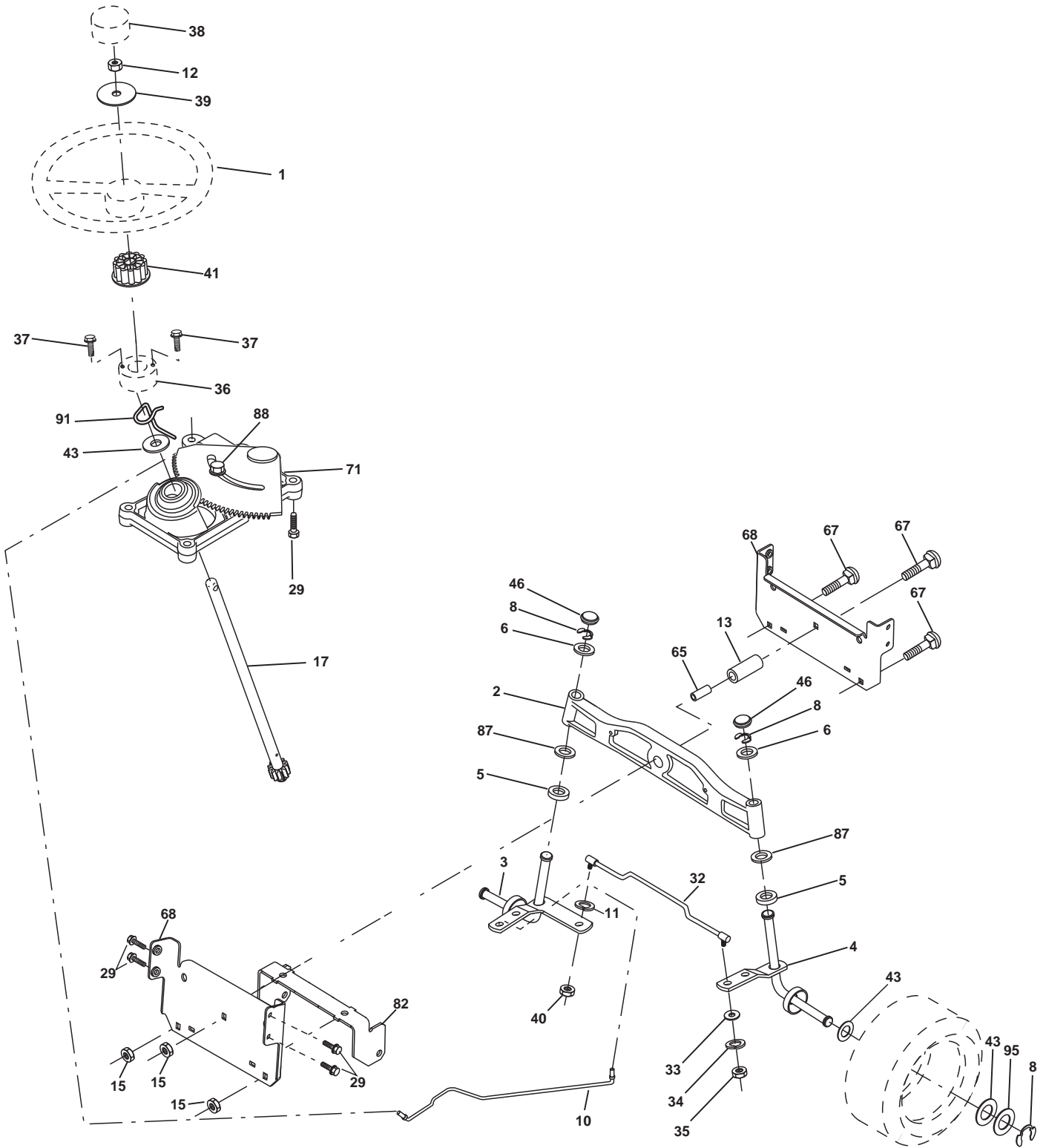

steering_pl.it_53

**TRACTOR - - MODEL NO. CTH180TWIN (96061018601), PRODUCT NO. 960 61 01-86
STEERING ASSEMBLY**

KEY NO.	PART NO.	DESCRIPTION
1	532 19 36-51	Steering Wheel
2	532 18 47-06	Front Axle Assembly
3	532 16 98-40	Spindle Assembly, L.H.
4	532 16 98-39	Spindle Assembly, R.H.
5	532 12 49-31	Bearing, Race, Thrust, Hardened
6	532 12 17-48	Washer 25/32 x 1-5/8 x 16 Ga.
8	812 00 00-29	Ring, Klip
10	532 17 51-21	Draglink
11	810 04 06-00	Washer, Lock
12	873 94 08-00	Nut Hex Gr 2 Toplock 1/2-20 unf
13	532 13 65-18	Spacer Axle
15	532 14 52-12	Nut Hex Flange Lock
17	532 17 78-83	Shaft Assembly, Steering
29	817 00 06-12	Screw 3/8-16 x 3/4
32	532 17 18-88	Rod, Tie
33	819 11 12-16	Washer 11/32 x 3/4 x 16 Ga.
34	810 04 05-00	Washer Lock Hvy Hlcl Spr 5/16
35	873 54 05-00	Crownlock Nut 5/16-24 unf
36	532 15 51-05	Bushing, Steering
37	532 15 29-27	Screw TT #10-32 x 5 x 3/8 Flange
38	532 19 36-52	Cap Wheel Steer
39	819 18 38-12	Washer 11/32 ID x 2-3/8 OD x 12 Ga.
40	873 54 06-00	Nut Crownlock 3/8-24
41	532 18 67-37	Adaptor, Steering Wheel
43	532 12 17-49	Washer 25/32 x 1-1/4 x 16 Ga.
46	532 12 12-32	Cap, Spindle
65	532 16 03-67	Spacer Axle
67	872 11 06-18	Bolt Rdhd Sq 3/8-16 x 2-1/4
68	532 16 98-27	Brace Axle
71	532 17 51-46	Steering Asm.
82	532 19 99-78	Bracket Susp. Chassis Front
87	532 17 39-66	Washer Flat .781 x 1-1/2 x .14
88	532 17 51-18	Bolt Shoulder 7/16-20 unc
91	532 17 55-53	Clip Steering
95	532 18 89-67	Washer Hardened

NOTE: All component dimensions given in U.S. inches.
1 inch = 25.4 mm.

**TRACTOR - - MODEL NO. CTH180TWIN (96061018601), PRODUCT NO. 960 61 01-86
ENGINE**

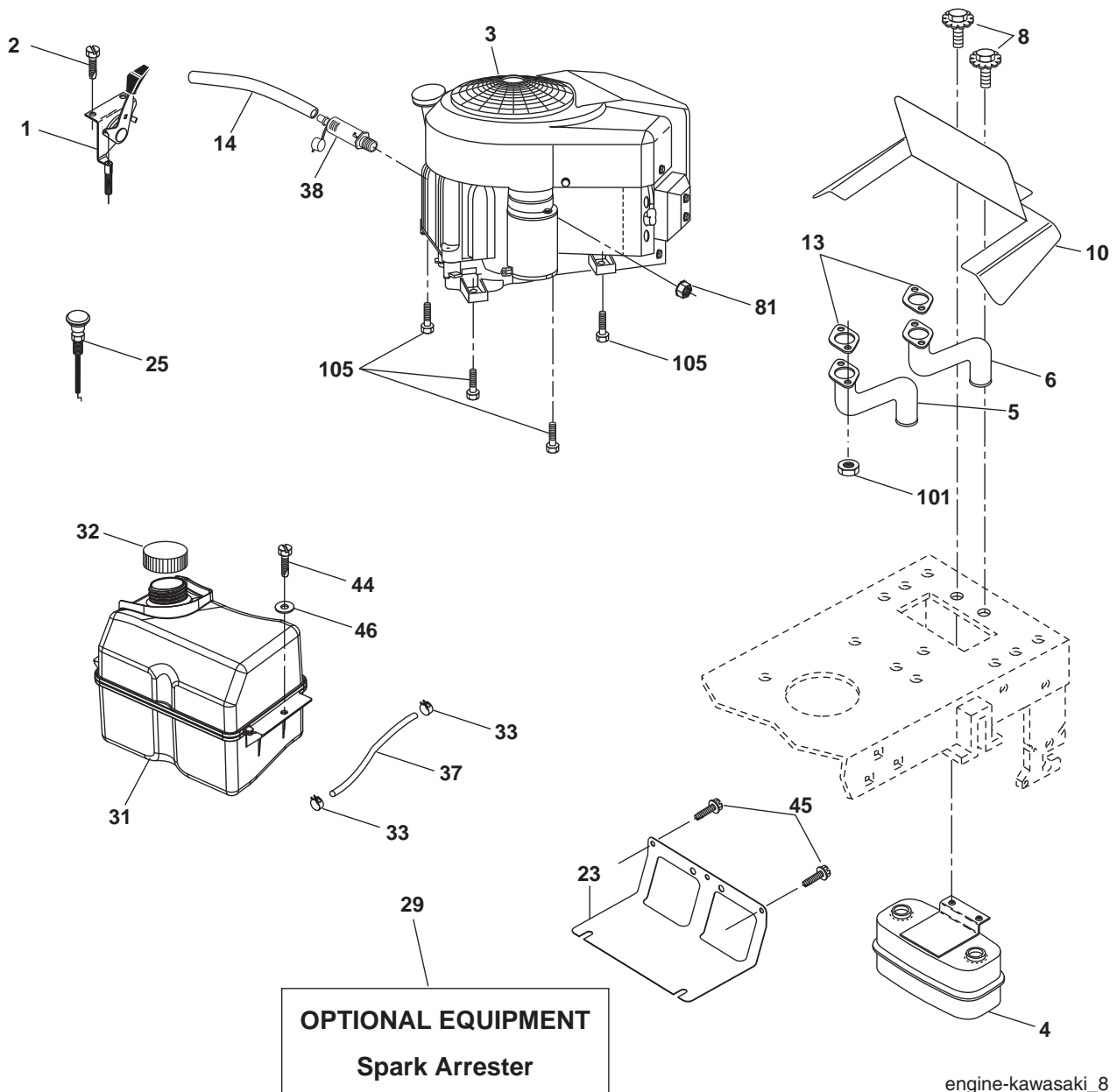

KEY NO.	PART NO.	DESCRIPTION
1	532 17 83-85	Control Throttle
2	532 19 16-11	Screw 10 x 3/4 Single Hex Lead
3	-----	Engine KAWA FH531V (Order parts from engine manufacturer)
4	532 14 97-23	Muffler Twin Lo-Tone
5	532 17 60-67	Tube, Manifold Lh
6	532 17 60-68	Tube, Manifold Rh
8	532 17 18-77	Bolt 5/16-18 unc x 3/4 w/Sems
10	532 14 66-29	Shield Browning Intek
13	-----	Gasket Muffler (Order parts from engine manufacturer)
14	532 14 84-56	Tube Drain Oil Easy
23	532 16 98-37	Shield Brn/Dbr Guard
25	532 18 95-41	Choke Control

KEY NO.	PART NO.	DESCRIPTION
29	532 13 71-80	Kit Spark Arrestor (Flat Scrn)
31	532 40 74-89	Tank Fuel
32	532 19 77-25	Cap Asm Fuel
33	532 12 34-87	Clamp Hose Blk
37	532 13 70-40	Line Fuel
38	-----	Plug Drain Oil Easy (Order parts from engine manufacturer)
44	817 67 04-12	Screw Hexwsh Thdrol 1/4-20 x 3/4
45	817 00 06-12	Screw Hexwsh Thdrol 3/8-16 x 3/4
46	819 09 14-16	Washer 9/32 x 7/8 x 16 Ga.
81	873 51 04-00	Nut Keps Hex 1/4-20 unc
101	532 18 43-62	Nut Hex Flange Toplock M8-1.25
105	817 12 06-16	Screw 3/8-16 x 1 SMGML TAP/R

NOTE: All component dimensions given in U.S. inches
1 inch = 25.4 mm

TRACTOR - - MODEL NO. CTH180TWIN (96061018601), PRODUCT NO. 960 61 01-86 SEAT ASSEMBLY

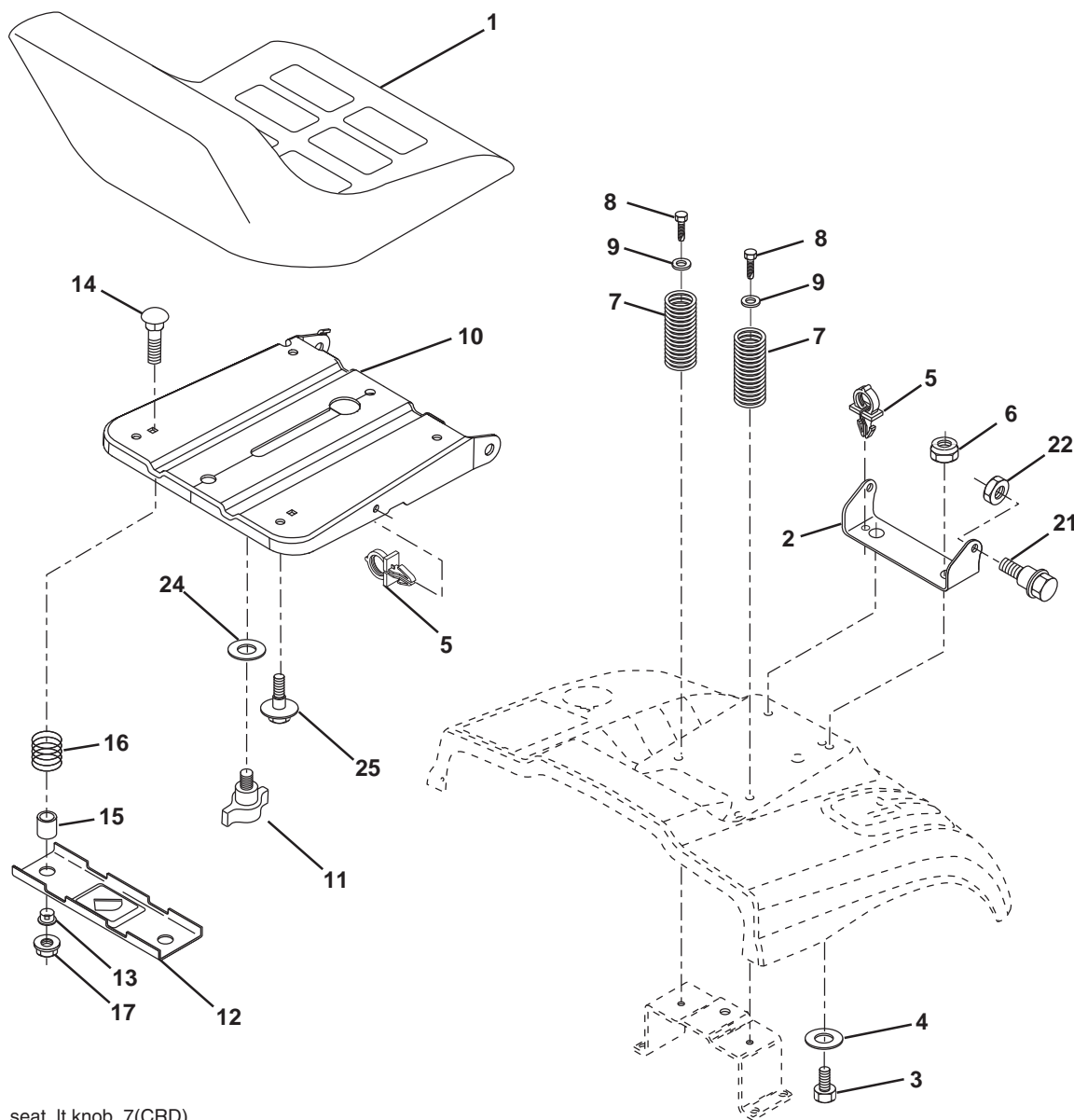

seat_lt.knob_7(CRD)

KEY NO.	PART NO.	DESCRIPTION
1	532 18 87-15	Seat
2	532 14 05-51	Bracket Pnt Pivot Seat (blk)
3	871 11 06-16	Bolt Fin Hex 3/8-16 x 1 Blk
4	819 13 16-10	Washer Flat 13/32 x 1 x 10 Ga.
5	532 14 50-06	Clip Push In Hinged
6	873 80 06-00	Nut Lock Hex w/Insert 3/8-16
7	532 12 41-81	Spring Seat Cprsn 2.250 Blk Zi
8	817 00 06-16	Screw 3/8-16 x 1.5
9	819 13 16-14	Washer 13/32 x 1 x 14 Ga.
10	532 19 55-30	Pan Pnt Seat
11	532 16 63-69	Knob Seat Adj. Wingnut

KEY NO.	PART NO.	DESCRIPTION
12	532 17 46-48	Bracket Pnt Mounting Switch
13	532 12 12-48	Bushing Snap Blk Nyl 50 Id
14	872 05 04-12	Bolt Rdhd Sht Nk 1/4-20 x 1-1/2
15	532 12 12-49	Spacer Split
16	532 12 37-40	Spring Cprsn
17	532 12 39-76	Nut Lock 1/4 Lge Flg Gr. 5 Zinc
21	532 17 18-52	Bolt Shoulder 5/16-18 unc-2A
22	873 80 05-00	Nut Hex Lock w/Ins 5/16-18
24	819 17 19-12	Washer 17/32 x 1-3/16 x 12 Ga.
25	532 12 70-18	Bolt Shoulder 5/16-18 x 62

NOTE: All component dimensions given in U.S. inches.
1 inch = 25.4 mm

TRACTOR - - MODEL NO. CTH180TWIN (96061018601), PRODUCT NO. 960 61 01-86
MOWER LIFT

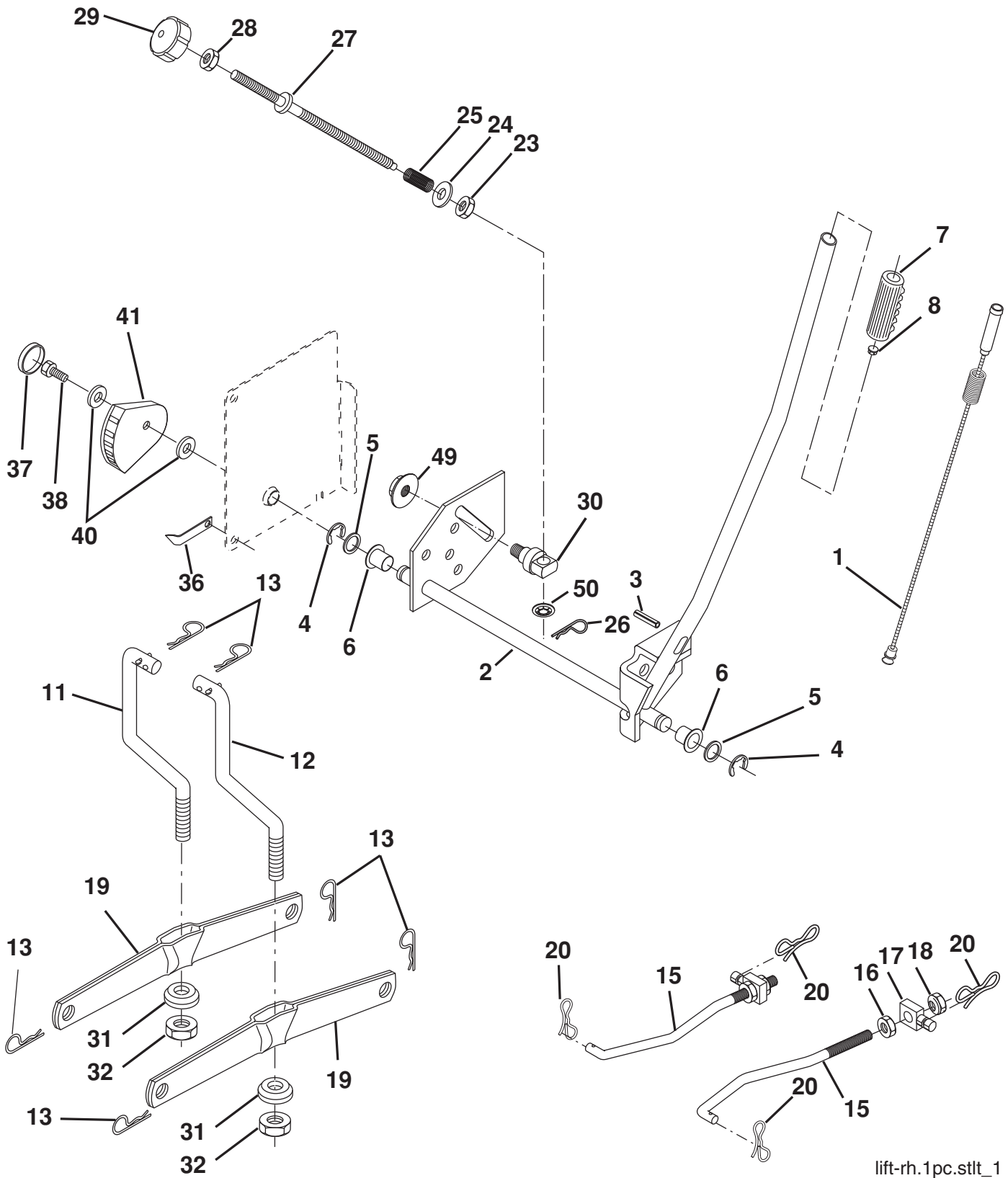

lift-rh.1pc.stlt_1

**TRACTOR - - MODEL NO. CTH180TWIN (96061018601), PRODUCT NO. 960 61 01-86
MOWER LIFT**

KEY NO.	PART NO.	DESCRIPTION
1	532 19 84-17	Washer Asm Inner Spring W/Plunger
2	532 19 80-70	Shaft Asm. Lift RH
3	532 18 88-22	Pin Groove
4	812 00 00-02	E Ring #5133-62
5	819 21 16-21	Washer 21/32 x 1 x 21 Ga.
6	532 12 01-83	Bearing Nylon
7	532 12 56-31	Grip Handle Fluted
8	532 12 23-65	Button Plunger Black
11	532 16 58-29	Link Asm Lift L.H.
12	532 16 58-31	Link Asm Lift R.H.
13	532 12 46-70	Retainer Spring
15	532 17 32-88	Link Front
16	873 35 08-00	Nut Jam Hex 1/2-13 unc
17	532 17 56-89	Trunnion Blk Zinc
18	873 80 08-00	Nut Lock w/Wsh 1/2-13 unc
19	532 13 98-68	Arm Suspension Mower
20	532 19 42-09	Pin Cotter Bowtie Lock
23	532 11 08-07	Nut Special
24	819 13 10-16	Washer 13/32 x 5/8 x 16 Ga.
25	532 16 40-24	Spring
26	532 16 94-84	Retainer Clip
27	532 16 45-43	Rod Adj Lift
28	873 35 06-00	Nut Hex Jam 3/8-16 unc
29	532 13 80-57	Knob Inf 3/8-16 unc Blk w/sym
30	532 15 02-33	Trunnion Infin Height
31	532 16 98-65	Bearing, Pvt. Lift.
32	873 54 06-00	Nut Crownlock 3/8-24
36	532 15 50-97	Pointer Height Indicator
37	532 12 39-35	Plug Hole Blk 1.485/1.515 Dia
38	817 06 05-16	Screw 5/16-18 x 1
40	819 11 24-10	Washer 11/32 x 1-1/2 x 10 Ga.
41	532 12 39-34	Scale Ind Height Blk
49	532 14 52-12	Nut Hex Flange Lock
50	532 11 04-52	Nut Push Phos & Oil

NOTE: All component dimensions given in U.S. inches
1 inch = 25.4 mm

**TRACTOR - - MODEL NO. CTH180TWIN (96061018601), PRODUCT NO. 960 61 01-86
BAGGER**

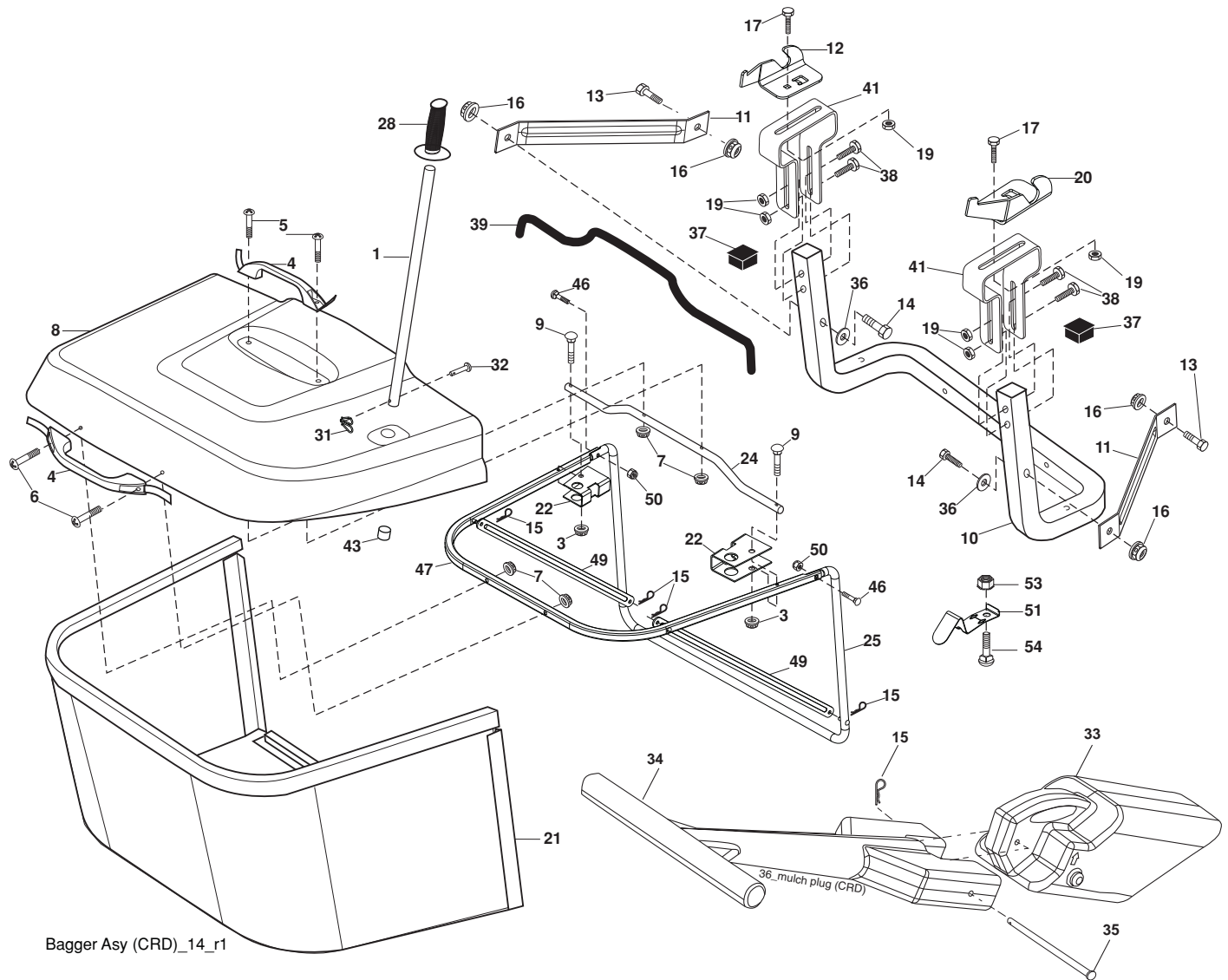

Bagger Asy (CRD)_14_r1

KEY NO.	PART NO.	DESCRIPTION	KEY NO.	PART NO.	DESCRIPTION
1	532 16 52-49	Tube Handle Bagger CRD	28	532 16 57-87	Grip Handle Black
3	532 12 39-76	Nut Lock 1/4 Lge Flg Gr. 5 Zinc	31	532 16 94-84	Retainer Clip
4	532 16 99-16	Handle Bagger w/Lvrs Blk CRD	32	532 12 68-75	Rivet Rd Hd Drilled 3/8 Dia
5	874 98 10-24	Screw Pan Head #10-24 x 1.50 Blk	33	532 16 93-80	Plug Mulcher 107 CRD
6	874 98 10-32	Screw Pan Hd	34	532 16 55-70	Handle Mulcher
7	873 40 10-00	Nut Wiz Lock Hex Serr/Hd 10-24	35	532 16 55-72	Pin Mulcher
8	532 16 99-63	Cover Bagger	36	819 13 20-12	Washer 13/32 x 1-1/4 x 12 Ga.
9	872 14 04-18	Bolt Carriage 1/4-20 x 2.25d x Gr.5	37	532 17 54-01	Plug Support Bagger CRD
10	532 18 12-82	Tube Support Bagger CRD	38	872 01 05-20	Bolt 5/16-18 x 2-1/2
11	532 16 57-19	Bracket Support Upper Bag CRD	39	532 18 09-85	Seal Trim
12	532 18 88-48	Bracket Pivot LH	41	532 16 96-83	Bracket Pnt Adj Pvt Bagger CRD
13	874 76 06-12	Bolt Fin Hex 3/8-16 UNC x 3/4	43	532 17 40-83	Plug Tubing End
14	874 52 06-36	Bolt Fin Hex 3/8-16 x 2-1/4 Gr. 5	46	872 11 05-10	Bolt Carr. 5/16-18 x 1-1/4 Gr. 5
15	532 12 46-70	Retainer Spring	47	532 19 37-04	Tube Upper Bagger
16	873 90 06-00	Nut Lock Flg 3/8-16 unc	49	532 19 33-05	Bar Spreader Bagger
17	872 14 05-06	Bolt Rdhd Sht Sqnk 5/16 -18 unc x 3/4	50	873 80 05-00	Nut Lock Hx W/Ins. 5/16-18 unc
19	873 90 05-00	Nut Lock Hex Flange 5/16-18	51	532 19 99-03	Latch Spring Bagger
20	532 18 88-47	Bracket Pivot Rh	52	872 14 04-06	Bolt Rdhd Sqnk 1/4-20 x 3/4 Gr. 5
21	532 40 61-80	Bag Asm CRD	53	873 51 04-00	Nut Keps Hex 1/4-20 unc
22	532 16 57-81	Bracket Side Bagger CRD			
24	532 16 57-83	Tube Pivot Bagger CRD			
25	532 19 37-05	Tube Front Bagger CRD			

NOTE: All component dimensions given in U.S. inches
1 inch = 25.4 mm