

# CT151

**Spare parts**  
**Ersatzteile**  
**Pièces détachées**  
**Reserve onderdelen**  
**Repuestos**  
**Reservdelar**

# ILLUSTRATED PARTS LIST

**MFG. ID NO. 96061018002**

**CUSTOMER CATALOG NO. CT151**

**PRODUCT NO. 960 61 01-80**

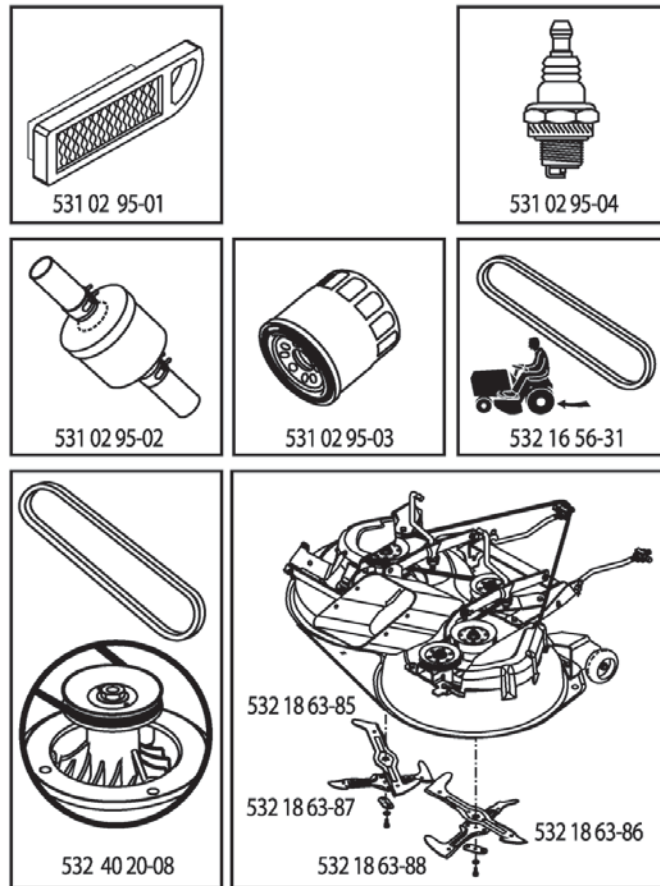

412758

**TRACTOR- -MODEL NO. CT151 (96061018002) PRODUCT NO. 960 61 01-80  
DECALS**

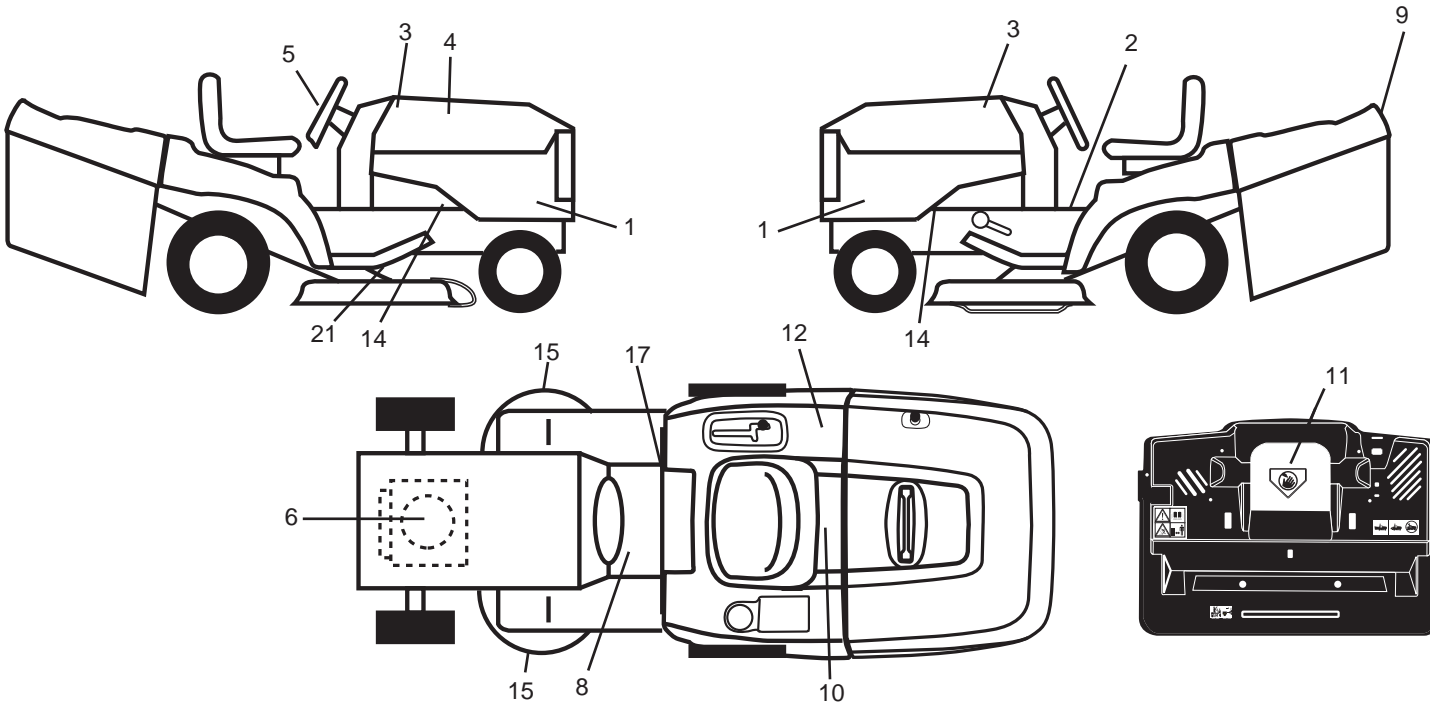

KEY NO.	PART NO.	DESCRIPTION
1	532 41 22-41	Decal, Side Panel
2	532 40 03-89	Decal, Warning Symbols CE
3	532 40 28-32	Decal, Hood
4	532 41 27-58	Decal, Replacement
5	532 40 44-84	Decal, Wheel Logo
6	532 19 68-41	Decal, Warning Engine Symbols
8	532 15 97-37	Decal, Brake/Clutch Symbol
9	532 40 28-32	Decal, Fender
10	532 14 50-05	Decal, Bat Dan/Poi P/L Sym Wpn

KEY NO.	PART NO.	DESCRIPTION
11	532 18 21-66	Decal, Mower Cutfinger Symbol
12	532 18 04-32	Decal, Fender 100 DB/CE
14	532 15 97-36	Decal, Chassis Hot Muffler
15	532 19 68-42	Decal, Warning Cutfinger
17	532 14 08-37	Decal, Saddle Brake Parking
21	532 16 62-86	Decal, Deck Sch 92 CRD
--	532 13 83-11	Decal, Lift Handle
--	532 18 19-16	Pad Footrest LH
--	532 18 19-17	Pad Footrest RH
--	532 41 19-43	Manual Operator's (Euro)

**WHEELS & TIRES**

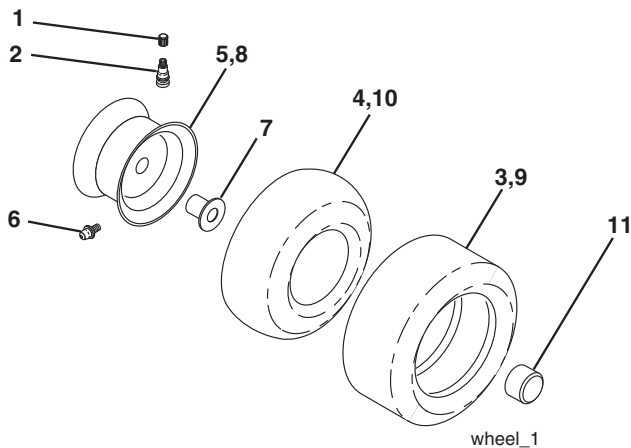

KEY NO.	PART NO.	DESCRIPTION
1	532 05 91-92	Cap Valve Tire
2	532 06 51-39	Stem Valve
3	532 10 62-22	Tire F Ts 15 x 6 0 - 6 Service
4	532 05 99-04	Tube Inner Front #35060
5	532 13 83-36	Rim Asm 6" Front Service
6	532 12 49-57	Fitting Grease
7	532 12 49-59	Bearing Flange
8	532 13 83-37	Rim Asm 8" Rear Service
9	532 10 62-68	Tire R Ts 18 x 9.5-8 Service
10	532 12 49-26	Tube Rear 9 5 x 8 Service
11	532 17 50-39	Cap Axle Blk 1 50 x 1 00
--	532 14 43-34	Sealant, Tire (10 oz. tube)

**NOTE:** All component dimensions given in U.S. inches.  
1 inch = 25.4 mm

# TRACTOR- -MODEL NO. CT151 (96061018002) PRODUCT NO. 960 61 01-80 SCHEMATIC

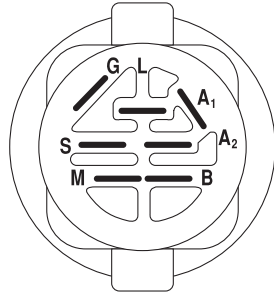
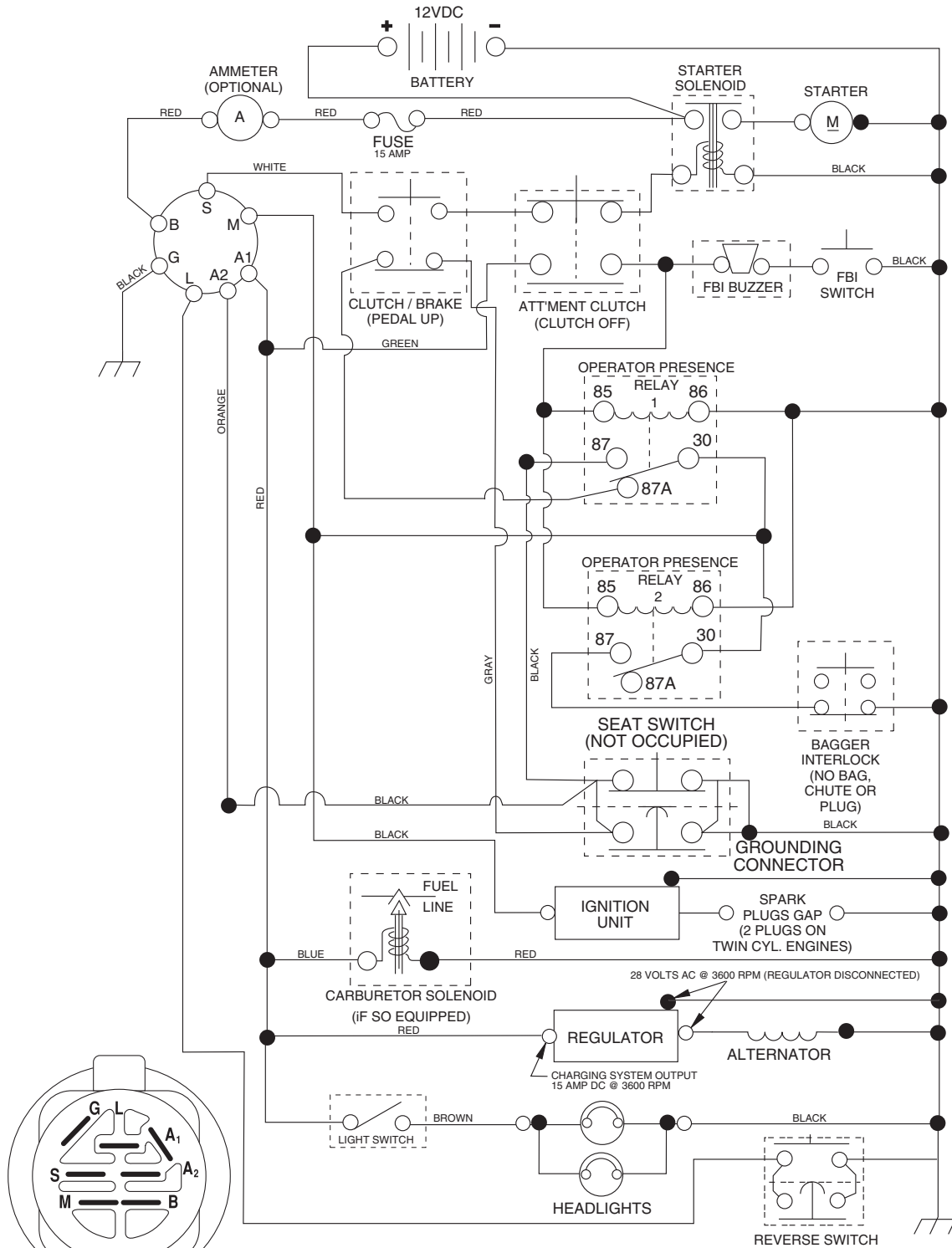

**IGNITION SWITCH**

POSITION	CIRCUIT	"MAKE"
OFF	M+G+A1	
RUN/OVERRIDE	B+A1	
RUN	B+A1	L+A2
START	B + S + A1	

**WIRING INSULATED CLIPS**  
**NOTE: IF WIRING INSULATED CLIPS WERE REMOVED FOR SERVICING OF UNIT, THEY SHOULD BE REPLACED TO PROPERLY SECURE YOUR WIRING.**

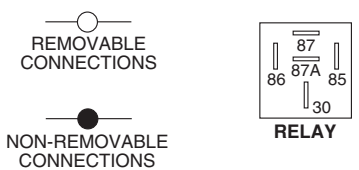

03050

TRACTOR- -MODEL NO. CT151 (96061018002) PRODUCT NO. 960 61 01-80  
ELECTRICAL

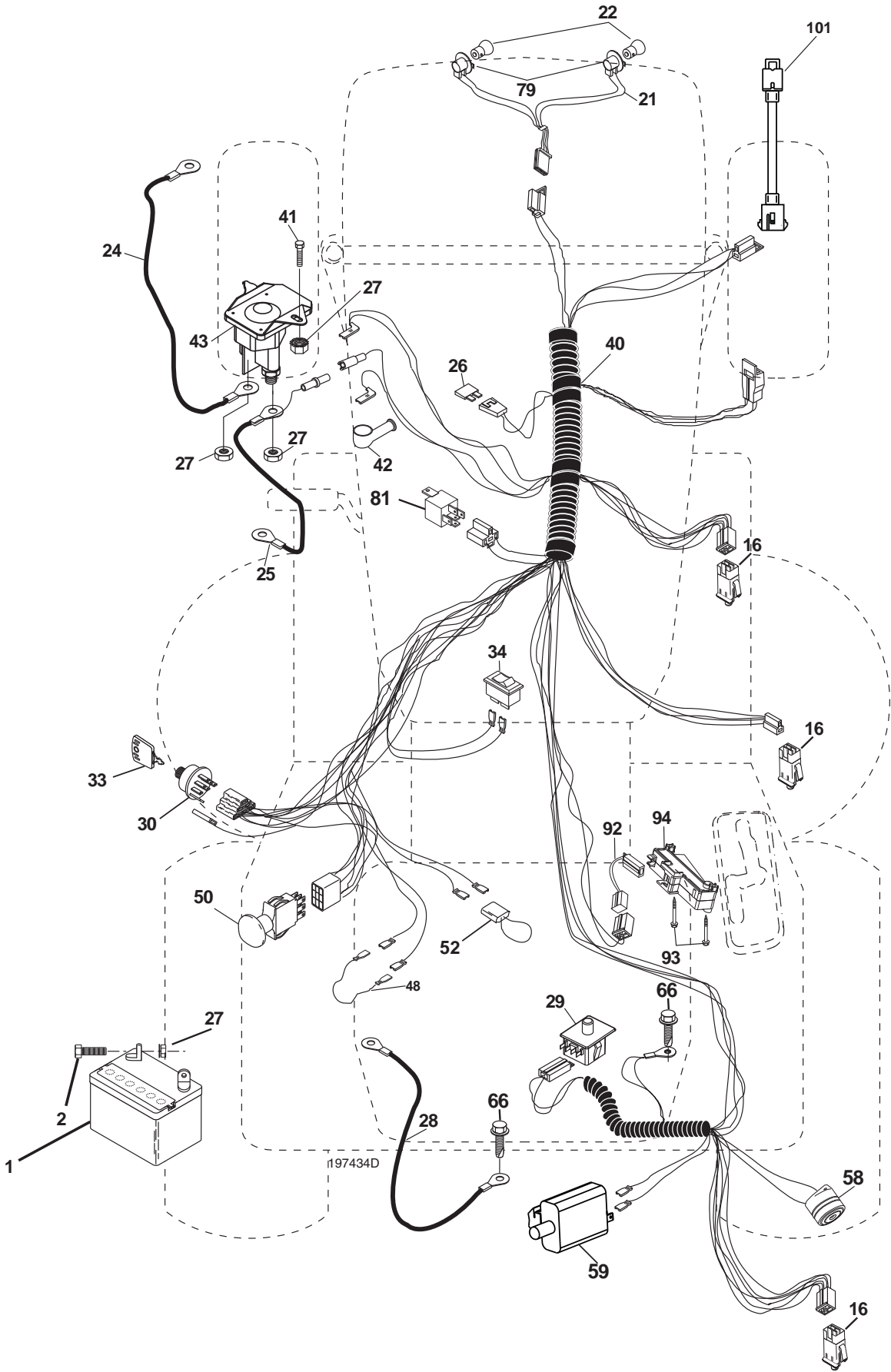

**TRACTOR- -MODEL NO. CT151 (96061018002) PRODUCT NO. 960 61 01-80  
ELECTRICAL**

<b>KEY NO.</b>	<b>PART NO.</b>	<b>DESCRIPTION</b>
1	532 14 49-27	Battery
2	874 76 04-12	Bolt Hex Hd 1/4-20 unc x 3/4
16	532 17 61-38	Switch Interlock
21	532 40 02-52	Harness Asm Light W/4152J
22	532 00 41-52	Bulb Light #1156
24	532 12 47-80	Cable Starter 6 Ga. 11" Red
25	532 16 59-87	Cable Battery Crd 56" Red
26	532 17 51-58	Fuse
27	873 51 04-00	Nut Keps Hex 1/4-20 unc
28	532 12 77-25	Cable Ground 6 Ga. 18" Black
29	532 19 27-49	Switch Seat
30	532 19 33-50	Switch Ignition
33	532 14 04-01	Key Ign Molded
34	532 11 07-12	Switch Light
40	532 19 74-34	Harness Ign
41	871 11 04-08	Bolt Flk Fin Hex 1/4-20 unc x 1/2
42	532 13 15-63	Cover Terminal Red
43	532 19 25-07	Solenoid
48	532 14 08-44	Adapter Ammeter Rectangular
50	532 17 46-51	Switch PTO
52	532 14 19-40	Protection Wire Loop
58	532 16 94-19	Buzzer Crd
59	532 18 03-79	Switch FBI CRD
66	817 49 06-08	Screw Thdrol 3/8-16 x 1/2 Ty-Tt
79	532 17 52-42	Socket Asm
81	532 10 97-48	Relay Asm
92	532 19 66-15	Harness Pigtail
93	532 19 25-40	Screw Plastite 10-14 x 2.0
94	532 19 18-34	Module Reverse
101	532 19 83-17	Pigtail Matnlk

**NOTE:** All component dimensions given in U.S. inches.  
1 inch = 25.4 mm.

# TRACTOR- -MODEL NO. CT151 (96061018002) PRODUCT NO. 960 61 01-80

## CHASSIS AND ENCLOSURES

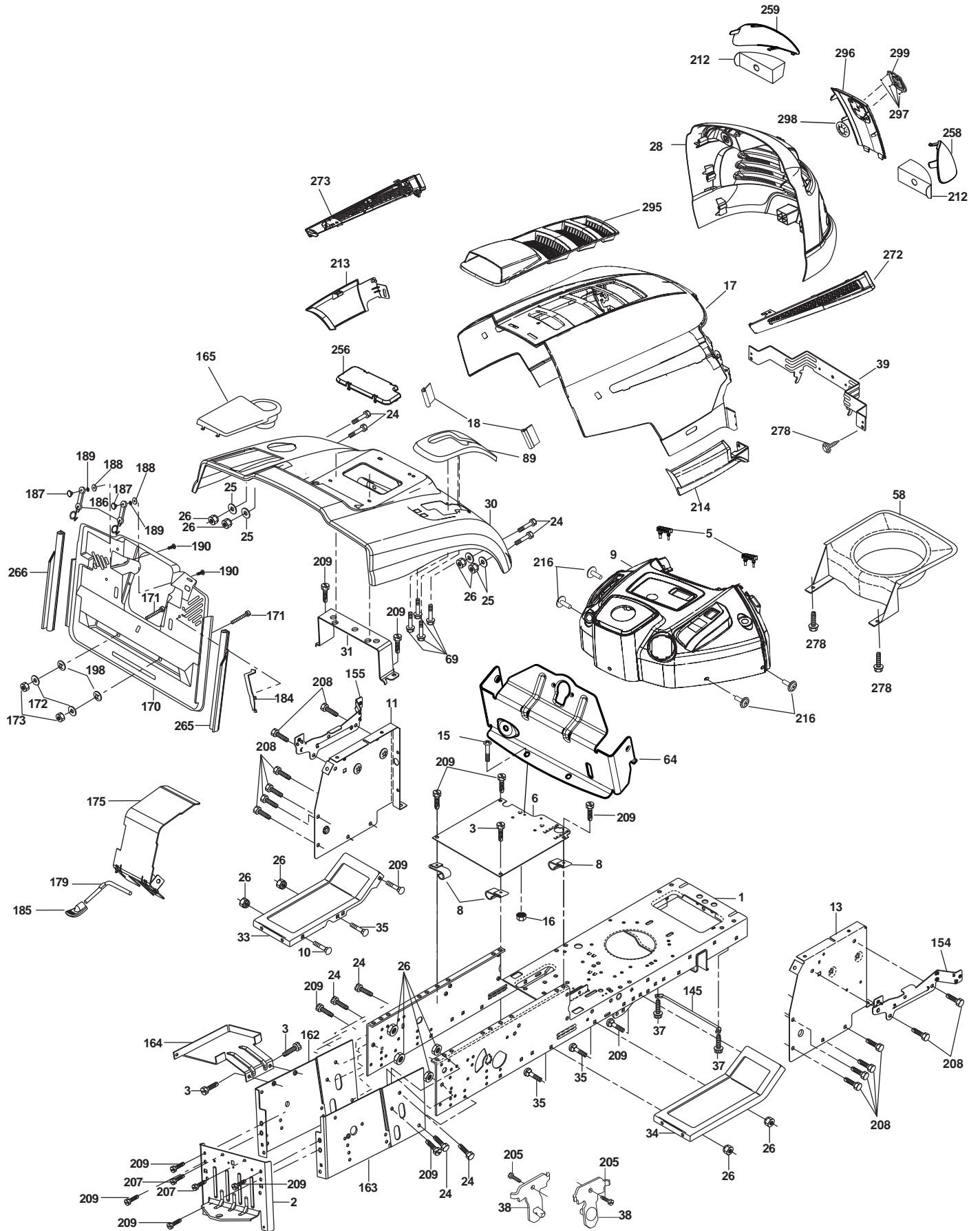

**TRACTOR- -MODEL NO. CT151 (96061018002) PRODUCT NO. 960 61 01-80  
CHASSIS AND ENCLOSURES**

<b>KEY NO.</b>	<b>PART NO.</b>	<b>DESCRIPTION</b>	<b>KEY NO.</b>	<b>PART NO.</b>	<b>DESCRIPTION</b>
1	532 17 46-20	Chassis	165	532 18 11-00	Cover Battery
2	532 18 03-84	Drawbar	170	532 19 94-88	Backplate CRD
3	817 06 06-12	Screw 3/8-16 x 3/4	171	872 14 06-20	Bolt Rdhd Sqnk 3/8-16 x 2-1/2 Gr. 5
5	532 40 75-90	Bumper Dash	172	819 13 20-16	Washer 13/32 x 1-1/4 x 16 Ga.
6	532 18 44-19	Saddle	173	873 51 06-00	Nut, Keps Hex 3/8-16 unc
8	532 12 64-71	Clip Insulator 13/32 Mtg. Hole	175	532 18 82-03	Door Trap
9	532 40 94-67	Dash	179	532 18 82-02	Rod Pivot FBI CRD
10	872 14 06-08	Bolt, Carriage 3/8-16 x 3/4	184	532 17 46-62	Bracket Actuator Bagger CRD
11	532 17 49-96	Panel, Dash, L.H.	185	532 18 11-01	Knob Rod Brake Parking
13	532 17 21-06	Panel, Asm. Dash R.H.	186	532 16 07-93	Latch Asm Mulch/Bagger
15	874 18 05-12	Screw, Machine, Truss Head 5/16-18 unc x 3/4	187	532 12 50-04	Nut Weld
16	873 51 05-00	Nut	188	819 06 12-16	Washer #10
17	532 41 10-73	Hood	189	810 07 10-00	Washer Lock #10
18	532 40 47-42	Bumper Hood/Dash	190	871 08 10-10	Screw Pan Hd Phillip 10-24 x 5/8
24	874 78 06-16	Bolt	198	532 16 89-37	Nut, Push
25	819 13 13-12	Washer 13/32 x 13/16 x 12 Ga.	205	817 49 06-08	Screw Thdrol 3/8-16 x 1/2
26	873 80 06-00	Nut	207	817 67 05-08	Screw Thdrl. 5/16-18 x 1/2
28	532 40 66-67	Grille /Lens Asm	208	817 67 06-08	Screw Thdrol 3/8-16 x 1/2
30	<b>532 19 73-76</b>	Fender	209	817 00 06-12	Screw Hex Wsh Thdrol 3/8-16
31	532 16 51-56	Bracket, Fender Support	212	532 40 66-65	Insert Lens Reflect
33	532 18 10-57	Footrest, L.H.	213	532 41 10-77	Skirt Side Husq. LH
34	532 18 10-58	Footrest, R.H.	214	532 41 10-76	Skirt Side Husq. RH
35	872 11 06-06	Bolt	216	817 67 04-12	Screw Thdrol 3/8-16 x 1/2
37	817 49 05-08	Screw Thdrol 5/16-18 x 1/2 TYT	256	532 18 13-61	Cover Fender Rack
38	532 18 17-48	Bracket Asm Pivot Mower Rear	258	532 41 10-78	Lens RH
39	532 40 78-07	Bracket Pivot	259	532 41 10-79	Lens LH
58	532 40 75-37	Duct Air Engine	265	532 18 57-04	Seal RH Side Bagger
64	532 40 81-27	Dash Lower W/INF	266	532 18 57-03	Seal LH Side Bagger
69	532 14 24-32	Screw HxWsh Hi-Lo	272	532 41 10-74	Vent Hood RH
89	532 19 74-07	Console CRD 6 Sp. 418	273	532 41 10-75	Vent Hood LH
145	532 15 65-24	Rod Pivot Chassis/Hood	278	532 19 16-11	Screw 10 x 3/4 Single Lead Hex
154	532 40 81-22	Brakcet MTG Dash RH	295	532 41 11-16	Vent Top
155	532 40 81-23	Bracket MTG Dash LH	296	532 41 11-19	Trim Husq.
162	532 18 03-82	Bracket Exten Chassis LH CRD	297	532 19 91-45	Clip Retainer
163	532 18 03-83	Bracket Exten Chassis RH CRD	298	532 11 04-52	Nut Push
164	532 16 56-05	Support Battery CRD	299	532 40 50-12	Logo. Husq
			--	532 41 11-15	Plug Dash SRVMNDR Tex

**NOTE:** All component dimensions given in U.S. inches.  
1 inch = 25.4 mm.



# TRACTOR- -MODEL NO. CT151 (96061018002) PRODUCT NO. 960 61 01-80 DRIVE

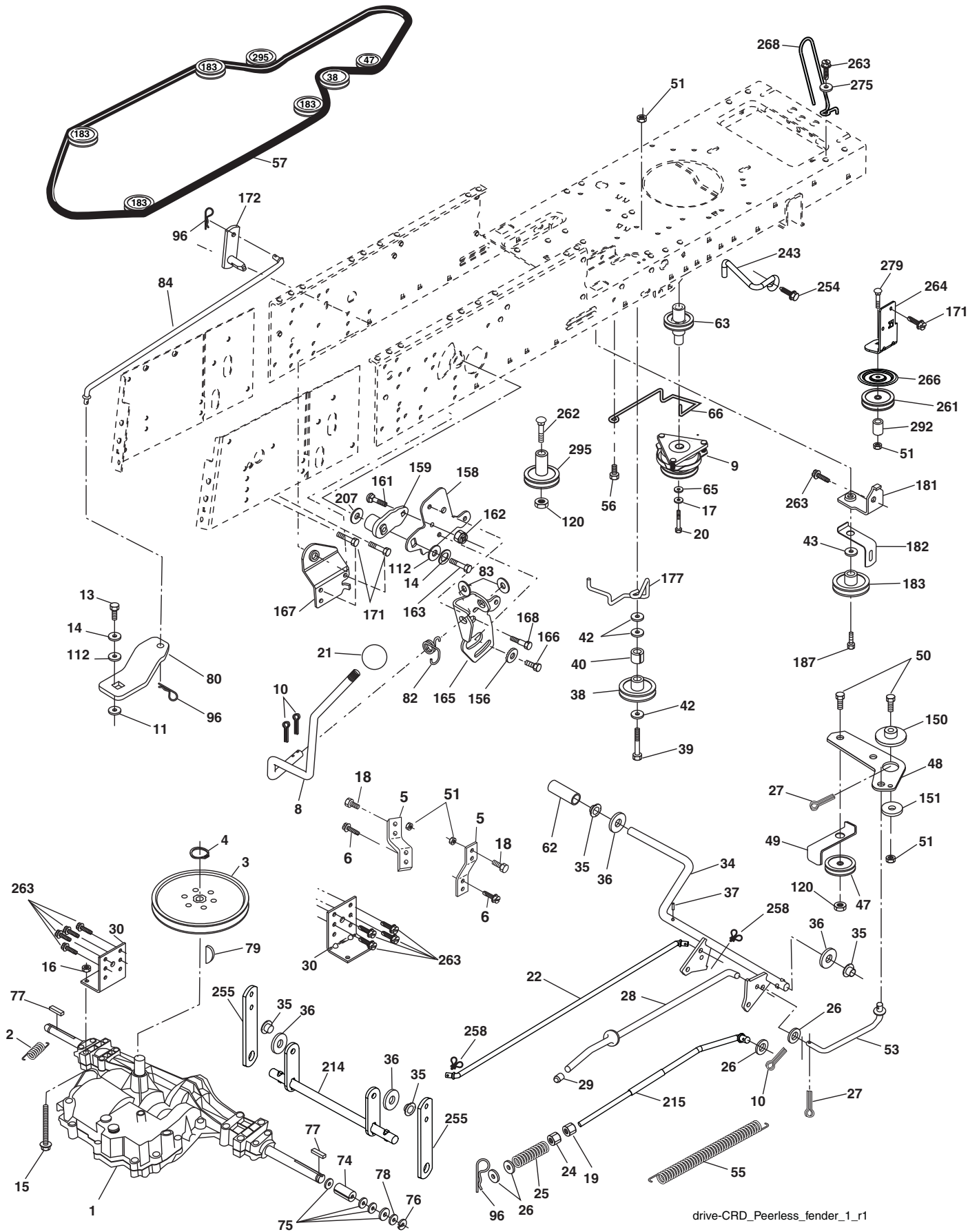

drive-CRD\_Peerless\_fender\_1\_r1

**TRACTOR- -MODEL NO. CT151 (96061018002) PRODUCT NO. 960 61 01-80  
DRIVE**

KEY NO.	PART NO.	DESCRIPTION	KEY NO.	PART NO.	DESCRIPTION
1	-----	Transaxle Peerless 206-546 (Order parts from transaxle manufacturer)	75	532 12 17-49	Washer 25/32 x 1-1/4 x 16 Ga.
2	532 14 66-82	Spring Brake Return	76	812 00 00-01	Ring, E
3	532 16 59-99	Pulley Transaxle	77	532 12 35-83	Key, Square
4	812 00 00-28	Ring Retainer #5100-62	78	532 12 17-48	Washer 25/32 x 1-5/8 x 16 Ga.
5	532 12 15-20	Strap Torque 30 degrees	79	532 12 50-96	Key Woodruff
6	817 06 05-12	Screw 5/16-18 x 3/4	80	532 14 50-90	Arm Shift PMST 20" Tires
8	532 19 27-06	Rod Shift	82	532 16 57-11	Spring, Torsion
9	532 19 81-43	Clutch Elect	83	819 17 12-16	Washer 17/32 x 3/4 x 16 Ga.
10	876 02 04-16	Pin, Cotter 1/8 x 1	84	532 16 56-21	Link Shift CRD
11	532 10 57-01	Washer Plate Shf .3888 sq hole	96	532 12 47-88	Spring, Retainer 1"
13	874 55 04-12	Bolt 1/4-28 unF Gr. 8 w/patch	112	819 09 12-10	Washer 9/32 x 3/4 x 10 Ga.
14	810 04 04-00	Washer, Lock Hvy Helical	120	873 90 06-00	Nut Lock Flg. 3/8-16 unc
15	874 49 05-44	Bolt Hex Flghd 5/16-18 Gr. 5	150	532 16 58-50	Bushing, Bellcrank Grnd Dr
16	873 80 05-00	Nut, Lock Hex w/lns 5/16-18 unc	151	819 13 32-10	Washer 13/32 x 2 x 10 Ga.
17	532 12 61 97	Washer 1-1/2 OD x 15/32	156	532 16 60-02	Washer Srrd 5/16 ID x 1.125
18	874 78 06-16	Bolt Hex 3/8-16 unc x 1 Gr. 5	158	532 16 55-89	Bracket Shift Mount
19	873 80 06-00	Nut, Lock Hex w/Wsh 3/8-16 unc	159	532 18 39-00	Hub Shift
20	532 17 39-37	Bolt Hex 7/16-20	161	872 14 04-06	Bolt Rdhd Sqnk 1/4-20 x 3/4 Gr. 5
21	532 12 12-74	Knob Duckhead	162	873 68 04-00	Nut Crownlock 1/4-20 unc
22	532 17 56-07	Rod, Brake CRD	163	874 78 04-16	Bolt Hex Fin 1/4-20 unc x 1 Gr. 5
24	873 35 06-00	Nut	165	532 16 56-23	Bracket Pivot Lever
25	532 10 68-88	Spring, Rod, Brake	166	817 49 05-10	Screw 5/16-18 x 5/8
26	819 13 13-16	Washer 13/32 x 13/16 x 16 Ga.	167	532 16 55-88	Bracket Support Shift CRD
27	876 02 04-12	Pin, Cotter 1/8 x 3/4	168	532 16 54-92	Bolt Shoulder 5/16-18 x .561
28	532 17 57-65	Rod, Parking Brake	171	817 49 06-08	Screw Thdrol 3/8-16 x 1/2 Ty-Tt
29	532 12 42-36	Cap Brake Parking	172	532 16 56-35	Shaft Asm Shift Front CRD
30	532 17 49-73	Bracket, Mfg. Transaxle	177	532 16 59-32	Keeper Flat Idler 3.06" CRD
34	532 17 55-78	Shaft, Asm Pedal Foot	181	532 18 02-11	Bracket Idler Ground Drive CRD
35	532 12 01-83	Bearing, Nylon	182	532 18 26-82	Keeper Belt 2.5" OD V-Idler CRD
36	819 21 16-16	Washer 21/32 x 1 x 16 Ga.	183	532 19 95-32	Pulley V-Idler
37	532 12 49-63	Pin, Roll 3/16 x 1"	187	817 58 05-20	Screw 5/16-18 x 1.25
38	532 16 59-36	Pulley, Flat	207	532 16 98-45	Washer Nylon Rear
39	874 76 06-44	Bolt Fin Hex 3/8-16 unc x 2-3/4	214	532 17 56-09	Shaft Asm Blade
40	532 12 49-65	Spacer, Split 395 x 59 Bzp	215	532 41 01-42	Rod Brake Secondary
42	819 13 13-12	Washer 13/32 x 13/16 x 12 Ga.	243	532 19 07-36	Bracket Anti Rotation
43	819 11 10-12	Washer 11/32 x 5/8 x 12 Ga.	254	817 00 06-16	Screw 3/8-16 x 1
47	532 12 77-83	Pulley, Idler, V Groove Plasic	255	532 17 56-08	Brace Shaft Brake Mtg.
48	532 15 44-07	Bellcrank Clutch Grnd Drv	258	532 17 80-62	Clip Retainer
49	532 12 32-05	Retainer, Belt Style Spring	261	532 13 14-94	Pulley Idler
50	872 11 06-12	Bolt 3/8-16 unc x 1-1/2	262	872 11 06-22	Bolt Rdhd 3/8-16 unc x 2-3/4 Gr. 5
51	873 68 06-00	Nut, Crownlock 3/8-16 unc	263	817 00 06-12	Screw 3/8-16 x 3/4
53	532 19 96-52	Link, Clutch 7.66	264	532 19 76-07	Bracket Idler
55	532 10 57-09	Spring, Return, Clutch	266	532 18 20-61	Shield Idler Mower
56	817 06 06-20	Screw 3/8-16 x 1-1/4	268	532 18 24-02	Guard Muffler RH
57	532 16 56-31	V-Belt Drive	275	819 13 16-14	Washer 13/32 x 1 x 14 Ga.
62	532 12 48-72	Cover, Pedal	279	872 11 06-16	Bolt RD HD SQNK 3/8-16 unc x 2
63	532 18 03-97	Pulley Engine	292	532 40 02-71	Spacer
65	810 04 07-00	Washer	295	532 17 91-14	Pulley Idler
66	532 15 47-78	Keeper, Belt Engine F-Proof			
74	<b>532 13 70-57</b>	Spacer Axle			

**NOTE:** All component dimensions given in U.S. inches  
1 inch = 25.4 mm

# TRACTOR- -MODEL NO. CT151 (96061018002) PRODUCT NO. 960 61 01-80 ENGINE

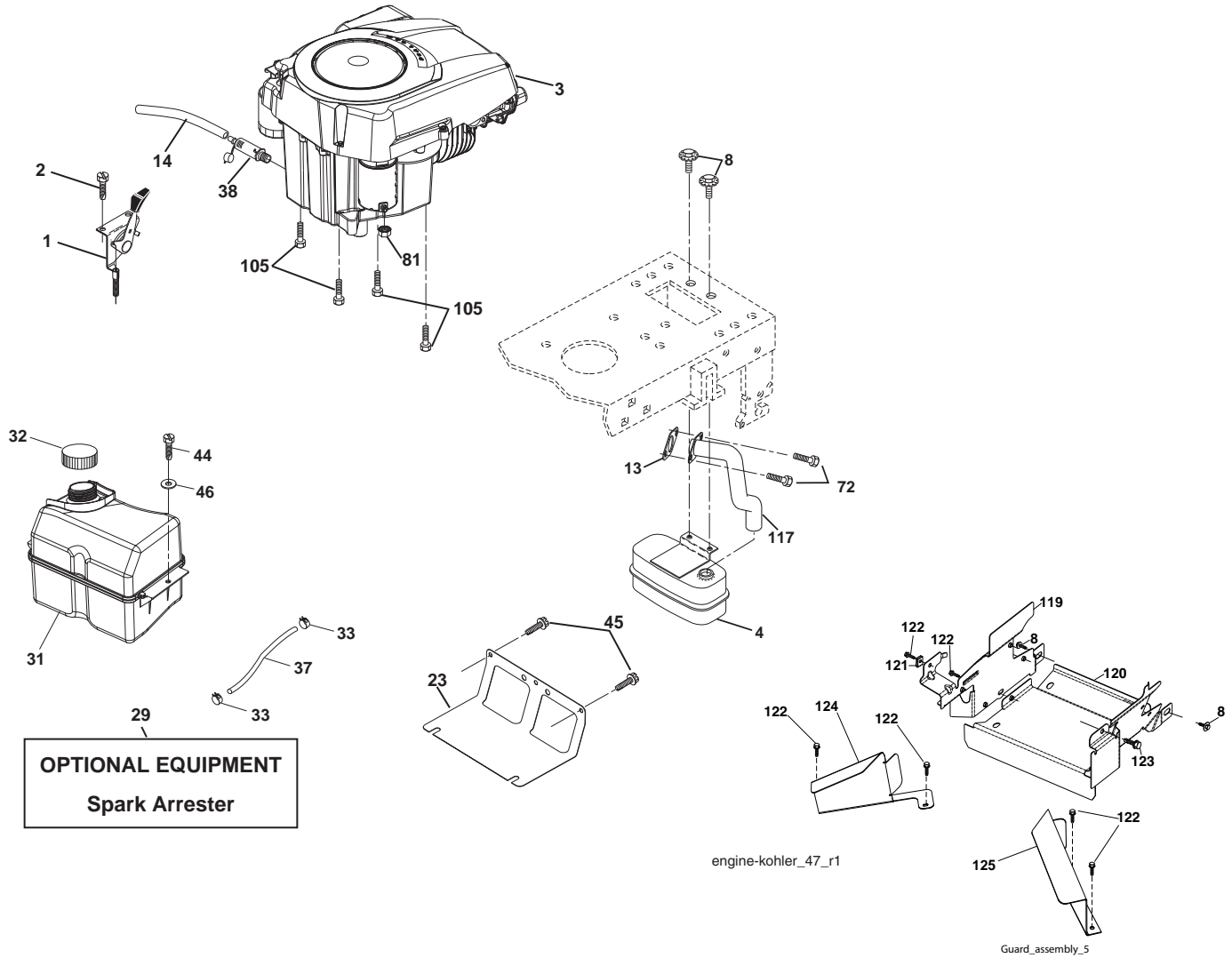

KEY NO.	PART NO.	DESCRIPTION
1	532 18 38-97	Control Throt /Ch Flag
2	532 19 16-11	Screw 10 x 3/4
3	-----	Engine Kohler SV470 (Order Parts from Engine Manufacturer)
4	532 18 86-55	Muffler Exhaust
8	532 17 18-77	Bolt 5/16-18 x 3/4
13	532 18 59-09	Gasket
14	532 14 84-56	Tube Drain Oil Easy
23	532 16 98-37	Shield Browning/Debris Guard
29	532 13 71-80	Arrestor Spark
31	532 40 75-45	Tank Fuel
32	532 19 77-25	Cap Asm Fuel Top
33	532 12 34-87	Clamp Hose Blk
37	532 13 70-40	Line Fuel 20"

KEY NO.	PART NO.	DESCRIPTION
38	532 18 16-54	Plug Drain Oil Easy
44	817 67 04-12	Screw Hexwsh Thdrol 1/4-20 x 3/4
45	817 00 06-12	Screw Hexwsh Thdr 3/8-16 x 3/4
46	819 09 14-16	Washer 9/32 x 7/8 x 16 Ga
72	<b>532 19 23-34</b>	Screw Socket Head 5/16-18 x .75
81	873 51 04-00	Nut Keps 1/4-20 unc
105	817 12 06-16	Screw 3/8-16 x 1
117	532 18 86-54	Tube Exhaust
119	532 19 97-68	Guard Engine LH
120	532 19 97-67	Guard Engine RH
121	532 19 66-88	Clips
122	532 13 77-29	Screw Thdrol 1/4-20 x 5/8
123	817 67 05-08	Screw Thdrol 5/16-18 x 1/2
124	532 41 05-24	Shield Side LH
125	532 41 05-25	Shield Side RH

**NOTE:** All component dimensions given in U.S. inches.  
1 inch = 25.4 mm

# TRACTOR- -MODEL NO. CT151 (96061018002) PRODUCT NO. 960 61 01-80 SEAT ASSEMBLY

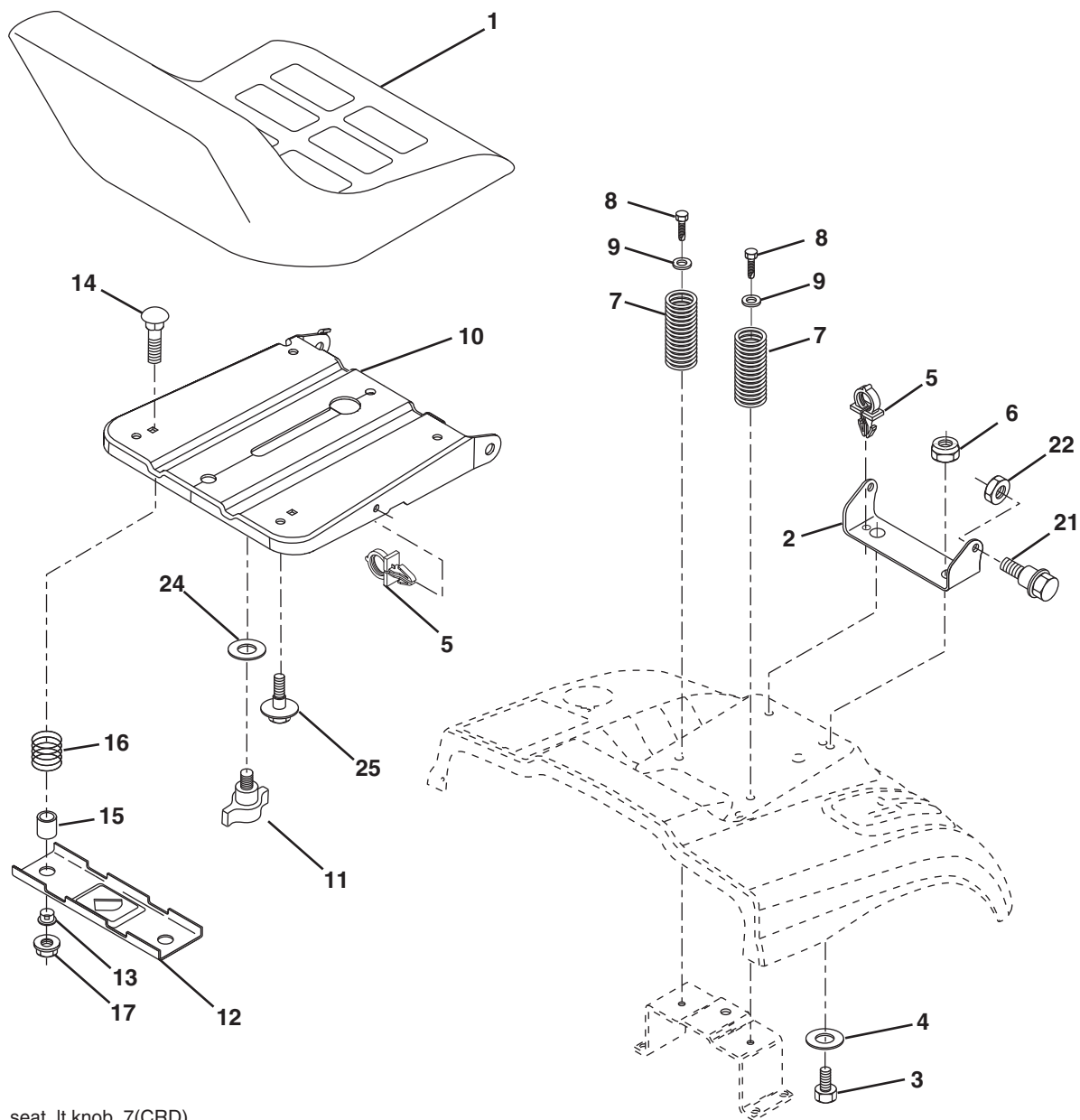

seat\_lt.knob\_7(CRD)

KEY NO.	PART NO.	DESCRIPTION
1	532 19 01-20	Seat
2	532 14 05-51	Bracket Pnt Pivot Seat (blk )
3	871 11 06-16	Bolt Fin Hex 3/8-16 x 1
4	819 13 16-10	Washer Flat 13/32 x 1 x 10 Ga.
5	532 14 50-06	Clip Push In Hinged
6	873 80 06-00	Nut Lock Hx w/Ins. 3/8-16
7	532 12 41-81	Spring Seat Cprsn 2 250 Blk Zi
8	817 00 06-16	Screw 3/8-16 x 1-1/2
9	819 13 16-14	Washer 13/32 x 1 x 14 Ga.
10	532 19 55-30	Pan Pnt Seat
11	532 16 63-69	Knob Seat Adj. Wingnut
12	532 17 46-48	Bracket Pnt Mounting Switch

KEY NO.	PART NO.	DESCRIPTION
13	532 12 12-48	Bushing Snap Blk Nyl 50 Id
14	872 05 04-12	Bolt Rdhd Sht Nk 1/4-20 x 1-1/2
15	532 13 43-00	Spacer Split
16	532 12 12-50	Spring Cprsn Plate SW 1.310 Ga.
17	532 12 39-76	Nut Lock 1/4 Lge Flg Gr 5 Zinc
21	532 17 18-52	Bolt Shoulder 5/16-18 unc-2A
22	873 80 05-00	Nut Hex Lock w/Ins 5/16-18
24	819 17 19-12	Washer 17/32 x 1-3/16 x 12 Ga.
25	532 12 70-18	Bolt Shoulder 5/16-18 x 62

**NOTE:** All component dimensions given in U.S. inches.  
1 inch = 25.4 mm

**TRACTOR- -MODEL NO. CT151 (96061018002) PRODUCT NO. 960 61 01-80**  
**STEERING ASSEMBLY**

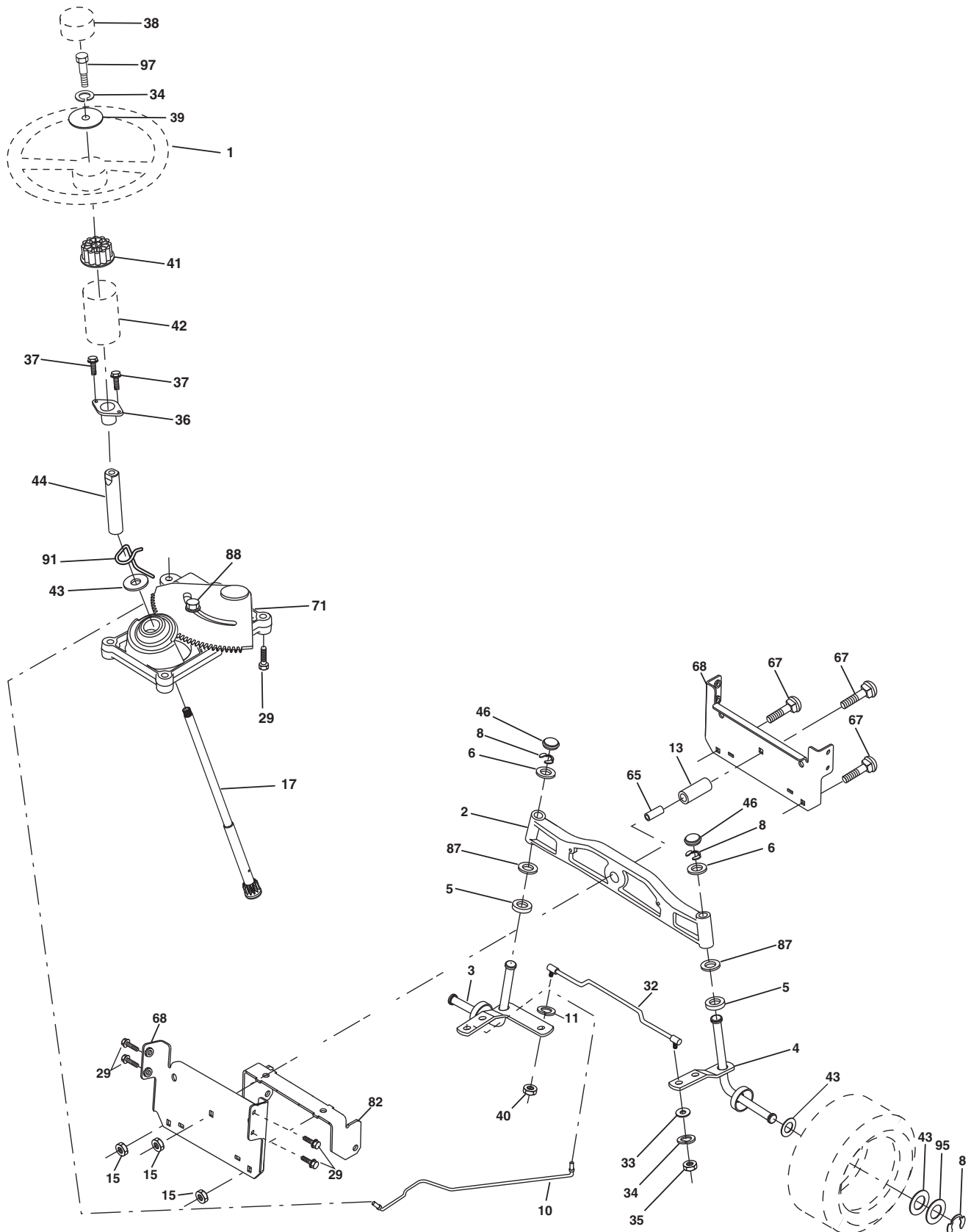

steering\_pl.it\_60

**TRACTOR- -MODEL NO. CT151 (96061018002) PRODUCT NO. 960 61 01-80  
STEERING ASSEMBLY**

<b>KEY NO.</b>	<b>PART NO.</b>	<b>DESCRIPTION</b>
1	532 19 36-51	Steering Wheel
2	532 18 47-06	Axle Asm Cast Iron Lt
3	532 16 98-40	Spindle Assembly, LH
4	532 16 98-39	Spindle Assembly, RH
5	532 12 49-31	Bearing, Race, Thrust, Hardened
6	532 12 17-48	Washer 25/32 x 1-5/8 x 16 Ga.
8	812 00 00-29	Ring, Klip
10	532 17 51-21	Link, Drag
11	810 04 06-00	Washer, Lock
13	532 13 65-18	Spacer Brg Axle Front
15	532 14 52-12	Nut Hex Flange Lock
17	532 19 07-53	Shaft, Steering
29	817 00 06-12	Screw 3/8-16 x 3/4
32	532 17 18-88	Rod, Tie
33	819 11 12-16	Washer 11/32 x 3/4 x 16 Ga.
34	810 04 05-00	Washer Lock Hvy Hlcl Spr 5/16
35	873 54 05-00	Crownlock Nut 5/16-24 unf 3847
36	532 15 50-99	Bushing, Steering
37	532 15 29-27	Screw TT #10-32 x 5 x 3/8 Flange
38	532 19 36-52	Cap Wheel Steering
39	819 11 38-12	Washer 11/32 ID x 2- 3/8 OD x 12 Ga.
40	873 54 06-00	Nut Lock 3/8-24
41	532 18 67-37	Adaptor, Steering Wheel
42	532 41 11-39	Boot, Steering Dash
43	532 12 17-49	Washer 25/32 x 1-1/4 x 16 Ga.
44	532 19 07-52	Extension Steering Shaft
46	532 12 12-32	Cap, Spindle
65	532 16 03-67	Spacer Brace Axle
67	872 11 06-18	Bolt Rdhd Sqnk 3/8-16 x 2-1/4
68	532 16 98-27	Brace Axle
71	532 17 51-46	Steering Asm.
82	532 19 99-78	Bracket Susp Chassis Front
87	532 17 39-66	Washer Flat .781 x 1-1/2 x .14
88	532 17 51-18	Bolt Shoulder 7/16-20 unc
91	532 17 55-53	Clip Steering
95	532 18 89-67	Washer
97	874 78 05-64	Bolt 5/16-18 unc x 4" L. Gr. 5

**NOTE:** All component dimensions given in U.S. inches.  
1 inch = 25.4 mm.

TRACTOR- -MODEL NO. CT151 (96061018002) PRODUCT NO. 960 61 01-80  
MOWER

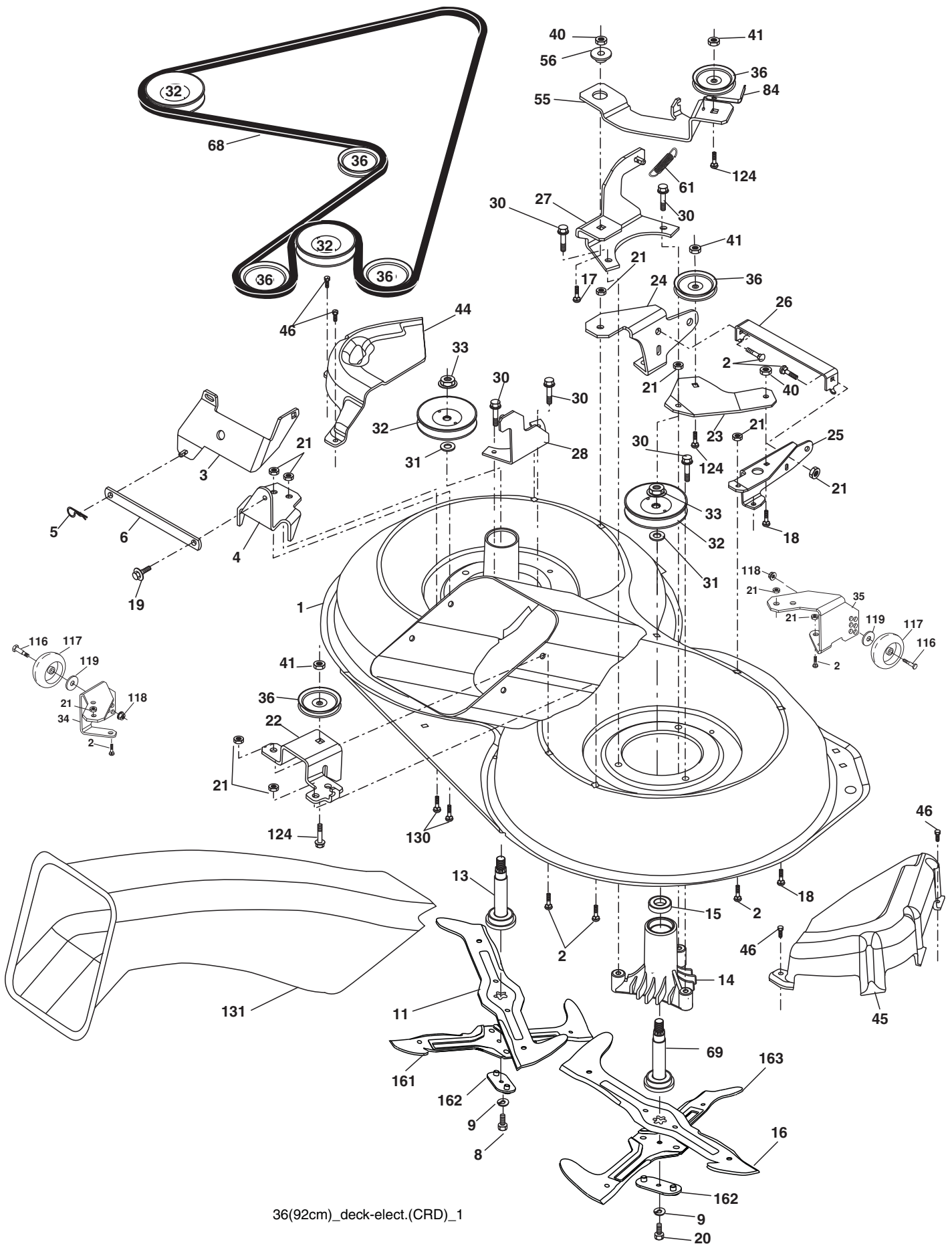

36(92cm)\_deck-elect.(CRD)\_1

**TRACTOR- -MODEL NO. CT151 (96061018002) PRODUCT NO. 960 61 01-80  
MOWER**

<b>KEY NO.</b>	<b>PART NO.</b>	<b>DESCRIPTION</b>	<b>KEY NO.</b>	<b>PART NO.</b>	<b>DESCRIPTION</b>
1	532 40 01-08	Housing Asm. Mower 92 CRD	35	532 40 01-06	Bracket Gauge Wheel Rf 92 CRD
2	872 14 05-06	Bolt Rdhd Sqnk 5/16-18 unc x 3/4	36	532 14 67-63	Pulley Idler V-Groove Dim 4.25
3	532 16 55-69	Bracket Asm. S-Bar Chass 92 CRD	40	873 68 06-00	Nut Crownlock 3/8-16 unc
4	532 16 55-58	Bracket Bar Sway Deck 92 CRD	41	873 90 06-00	Nut Lock Flg. 3/8-16 unc
5	532 12 46-70	Retainer Spring	44	532 17 55-38	Cover Mandrel Lh 92 CRD
6	532 16 55-57	Bar Sway 92 CRD	45	532 17 55-39	Cover Mandrel Rh 92 CRD
8	532 18 17-12	Bolt 3/8-24 x 1.25 Gr. 8 Patched	46	532 13 77-29	Screw Thd Roll 1/4-20 x 5/8
9	810 03 06-00	Washer Lock Hvy 3/8 Unplated	55	532 19 94-98	Arm Idler 92 CRD
11	532 18 63-85	Blade 3-1 Lh 92 CRD	56	532 16 57-23	Spacer Retainer Mower
13	532 13 76-45	Shaft Asm. W/Lower Bearing	61	532 19 94-86	Spring Tension Belt
14	532 12 87-74	Housing Mandrel Vented (Machd)	68	532 40 20-08	Hex-Belt 92 Mower
15	532 11 04-85	Bearing Ball Mandrel	69	532 16 54-82	Shaft Asm W/Lwr Brg Rh Thd CRD
16	532 18 63-86	Blade 3-1 Rh 92 CRD	84	532 15 60-85	Keeper Belt Idler
17	872 14 06-10	Bolt Carriage 3/8-16 x 1-1/4	116	532 19 34-06	Bolt Shoulder
18	872 11 06-06	Bolt Rdhd Sqnk 3/8-16 x 3/4	117	532 17 48-73	Wheel Gage
19	532 13 28-27	Bolt Shoulder 5/16-18 Thd Form	118	873 90 06-00	Nut Centerlock 3/8-16 unc
20	532 18 17-13	Bolt 3/8-24 x 1.25 Gr. 8 Ptch Lhthd	119	819 13 20-12	Washer 13/32 x 1-1/4 x 12
21	873 68 05-00	Nut Crown Lock 5/16-18	124	872 11 06-12	Bolt Carr Sh 3/8-16 x 1-1/2 Gr. 5
22	532 19 95-90	Bracket Idler Sprt 92 CRD	130	872 11 05-06	Bolt Rdhdsqnk 5/16-18 unc x 3/4
23	532 16 54-46	Bracket Idler Sprt RF 92 CRD	131	532 16 56-61	Chute Bagger CRD 92cm
24	532 16 52-42	Bracket Suspension LF 92 CRD	161	<b>532 18 63-87</b>	Blade Cross LH
25	532 16 52-44	Bracket Suspension RF 92 CRD	162	<b>532 18 05-24</b>	Adapter Blade
26	532 40 01-10	Brace Susp Frt CRD	163	<b>532 18 63-88</b>	Blade Cross RH
27	532 16 55-68	Bracket Asm. Susp RR 92 CRD	--	532 18 18-57	Mandrel Asm Service
28	532 16 55-67	Bracket Asm. Susp LR 92 CRD	--	532 18 18-58	Mandrel Asm CRD LH Threads SVC
30	532 17 39-84	Screw Thd Rolling	--	532 40 84-12	Replacement Mower, Complete (Std. Deck - Order separately guage wheel components key nos. 116 - 119)
31	532 18 76-90	Washer Spacer Mower Vented			
32	<b>532 17 57-07</b>	Mandrel Pulleys			
33	532 40 02-34	Nut Flg Top Lock			
34	532 40 01-07	Bracket Gauge Wheel Lf 92 CRD			

**NOTE:** All component dimensions given in U.S. inches  
1 inch = 25.4 mm



TRACTOR- -MODEL NO. CT151 (96061018002) PRODUCT NO. 960 61 01-80  
MOWER LIFT

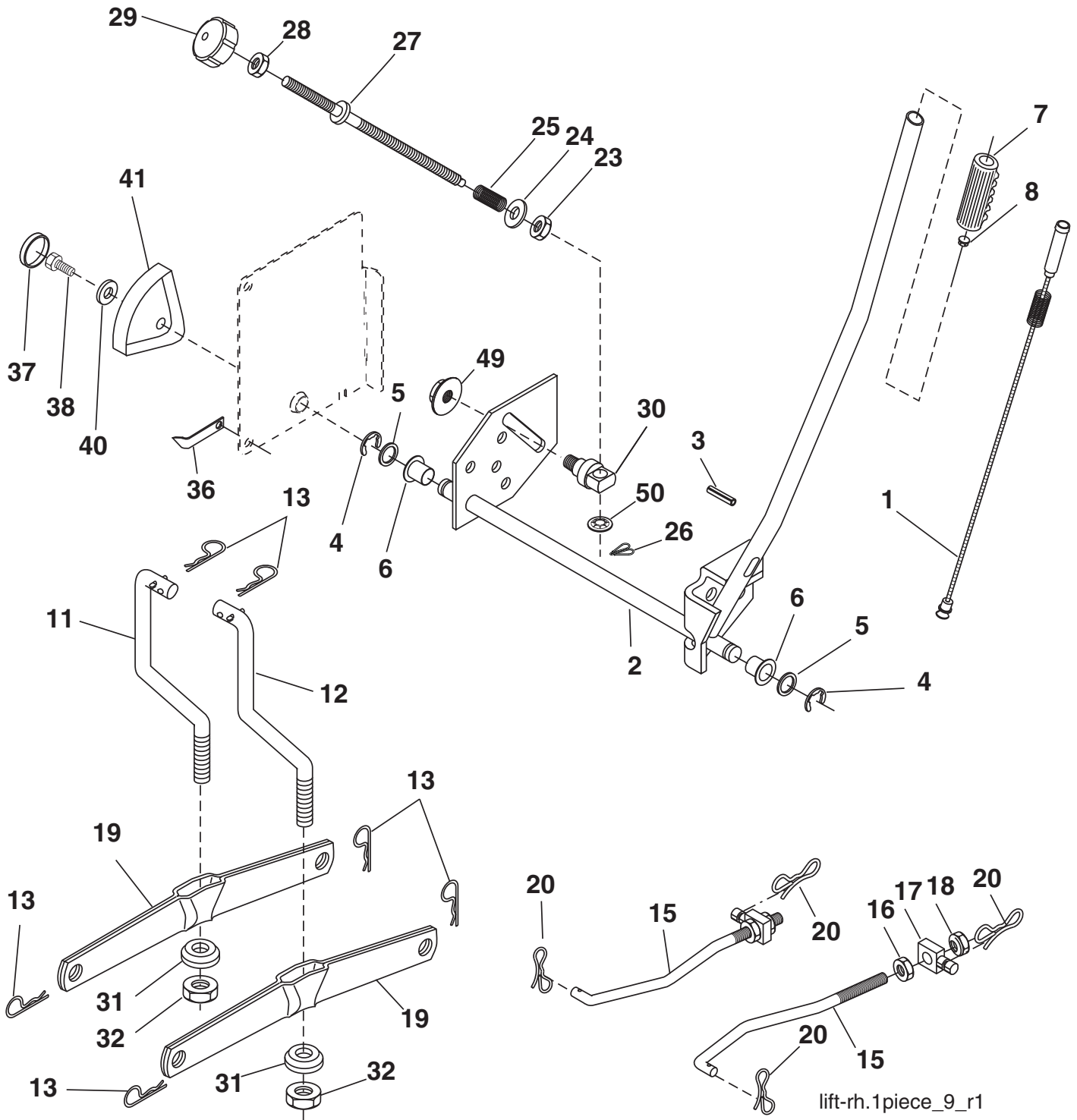

**TRACTOR- -MODEL NO. CT151 (96061018002) PRODUCT NO. 960 61 01-80  
MOWER LIFT**

<b>KEY NO.</b>	<b>PART NO.</b>	<b>DESCRIPTION</b>
1	532 15 94-60	Wire Asm Inner Spring W/Plunger
2	532 15 94-71	Shaft Asm. Lift
3	532 10 57-67	Pin Groove
4	812 00 00-02	E Ring #5133-62
5	819 21 16-21	Washer 21/32 x 1 x 21 Ga.
6	532 12 01-83	Bearing Nylon
7	532 12 56-31	Grip Handle
8	532 12 23-65	Button Plunger Red
11	532 16 58-29	Link Lift LH
12	532 16 58-31	Link Lift RH
13	532 12 46-70	Retainer Spring
15	532 17 32-88	Link Front
16	873 35 08-00	Nut Jam Hex 1/2-13 unc
17	532 17 56-89	Trunnion
18	873 80 08-00	Nut Lock W/Wsh 1/2-13 unc
19	532 13 98-68	Arm Suspension Mower
20	532 19 42-09	Pin Cotter 7/16 Bow Tie Lock
23	532 11 08-07	Nut Special
24	819 13 10-16	Washer 13/32 x 5/8 x 16 Ga.
25	532 16 40-24	Spring 2-1/8
26	532 16 94-84	Retainer Clip
27	532 16 45-43	Rod Adj Lift Zinc
28	873 35 06-00	Nut Hex Jam 3/8-16 unc
29	532 13 80-57	Knob Inf 3/8-16 unc
30	532 15 02-33	Trunnion Infin Height
31	532 16 98-65	Bearing, Pvt. Lift.
32	873 54 06-00	Nut Crownlock 3/8-24
36	532 15 50-97	Pointer Height Indicator
37	532 12 39-35	Plug Hole Blk
38	817 06 05-16	Screw 5/16-18 x 1
40	819 11 24-10	Washer 11/32 x 1-1/2 x 10 Ga.
41	532 12 39-34	Scale Ind Height Blk
49	532 14 52-12	Nut Hex Flange Lock
50	532 11 04-52	Nut Push Phos &Oil

**NOTE:** All component dimensions given in U.S. inches.  
1 inch = 25.4 mm

**TRACTOR- -MODEL NO. CT151 (96061018002) PRODUCT NO. 960 61 01-80  
BAGGER**

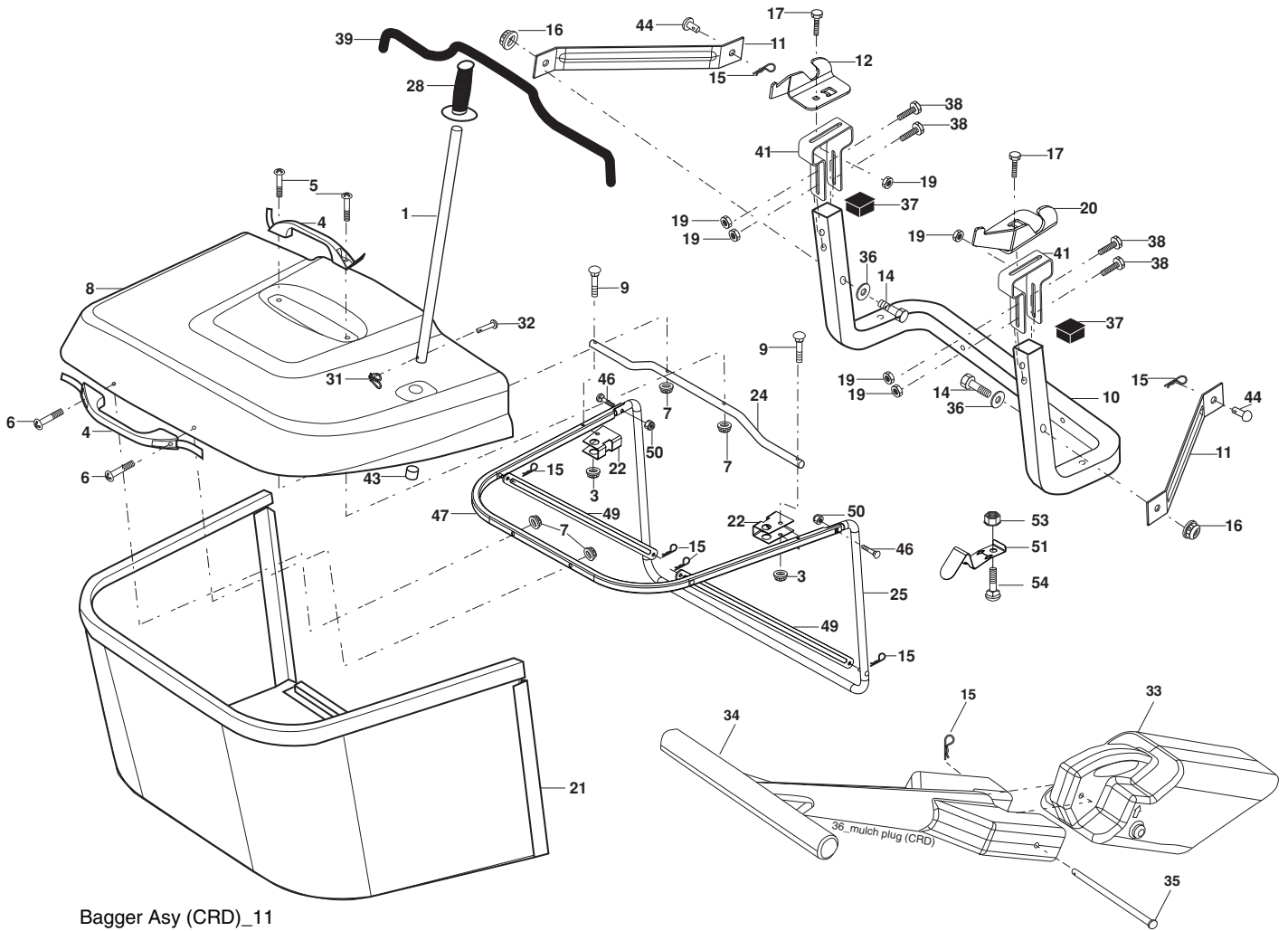

Bagger Asy (CRD)\_11

**TRACTOR- -MODEL NO. CT151 (96061018002) PRODUCT NO. 960 61 01-80  
BAGGER**

<b>KEY NO.</b>	<b>PART NO.</b>	<b>DESCRIPTION</b>
1	532 16 52-49	Tube Handle Bagger CRD
3	532 12 39-76	Nut Lock 1/4 Lge Flg Gr. 5 Zinc
4	532 16 99-16	Handle Bagger w/Lvrs Blk CRD
5	874 98 10-24	Screw Pan Head #10-24 x 1.50 Blk
6	874 98 10-32	Screw Pan Hd
7	873 40 10-00	Nut Wiz Lock Hex Serr/Hd 10-24
8	532 18 10-95	Cover Bagger CRD MS422
9	872 14 04-18	Bolt Carriage 1/4-20 x 2.25d x Gr. 5
10	532 18 12-82	Tube Support Bagger CRD
11	532 16 57-19	Bracket Support Upper Bag CRD
12	532 18 88-48	Bracket Pivot Lh
14	874 52 06-36	Bolt Carr.
16	873 90 06-00	Nut Lock Flg. 3/8-16 unc
15	532 12 46-70	Retainer Spring
17	872 14 05-06	Bolt Rdhd Sht Sqnk 5/16 -18 unc x 3/4
19	873 90 05-00	Nut Lock Hexflange 5/16-18
20	532 18 88-47	Bracket Pivot Rh
21	532 40 61-80	Bag Asm CRD
22	532 16 57-81	Bracket Side Bagger CRD
24	532 16 57-83	Tube Pivot Bagger CRD
25	532 19 37-05	Tube Front Bagger CRD
28	532 16 57-87	Grip Handle Black
31	532 16 94-84	Retainer Clip
32	532 12 68-75	Rivet Rd Hd Drilled 3/8 Dia
33	532 16 55-71	Plug Mulcher 92 CRD
34	532 16 55-70	Handle Mulcher 92/107 CRD
35	532 16 55-72	Pin Mulcher 92/107 CRD
36	819 13 20-12	Washer 13/32 x 1-1/4 x 12 Ga.
37	532 17 54-01	Plug Support Bagger CRD
38	872 01 05-20	Bolt 5/16-18 x 2-1/2
39	532 18 09-85	Seal 37"
41	532 16 96-83	Bracket Vert Adj Bagger CRD
43	532 17 40-83	Plug Tubing
44	532 19 33-12	Pin Clevis
46	872 11 05-10	Bolt Carr. 5/16-18 x 1-1/4 Gr. 5
47	532 19 37-04	Tube Upper Bagger
49	532 19 33-05	Bar Spreader
50	873 80 05-00	Nut Lock Thx w/Ins. 5/16-18 unc
51	532 19 99-03	Latch Spring Bagger
53	873 51 04-00	Nut Keps Hex 1/4-20 unc
54	872 14 04-06	Bolt Rdhd Sqnk 1/4-20 x 3/4 Gr. 5

**NOTE:** All component dimensions given in U.S. inches  
1 inch = 25.4 mm