

# CTH150 Twin

**Spare parts**

**Ersatzteile**

**Pièces détachées**

**Reserve onderdelen**

**Repuestos**

**Reservdelar**

# ILLUSTRATED PARTS LIST

**MFG. ID NO. 96061018100**

**CUSTOMER CATALOG NO. CTH150TWIN**

**PRODUCT NO. 960 61 01-81**

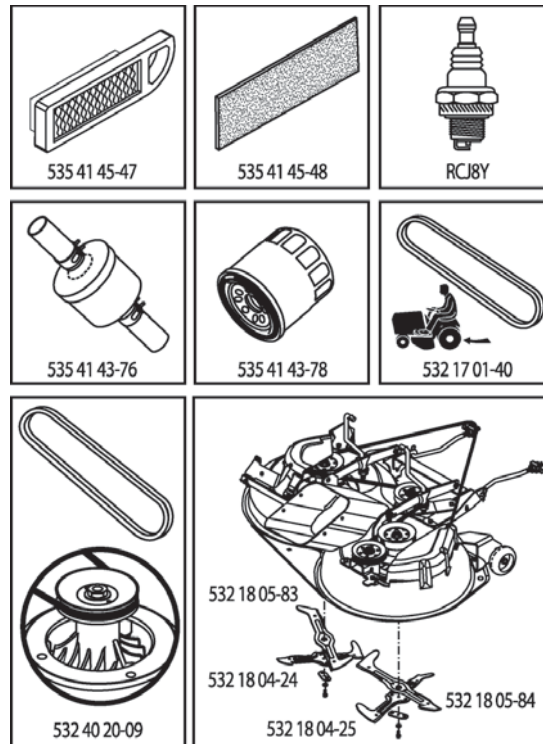

**47**

409659

**TRACTOR -- MODEL NO. CTH150TWIN (96061018100), PRODUCT NO. 960 61 01-81  
DECALS 27**

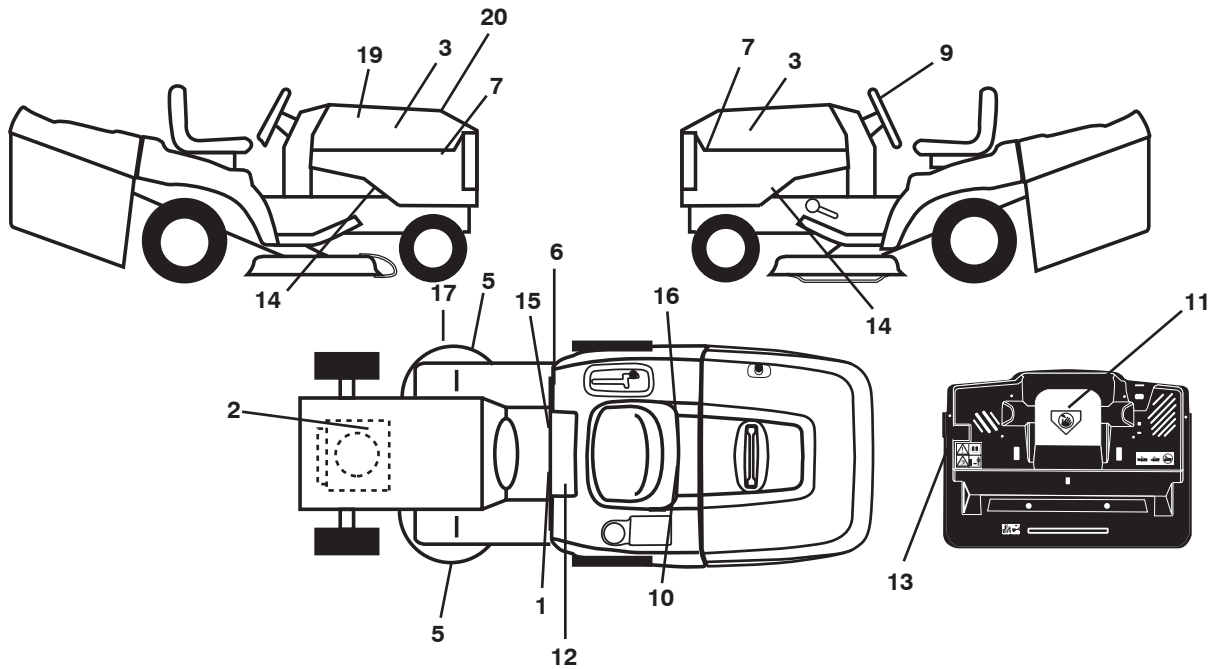

KEY NO.	PART NO.	DESCRIPTION
1	532 40 03-89	Decal, Warning Syms. CE
2	532 19 68-41	Decal, Warning Eng. Sym.
3	532 40 28-32	Decal, Hood
5	532 19 68-42	Decal, Sdl Shf/CRD Sym Cutfingr
6	532 18 04-32	Decal, 100 DBA/CE
7	532 41 05-47	Decal, Panel Side
9	532 40 44-84	Decal, Ins Strg Whl
10	532 14 50-05	Decal, Bat Dan/Poi P/L Sym Wpnr
11	532 18 21-66	Decal, Mower Cut Finger Symbol
12	532 15 97-37	Decal, Brake/Clutch Symbol Lt
13	532 18 04-35	Decal, Rear Plate CRD

KEY NO.	PART NO.	DESCRIPTION
14	532 15 97-36	Decal, Chassis Hot Muffler
15	532 14 08-37	Decal, Saddle Brake Parking
16	532 16 69-60	Decal, Bypass Fender CRD
17	532 16 62-86	Decal, Hex Belt Sch CRD
19	532 40 96-59	Decal, Replacement
20	532 40 21-28	Decal Hood Top
--	532 18 19-16	Pad Footrest LH
--	532 18 19-17	Pad Footrest RH
--	532 40 90-81	Manual Operator's (Euro)
--	532 40 90-82	Manual Operator's (Scan)
--	532 40 90-83	Manual Operator's (E-Bloc)
--	532 40 90-84	Manual Operator's (Baltic)

**WHEELS & TIRES**

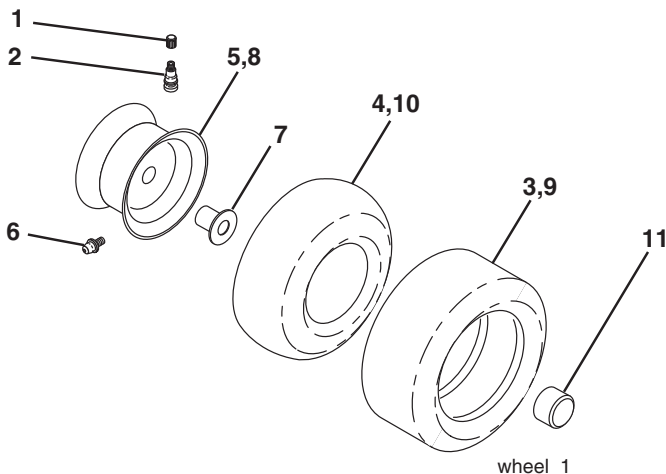

KEY NO.	PART NO.	DESCRIPTION
1	532 05 91-92	Cap Valve Tire
2	532 06 51-39	Stem Valve
3	532 10 62-22	Tire F Ts 15 x 6 0 - 6 Service
4	532 05 99-04	Tube Inner Front #35060
5	532 13 83-36	Rim Asm 6"Front Silver Service
6	532 12 49-57	Fitting Grease
7	532 12 49-59	Bearing Flange
8	532 13 83-37	Rim Asm 8"Rear Silver Service
9	532 12 20-82	Tire R Ts 20 x 10-8 Service
10	532 12 49-26	Tube Rear 9 5 x 8 Service
11	532 17 50-39	Cap Axle Blk 1 50 x 1 00
--	532 14 43-34	Sealant, Tire (10 oz. tube)

**NOTE:** All component dimensions given in U.S. inches  
1 inch = 25.4 mm

**TRACTOR -- MODEL NO. CTH150TWIN (96061018100), PRODUCT NO. 960 61 01-81  
SCHEMATIC 38**

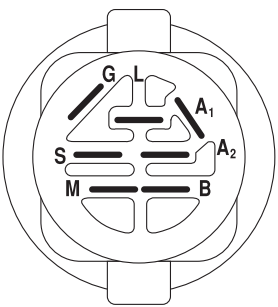
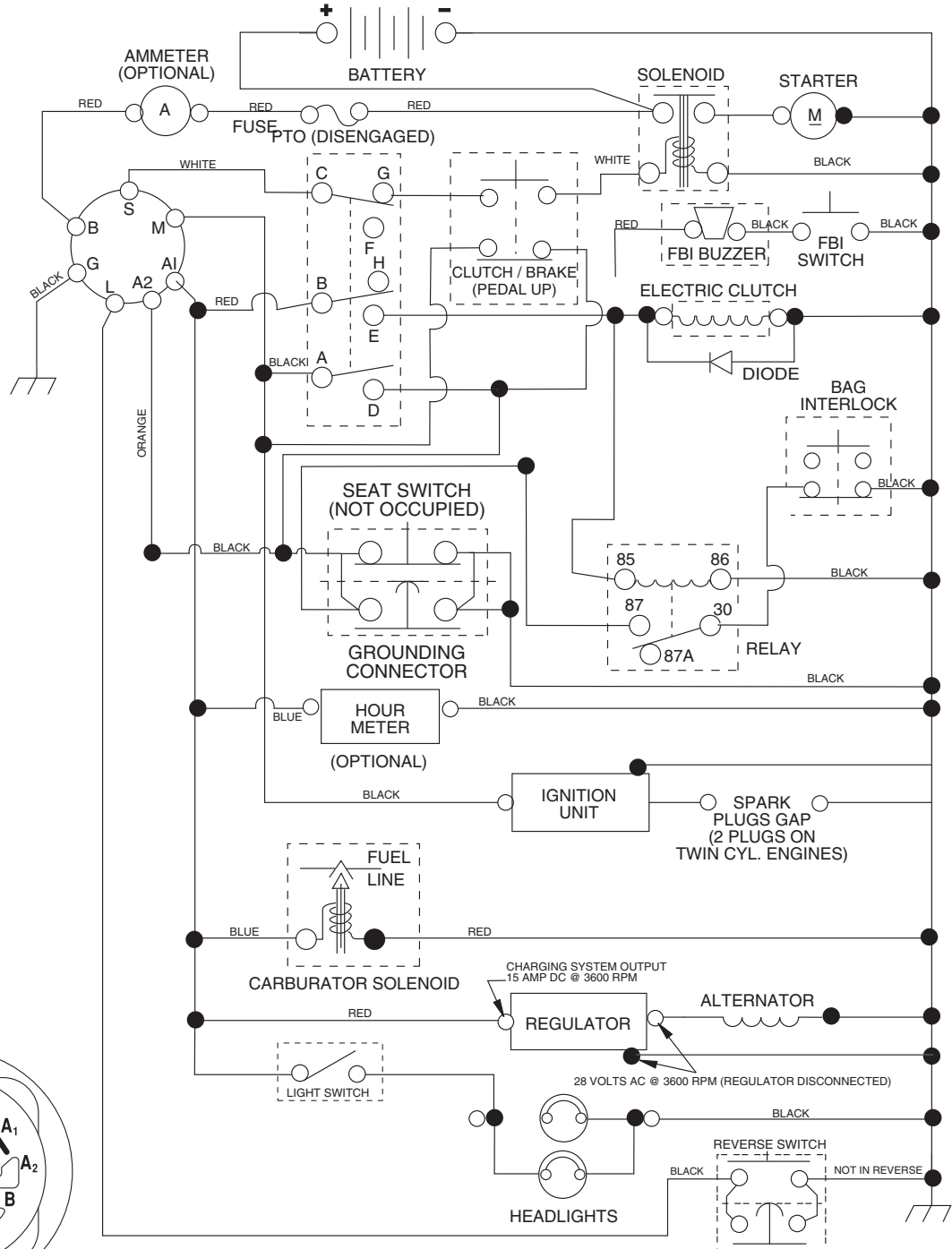

**IGNITION SWITCH**

POSITION	CIRCUIT "MAKE"
OFF	M+G+A1
RUN/OVERRIDE	B+A1
RUN	B+A1 L+A2
START	B+S+A1

**WIRING INSULATED CLIPS**  
NOTE: IF WIRING INSULATED CLIPS WERE REMOVED FOR SERVICING OF UNIT, THEY SHOULD BE REPLACED TO PROPERLY SECURE YOUR WIRING.

03130

**PTO SWITCH**

POSITION	CIRCUIT
OFF	C + G, B + H
ON	C + F, B + E, A + D

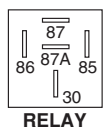

**RELAY**

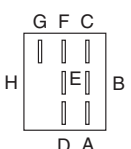

●  
NON-REMOVABLE CONNECTIONS

○  
REMOVABLE CONNECTIONS

TRACTOR -- MODEL NO. CTH150TWIN (96061018100), PRODUCT NO. 960 61 01-81  
ELECTRICAL **32**

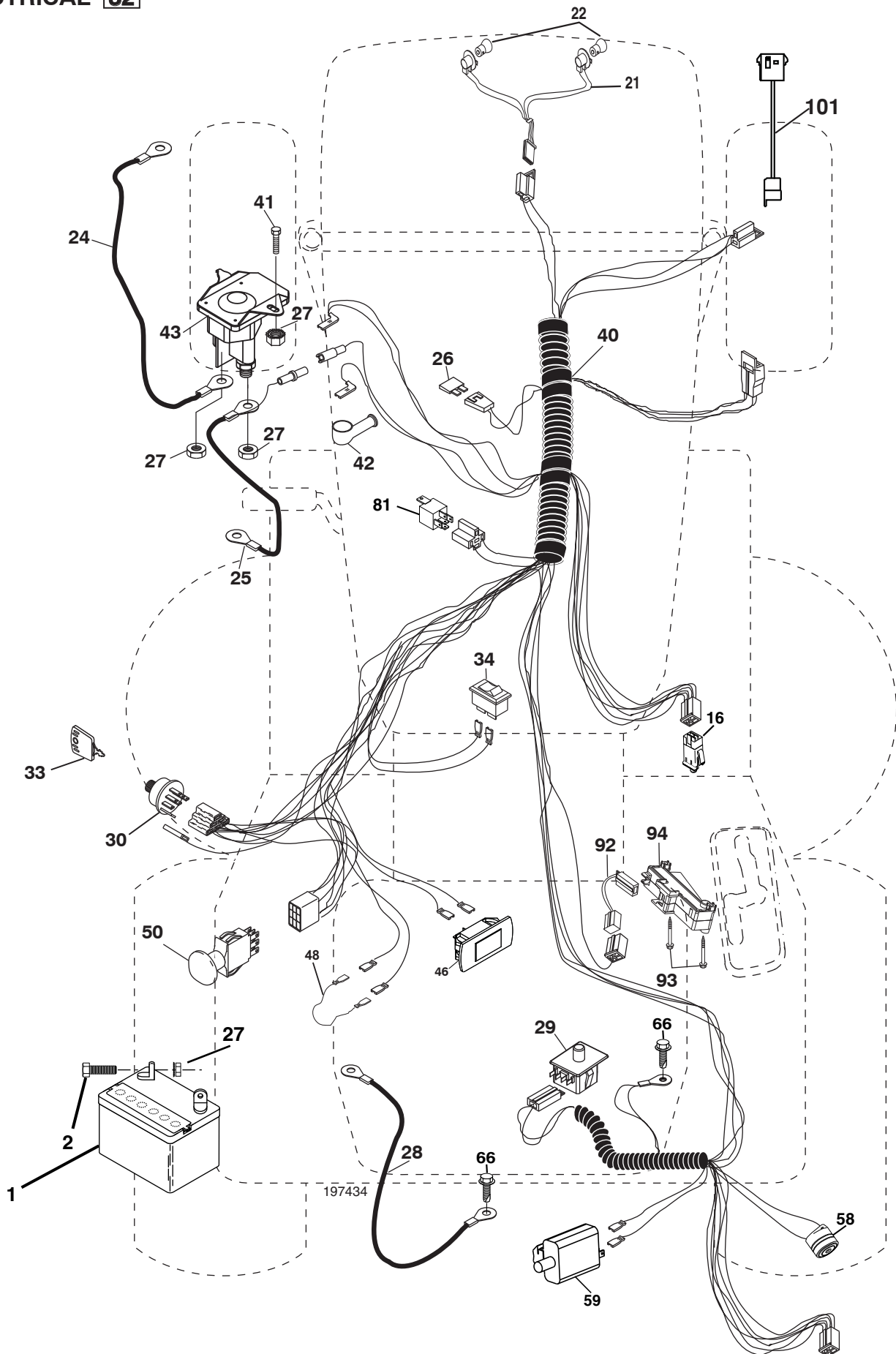

**TRACTOR -- MODEL NO. CTH150TWIN (96061018100), PRODUCT NO. 960 61 01-81  
ELECTRICAL 32**

<b>KEY NO.</b>	<b>PART NO.</b>	<b>DESCRIPTION</b>
1	532 14 49-27	Battery
2	874 76 04-12	Bolt Hex Hd 1/4-20 unc x 3/4
16	532 17 61-38	Switch Interlock
21	532 17 56-88	Harness Asm Light W/4152J
22	532 00 41-52	Bulb Light #1156
24	532 12 47-80	Cable Starter 6 Ga. 11" Red
25	532 16 59-87	Cable Battery CRD 56" Red
26	532 17 51-58	Fuse 20 Amp
27	873 51 04-00	Nut Keps Hex 1/4-20 unc
28	532 12 77-25	Cable Ground 6 Ga. 18" Black
29	532 19 27-49	Switch Seat
30	532 19 33-50	Switch Ignition
33	532 14 04-01	Key Ign
34	532 11 07-12	Switch Light
40	532 19 74-39	Harness Ign
41	871 11 04-08	Bolt Flk Fin Hex 1/4-20 unc x 1/2
42	532 13 15-63	Cover Terminal Red
43	532 19 25-07	Solenoid
46	532 40 17-63	Gauge Hourmeter
48	532 14 08-44	Adapter Ammeter Rectangular
50	532 17 46-51	Switch PTO
58	532 16 94-19	Buzzer CRD
59	532 18 03-79	Switch FBI CRD
66	817 49 06-08	Screw Thdrol 3/8-16 x 1/2 Ty-Tt
81	532 10 97-48	Relay Asm
92	532 19 66-15	Harness Pigtail
93	532 19 25-40	Screw Plastite 10-14 x 2.0
94	532 19 18-34	Module Reverse
101	532 19 83-17	Pigtail

**NOTE:** All component dimensions given in U.S. inches.  
1 inch = 25.4 mm.

**TRACTOR -- MODEL NO. CTH150TWIN (96061018100), PRODUCT NO. 960 61 01-81**  
**CHASSIS AND ENCLOSURES 39**

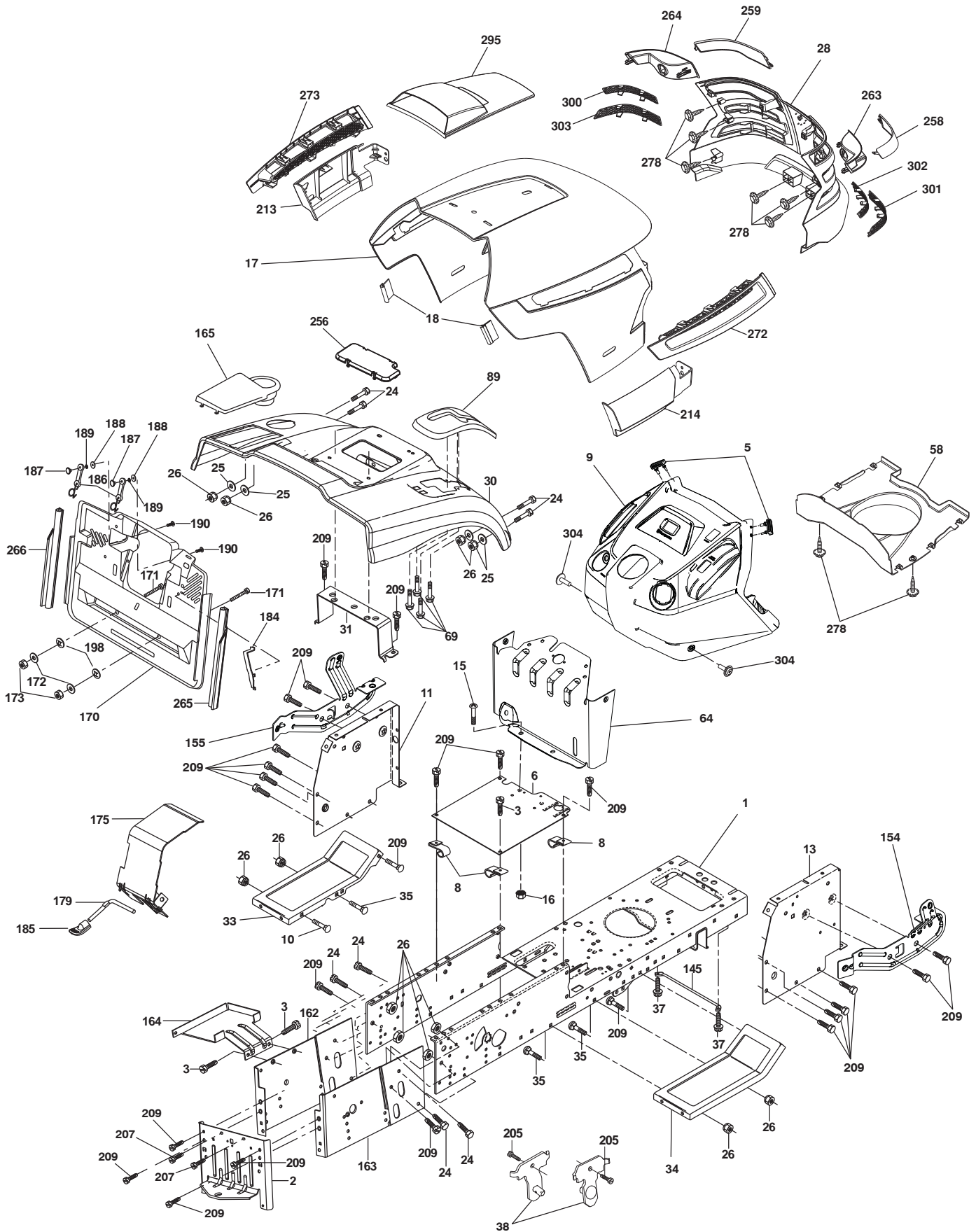



**TRACTOR -- MODEL NO. CTH150TWIN (96061018100), PRODUCT NO. 960 61 01-81  
CHASSIS AND ENCLOSURES 39**

KEY NO.	PART NO.	DESCRIPTION	KEY NO.	PART NO.	DESCRIPTION
1	532 17 46-20	Chassis	172	819 13 20-16	Washer 13/32 x 1-1/4 x 16 Ga.
2	532 18 03-84	Drawbar	173	873 51 06-00	Nut, Keps Hex 3/8-16 unc
3	817 06 06-12	Screw 3/8-16 x 3/4	175	532 18 82-03	Guard Trap
5	532 40 75-90	Bumper Dash	179	532 18 82-02	Rod Pivot FBI CRD
6	532 18 44-19	Saddle	184	532 17 46-62	Bracket Actuator Bagger CRD
8	532 12 64-71	Clip Insulator 13/32 Mtg. Hole	185	532 18 11-01	Knob Rod Brake Parking
9	532 40 89-11	Dash Upper	186	532 16 07-93	Latch Asm Mulch/Bagger
10	872 14 06-08	Bolt, Carriage 3/8-16 x 3/4	187	532 12 50-04	Nut Weld
11	532 16 72-03	Panel, Dash, L.H.	188	819 06 12-16	Washer #10
13	<b>532 17 82-98</b>	Panel, Asm. Dash R.H.	189	810 07 10-00	Washer Lock #10
15	874 18 05-12	Screw, Machine, THD 5/16-18 unc x 3/4	190	871 08 10-10	Screw Pan Hd Phillip 10-24 x 5/8
16	873 51 05-00	Nut Keps 5/16-18 unc	198	532 16 89-37	Nut, Push
17	532 41 10-46	Hood	205	817 49 06-08	Screw Thdrol 3/8-16 x 1/2
18	532 40 47-42	Bumper Hood	207	817 67 05-08	Screw Thdrol 5/16-18 x 1/2
24	874 78 06-16	Bolt	209	817 00 06-12	Screw Hex Wsh Thdrol 3/8-16
25	819 13 13-12	Washer 13/32 x 13/16 x 12 Ga.	213	532 40 17-11	Skirt Side LH
26	873 80 06-00	Nut	214	532 40 17-09	Skirt Side RH
28	532 40 86-07	Grille /Lens Asm	256	532 18 13-61	Cover Fender Rack
30	532 19 73-76	Fender	258	532 19 89-06	Lens RH
31	532 16 51-56	Bracket, Fender Support	259	532 19 89-07	Lens LH
33	532 18 10-57	Footrest, L.H.	263	532 19 71-98	Bezel RH
34	532 18 10-58	Footrest, R.H.	264	532 19 71-99	Bezel LH
35	872 11 06-06	Bolt	265	532 18 57-04	Seal RH Side Bagger
37	817 49 05-08	Screw Thdrol 5/16-18 x 1/2 TYT	266	532 18 57-03	Seal LH Side Bagger
38	532 18 17-48	Bracket Asm Pivot Mower Rear	272	532 40 30-48	Vent Hood RH
58	532 19 85-14	Duct Air	273	532 40 30-76	Vent Hood LH
64	532 19 93-95	Dash Lower	278	532 19 16-11	Screw 10 x 3/4 Single Lead-Hex
69	532 14 24-32	Screw Hx Wsh Hi-Lo 1/4-1/2	295	532 40 05-39	Vent Top Hood
89	532 19 73-77	Console Crd Auto Grey	300	532 19 91-31	Insert Top LH
145	532 15 65-24	Rod Pivot Chassis/Hood	301	532 19 91-30	Insert Top RH
154	532 40 86-90	Bracket Mounting Dash RH	302	532 19 91-32	Insert Bottom RH
155	532 40 86-91	Bracket Mounting Dash LH	303	532 19 91-33	Insert Bottom LH
162	532 18 03-82	Bracket Exten Chassis Lh CRD	304	817 06 04-10	Hex Tapping Screw
163	532 18 03-83	Bracket Exten Chassis Rh CRD			
164	532 16 56-05	Support Battery CRD			
165	532 18 11-00	Cover Battery			
170	532 19 94-88	Backplate CRD			
171	872 14 06-20	Bolt Rdhd Sqnk 3/8-16 x 2-1/2 Gr. 5			

**NOTE:** All component dimensions given in U.S. inches.  
1 inch = 25.4 mm.





**TRACTOR -- MODEL NO. CTH150TWIN (96061018100), PRODUCT NO. 960 61 01-81  
DRIVE 40**

KEY NO.	PART NO.	DESCRIPTION	KEY NO.	PART NO.	DESCRIPTION
1	-----	Transaxle Hydro Gear 321-0510	83	819 17 12-16	Washer 17/32 x 3/4 x 16 Ga.
8	532 19 27-06	Rod, Shift Fender Adjust Lt	84	532 17 00-07	Link, Transaxle
9	532 19 81-43	Clutch Ele	95	532 17 00-15	Control Asm Bypass Hydro
10	876 02 04-16	Pin, Cotter 1/8 x 1	96	532 12 47-88	Spring, Retainer 1"
14	810 04 04-00	Washer, Lock Hvy Helical	112	819 09 12-10	Washer 9/32 x 3/4 x 10 Ga.
15	874 49 05-44	Bolt Hex FGHD 5/16-18 x Gr 5	120	873 90 06-00	Nut Lock Flg. 3/8-16 unc
16	873 80 05-00	Nut, Lock Hex w/Ins 5/16-18 unc	150	532 16 58-50	Bushing, Bellcrank Grnd Dr
17	810 04 07-00	Washer Lock Hvy Hlcl 7/16	151	819 13 32-10	Washer 13/32 x 2 x 10 Ga.
19	873 80 06-00	Nut Lock Hex w/Insert 3/8-16 unc	156	532 16 60-02	Washer Srrted 5/16 ID x 1.125
20	532 17 39-37	Bolt, Hex 7/16-20 x 4	158	532 16 55-89	Bracket Shift Mount
21	532 12 12-74	Knob Deluxe	159	532 18 39-00	Hub Tapered Flange Shift Lt
22	532 17 56-07	Rod, Brake	161	872 14 04-06	Bolt Rdhd Sqnk 1/4-20 x 3/4 Gr 5
24	873 35 06-00	Nut	162	873 68 04-00	Nut Crownlock 1/4-20 unc
25	532 19 20-36	Spring, Rod, Brake	163	874 78 04-16	Bolt Hex Fin 1/4-20 unc x 1 Gr 5
27	876 02 04-12	Pin, Cotter 1/8 x 3/4	165	532 16 56-23	Bracket Pivot Lever
28	532 17 57-65	Rod, Parking Brake	166	817 49 05-10	Screw 5/16-18 x 5/8
29	532 12 42-36	Cap, Parking Brake	167	532 16 55-88	Bracket Support Shift CRD
30	532 16 95-92	Bracket, Mfg. Transaxle	168	532 16 54-92	Bolt Shoulder 5/16-18 x .561
34	532 17 55-78	Shaft, Asm Pedal Foot CRD	169	532 16 55-80	Plate Fastening Lt
35	532 12 01-83	Bearing, Nylon	171	817 49 06-08	Screw Thdrol 3/8-16 x 1/2 Ty-Tt
36	819 21 16-16	Washer 21/32 x 1 x 16 Ga.	172	532 17 02-71	Shaft Asm Shifter Frt CRD
37	532 12 49-63	Pin, Roll 3/16 x 1"	177	532 16 59-32	Keeper Flat Idler 3.06" CRD
38	532 16 59-36	Pulley Flat Composite 3.06"	181	532 18 02-11	Bracket Idler Ground Drive CRD
39	874 76 06-44	Bolt Fin Hex 3/8-16 unc x 2-3/4	182	532 18 26-82	Keeper Belt 2.5" Od V-Idler CRD
40	532 12 49-65	Spacer, Split 395 x 59 Bzp	183	532 19 95-32	Pulley V-Idler CRD
42	819 13 13-12	Washer 13/32 x 13/16 x 12 Ga.	185	532 17 00-08	Link Shift
43	819 11 10-12	Washer 11/32 x 5/8 x 12 Ga.	186	532 16 56-14	Hub Tapered Round CRD
47	532 12 77-83	Pulley, Idler, V Groove Plasic	187	817 58 05-20	Screw Thdrol 5/16-18 x 1.25
48	532 15 44-07	Bellcrank Clutch Grnd Drv	197	532 16 96-13	Nyliner Snap-In 5/8
49	532 12 32-05	Retainer, Belt Style Spring	199	532 16 96-12	Bolt Shoulder 5/16-18 unc
50	872 11 06-12	Bolt Carr. Sh. 3/8-16 x 1-1/2 Gr 5	200	872 14 05-08	Bolt RDHD SQNK 5/16-18 x 1
51	873 68 06-00	Nut, Crownlock 3/8-16 unc	207	532 16 98-45	Washer Nylon Rear
52	873 6805-00	Nut Crownlock 5/16-18	214	532 17 56-09	Shaft Asm. Brake
53	532 19 96-52	Link, Clutch 7.66	215	532 17 56-52	Rod Brake Hydro
55	532 10 57-09	Spring, Return, Clutch	243	532 19 07-36	Bracket Anti Rotation
56	817 06 06-20	Screw 3/8-16 x 1-1/4	252	819 13 16-16	Washer 13/32 x 1 x 16 Ga.
57	532 17 01-40	V-Belt Kev 112" 0650 CRD	254	817 00 06-16	Screw 3/8-16 x 1
62	532 12 48-72	Cover, Pedal	255	532 17 56-08	Brace Shaft Brake Mtg.
63	532 18 03-97	Pulley, Engine	258	532 17 80-62	Clip Retainer
65	532 12 61-97	Washer	259	532 18 02-12	Bracket Pulley
66	532 15 47-78	Keeper, Belt Engine F-Proof	260	532 19 76-07	Bracket Idler Chassis
71	532 16 91-83	Strap, Torque, Lh	261	532 13 14-94	Pulley Idler Flat
73	532 16 91-82	Strap, Torque, Rh	262	872 11 06-22	Bolt Rdhd 3/8-16 unc x 2-3/4 Gr 5
74	532 13 70-57	Spacer, Split	263	817 00 06-12	Screw Hx Wsh Thdrol 3/8-16 x 3/4
75	532 12 17-49	Washer 25/32 x 1-1/4 x 16 Ga.	266	532 18 20-61	Shield Idler
76	812 00 00-01	Ring, E	279	872 11 06-16	Bolt Rdhd Sqnk 3/8-16 unc x 2
77	532 12 35-83	Key, Square	292	532 40 02-71	Spacer Noram
78	532 12 17-48	Washer 25/32 x 1-5/8 x 16 Ga.	295	532 17 91-14	Pulley Idler Composite
81	532 17 00-06	Asm, Shaft			
82	532 16 57-11	Spring, Torsion			

**NOTE:** All component dimensions given in U.S. inches  
1 inch = 25.4 mm

**TRACTOR -- MODEL NO. CTH150TWIN (96061018100), PRODUCT NO. 960 61 01-81  
ENGINE 24**

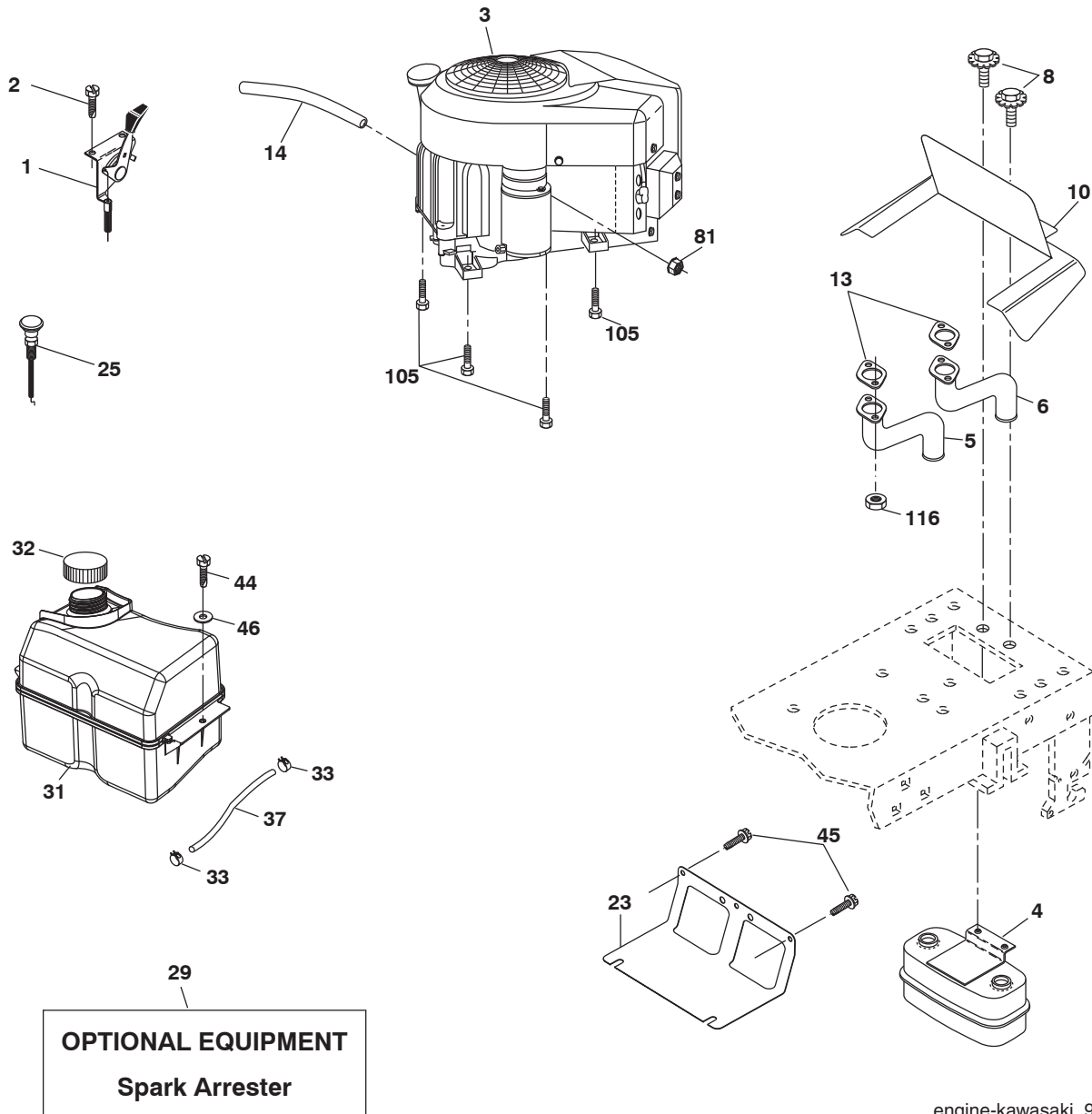

engine-kawasaki\_9

KEY NO.	PART NO.	DESCRIPTION
1	532 17 83-85	Control Throttle
2	532 19 16-11	Screw 10 x 3/4 Single Lead Hex
3	---	Engine Kawasaki FH430V-BS11
--	---	Gasket Muffler
4	532 14 97-23	Muffler Twin Lo-Tone
5	532 18 14-44	Pipe Exhaust Lh
6	532 18 14-42	Pipe Exhaust Rh
8	532 17 18-77	Bolt 5/16-18 unc x 3/4 w/Sems
10	532 14 66-29	Shield Heat Muffler
14	532 14 84-56	Tube Drain Oil Easy
23	532 16 98-37	Shield Brn/Dbr Guard
25	532 18 95-41	Choke Control
29	532 13 71-80	Kit Spark Arrestor
31	532 18 55-34	Tank Fuel

KEY NO.	PART NO.	DESCRIPTION
32	532 19 77-25	Cap Asm Fuel Top
33	532 12 34-87	Clamp Hose Blk
37	532 13 70-40	Line Fuel
44	817 67 04-12	Screw Hexwsh Thdrol 1/4-20 x 3/4
45	817 00 06-12	Screw Hexwsh Thdrol 3/8-16 x 3/4
46	819 09 14-16	Washer 9/32 x 7/8 x 16 Ga.
81	873 51 04-00	Nut Keps Hex 1/4-20 unc
105	817 12 06-16	Screw 3/8-16 x 1
116	532 18 43-62	Nut Hex Flange Toplock M8-1.25

**NOTE:** All component dimensions given in U.S. inches  
1 inch = 25.4 mm

**TRACTOR -- MODEL NO. CTH150TWIN (96061018100), PRODUCT NO. 960 61 01-81  
SEAT ASSEMBLY 42**

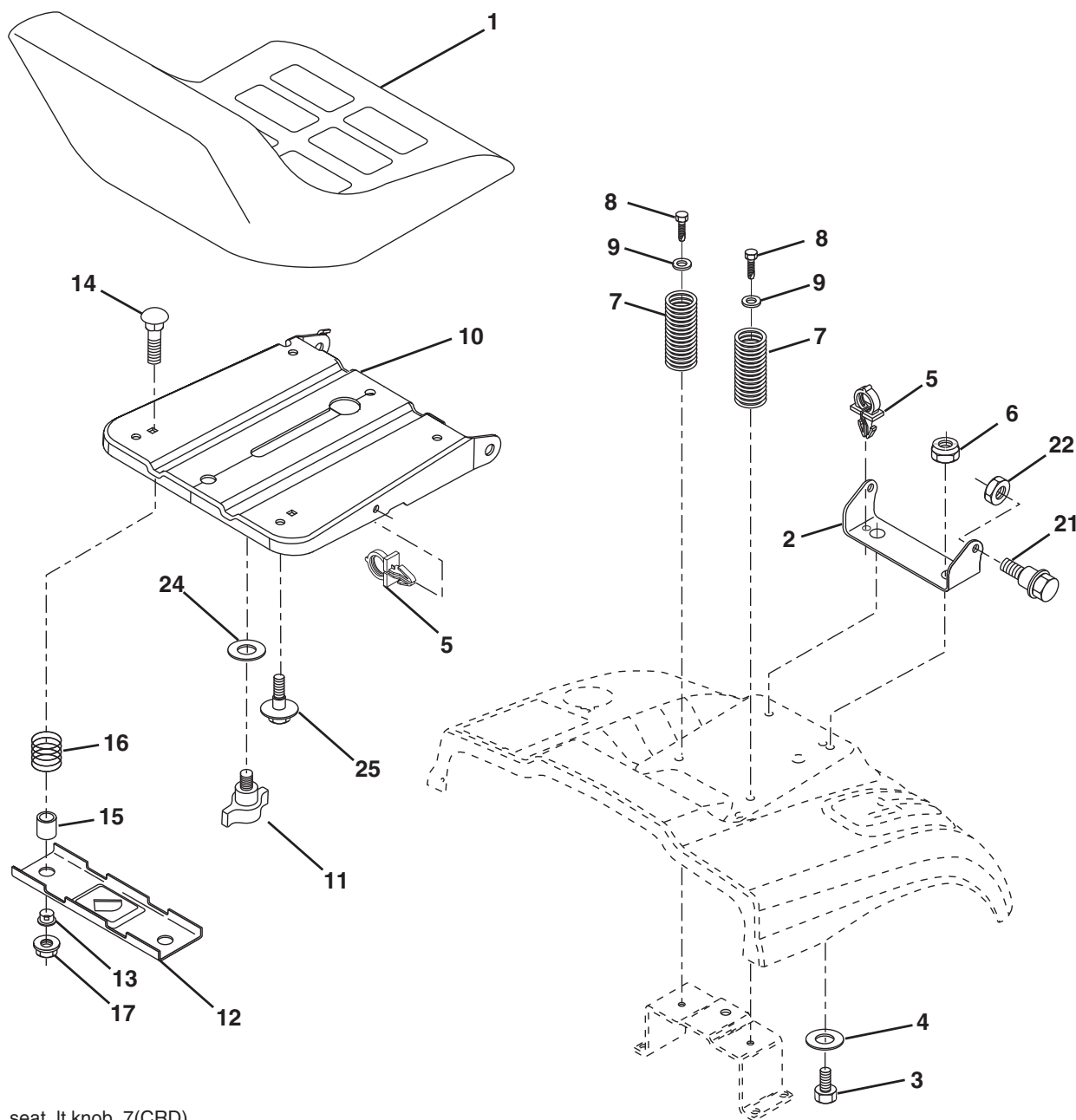

seat\_lt.knob\_7(CRD)

KEY NO.	PART NO.	DESCRIPTION	KEY NO.	PART NO.	DESCRIPTION
1	532 18 87-15	Seat	12	532 17 46-48	Bracket Pnt Mounting Switch
2	532 14 05-51	Bracket Pivot	13	532 12 12-48	Bushing Snap Blk Nyl 50 Id
3	871 11 06-16	Bolt Fin Hex 3/8-16 x 1	14	872 05 04-12	Bolt Rdhd Sht Nk 1/4-20 x 1-1/2
4	819 13 16-10	Washer flat 13/32 x 1 x 10 Ga.	15	532 12 12-49	Spacer Split 28 x 88 Zinc
5	532 14 50-06	Clip Push In Hinged	16	532 12 37-40	Spring Cprsn
6	873 80 06-00	Nut Lock Hex 3/8-16 unc	17	532 12 39-76	Nut Lock 1/4 Lge Flg Gr 5 Zinc
7	532 12 41-81	Spring Seat Cprsn 2 250 Blk Zi	21	532 17 18-52	Bolt Shoulder 5/16-18 unc-2A
8	817 00 06-16	Screw 3/8-16 x 1-1/2	22	873 80 05-00	Nut Hex Lock w/Ins 5/16-18
9	819 13 16-14	Washer 13/32 x 1 x 14 Ga	24	819 17 19-12	Washer 17/32 x 1-3/16 x 12 Ga.
10	532 19 55-30	Pan Seat	25	532 12 70-18	Bolt Shoulder 5/16-18 x .62
11	532 16 63-69	Knob Seat Adj. Wingnut			

**NOTE:** All component dimensions given in U.S. inches.  
1 inch = 25.4 mm

**TRACTOR -- MODEL NO. CTH150TWIN (96061018100), PRODUCT NO. 960 61 01-81**  
**STEERING ASSEMBLY 41**

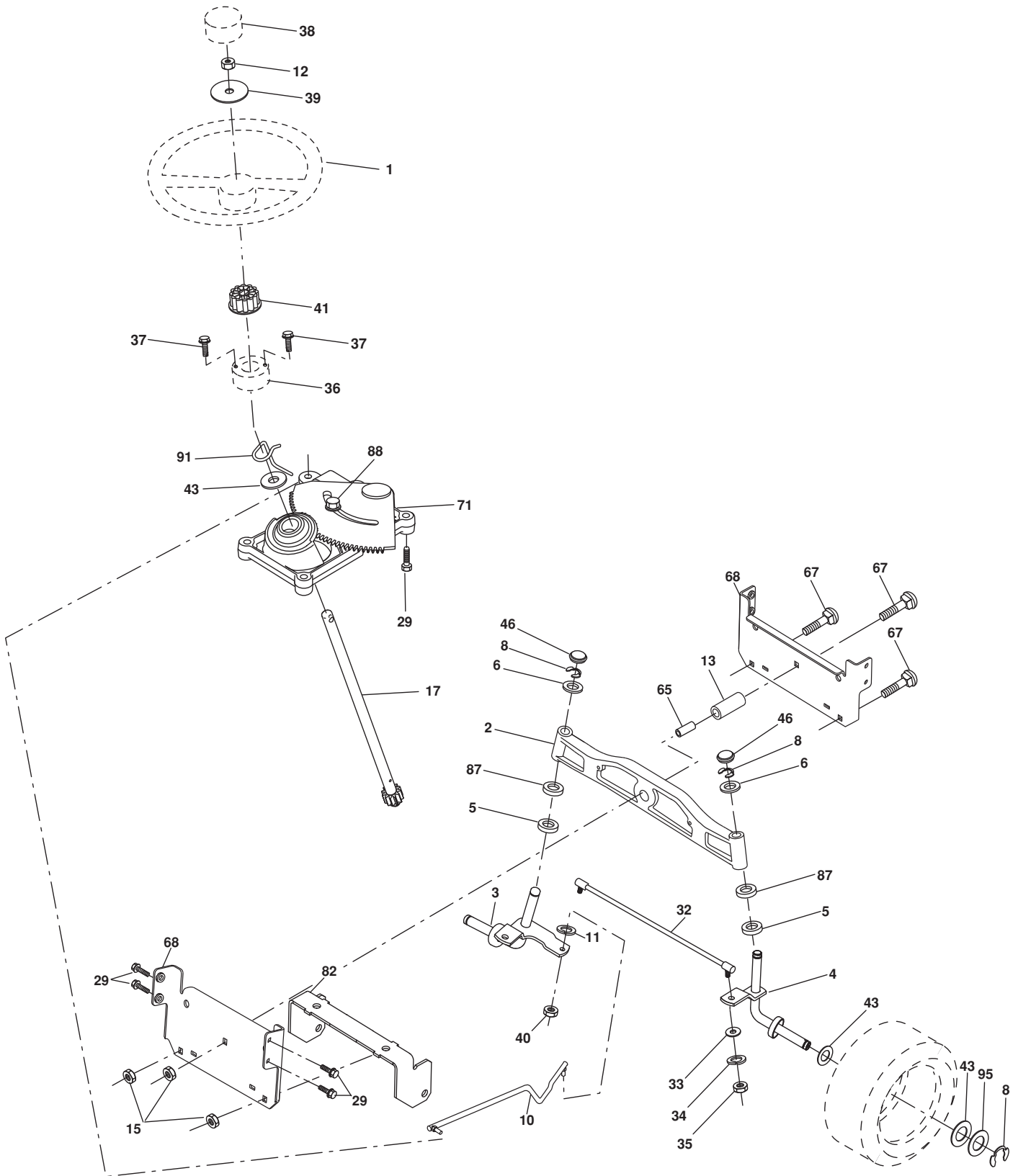

steering\_TEX\_prem\_16

**TRACTOR -- MODEL NO. CTH150TWIN (96061018100), PRODUCT NO. 960 61 01-81  
STEERING ASSEMBLY 41**

KEY NO.	PART NO.	DESCRIPTION
1	532 19 36-51	Steering Wheel
2	532 18 47-06	Front Axle Assembly
3	532 16 98-40	Spindle Assembly, L.H.
4	532 16 98-39	Spindle Assembly, R.H.
5	532 12 49-31	Bearing, Race, Thrust, Hardened
6	532 12 17-48	Washer 25/32 x 1-5/8 x 16 Ga.
8	812 00 00-29	Ring, Klip
10	532 17 51-21	Link, Drag
11	810 04 06-00	Washer, Lock
12	873 94 08-00	Nut Hex Jam Toplock 1/2-20 unf
13	532 13 65-18	Spacer Axle
15	532 14 52-12	Nut Hex Flange Lock
17	532 17 78-83	Shaft Assembly, Steering
29	817 00 06-12	Screw 3/8-16 x 3/4
32	532 17 18-88	Rod, Tie
33	819 11 12-16	Washer 11/32 x 3/4 x 16 Ga.
34	810 04 05-00	Washer Lock Hvy Hlcl Spr 5/16
35	873 54 05-00	Crownlock Nut 5/16-24 unf
36	532 15 51-05	Bushing, Steering
37	532 15 29-27	Screw TT #10-32 x 5 x 3/8 Flange
38	532 19 36-51	Cap Wheel Steer
39	819 18 38-12	Washer 9/16 ID x 2-3/8 OD 12 Ga.
40	873 54 06-00	Nut Crownlock 3/8-24
41	532 18 67-37	Adaptor, Steering Wheel
43	532 12 17-49	Washer 25/32 x 1-1/4 x 16 Ga.
46	532 12 12-32	Cap, Spindle
65	532 16 03-67	Spacer Axle
67	872 11 06-18	Bolt Rdhd Sq 3/8-16 x 2-1/4
68	532 16 98-27	Brace Axle
71	532 17 51-46	Steering Asm.
82	532 19 99-78	Bracket Susp. Chassis Front
87	532 17 39-66	Washer Flat .781 x 1-1/2 x .14
88	532 17 51-18	Bolt Shoulder 7/16-20 unc
91	532 17 55-53	Clip Steering
95	532 18 89-67	Washer

**NOTE:** All component dimensions given in U.S. inches.  
1 inch = 25.4 mm.



TRACTOR -- MODEL NO. CTH150TWIN (96061018100), PRODUCT NO. 960 61 01-81  
MOWER DECK 44

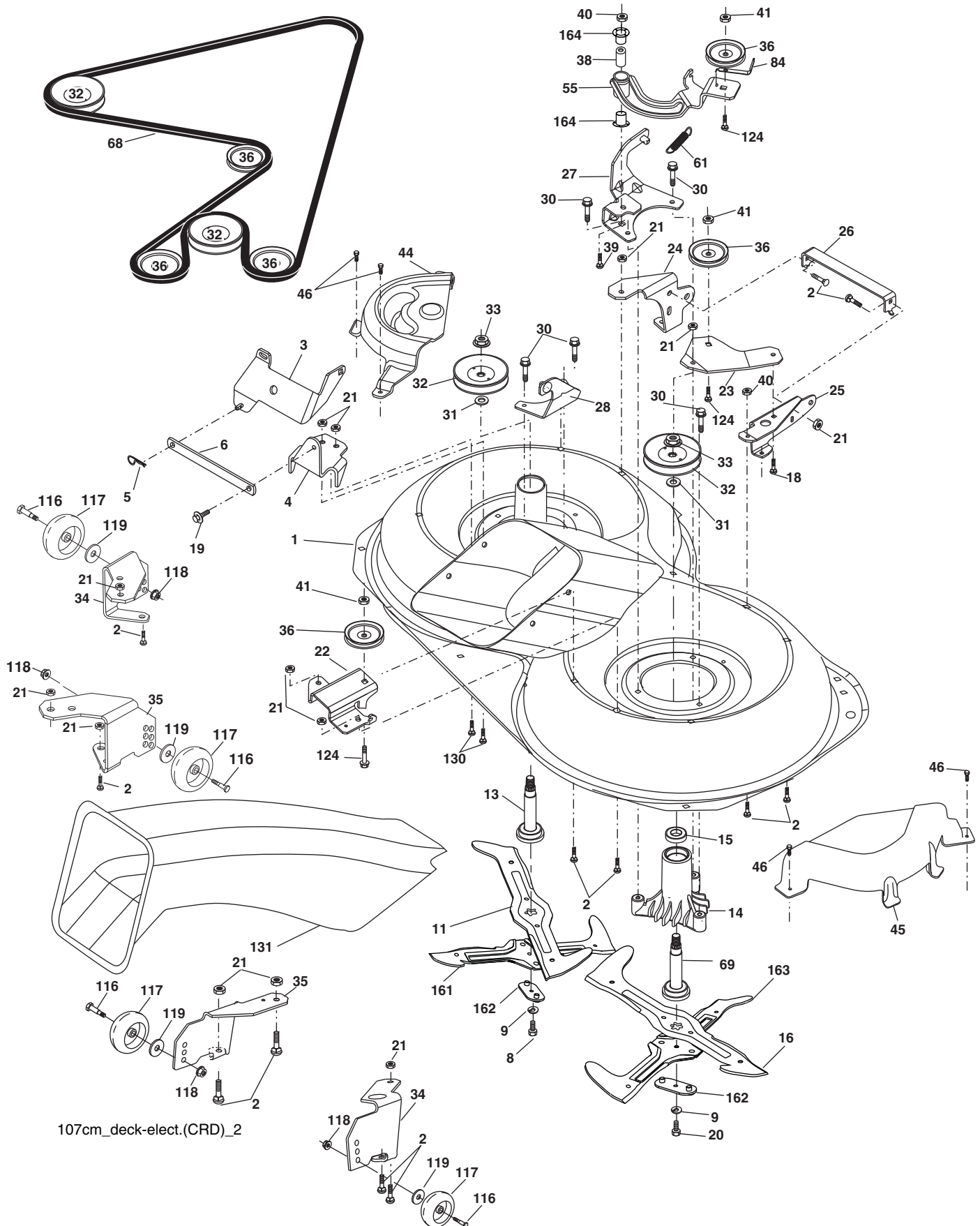

107cm\_deck-elect.(CRD)\_2



**TRACTOR -- MODEL NO. CTH150TWIN (96061018100), PRODUCT NO. 960 61 01-81  
MOWER DECK 44**

KEY NO.	PART NO.	DESCRIPTION	KEY NO.	PART NO.	DESCRIPTION
1	532 16 91-60	Housing Asm. Mower 107 CRD	35	532 40 01-04	Bracket Gauge Wheel RF/LR
2	872 14 05-06	Bolt Rdhd Sqnk 5/16-18 unc x 3/4	36	532 14 67-63	Pulley Idler V-Groove Dim 4.25
3	532 16 55-69	Bracket Asm. S-Bar Chass 92 CRD	38	532 16 98-51	Spacer Hub Arm Idler 107 CRD
4	532 16 91-67	Bracket Bar Sway Deck 107 CRD	39	872 11 06-22	Bolt Rdhd 3/8-16 unc x 2-3/4 Gr. 5
5	532 12 46-70	Retainer Spring	40	873 68 06-00	Nut Crownlock 3/8-16 unc
6	532 16 55-57	Bar Sway CRD	41	873 90 06-00	Nut Flangelock 3/8-16 unc
8	532 18 17-12	Bolt 3/8-24 x 1.25 Gr. 8 Patched	44	532 17 55-38	Cover Mandrel Lh 107 CRD
9	810 03 06-00	Washer Lock Hvy 3/8 Unplated	45	532 17 55-39	Cover Mandrel Rh 107 CRD
11	532 18 05-83	Blade 3-1 Lh 107 CRD	46	532 13 77-29	Screw Thd Roll 1/4-20 x 5/8
13	532 13 76-45	Shaft Asm. W/Lower Bearing	55	532 16 98-49	Arm Idler 107 CRD
14	532 12 87-74	Housing Mandrel Vented (Machd)	61	532 19 94-87	Spring Tension Belt
15	532 11 04-85	Bearing Ball Mandrel	68	532 40 20-09	Hex-Belt 107 Mower
16	532 18 05-84	Blade 3-1 Rh 107 CRD	69	532 16 54-82	Shaft Asm W/Lwr Brg Rh Thd CRD
18	872 11 06-06	Bolt RdHd Sqnk 3/8-16 x 3/4	84	532 15 60-85	Keeper Belt Idler
19	532 13 28-27	Bolt Shoulder 5/16-18 Thd Form	116	532 19 34-06	Bolt Shoulder
20	532 18 17-13	Bolt 3/8-24 x 1.25 Gr.8 Ptch Lhthd	117	532 17 48-73	Wheel Gage Donut Wide
21	873 68 05-00	Nut Crown Lock 5/16-18	118	873 93 06-00	Nut Centerlock 3/8-16 unc
22	532 16 91-65	Bracket Idler Sprt RR 107 CRD	119	819 13 20-12	Washer 13/32 x 1-1/4 x 12 Ga.
23	532 16 91-66	Bracket Idler Sprt RF 107 CRD	124	872 11 06-12	Bolt Carr Sh 3/8-16 x 1-1/2 Gr. 5
24	532 16 91-70	Bracket Suspension LF 107 CRD	130	872 11 05-06	Bolt Rdhd sqnk 5/16-18 unc x 3/4
25	532 40 01-05	Bracket Suspension RF 107 CRD	131	532 16 56-61	Chute Bagger CRD 92cm
26	532 40 01-10	Brace Support Susp Frt CRD	161	532 18 04-24	Blade Cross LH 107
27	532 16 91-72	Bracket Asm. Susp RR 107 CRD	162	532 18 08-78	Adapter Weldment Blade 107
28	532 16 91-68	Bracket Asm. Susp LR 107 CRD	163	532 18 04-25	Blade Cross RH 107
30	532 17 39-84	Screw Thd Rolling Hex	164	532 12 49-37	Bearing Col. Strg.
31	532 18 76-90	Washer Spacer	--	532 18 18-57	Mandrel Asm Service
32	532 19 81-45	Mandrel Pulleys	--	532 18 18-58	Mandrel Asm CRD Lh Threads SVC
33	532 40 02-34	Nut Flg Top Lock	--	532 40 03-25	Replacement Mower Complete
34	532 40 01-03	Bracket Gauge Wheel LF/RR			

**NOTE:** All component dimensions given in U.S. inches  
1 inch = 25.4 mm

TRACTOR -- MODEL NO. CTH150TWIN (96061018100), PRODUCT NO. 960 61 01-81  
 MOWER LIFT **45**

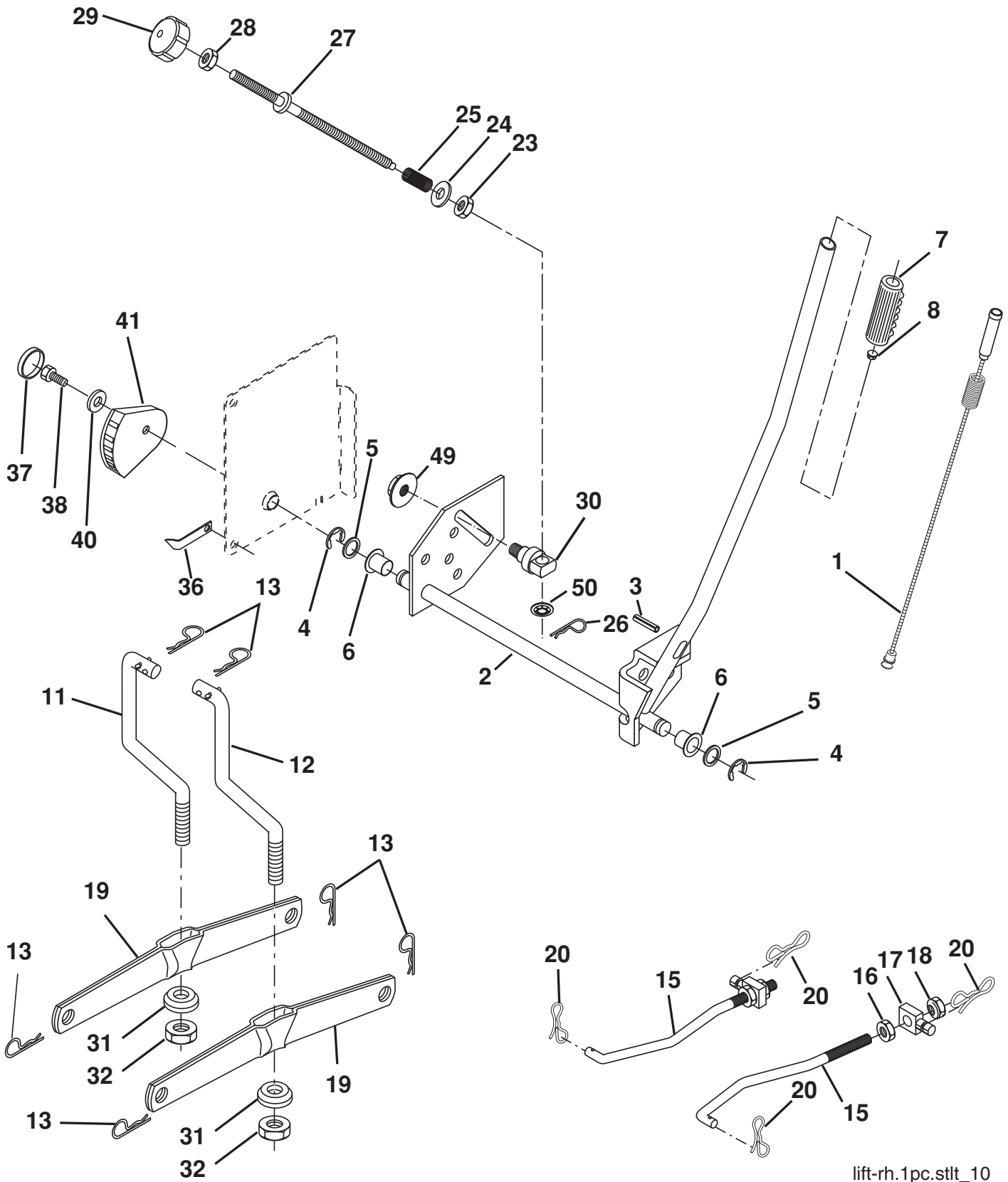

lift-rh.1pc.stlt\_10

**TRACTOR -- MODEL NO. CTH150TWIN (96061018100), PRODUCT NO. 960 61 01-81  
MOWER LIFT 45**

<b>KEY NO.</b>	<b>PART NO.</b>	<b>DESCRIPTION</b>
1	532 19 84-17	Washer Asm Inner Spring W/Plunger
2	532 19 80-70	Shaft Asm. Lift
3	532 18 88-22	Pin Groove
4	812 00 00-02	E Ring #5133-62
5	819 21 16-21	Washer 21/32 x 1 x 21 Ga.
6	532 12 01-83	Bearing Nylon
7	532 12 56-31	Grip Handle Fluted
8	532 12 23-65	Button Plunger
11	532 16 58-29	Link Asm Lift L.H.
12	532 16 58-31	Link Asm Lift R.H.
13	532 12 46-70	Retainer Spring
15	532 17 32-88	Link Front
16	873 35 08-00	Nut Jam Hex 1/2-13 unc
17	532 17 56-89	Trunnion Blk Zinc
18	873 80 08-00	Nut Lock W/Wsh 1/2-13 unc
19	532 13 98-68	Arm Suspension Mower
20	532 19 42-09	Pin Cotter 7/16 Bow Tie Lock
23	532 11 08-07	Nut Special
24	819 13 10-16	Washer 13/32 x 5/8 x 16 Ga.
25	532 16 40-24	Spring
26	532 16 94-84	Retainer Clip
27	532 16 45-43	Rod Adj Lift
28	873 35 06-00	Nut Hex Jam 3/8-16 unc
29	532 13 80-57	Knob Inf 3/8-16 unc Blk w/sym
30	532 15 02-33	Trunnion Infin Height
31	532 16 98-65	Bearing, Pvt. Lift.
32	873 54 06-00	Nut Crownlock 3/8-24
36	532 15 50-97	Pointer Height Indicator
37	532 12 39-35	Plug Hole Blk 1.485/1.515 Dia
38	817 06 05-16	Screw 5/16-18 x 1
40	819 11 24-10	Washer 11/32 x 1-1/2 x 10 Ga.
41	532 12 39-34	Scale Ind Height Blk
49	532 14 52-12	Nut hex Flange Lock
50	532 11 04-52	Nut Push Phos & Oil

**NOTE:** All component dimensions given in U.S. inches  
1 inch = 25.4 mm

TRACTOR -- MODEL NO. CTH150TWIN (96061018100), PRODUCT NO. 960 61 01-81  
BAGGER **46**

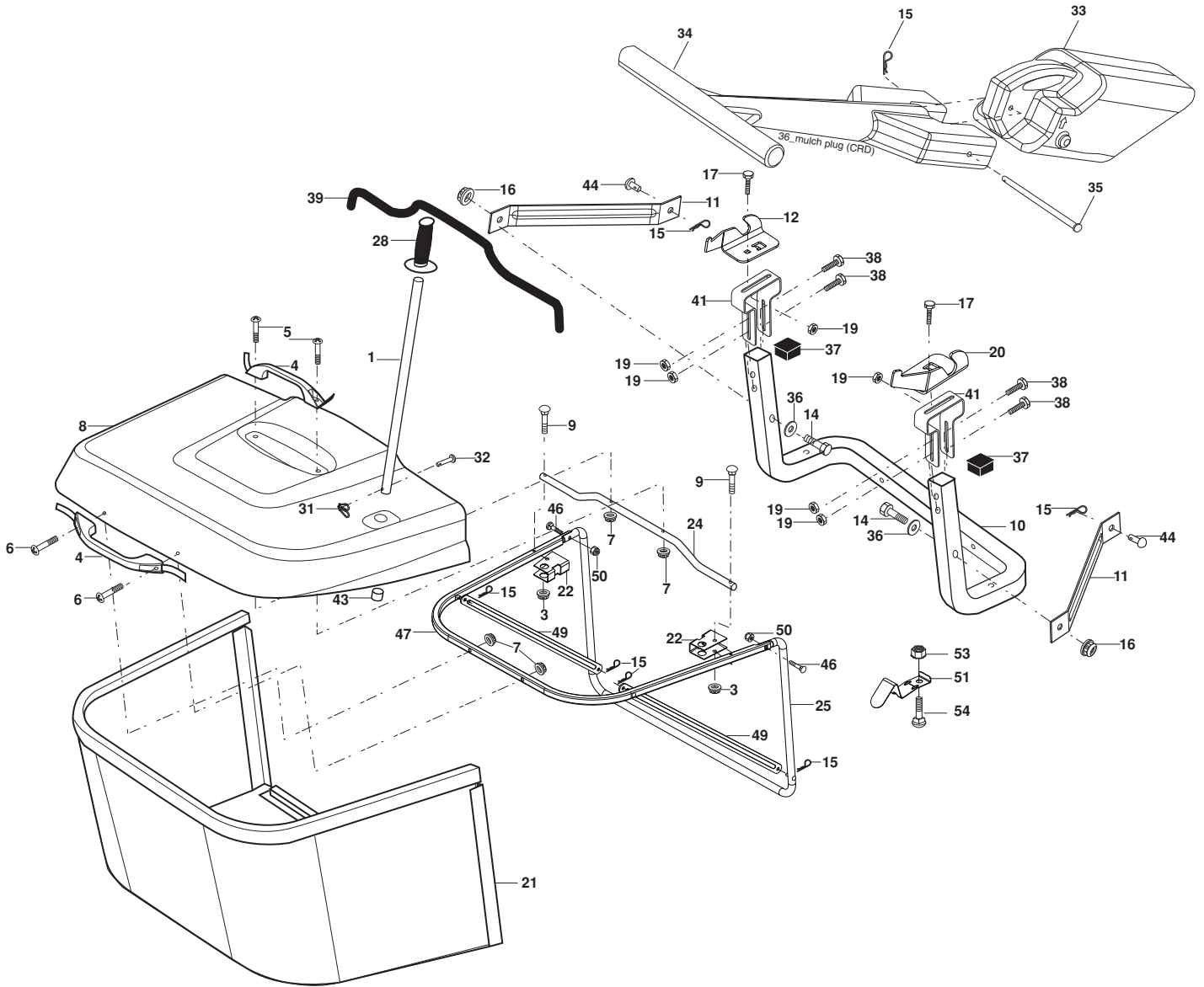

Bagger Asy (CRD)\_12

**TRACTOR -- MODEL NO. CTH150TWIN (96061018100), PRODUCT NO. 960 61 01-81  
BAGGER 46**

<b>KEY NO.</b>	<b>PART NO.</b>	<b>DESCRIPTION</b>
1	532 16 52-49	Tube Handle Bagger CRD
3	532 12 39-76	Nut Lock 1/4 Lge Flg Gr. 5 Zinc
4	532 16 99-16	Handle Bagger w/Lvrs Blk CRD
5	874 98 10-24	Screw Pan Head #10-24 x 1.50 Blk
6	874 98 10-32	Screw Pan Hd
7	873 40 10-00	Nut Wiz Lock Hex Serr/Hd 10-24
8	532 18 10-95	Cover Bagger
9	872 14 04-18	Bolt Carriage 1/4-20 x 2.25d x Gr.5
10	532 18 12-82	Tube Support Bagger CRD
11	532 16 57-19	Bracket Support Upper Bag CRD
12	532 18 88-48	Bracket Lh
14	874 52 06-36	Bolt Fin Hex 3/8-16 x 2 x 1/4 Gr. 5
15	532 12 46-70	Retainer Spring
16	873 90 06-00	Nut Lock Flg 3/8-16 unc
17	872 14 05-06	Bolt Rdhd Sht Sqnk 5/16 -18 unc x 3/4
19	873 90 05-00	Nut Lock Hex Flange 5/16-18
20	532 18 88-47	Bracket Horiz Adj Bagger Rh
21	532 40 61-80	Bag Asm CRD
22	532 16 57-81	Bracket Side Bagger CRD
24	532 16 57-83	Tube Pivot Bagger CRD
25	532 19 37-05	Tube Front Bagger CRD
28	532 16 57-87	Grip Handle Black
31	532 16 94-84	Retainer Clip Dia. .290
32	532 12 68-75	Rivet Rd Hd Drilled 3/8 Dia
33	532 16 93-80	Plug Mulcher
34	532 16 55-70	Handle Mulcher
35	532 16 55-72	Pin Mulcher
36	819 13 20-12	Washer 13/32 x 1-1/4 x 12 Ga.
37	532 17 54-01	Plug Support Bagger CRD
38	872 01 05-20	Bolt 5/16-18 x 2-1/2
39	532 18 09-85	Seal Trim
41	532 16 96-83	Bracket Pnt Adj Pvt Bagger CRD
43	532 17 40-83	Plug Tubing End
44	532 19 33-12	Pin Clevis 3/8" x 11/16"
46	872 11 05-10	Bolt Carr. 5/16-18 x 1-1/4 Gr. 5
47	532 19 37-04	Tube Upper Bagger
49	532 19 33-05	Bar Spreader Bagger
50	873 80 05-00	Nut Lock Hex w/insert 5/16-18 unc
51	532 19 99-03	Latch Spring Bagger
53	873 51 04-00	Nut Keps Hex 1/4-20 unc
54	872 14 04-06	Bolt Rdhd Sqnk 1/4-20 x 3/4 Gr. 5

**NOTE:** All component dimensions given in U.S. inches  
1 inch = 25.4 mm

