

Ride Mower

2042 LS (CA)

96043004800

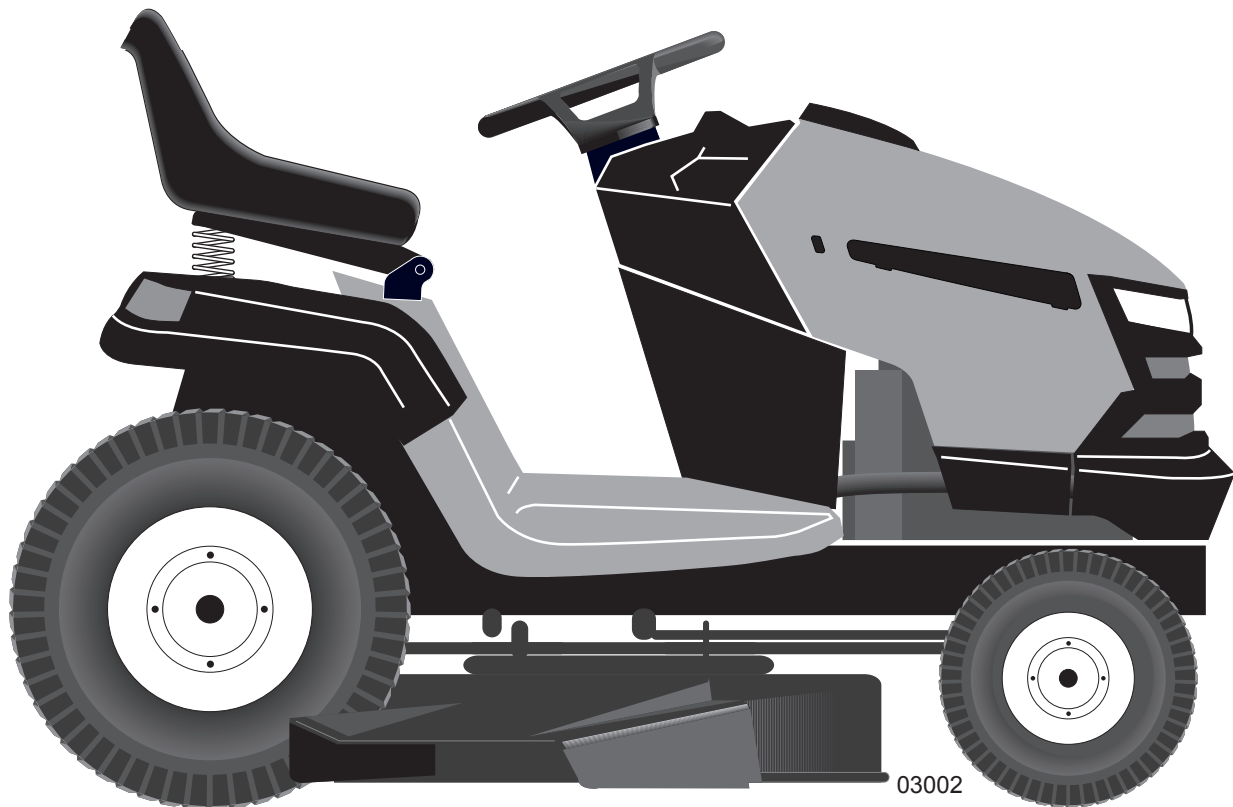

Illustrated Parts List

TRACTOR - - MODEL NUMBER 2042LS (96043004800), PRODUCT NO. 960 43 00-48 SCHEMATIC

SCH12

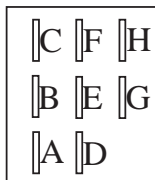
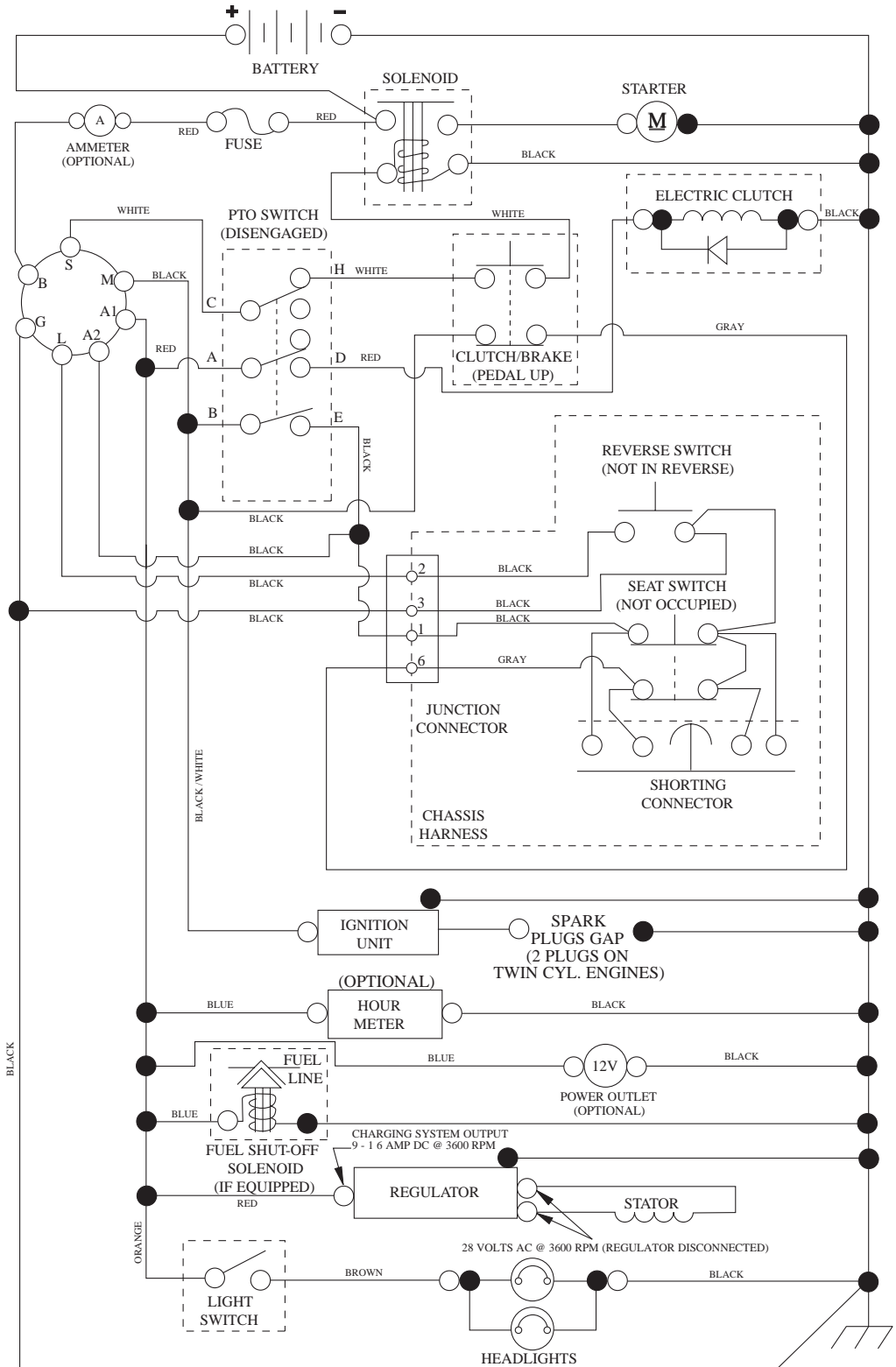

PTO SWITCH (MATING SIDE)

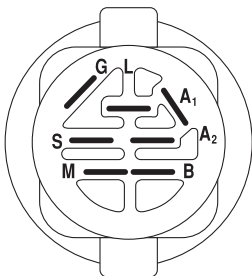

| POSITION | CIRCUIT | "MAKE" |
|--------------|------------|--------|
| OFF | M+G+A1 | |
| RUN/OVERRIDE | B+A1 | |
| RUN | B+A1 | L+A2 |
| START | B + S + A1 | |

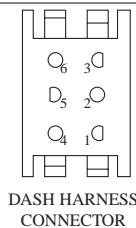

WIRING INSULATED CLIPS
NOTE: IF WIRING INSULATED CLIPS WERE REMOVED FOR SERVICING OF UNIT, THEY SHOULD BE RE-INSTALLED TO PROPERLY SECURE YOUR WIRING.

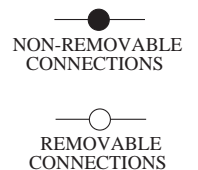

**TRACTOR - - MODEL NUMBER 2042LS (96043004800), PRODUCT NO. 960 43 00-48
ELECTRICAL**

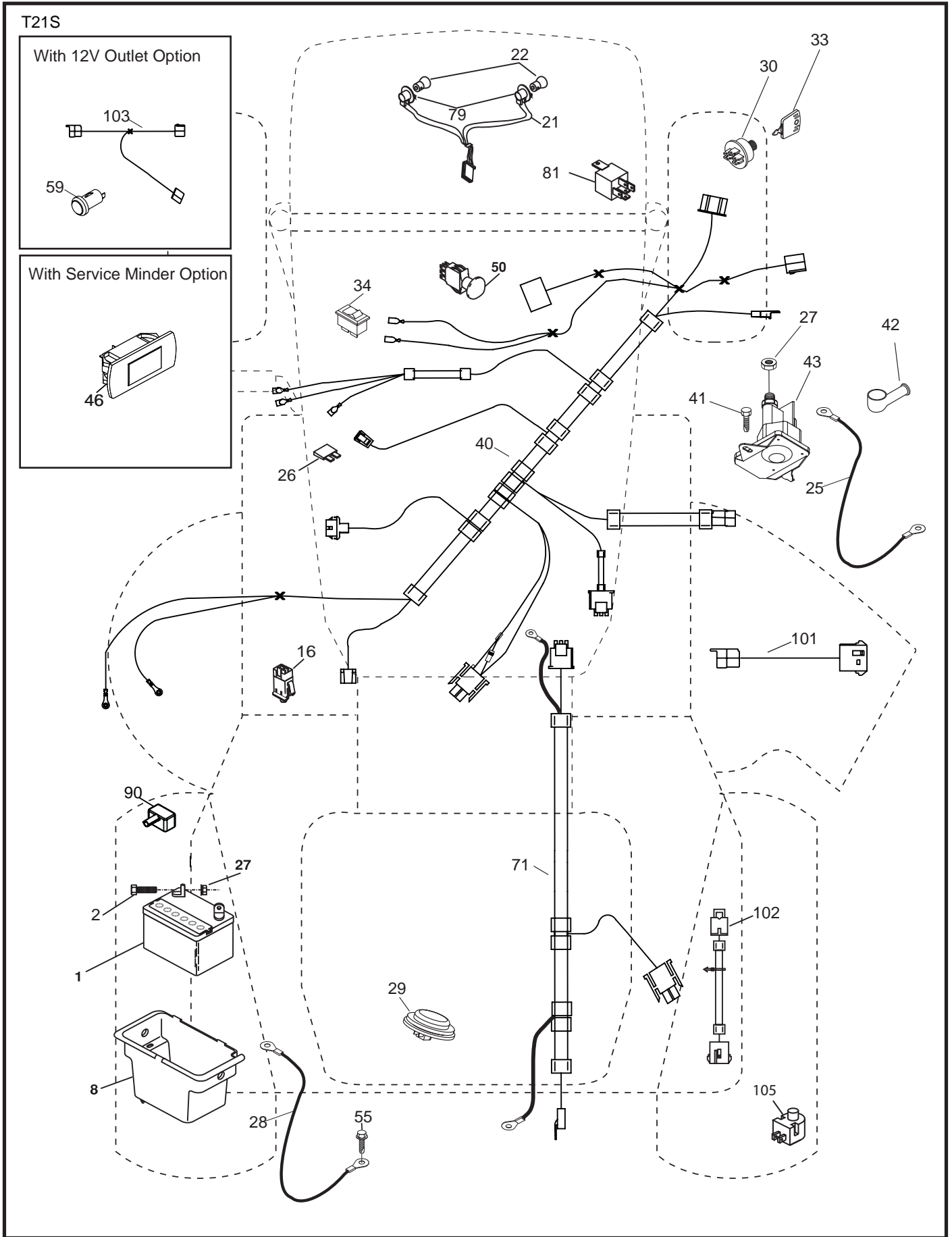

**TRACTOR - - MODEL NUMBER 2042LS (96043004800), PRODUCT NO. 960 43 00-48
ELECTRICAL**

| KEY NO. | PART NO. | DESCRIPTION |
|----------------|-----------------|---------------------------------|
| 1 | 532 16 34-65 | Battery |
| 2 | 874 76 04-12 | Bolt Hex Head 1/4-20 x 3/4 |
| 8 | 532 19 32-28 | Box Battery |
| 16 | 532 17 61-38 | Switch Interlock Push-In |
| 21 | 532 18 37-59 | Harness Socket Light w/4152J |
| 22 | 532 00 41-52 | Bulb Light |
| 25 | 532 41 28-95 | Cable Starter |
| 26 | 532 17 51-58 | Fuse |
| 27 | 873 51 04-00 | Nut Keps Hex 1/4-20 unc |
| 28 | 532 19 88-85 | Cable, Ground |
| 29 | 532 40 15-45 | Switch, Seat |
| 30 | 532 19 33-50 | Switch, Ign |
| 33 | 532 41 19-35 | Key/Chain |
| 34 | 532 11 07-12 | Switch Light/Reset |
| 40 | 532 40 11-04 | Harness Ign. Dash |
| 41 | 817 72 04-08 | Screw Thd Cut 1/4-20 x 1/2 |
| 42 | 532 13 15-63 | Cover, Terminal |
| 43 | 532 19 25-07 | Solenoid |
| 46 | 532 40 17-63 | Gauge Service Reminder Hrmtr |
| 50 | 532 17 46-51 | Switch PTO |
| 55 | 817 06 05-12 | Screw Thdrol 5/16-18 x 3/4 TYTT |
| 59 | 532 40 03-03 | Outlet 12-Volt |
| 71 | 532 40 04-49 | Harness Ign. |
| 79 | 532 17 52-42 | Socket Asm Bulb Twistlock |
| 90 | 532 40 07-25 | Cover Terminal |
| 101 | 532 19 83-17 | Harness Pigtail |
| 102 | 532 40 44-54 | Harness Pigtail |
| 103 | 532 40 79-62 | Harness 12-Volt Pigtail |
| 105 | 532 40 75-68 | Switch Reverse TT Pedal Control |

NOTE: All component dimensions given in U.S. inches
1 inch = 25.4 mm

**TRACTOR - - MODEL NUMBER 2042LS (96043004800), PRODUCT NO. 960 43 00-48
CHASSIS**

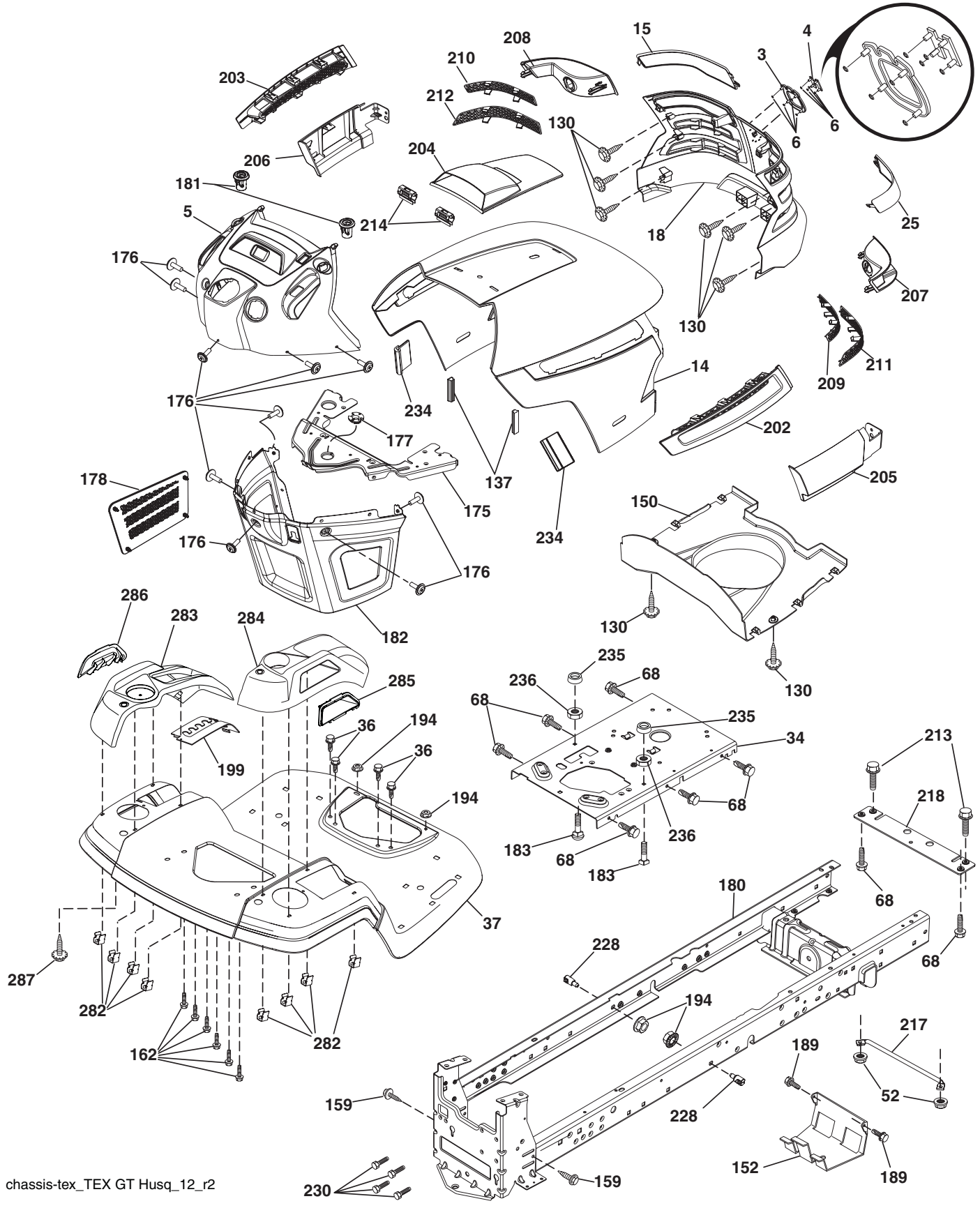

chassis-tex_TEX GT Husq_12_r2

**TRACTOR - - MODEL NUMBER 2042LS (96043004800), PRODUCT NO. 960 43 00-48
CHASSIS**

| KEY NO. | PART NO. | DESCRIPTION | KEY NO. | PART NO. | DESCRIPTION |
|----------------|-----------------|----------------------------------|----------------|-----------------|-----------------------|
| 3 | 532 40 86-06 | Trim, Husq. | 203 | 532 40 30-76 | Vent Side Hood LH |
| 4 | 532 40 50-12 | Logo | 204 | 532 41 66-13 | Vent Top Hood |
| 5 | 532 40 87-01 | Dash | 205 | 532 40 17-09 | Skirt Hood Side RH |
| 6 | 532 11 04-52 | Nut, Push | 206 | 532 40 17-11 | Skirt Hood Side LH |
| 14 | 532 41 10-46 | Hood | 207 | 532 19 71-98 | Bezel RH |
| 15 | 532 19 89-07 | Lens LH | 208 | 532 19 71-99 | Bezel LH |
| 18 | 532 40 86-07 | Grille/Lens Asm. | 209 | 532 19 91-30 | Insert Hex Top RH |
| 25 | 532 19 89-06 | Lens RH | 210 | 532 19 91-31 | Insert Hex Top LH |
| 34 | 532 19 61-25 | Plate Engine | 211 | 532 19 91-32 | Insert Hex Bottom RH |
| 36 | 817 06 05-12 | Screw 5/16-18 x 3/4 | 212 | 532 19 91-33 | Insert Hex Bottom LH |
| 37 | 532 41 63-07 | Fender | 213 | 874 76 05-12 | Bolt 5/16-18 x 3/4 |
| 52 | 873 68 05-00 | Nut Lock 5/16-18 | 214 | 532 19 91-45 | Clip Retainer Tinner |
| 68 | 817 49 05-08 | Screw Thdrol 5/16-18 x 1/2 | 217 | 532 40 91-67 | Rod Pivot |
| 130 | 532 41 63-58 | Screw 10 x 0.750 BOS Thread | 218 | 532 19 63-95 | X-Piece Hood Stop |
| 137 | 532 40 75-90 | Bumper Dash | 228 | 532 19 51-61 | Stud Fastner |
| 150 | 532 19 85-12 | Air Duct | 230 | 532 17 01-65 | Bolt Shoulder 5/16-18 |
| 152 | 532 19 95-35 | Shield Browning | 234 | 532 40 47-42 | Bumper Hood |
| 159 | 817 00 06-12 | Screw 3/8-16 x 3/4 | 235 | 532 40 61-29 | Spacer Fender |
| 175 | 532 19 63-04 | Crossmember | 236 | 873 93 05-00 | Nut Lock 5/16-18 unc |
| 176 | 532 40 07-76 | Screw 10-24 x 5/8 | 282 | 532 41 41-10 | Clip Retainer Console |
| 177 | 532 19 52-27 | Bushing Steering | 283 | 532 41 63-16 | Console Deck Lift |
| 178 | 532 19 97-82 | Cargo Net Asm. | 284 | 532 41 78-87 | Console Shift |
| 180 | 532 19 54-57 | Chassis | 285 | 532 41 63-15 | Console Insert RH |
| 181 | 532 40 30-25 | Bushing Mtg. Fender Crgo | 286 | 532 41 63-17 | Console Insert LH |
| 182 | 532 40 68-59 | Dash Lower | 287 | 817 60 04-06 | Screw 1/4-20 X 3/8 |
| 183 | 874 78 05-20 | Bolt Fin Hex 5/16-18 unc x 1-1/4 | | | |
| 189 | 817 00 05-12 | Screw 5/16-18 x 3/4 | | | |
| 194 | 873 90 05-00 | Nut Lock Hex Flange 5/16-18 | | | |
| 199 | 532 41 34-85 | Plate Deck Lift | | | |
| 202 | 532 40 30-48 | Vent Side Hood RH | | | |

NOTE: All component dimensions given in U.S. inches
1 inch = 25.4 mm

TRACTOR - - MODEL NUMBER 2042LS (96043004800), PRODUCT NO. 960 43 00-48
DRIVE

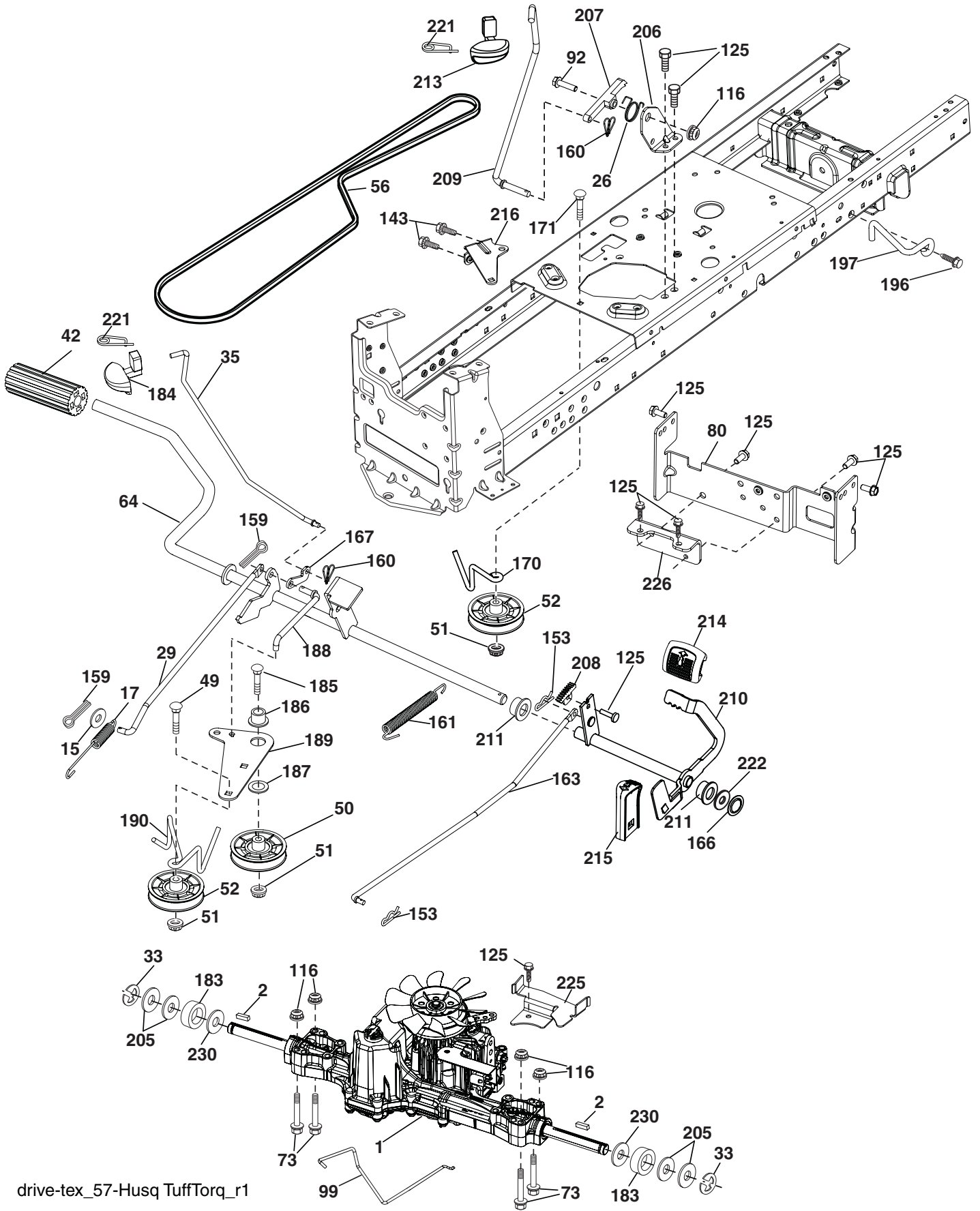

drive-tex_57-Husq TuffTorq_r1

**TRACTOR - - MODEL NUMBER 2042LS (96043004800), PRODUCT NO. 960 43 00-48
DRIVE**

| KEY NO. | PART NO. | DESCRIPTION | KEY NO. | PART NO. | DESCRIPTION |
|----------------|-----------------|---|----------------|-----------------|-------------------------------|
| 1 | 532 40 53-84 | Transaxle, TUFFTORQ K46BT (Internal parts not available) | 171 | 872 11 06-16 | Bolt RDHD SQNK 3/8-16 unc x 2 |
| 2 | 532 12 35-83 | Key | 183 | 532 13 70-57 | Spacer Split |
| 15 | 819 13 13-16 | Washer 13/32 x 13/16 x 16 Ga. | 184 | 532 40 31-18 | Handle Parking Brake |
| 17 | 532 41 36-78 | Spring, Brake | 185 | 872 11 06-20 | Bolt Rdhd Sqnk 3/8-16 x 2-1/2 |
| 26 | 532 19 96-79 | Spring Return Cruise | 186 | 532 19 43-21 | Spacer Retainer |
| 29 | 532 40 38-06 | Rod, Brake | 187 | 819 13 32-10 | Washer |
| 33 | 812 00 00-01 | Ring E | 188 | 532 19 43-23 | Link Clutch Ground Drive |
| 35 | 532 19 95-91 | Rod, Brake, Park | 189 | 532 19 43-17 | Bellcrank Ground Drive |
| 42 | 532 12 48-72 | Cover, Foot Pedal | 190 | 532 19 43-18 | Keeper Bellcrank Ground Drive |
| 49 | 872 11 06-14 | Bolt | 196 | 817 00 06-16 | Screw 3/8-16 x 1 |
| 50 | 532 19 43-27 | Pulley Idler Flat | 197 | 532 19 58-04 | Bracket Clutch Anti-Rotation |
| 51 | 873 90 06-00 | Lock Nut 3/8-16 | 205 | 532 12 17-48 | Washer |
| 52 | 532 19 43-26 | Idler V-Groove 910" Offset | 206 | 532 19 78-67 | Bracket Mount Latch Cruise |
| 56 | 532 13 09-69 | V-Belt, Drive | 207 | 532 19 78-68 | Latch Control Cruise |
| 64 | 532 19 78-65 | Shaft Asm. Pedal Brake Control | 208 | 532 19 78-69 | Gear Sector Control Cruise |
| 73 | 874 49 05-44 | Bolt Hex Flghd 5/16-18 Gr. 5 | 209 | 532 19 95-92 | Rod Control Cruise |
| 80 | 532 41 21-70 | Bracket Strap Torque | 210 | 532 40 09-80 | Rocker Asm. Pedal Control |
| 92 | 874 76 05-20 | Bolt Fin Hex 5/16-18 unc x 1.25 | 211 | 532 12 01-83 | Bearing Nylon |
| 99 | 532 41 57-42 | Rod Spring Bypass | 213 | 532 40 31-19 | Knob Control Cruise |
| 116 | 873 90 05-00 | Nut Lock Hex Flange 5/16-18 | 214 | 532 41 68-63 | Pedal Forward |
| 125 | 817 00 05-12 | Screw 5/16-18 x 3/4 | 215 | 532 40 17-23 | Pedal Reverse |
| 143 | 817 49 05-08 | Screw 5/16-18 x 1/2 | 216 | 532 19 61-31 | Bracket Pulley Idler |
| 153 | 532 12 47-88 | Retainer Spring | 221 | 532 40 31-87 | Retainer Spring Clip Handle |
| 159 | 876 02 04-12 | Pin Cotter 1/8 x 3/4 | 222 | 879 21 20-10 | Washer 21/32 x 1-1/4 x 10 Ga. |
| 160 | 532 16 94-84 | Retainer Clip | 225 | 532 40 33-19 | Keeper Belt Trans. |
| 161 | 532 10 75-09 | Spring, Return, Clutch | 226 | 532 40 15-64 | Bracket Mount Torque |
| 163 | 532 40 10-34 | Rod Pedal Control | 230 | 532 18 89-67 | Washer Hardened |
| 166 | 532 19 72-90 | Nut Push | | | |
| 167 | 532 40 52-57 | Latch Brake Parking | | | |
| 170 | 532 19 43-22 | Keeper Belt Centerspan | | | |

NOTE: All component dimensions given in U.S. inches
1 inch = 25.4 mm

TRACTOR - - MODEL NUMBER 2042LS (96043004800), PRODUCT NO. 960 43 00-48
ENGINE

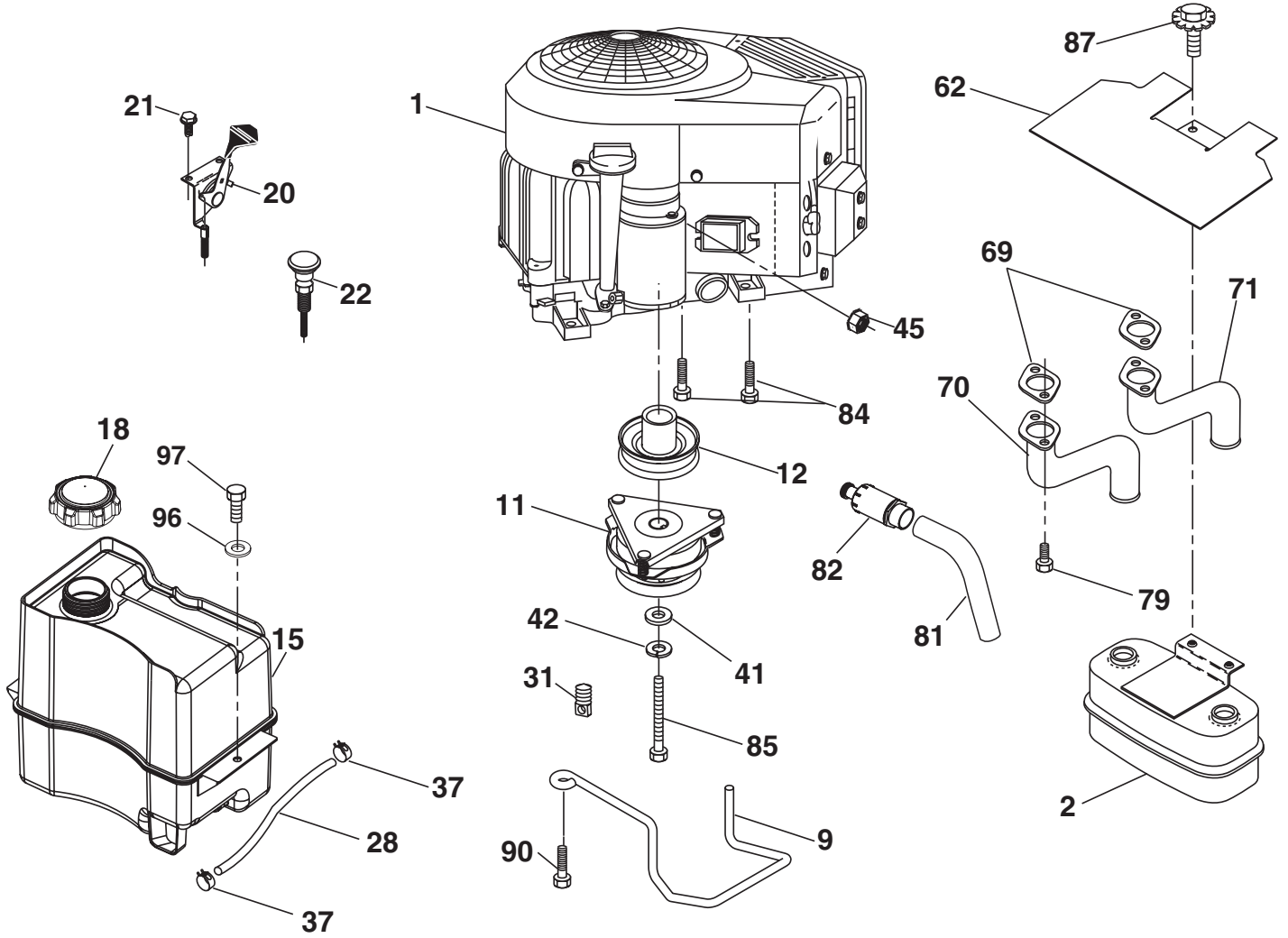

29

SPARK ARRESTER KIT

engine-tex_bs-2cyl_7

**TRACTOR - - MODEL NUMBER 2042LS (96043004800), PRODUCT NO. 960 43 00-48
ENGINE**

| KEY NO. | PART NO. | DESCRIPTION |
|----------------|-----------------|--------------------------------------|
| 1 | ----- | Engine Briggs Model No. 40G777 |
| 2 | 532 14 97-23 | Muffler |
| 9 | 532 19 43-20 | Keeper Belt Engine |
| 11 | 532 18 05-05 | Clutch Electric |
| 12 | 532 40 50-97 | Pulley Engine |
| 15 | 532 40 74-89 | Tank Fuel |
| 18 | 532 19 77-25 | Cap Asm |
| 20 | 532 17 83-85 | Control Throttle |
| 21 | 532 41 63-58 | Screw #10 x .750 BOS Thread |
| 22 | 532 18 95-91 | Choke Control |
| 28 | 532 40 11-37 | Fuel Line |
| 29 | 532 13 71-80 | Spark Arrester Kit |
| 31 | 532 14 50-06 | Clip Push-in Hinged |
| 37 | 532 12 34-87 | Clamp Hose |
| 41 | 532 12 61-97 | Washer 1-1/2 OD x 15/32 ID x .250 |
| 42 | 810 04 07-00 | Washer Lock 7/16 |
| 45 | 873 51 04-00 | Nut Keps Hex 1/4-20 unc |
| 62 | 532 14 66-29 | Heat Shield |
| 69 | 532 16 53-91 | Gasket |
| 70 | 532 15 99-55 | Tube Exhaust |
| 71 | 532 16 05-89 | Exhaust Tube |
| 79 | 532 18 39-06 | Screw Socket HP 5/16-18 x 1 |
| 81 | 532 14 84-56 | Tube Drain Oil Easy |
| 82 | 532 18 16-54 | Plug Drain Oil |
| 84 | 817 06 06-20 | Screw 3/8-16 x 1-1/4 |
| 85 | 532 17 39-37 | Bolt Hex 7/16-20 x 4 x Gr. 5-1.5 Thr |
| 87 | 537 17 18-77 | Bolt 5/16-18 unc x 3/4 w/Sems |
| 90 | 817 00 06-16 | Screw 3/8-16 x 1 |
| 96 | 819 09 14-16 | Washer 9/32 x 7/8 x 16 Ga. |
| 97 | 817 67 04-12 | Screw 1/4-20 x 3/4 |

NOTE: All component dimensions given in U.S. inches
1 inch = 25.4 mm

For engine service and replacement parts, call the toll free number for your engine manufacturer listed below:

Briggs & Stratton 1-800-233-3723

Engine Power Rating Information

The gross power rating for individual gas engine models is labeled in accordance with SAE (Society of Automotive Engineers) code J11940 (Small Engine Power & Torque Rating Procedure), and rating performance has been obtained and corrected in accordance with SAE J1995 (Revision 2002-5). Actual gross engine power will be lower and is affected by, among other things, ambient operating conditions and engine-to-engine variability. Given both the wide array of products on which engines are placed and the variety of environmental issues applicable to operating the equipment, the gas engine will not develop the rated gross power when used in a given piece of power equipment (actual "on-site" or net horsepower). This difference is due to a variety of factors including, but not limited to, accessories (air cleaner, exhaust, charging, cooling, carburetor, fuel pump, etc.), application limitations, ambient operating conditions (temperature, humidity, altitude), and engine-to-engine variability. Due to manufacturing and capacity limitations, Briggs & Stratton may substitute an engine of higher rated power for this Series engine.

**TRACTOR - - MODEL NUMBER 2042LS (96043004800), PRODUCT NO. 960 43 00-48
STEERING ASSEMBLY**

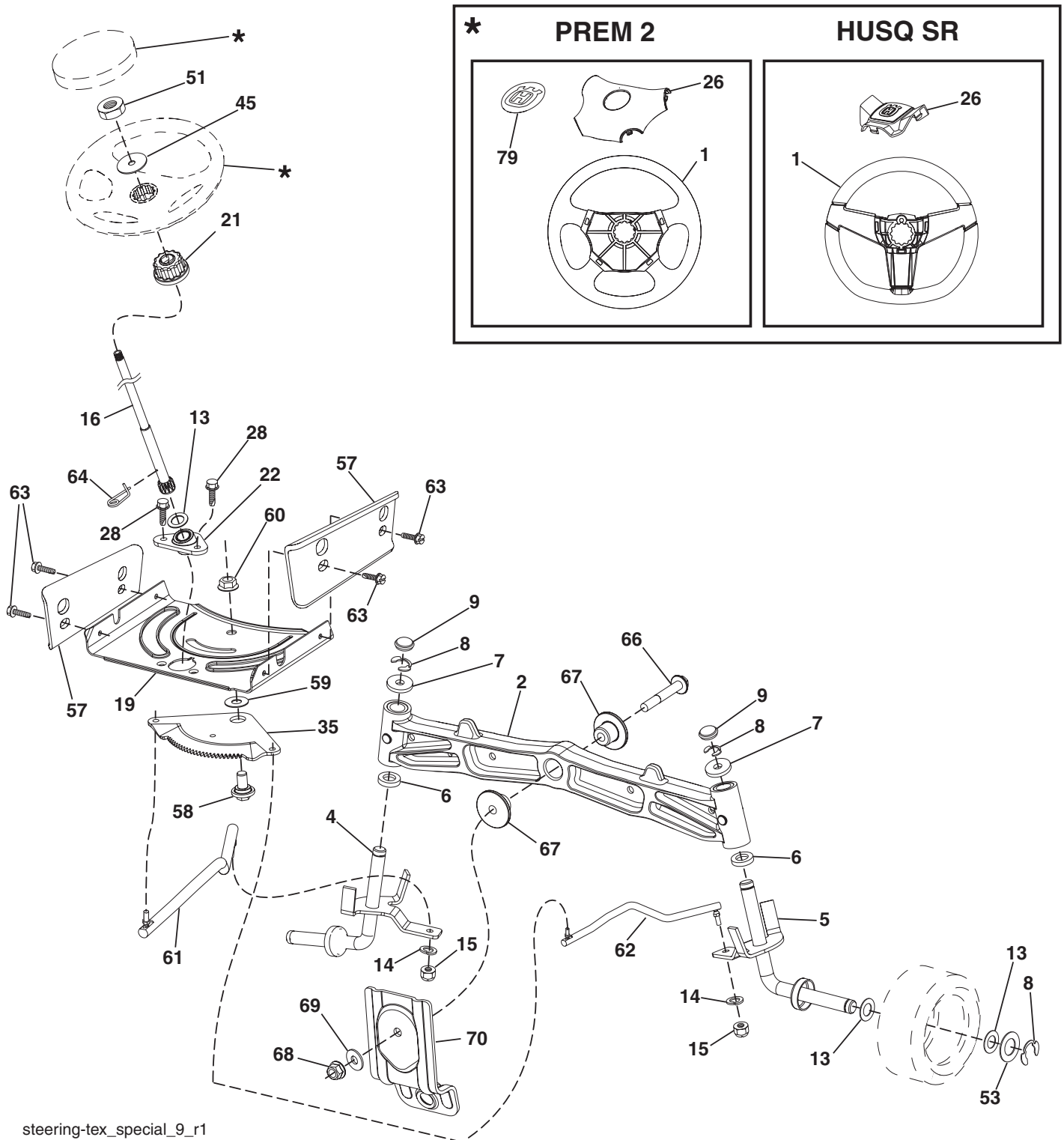

steering-tex_special_9_r1

**TRACTOR - - MODEL NUMBER 2042LS (96043004800), PRODUCT NO. 960 43 00-48
STEERING ASSEMBLY**

| KEY NO. | PART NO. | DESCRIPTION |
|----------------|-----------------|----------------------------------|
| 1 | 532 41 64-80 | Wheel, Steering |
| 2 | 532 18 47-06 | Axle Asm., Front |
| 4 | 532 40 30-87 | Spindle Asm., LH |
| 5 | 532 40 30-88 | Spindle Asm., RH |
| 6 | 532 12 49-31 | Bearing, Race Thrust Harden |
| 7 | 532 12 17-48 | Washer 25/32 x 1-5/8 x 16 Ga. |
| 8 | 812 00 00-29 | Ring, Clip #T5304-75 |
| 9 | 532 12 12-32 | Cap, Spindle |
| 13 | 532 12 17-49 | Washer 25/32 x 1-1/4 x 16 Ga. |
| 14 | 810 04 06-00 | Washer, Lock Hvy Hlcl Spr 3/8 |
| 15 | 873 54 06-00 | Nut, Crown Lock 3/8-24 unf |
| 16 | 532 40 82-19 | Shaft Steering |
| 19 | 532 19 47-29 | Plate Steering |
| 21 | 532 18 67-37 | Adapter, Wheel Steering |
| 22 | 532 19 48-45 | Bushing, Strg. Blk |
| 26 | 532 41 59-87 | Insert, Wheel Steering |
| 28 | 817 00 06-12 | Screw 3/8-16 x 3/4 |
| 35 | 532 19 47-32 | Gear, Sector Plate |
| 45 | 819 18 38-12 | Washer 9/16 ID x 2-3/8 OD 12 Ga. |
| 51 | 873 94 08-00 | Nut Hex Jam Toplock 1/2-20 unf |
| 53 | 532 18 89-67 | WasherHardened.793x1.637x.060 |
| 57 | 532 40 74-65 | Bracket Upstop |
| 58 | 532 19 47-47 | Bolt Shoulder Sector Pivot CFM |
| 59 | 532 19 47-48 | Washer Thrust Sector Steering |
| 60 | 873 97 10-00 | Nut Flange Lock 5/8-11 |
| 61 | 532 19 47-40 | Draglink LH |
| 62 | 532 19 47-41 | Draglink, RH |
| 63 | 817 00 05-12 | Screw 5/16-18 x 3/4 |
| 64 | 532 19 98-49 | Retainer Clip Spring Steering |
| 66 | 871 02 07-48 | Bolt Hex Fghd 7/16-14 x 3 Serr |
| 67 | 532 19 47-37 | Bushing PM Front Axle |
| 68 | 873 90 07-00 | Nut Lock Flange 7/16-14 Gr. 5 |
| 69 | 532 19 91-62 | Washer 1.5 x .505 x .118 |
| 70 | 532 19 61-97 | Bracket Deck Susp. Front |

NOTE: All component dimensions given in U.S. inches
1 inch = 25.4 mm

**TRACTOR - - MODEL NUMBER 2042LS (96043004800), PRODUCT NO. 960 43 00-48
SEAT ASSEMBLY**

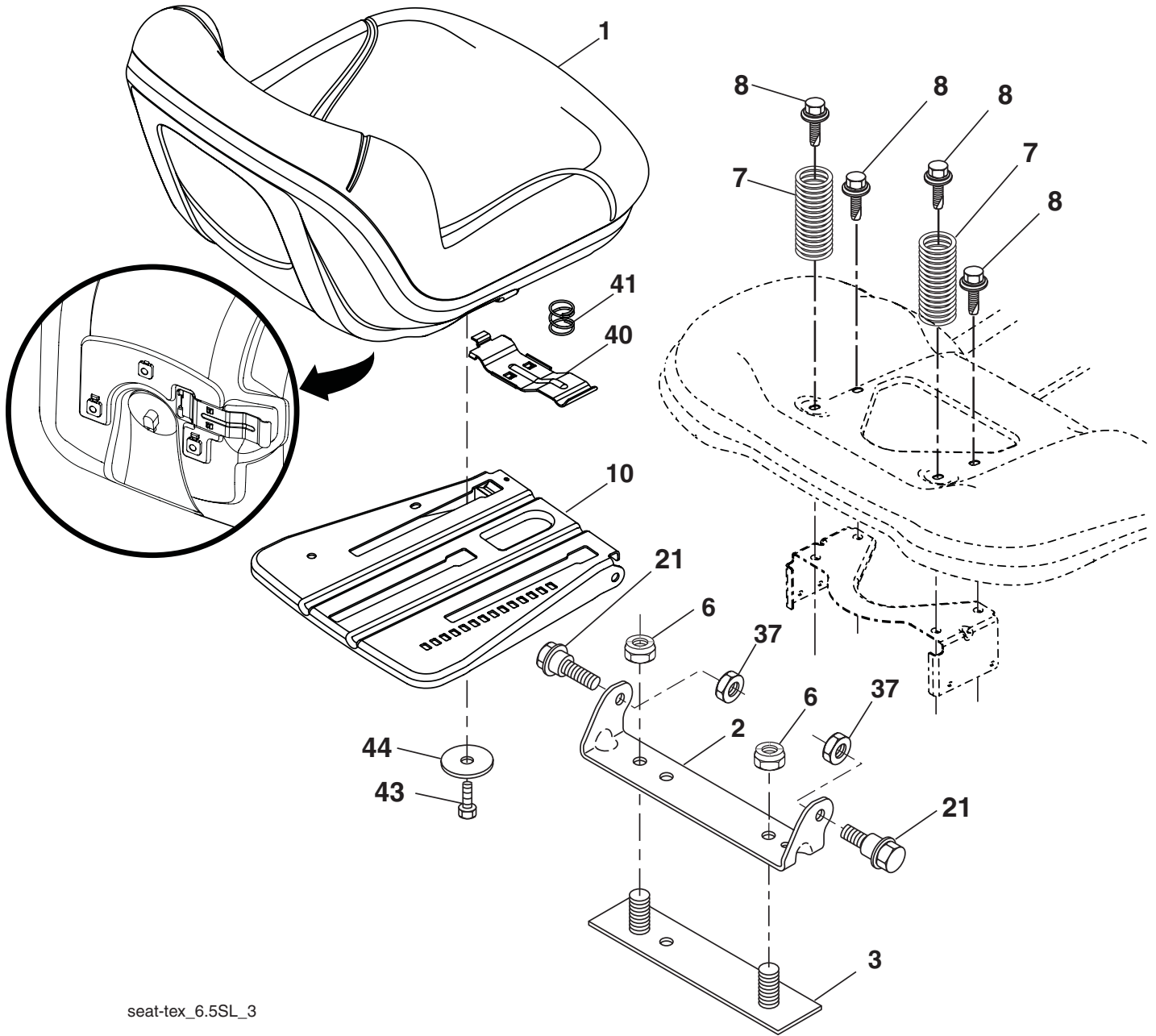

seat-tex_6.5SL_3

| KEY NO. | PART NO. | DESCRIPTION |
|---------|--------------|-------------------------------|
| 1 | 532 40 66-21 | Seat |
| 2 | 532 18 01-66 | Bracket Pivot Fender |
| 3 | 532 14 06-75 | Strap, Asm Fender |
| 6 | 873 80 06-00 | Nut, Lock w/Ins. 3/8-16 unc |
| 7 | 532 12 41-81 | Spring, Seat Cprsn |
| 8 | 532 17 18-77 | Bolt 5/16-18 unc x 3/4 w/Sems |
| 10 | 532 19 69-77 | Pan, Seat |
| 21 | 532 17 18-52 | Bolt, Shoulder 5/16-18 |

| KEY NO. | PART NO. | DESCRIPTION |
|---------|--------------|-------------------------------|
| 37 | 873 80 05-00 | Nut, Lock 5/16-18 unc |
| 40 | 532 19 76-61 | Handle Slide Seat |
| 41 | 532 19 82-00 | Spring Latch Seat |
| 43 | 874 76 06-12 | Bolt Fin Hex 3/8-16 unc x 3/4 |
| 44 | 819 13 38-12 | Washer 13/32 x 2-3/8 x 12 Ga. |

NOTE: All component dimensions given in U.S. inches
1 inch = 25.4 mm

**TRACTOR - - MODEL NUMBER 2042LS (96043004800), PRODUCT NO. 960 43 00-48
DECALS**

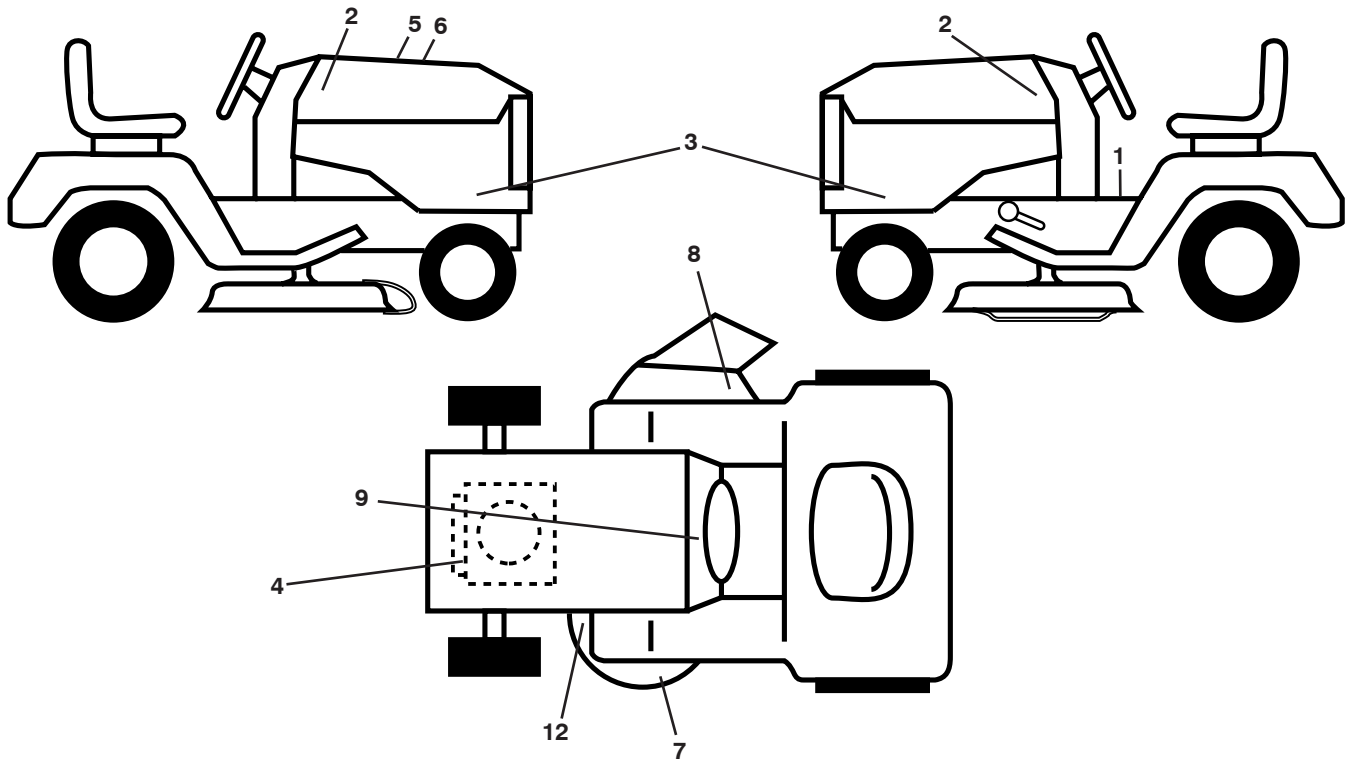

| KEY NO. | PART NO. | DESCRIPTION | KEY NO. | PART NO. | DESCRIPTION |
|---------|--------------|--------------------------|---------|--------------|--------------------------------|
| 1 | 532 41 16-58 | Decal, Operators | 8 | 532 17 05-63 | Decal Mower Warn Keep Handaway |
| 2 | 532 41 57-80 | EMBLEM, Hood | 9 | 532 14 50-05 | Decal, Battery Dnge/Poi |
| 3 | 532 41 82-11 | Decal, Emblem Panel SD | 12 | 532 16 03-96 | Decal, Mower V-Belt Schematic |
| 4 | 532 41 84-93 | Decal, Eng. | -- | 532 16 69-60 | Decal, Bypass |
| 5 | 532 18 09-41 | Decal, Customer Respons. | -- | 532 41 08-05 | Pad, Footrest, LH |
| 6 | 532 41 88-14 | Decal, Replacement | -- | 532 41 08-06 | Pad, Footrest, RH |
| 7 | 532 41 82-77 | Decal, Deck Airinduct | -- | 532 41 88-19 | Manual, Owner's (English) |
| | | | -- | 532 41 88-20 | Manual, Owner's (French) |

WHEELS AND TIRES

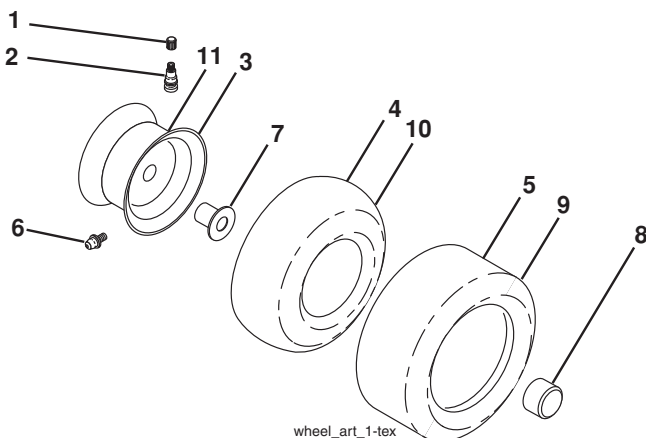

| KEY NO. | PART NO. | DESCRIPTION |
|---------|--------------|-----------------------------------|
| 1 | 532 05 91-92 | Cap Valve Tire |
| 2 | 532 06 51-39 | Stem Valve |
| 3 | 532 13 83-36 | Rim Front Service |
| 4 | 532 05 99-04 | Tube Front (Service Item Only) |
| 5 | 532 10 62-22 | Tire Front 15 x 6.0-6 Service |
| 6 | 532 12 49-57 | Fitting Grease (Front Wheel Only) |
| 7 | 532 12 49-59 | Bearing Flange (Front Wheel Only) |
| 8 | 532 17 50-39 | Cap Axle Blk 1 50 x 1 00 |
| 9 | 532 12 20-82 | Tire R T 20 x 10-8 Service |
| 10 | 532 12 49-26 | Tube Rear (Service Item Only) |
| 11 | 532 13 83-37 | Rim Asm 8" Rear Service |
| -- | 532 14 43-34 | Sealant, Tire (10 oz. Tube) |

NOTE: All component dimensions given in U.S. inches
1 inch = 25.4 mm

**TRACTOR - - MODEL NUMBER 2042LS (96043004800), PRODUCT NO. 960 43 00-48
MOWER DECK**

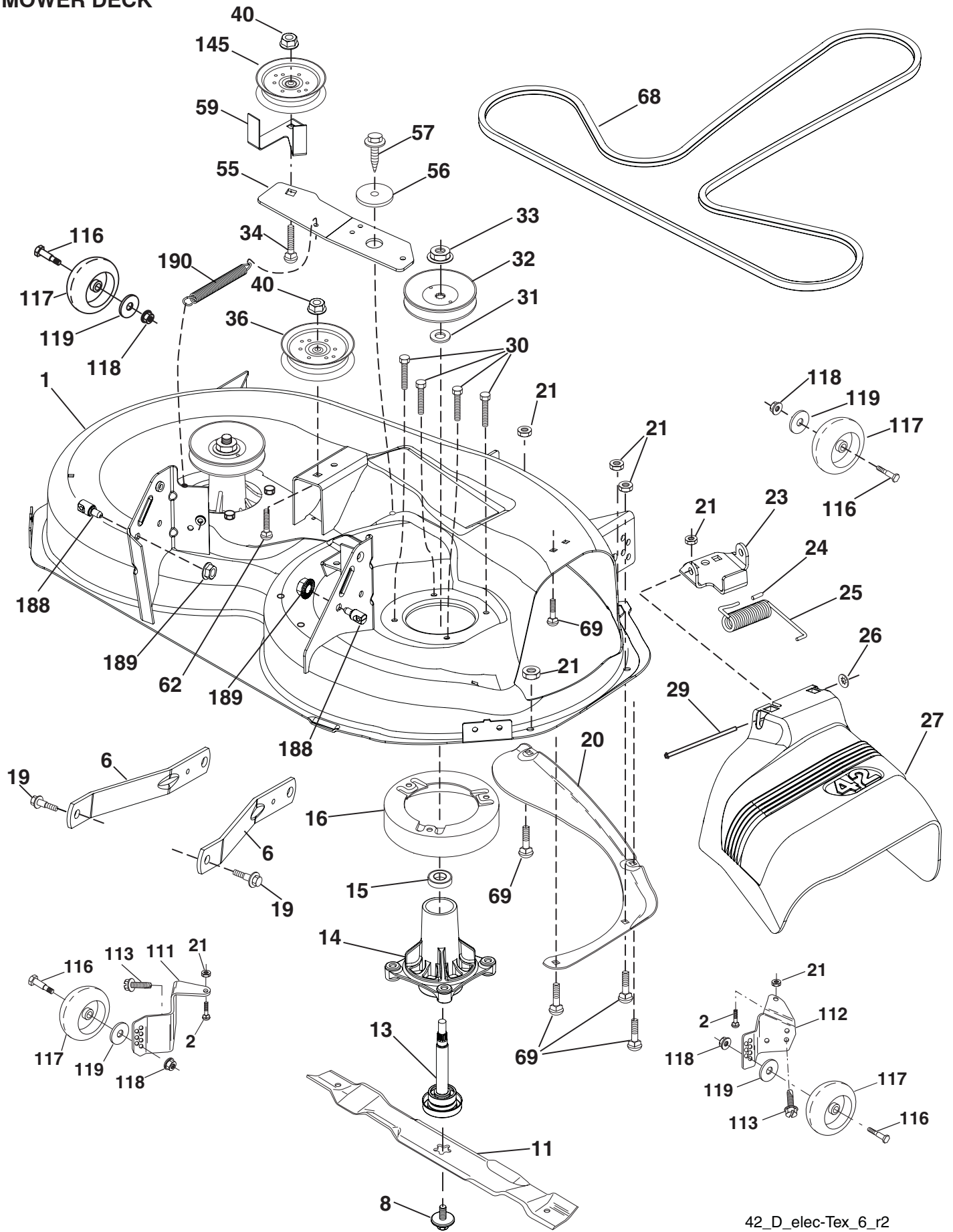

**TRACTOR - - MODEL NUMBER 2042LS (96043004800), PRODUCT NO. 960 43 00-48
MOWER DECK**

| KEY NO. | PART NO. | DESCRIPTION |
|----------------|-----------------|---|
| 1 | 532 41 86-16 | Mower Housing |
| 2 | 872 14 05-06 | Bolt, Rdhd.5QNK 5/16-18 unc x 3/4 |
| 6 | 532 19 51-86 | Arm Suspension |
| 8 | 532 19 30-03 | Bolt/Washer Asm 7/16-20 unf |
| 11 | 532 13 89-71 | Blade Mower |
| -- | 532 13 41-49 | Blade, 42", Mulching Standard |
| -- | 532 13 97-55 | Blade, 42", Mulching PREMIUM |
| 13 | 532 19 28-72 | Shaft Assembly, Mandrel |
| 14 | 532 18 72-81 | Housing, Mandrel |
| 15 | 532 11 04-85 | Bearing, Ball, Mandrel |
| 16 | 532 17 44-93 | Stripper Mandrel |
| 19 | 532 19 65-39 | Bolt, Shoulder |
| 20 | 532 15 97-70 | Baffle Vortex |
| 21 | 873 68 05-00 | Nut |
| 23 | 532 19 25-57 | Bracket, Deflector |
| 24 | 532 10 53-04 | Cap, Sleeve |
| 25 | 532 19 70-26 | Spring, Torsion, Deflector |
| 26 | 532 11 04-52 | Nut, Push |
| 27 | 532 40 30-04 | Shield, Deflector |
| 29 | 532 13 14-91 | Rod, Hinge |
| 30 | 532 17 39-84 | Screw Thdrol Rolling Wsh Hd |
| 31 | 532 18 76-90 | Washer, Spacer |
| 32 | 532 15 35-35 | Pulley, Mandrel |
| 33 | 532 40 02-34 | Nut, Toplock, Flanged |
| 34 | 872 11 06-12 | Bolt Carr Sh. 3/8-16 x1-1/2 Gr. 5 |
| 36 | 532 19 73-79 | Pulley, Idler, Flat |
| 40 | 873 90 06-00 | Nut, Lock Fig. 3/8-16 unc |
| 55 | 532 19 72-49 | Arm, Idler |
| 56 | 532 19 90-92 | Spacer, Retainer |
| 57 | 817 00 06-16 | Screw Hexwsh Thd 3/8-16 x 1 |
| 59 | 532 14 10-43 | Guard, Tuv Idler (94) |
| 62 | 872 11 06-16 | Bolt 3/8 - 16 unc x 2 |
| 68 | 532 14 49-59 | V-Belt |
| 69 | 872 14 05-05 | Bolt |
| 111 | 532 40 47-84 | Bracket Wheel Gauge LH |
| 112 | 532 40 47-85 | Bracket Wheel Gauge RH |
| 113 | 817 00 05-10 | Screw 5/16-18 |
| 116 | 532 12 48-42 | Bolt, Shoulder |
| 117 | 532 18 86-06 | Wheel, Gauge |
| 118 | 873 93 06-00 | Nut Centerlock 3/8 - 16 unc |
| 119 | 819 12 14-14 | Washer 3/8 x 7/8 x 14 Ga. |
| 145 | 532 19 31-97 | Pulley Idler |
| 188 | 532 19 51-61 | Stud Fastener |
| 189 | 873 90 05-00 | Nut Lock Hex Flange |
| 190 | 532 19 72-51 | Spring Mower Drive |
| -- | 532 19 28-70 | Mandrel Assembly (Includes housing, shaft assembly, and bearing only - pulley/nut/washer and blade bolt/washers not included) |
| -- | 532 41 82-66 | Replacement Mower, Complete |

NOTE: All component dimensions given in U.S. inches
1 inch = 25.4 mm

**TRACTOR - - MODEL NUMBER 2042LS (96043004800), PRODUCT NO. 960 43 00-48
MOWER LIFT**

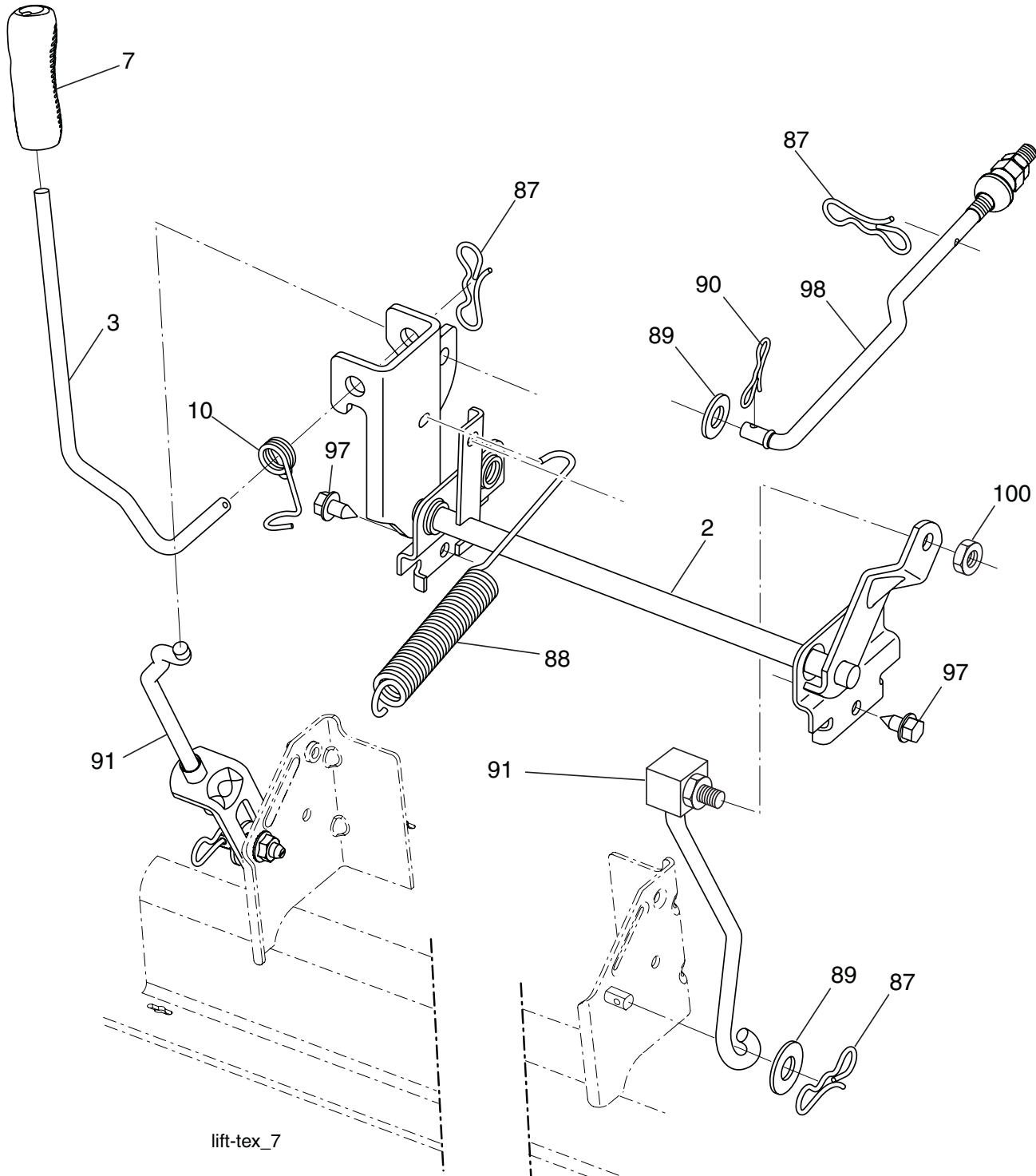

lift-tex_7

| KEY NO. | PART NO. | DESCRIPTION |
|---------|--------------|------------------------------|
| 2 | 532 19 52-23 | Shaft Asm., Lift |
| 3 | 532 19 52-31 | Lever Asm., Lift RH |
| 7 | 532 41 15-55 | Grip, Lever |
| 10 | 532 19 63-14 | Spring Torsion |
| 87 | 532 19 42-09 | Pin Cotter 7/16 Bow Tie Lock |
| 88 | 532 41 07-10 | Spring Lift Assist |
| 89 | 819 19 19-12 | Washer Clear Zinc |
| 90 | 532 19 42-08 | Pin Cotter 5/16 Bow Tie Lock |

| KEY NO. | PART NO. | DESCRIPTION |
|---------|--------------|-----------------------------|
| 91 | 532 19 51-81 | Link Lift Susp Mower Rear |
| 97 | 817 00 06-12 | Screw 3/8-16 x 3/4 |
| 98 | 532 19 52-70 | Link Lift Susp. Front Mower |
| 100 | 873 93 06-00 | Nut Center Lock 3/8-16 unc |

NOTE: All component dimensions given in U.S. inches
1 inch = 25.4 mm