

226HS75S

226HS99S

Spare parts
Ersatzteile
Pièces détachées
Reserve onderdelen
Repuestos
Reservdelar

A

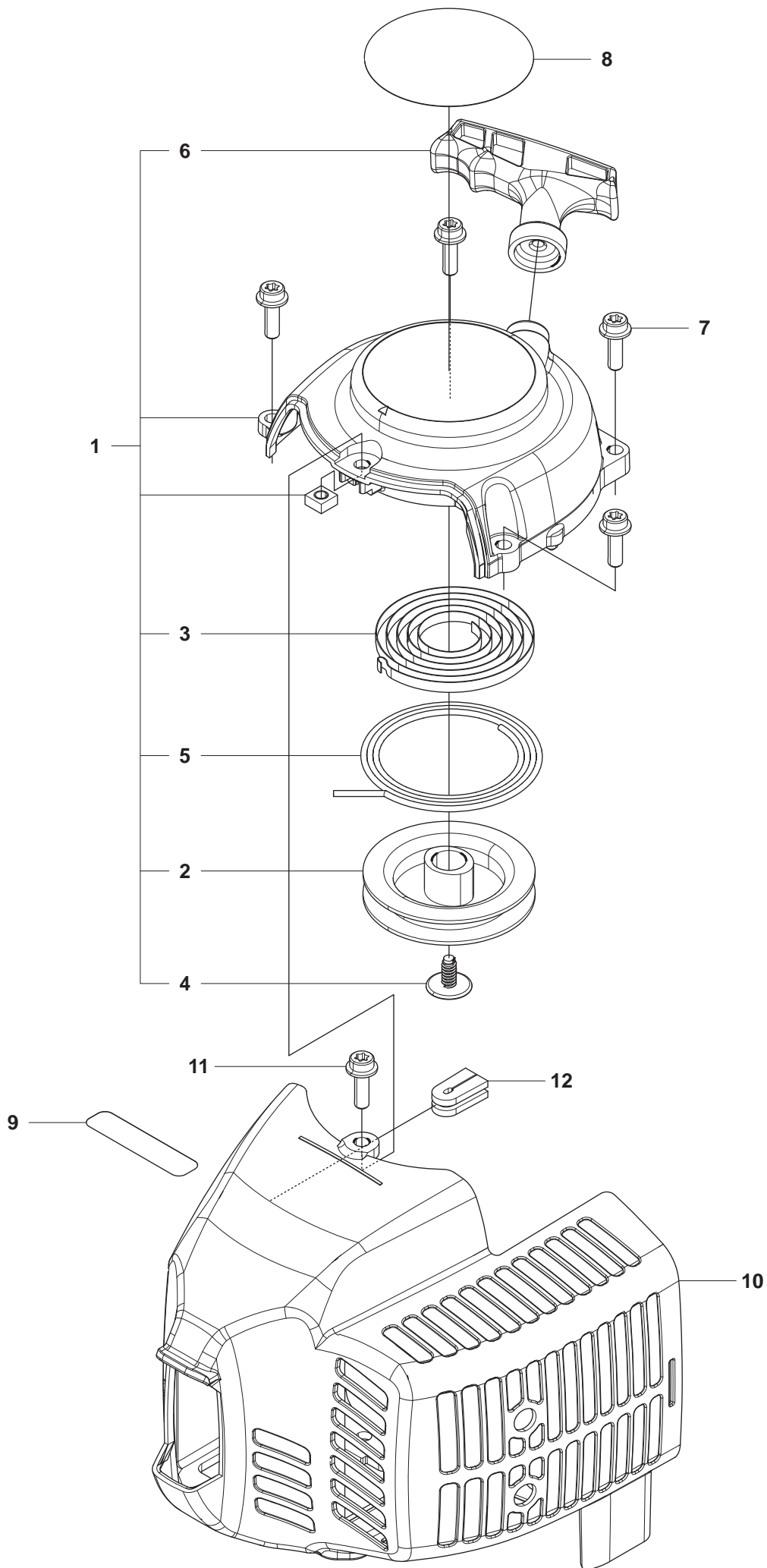

Key#	Part Number	Description	Q'ty
1	506 65 72-01	RECOIL ASSY	1
2	506 68 42-01	• REEL	1
3	506 67 43-01	• SPRING	1
4	506 61 30-01	• SCREW	1
5	506 68 34-01	• ROPE	1
6	506 61 47-01	• KNOB	1
7	506 61 65-01	BOLT TORX	4
8	506 65 74-01	LABEL, recoil	1
8	506 65 75-01	LABEL, recoil, 226HS99S	1
9	506 62 93-01	LABEL, caution	1
10	506 65 70-01	COVER, engine	1
11	506 61 65-01	BOLT TORX	1
12	506 61 59-01	GROMET	1

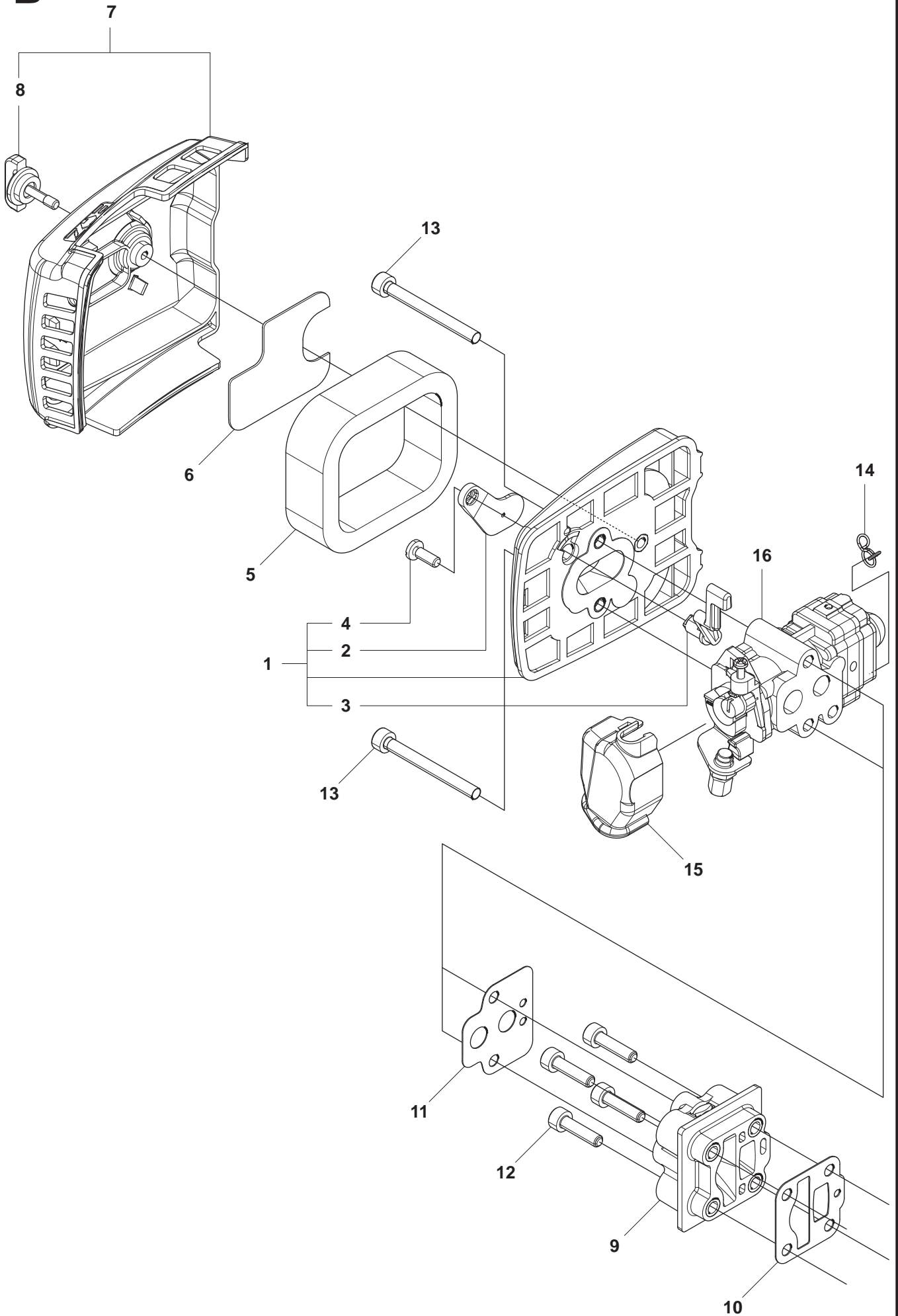
B

Key#	Part Number	Description	Q'ty
1	506 65 27-01	BODY ASSY	1
2	506 68 36-01	• PLATE, choke	1
3	506 68 37-01	• LEVER	1
4	506 61 40-01	• SCREW	1
5	506 65 29-01	ELEMENT	1
6	506 68 38-01	SCREEN	1
7	506 65 73-01	COVER ASSY	1
8	506 61 71-01	• KNOB	1
9	506 65 44-01	INSULATOR	1
10	506 65 46-01	GASKET, insu	1
11	506 65 48-01	GASKET, carb	1
12	506 68 90-01	BOLT TORX	4
13	506 61 63-01	BOLT TORX M5xL50 T27	2
14	506 61 37-01	CLIP	1
15	506 61 52-01	COVER	1
16	506 65 64-01	CARBURETOR ASSY	1

C

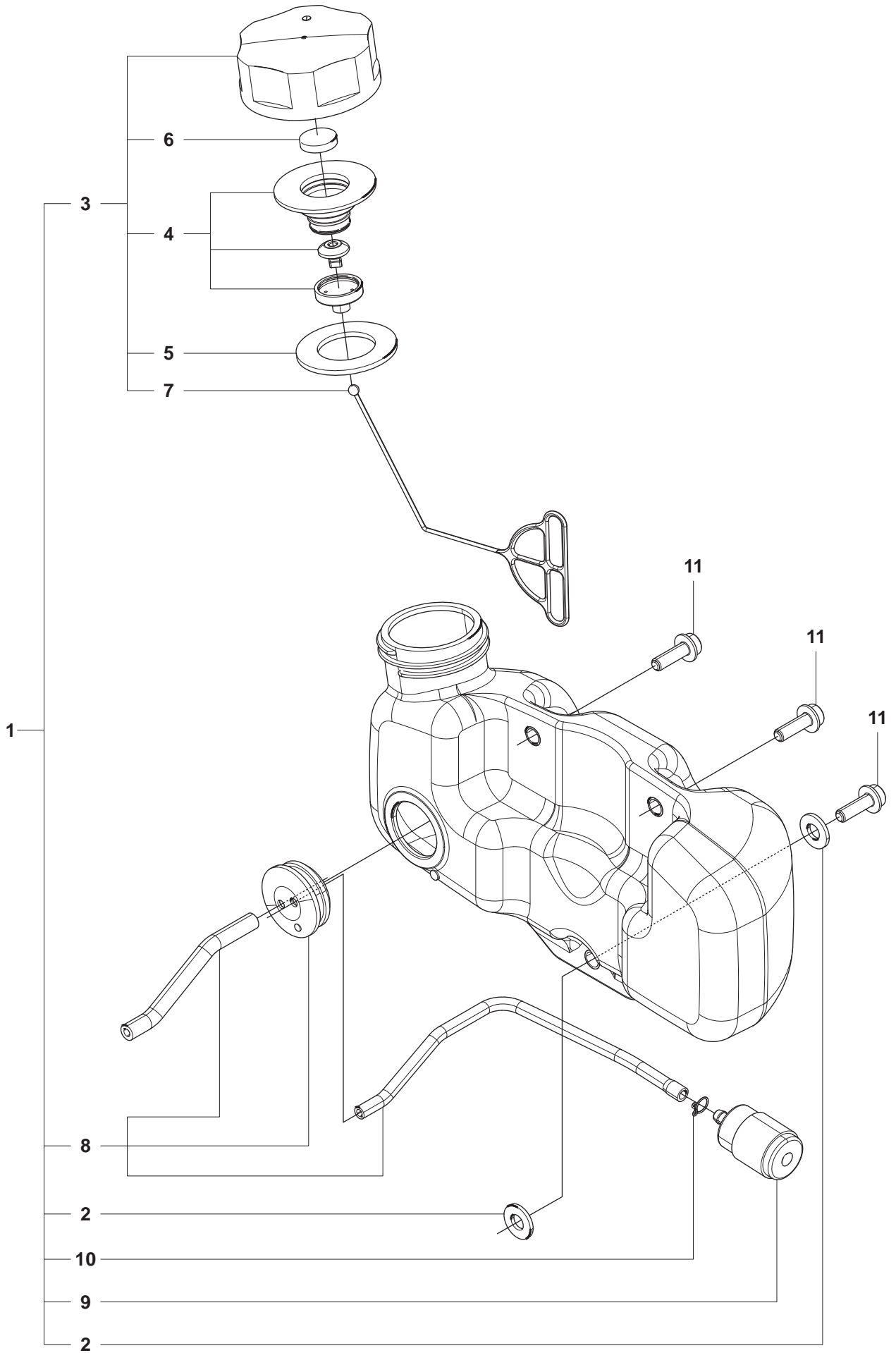

Key#	Part Number	Description	Q'ty
1	506 65 67-01	TANK ASSY	1
2	506 68 41-01	• PACKING	2
3	506 67 10-01	• CAP ASSY	1
4	506 61 54-01	•• HOLDER ASSY	1
5	506 61 53-01	•• PACKING	1
6	506 61 72-01	•• FILTER	1
7	506 61 67-01	•• STOPPER	1
8	506 65 31-01	• PIPE COMP.	1
9	506 61 46-01	• FILTER	1
10	506 61 13-01	• CLIP	1
11	506 61 65-01	BOLT TORX	3

D

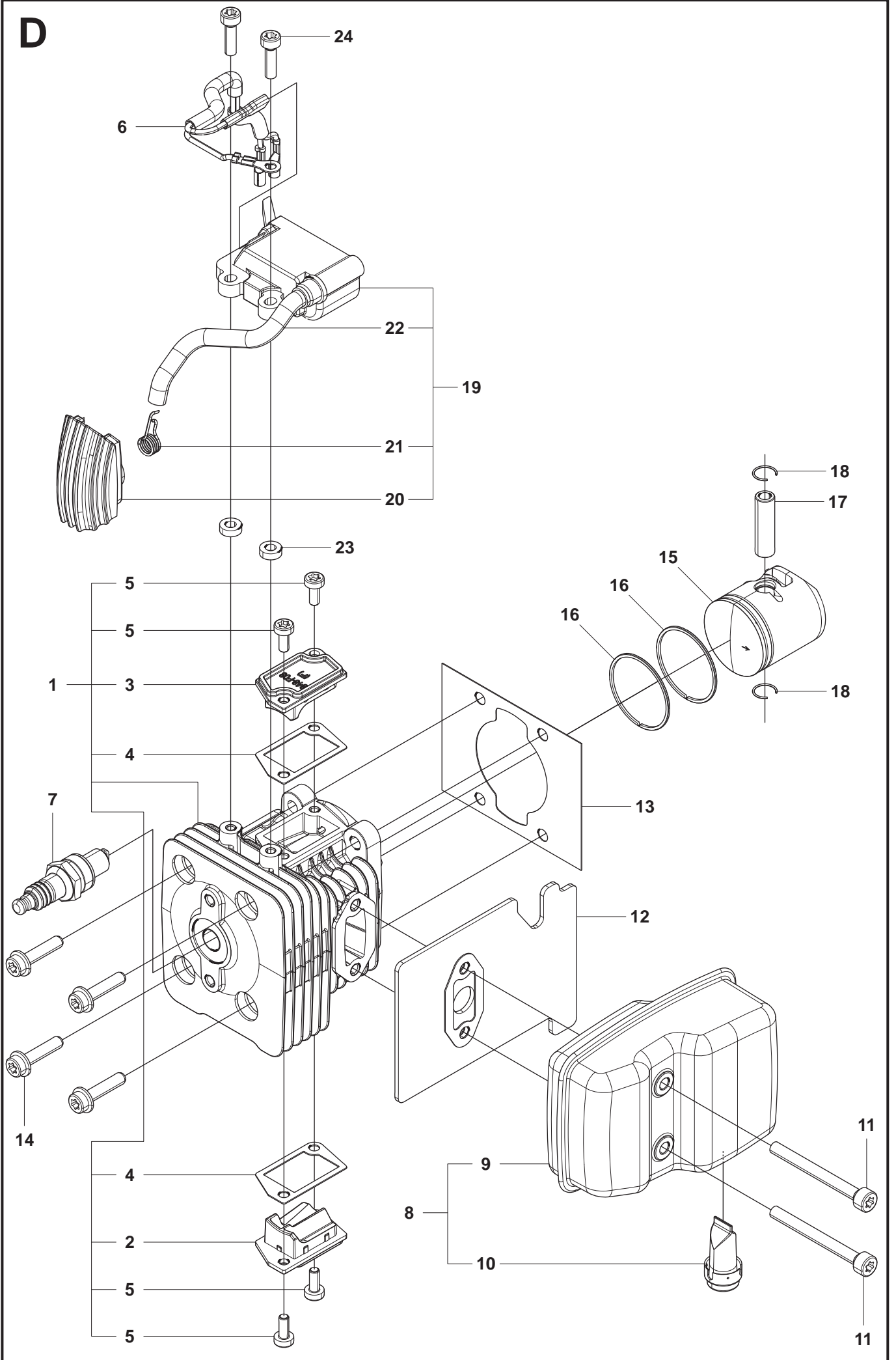

Key#	Part Number	Description	Q'ty
1	506 65 38-01	CYLINDER COMP.	1
2	506 65 41-01	• COVER, TR-S	1
3	506 65 42-01	• COVER, TR-F	1
4	506 65 43-01	• GASKET, TR	2
5	506 61 64-01	• BOLT	4
6	506 65 23-01	CORD COMP.	1
7	506 61 51-01	SPARK PLUG NGK CMR7H	1
8	506 65 68-01	MUFFLER	1
9	506 65 69-01	• MUFFLER	1
10	506 61 56-01	• ARRESTER	1
11	506 61 63-01	BOLT TORX M5xL50 T27	1
12	506 65 56-01	GASKET, muff	1
13	506 62 97-01	GASKET, base	1
14	506 61 60-01	BOLT TORX	4
15	506 65 50-01	PISTON	1
16	506 61 81-01	RING	2
17	506 61 15-01	PIN	1
18	506 61 11-01	RING	2
19	506 65 61-01	COIL ASSY	1
20	506 61 58-01	• CAP	1
21	506 65 52-01	• SPRING	1
22	506 61 82-01	• TUBE	1
23	506 61 12-01	SPACER	2
24	506 61 66-01	BOLT TORX M4xL16 T27	2

E

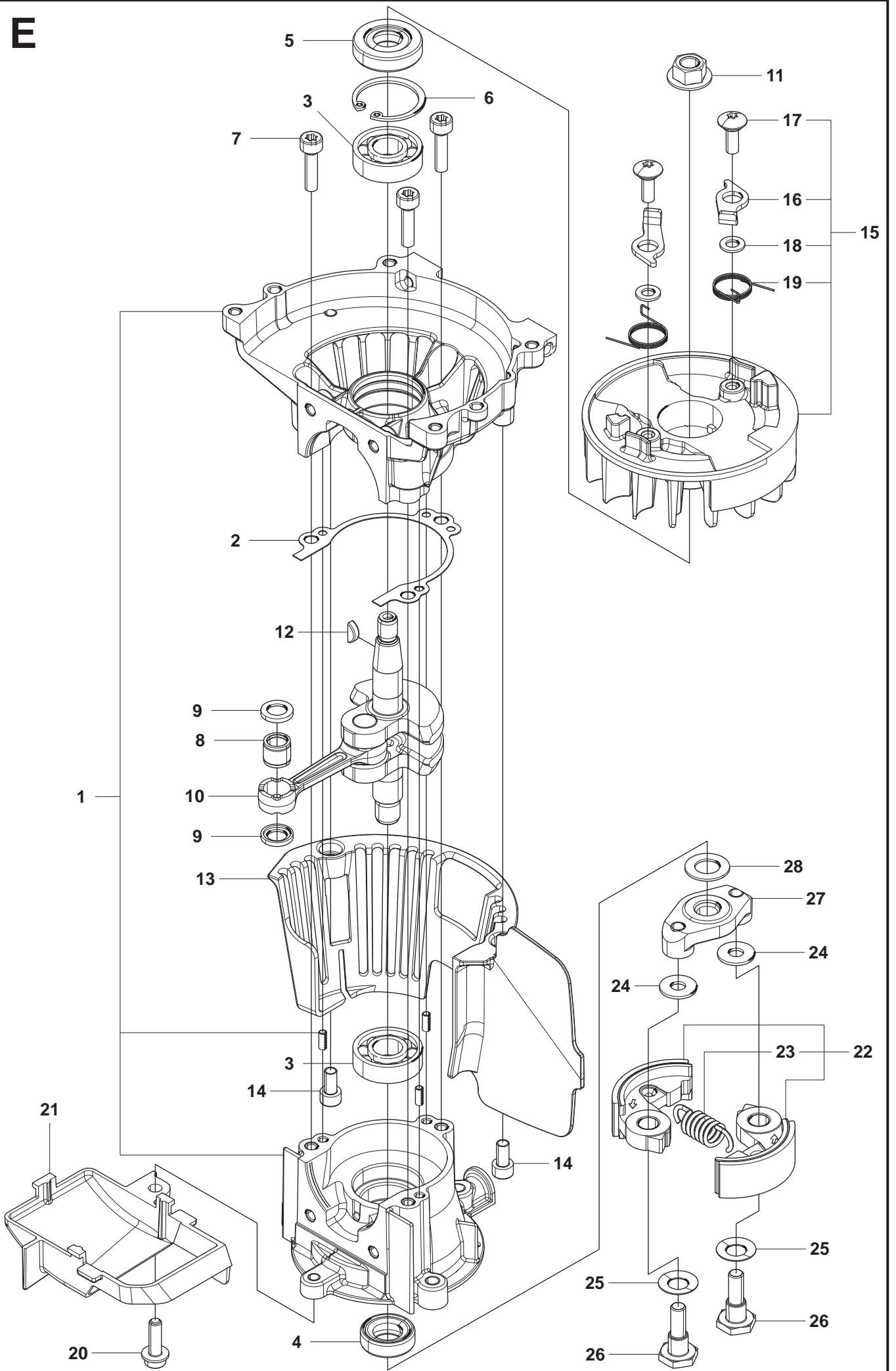

Key#	Part Number	Description	Q'ty
1	506 63 84-01	CRANKCASE COMP.	1
2	506 68 48-01	GASKET, case	1
3	506 61 03-01	BEARING	2
4	506 61 57-01	SEAL	1
5	506 61 29-01	SEAL	1
6	506 60 99-01	RING	1
7	506 61 62-01	BOLT TORX M5xL20 T27	3
8	506 68 50-01	BEARING	1
9	506 61 09-01	WASHER	2
10	506 65 18-01	CRANKSHAFT COMP.	1
11	506 61 24-01	NUT M8xP1.0	1
12	506 61 07-01	KEY	1
13	506 62 96-01	PLATE	1
14	506 61 61-01	BOLT TORX M5xL10 T27	2
15	506 65 60-01	ROTOR ASSY	1
16	506 61 41-01	• PAWL	2
17	506 61 43-01	• SCREW	2
18	506 61 44-01	• WASHER 5x10x10	2
19	506 67 43-01	• SPRING	2
20	506 61 65-01	BOLT TORX	2
21	506 65 71-01	DEFLECTOR	1
22	506 62 94-01	SHOE COMP.	1
23	506 68 58-01	• SPRING	1
24	506 61 10-01	WASHER	2
25	506 61 38-01	WASHER	2
26	506 65 22-01	SCREW	2
27	506 65 21-01	PLATE, clutch	1
28	506 61 42-01	WASHER	1

F

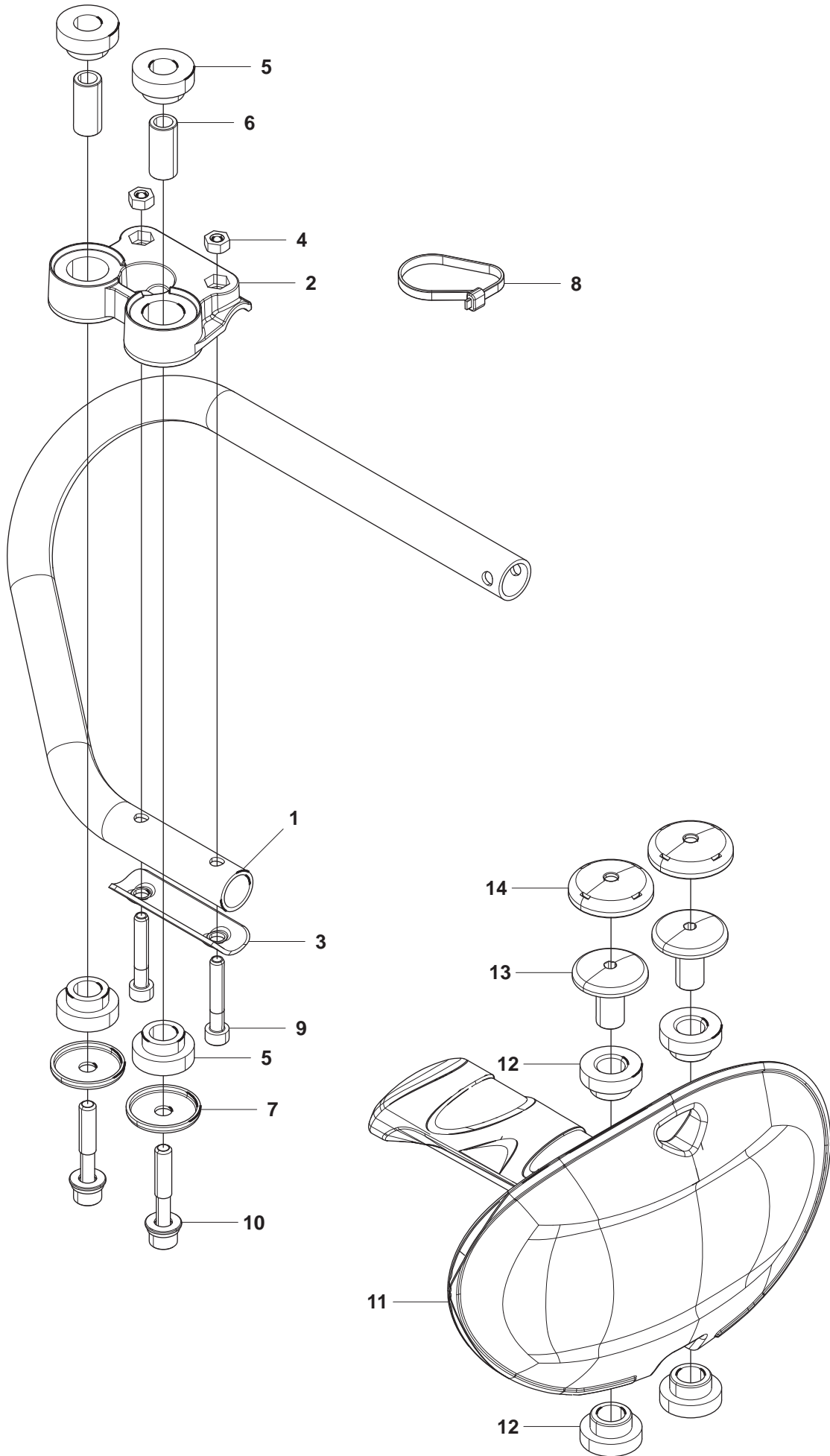

Key#	Part Number	Description	Q'ty
1	506 68 72-01	PIPE	1
2	506 68 73-01	MOUNT	1
3	506 68 74-01	PLATE	1
4	506 60 98-01	NUT	2
5	506 68 65-01	ABSORBER	4
6	506 68 71-01	COLLAR	2
7	506 68 68-01	WASHER	2
8	506 61 05-01	BAND	1
9	506 60 94-01	BOLT	2
10	506 61 49-01	BOLT	2
11	506 62 91-01	HANDLE-R COMP.	1
12	506 62 76-01	SPACER	4
13	506 68 66-01	HOLDER	2
14	506 68 67-01	CAP	2

G

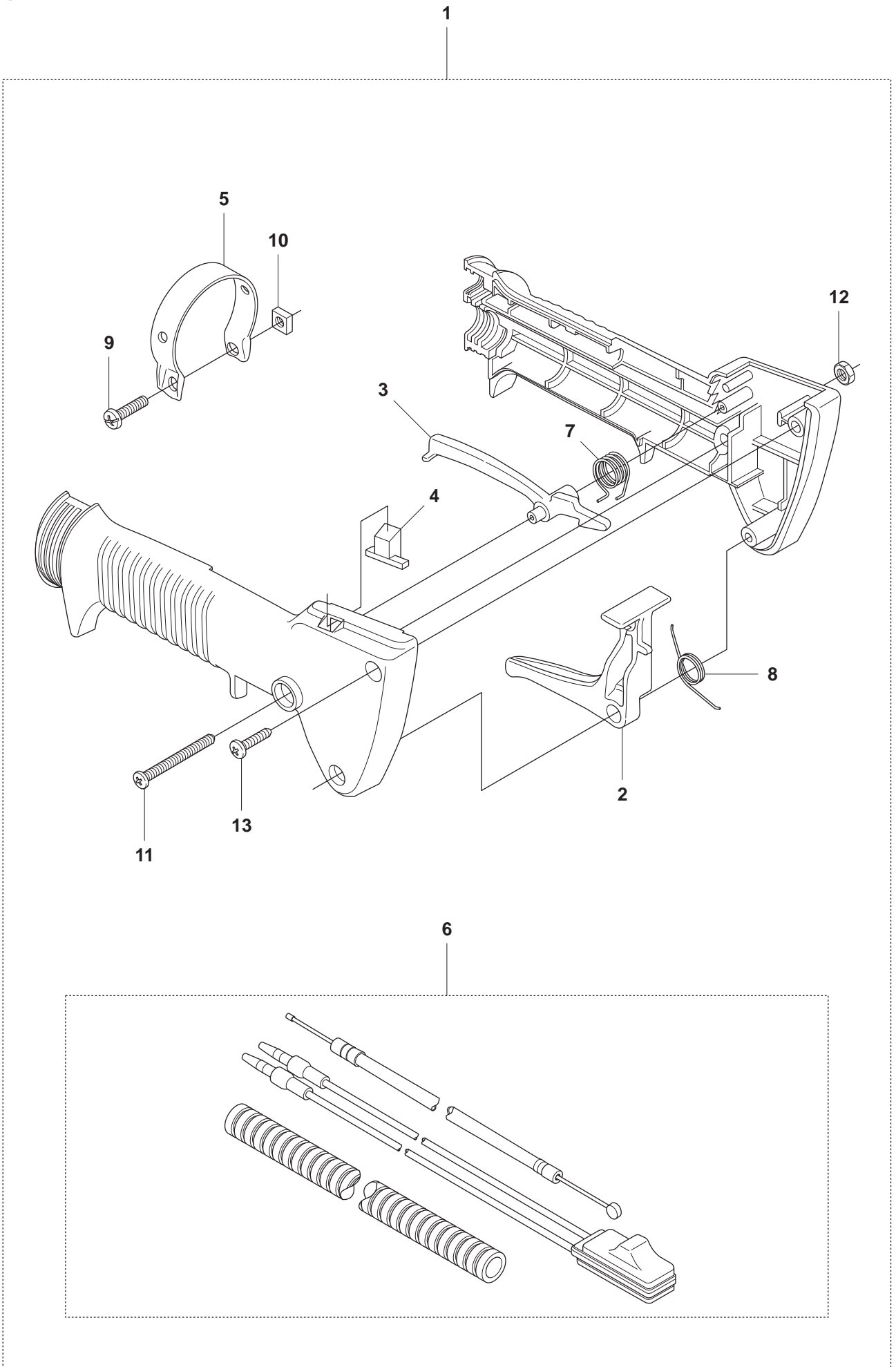

Key#	Part Number	Description	Q'ty
1	506 68 70-01	LEVER ASSY	1
2	506 61 16-01	• LEVER	1
3	506 61 17-01	• LEVER	1
4	506 61 73-01	• TOP	1
5	506 61 18-01	• CLAMP	1
6	506 68 69-01	• CABLE COMP.	1
7	506 61 19-01	• SPRING	1
8	506 61 20-01	• SPRING	1
9	506 60 97-01	• SCREW	1
10	506 61 21-01	• NUT	1
11	506 60 96-01	• SCREW	1
12	506 61 22-01	• NUT	1
13	506 61 23-01	• SCREW	1

Key#	Part Number	Description	Q'ty
1	506 61 99-01	GEARCASE COMP., upper	1
2	506 61 01-01	• BEARING	2
3	506 60 99-01	• RING	1
4	506 62 69-01	• PLATE	1
5	506 68 88-01	• BOLT	2
6	506 62 28-01	GEARCASE COMP., botom	1
7	506 62 69-01	• PLATE	1
8	506 68 88-01	• BOLT	2
9	506 68 83-01	GASKET	1
10	506 61 95-01	DRUM	1
11	506 62 72-01	GEAR, drive	1
12	506 68 87-01	GEAR, driven	1
13	506 68 85-01	ROD ASSY	2
14	506 61 45-01	FITTING	1
15	506 68 89-01	FELT	1
16	506 61 79-01	BOLT	6
17	506 60 95-01	BOLT	3
18	506 61 14-01	CLAMP	1

J

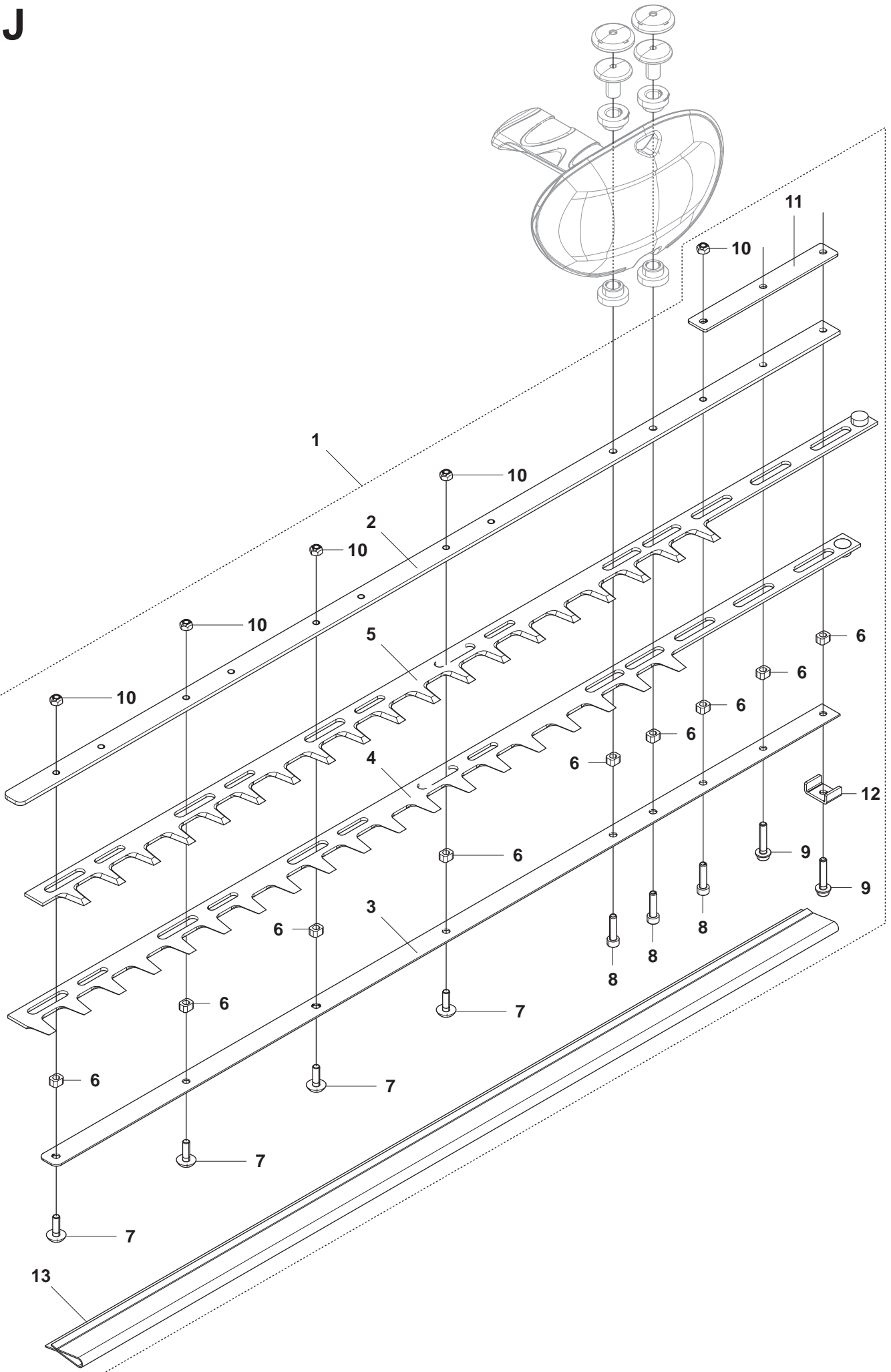

Key#	Part Number	Description	Q'ty
226HS75S			
1	506 62 77-01	BLADE ASSY	1
2	506 68 79-01	• PLATE, upper	1
3	506 68 80-01	• PLATE, lower	1
4	506 62 78-01	• BLADE, lower	1
5	506 62 79-01	• BLADE, upper	1
6	506 68 76-01	• SPACER	9
7	506 68 75-01	• SCREW	4
8	506 60 93-01	• BOLT	3
9	506 61 80-01	• BOLT	2
10	506 68 78-01	• NUT	5
11	506 68 82-01	• PLATE	1
12	506 62 74-01	• BRACKET	1
13	506 68 81-01	• COVER	1

226HS99S			
1	506 62 80-01	BLADE ASSY	1
2	506 62 83-01	• PLATE, upper	1
3	506 62 84-01	• PLATE, lower	1
4	506 62 81-01	• BLADE, lower	1
5	506 62 82-01	• BLADE, upper	1
6	506 68 76-01	• SPACER	12
7	506 68 75-01	• SCREW	7
8	506 60 93-01	• BOLT	3
9	506 61 80-01	• BOLT	2
10	506 68 78-01	• NUT	8
11	506 68 82-01	• PLATE	1
12	506 62 74-01	• BRACKET	1
13	506 62 85-01	• COVER	1

K

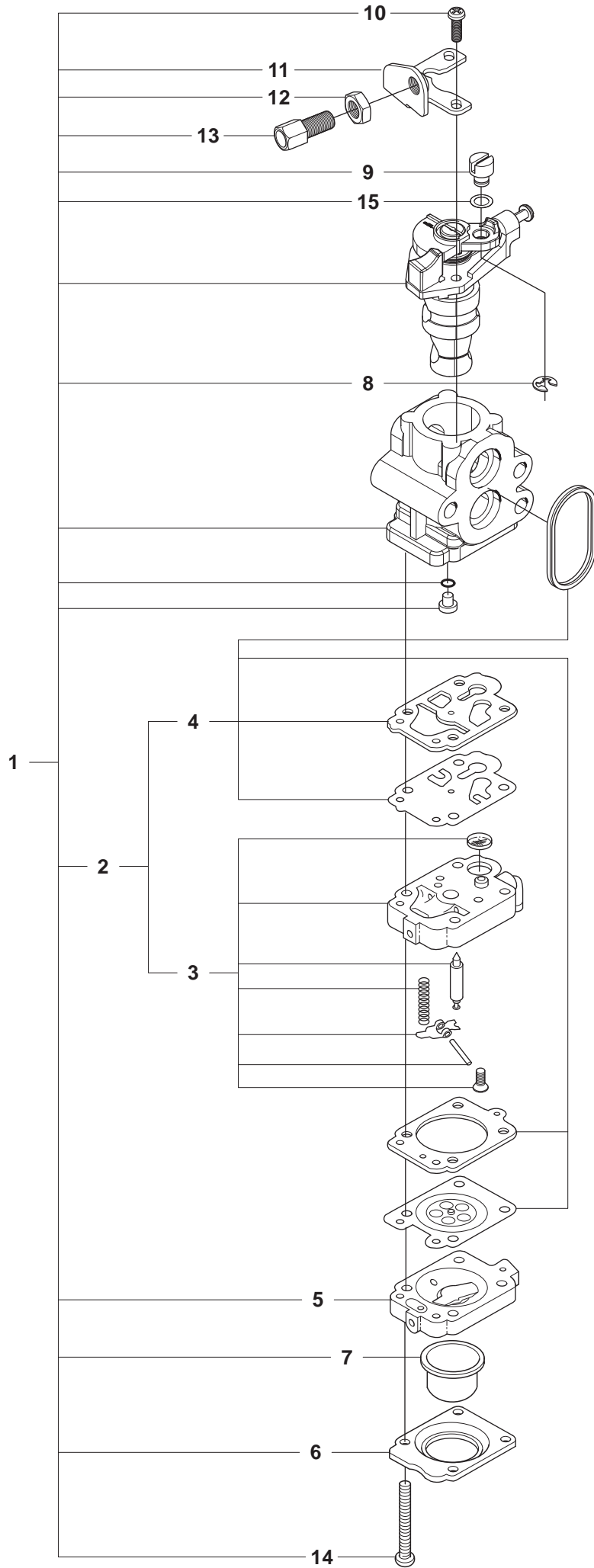

Key#	Part Number	Description	Q'ty
1	506 65 64-01	CARBURETOR ASSY	1
2	506 65 79-01	• REBUILD KIT	1
3	506 61 31-01	•• BODY ASSY	1
4	506 61 55-01	•• GASKET KIT	1
5	506 61 32-01	• BODY	1
6	506 61 33-01	• COVER	1
7	506 61 27-01	• PUMP	1
8	506 61 25-01	• RING	1
9	506 61 35-01	• SWIVEL	1
10	506 61 28-01	• SCREW	2
11	506 61 69-01	• BRACKET	1
12	506 61 26-01	• NUT	1
13	506 61 36-01	• SCREW	1
14	506 61 34-01	• SCREW	4
15	506 61 70-01	• WASHER	1

Key#	Part Number	Description	Q'ty
1	506 61 84-01	TOOL SET	1
2	506 68 61-01	• SOCKET	1
3	506 61 50-01	• SPANNER	1
4	506 61 06-01	• WRENCH	1
5	506 62 92-01	CATCHER	1
6	506 68 77-01	SCREW	4