

# LT131

**Spare parts**

**Ersatzteile**

**Pièces détachées**

**Reserve onderdelen**

**Repuestos**

**Reservdelar**

# ILLUSTRATED PARTS LIST

**MFG. ID NO. 96011026401**

**CUSTOMER CATALOG NO. LT131**

**PRODUCT NO. 960 11 02 64**

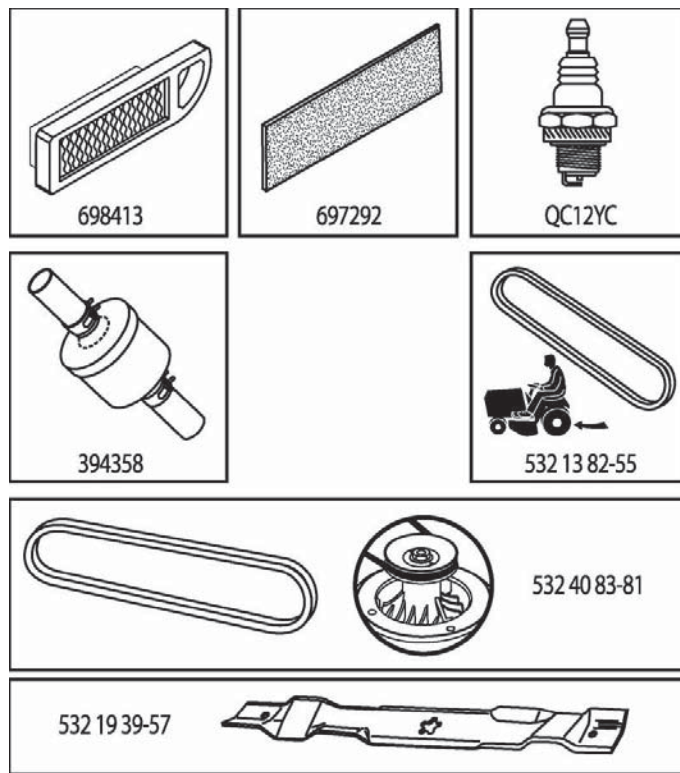

**47**

419019

**TRACTOR -- MODEL NO. LT131 (96011026401), PRODUCT NO. 960 11 02-64  
DECALS 27**

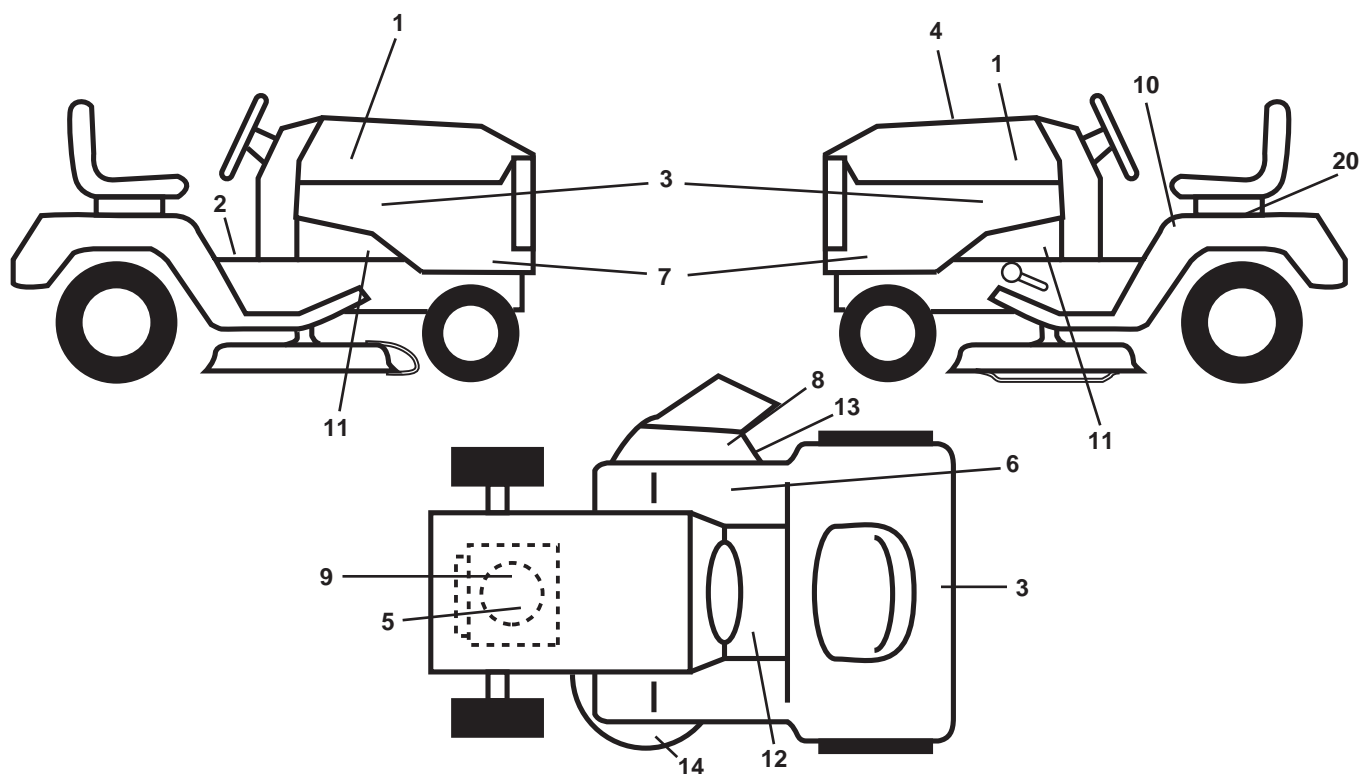

KEY NO.	PART NO.	DESCRIPTION
1	532 41 55-58	Decal Vent
2	532 14 08-37	Decal Saddle Brake Parking
3	532 40 28-32	Decal Hood
4	<b>532 41 90-19</b>	Decal Replacement
5	532 19 68-41	Decal Warning Engine
6	532 18 04-32	Decal Fender
7	532 41 55-50	Decal Pnl Side
8	532 18 21-66	Decal Mower Cutfinger
9	532 40 88-13	Decal Engine HP
10	532 40 03-89	Decal Read Owner's Manual Syms.
11	532 15 97-36	Decal Chassis Hot Muffler
12	532 15 97-37	Decal Brake/ Clutch Symbol Lt

KEY NO.	PART NO.	DESCRIPTION
13	532 19 63-57	Decal Warning
14	532 19 43-02	Decal V-Belt Schematic
20	532 14 50-05	Decal Bat Dan/Psn
--	532 16 25-98	Decal Drawbar
--	532 13 83-11	Decal Handle Lift Height Adjust
--	532 41 55-14	Manual Operator's (Euro)
--	532 41 55-15	Manual Operator's (Scan)
--	532 41 55-16	Manual Operator's (Ebloc)
--	532 41 55-17	Manual Operator's (Baltic)
--	<b>532 41 92-59</b>	Manual,

**WHEELS & TIRES**

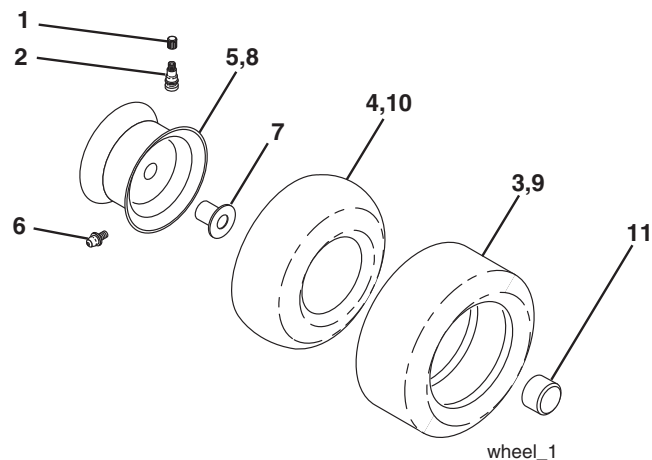

KEY NO.	PART NO.	DESCRIPTION
1	532 05 91-92	Cap Valve Tire
2	532 06 51-39	Stem Valve
3	532 12 41-57	Tire F Ts 15 x 6 0 - 6 Service
4	532 05 99-04	Tube Front (Service Item Only)
5	532 13 83-36	Rim Asm 6" front Silver Service
6	532 12 49-57	Fitting Grease (Front Wheel Only)
7	532 12 49-59	Bearing Flange (Front Wheel Only)
8	532 13 83-37	Rim Asm 8" rear Silver Service
9	532 12 39-69	Tire R Ts 18 x 9 5-8 C Service
10	532 12 49-26	Tube Rear (Service Item Only)
11	532 17 50-39	Cap Axle Blk 1 50 x 1 00
--	532 14 43-34	Sealant, Tire ( 10 oz. Tube)

**NOTE:** All component dimensions given in U.S. inches.  
1 inch = 25.4 mm.

# TRACTOR - - MODEL NO. LT131 (96011026401), PRODUCT NO. 960 11 02-64 SCHEMATIC 38

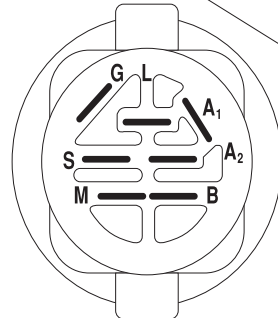
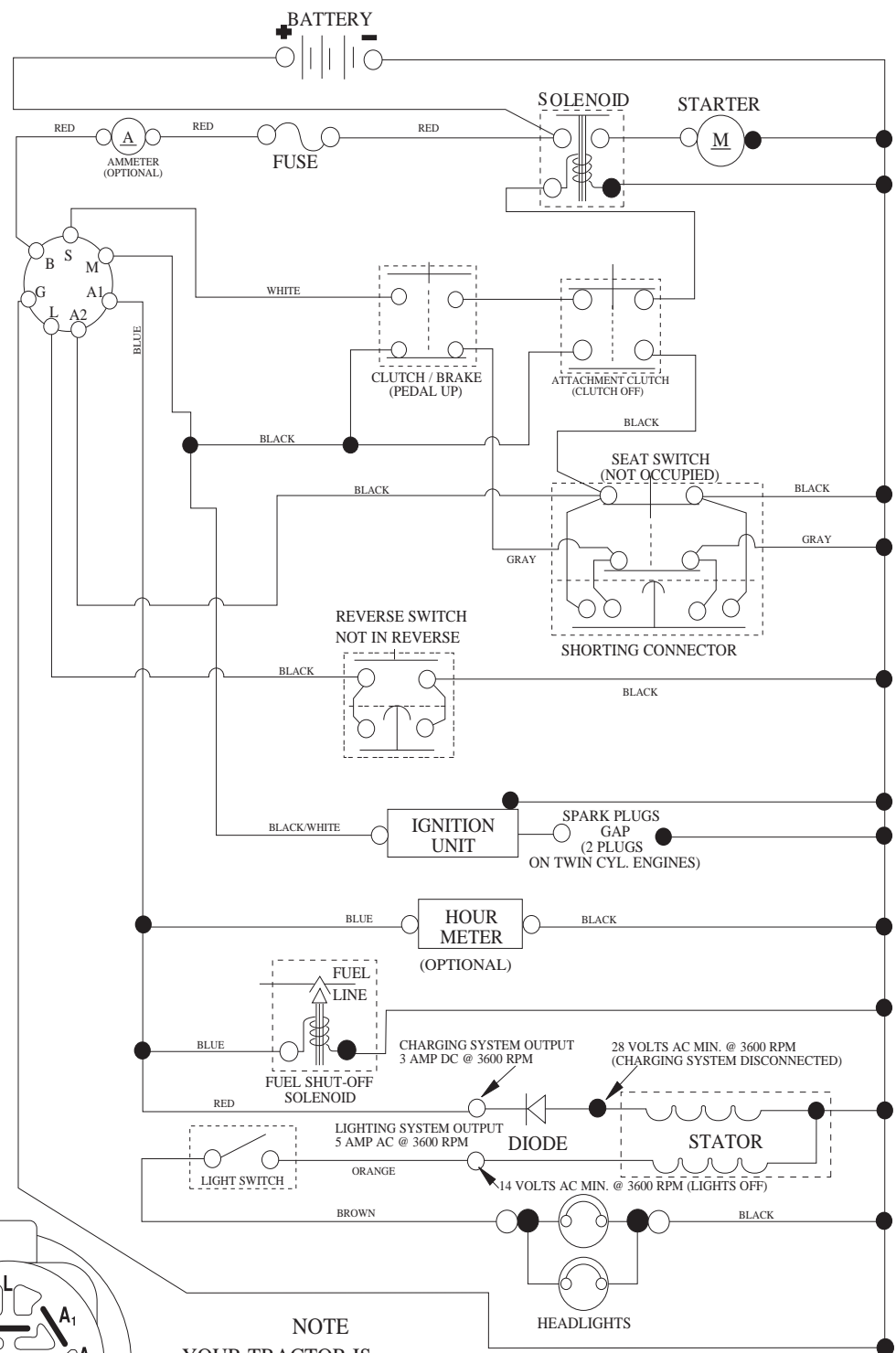

IGNITION SWITCH

POSITION	CIRCUIT "MAKE"
OFF	M+G+A1
RUN/OVERRIDE	B+A1
RUN	B+A1 L+A2
START	B + S + A1

**NOTE**  
YOUR TRACTOR IS EQUIPPED WITH A SPECIAL ALTERNATOR SYSTEM. THE LIGHTS ARE NOT CONNECTED TO THE BATTERY, BUT HAVE THEIR OWN ELECTRICAL SOURCE. BECAUSE OF THIS, THE BRIGHTNESS OF THE LIGHTS WILL CHANGE WITH ENGINE SPEED. AT IDLE THE LIGHTS WILL DIM. AS THE ENGINE IS SPEEDED UP, THE LIGHTS WILL BECOME THEIR BRIGHTEST.



WIRING INSULATED CLIPS  
NOTE: IF WIRING INSULATED CLIPS WERE REMOVED FOR SERVICING OF UNIT, THEY SHOULD BE RE-INSTALLED TO PROPERLY SECURE YOUR WIRING.

TRACTOR - - MODEL NO. LT131 (96011026401), PRODUCT NO. 960 11 02-64  
ELECTRICAL **32**

L02

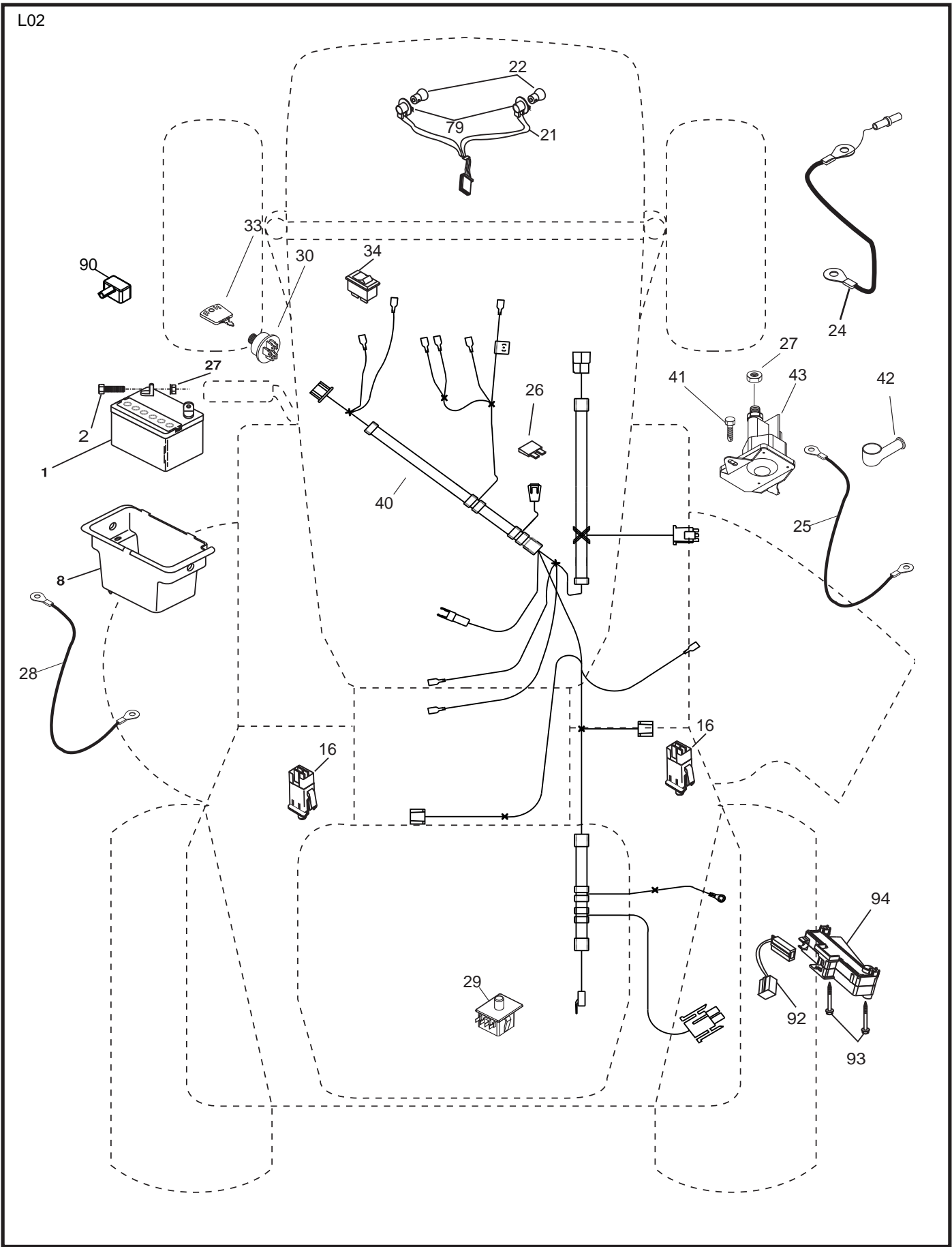

**TRACTOR - - MODEL NO. LT131 (96011026401), PRODUCT NO. 960 11 02-64  
ELECTRICAL 32**

KEY NO.	PART NO.	DESCRIPTION
1	532 16 34-65	Battery
2	874 76 04-12	Bolt Hex Hd 1/4-20 unc x 3/4
8	532 17 66-89	Case Battery Mech Hinge
16	532 17 61-38	Switch Interlock
21	532 17 56-88	Harness Asm Light W/4152j
22	532 00 41-52	Bulb Light #1156
24	532 12 47-80	Cable Battery 6 Ga. 11" red
25	532 14 61-47	Cable Battery 6 Ga. 44" red w/16 wire
26	532 17 51-58	Fuse 20 AMP
27	873 51 04-00	Nut Keps Hex 1/4-20 unc
28	532 12 47-73	Cable Ground 6 Ga. 12" black
29	532 19 27-49	Switch Seat
30	532 19 33-50	Switch Ign
33	532 41 19-35	Key/Chain
34	532 11 07-12	Switch Light
40	532 19 74-28	Harness Ign.
41	871 11 04-08	Bolt Blk Fin Hex 1/4 - 20 x 1/2
42	532 13 15-63	Cover Terminal Red
43	532 19 25-07	Solenoid
79	532 17 52-42	Socket Asm. Bulb Twistlock
90	532 18 04-49	Cover Terminal Battery
92	532 19 66-15	Harness Pigtail
93	532 19 25-40	Screw Plastite 10-24-24 x 2.0
94	532 19 18-34	Module Reverse

**NOTE:** All component dimensions given in U.S. inches.  
1 inch = 25.4 mm.

TRACTOR -- MODEL NO. LT131 (96011026401), PRODUCT NO. 960 11 02-64  
CHASSIS AND ENCLOSURES **39**

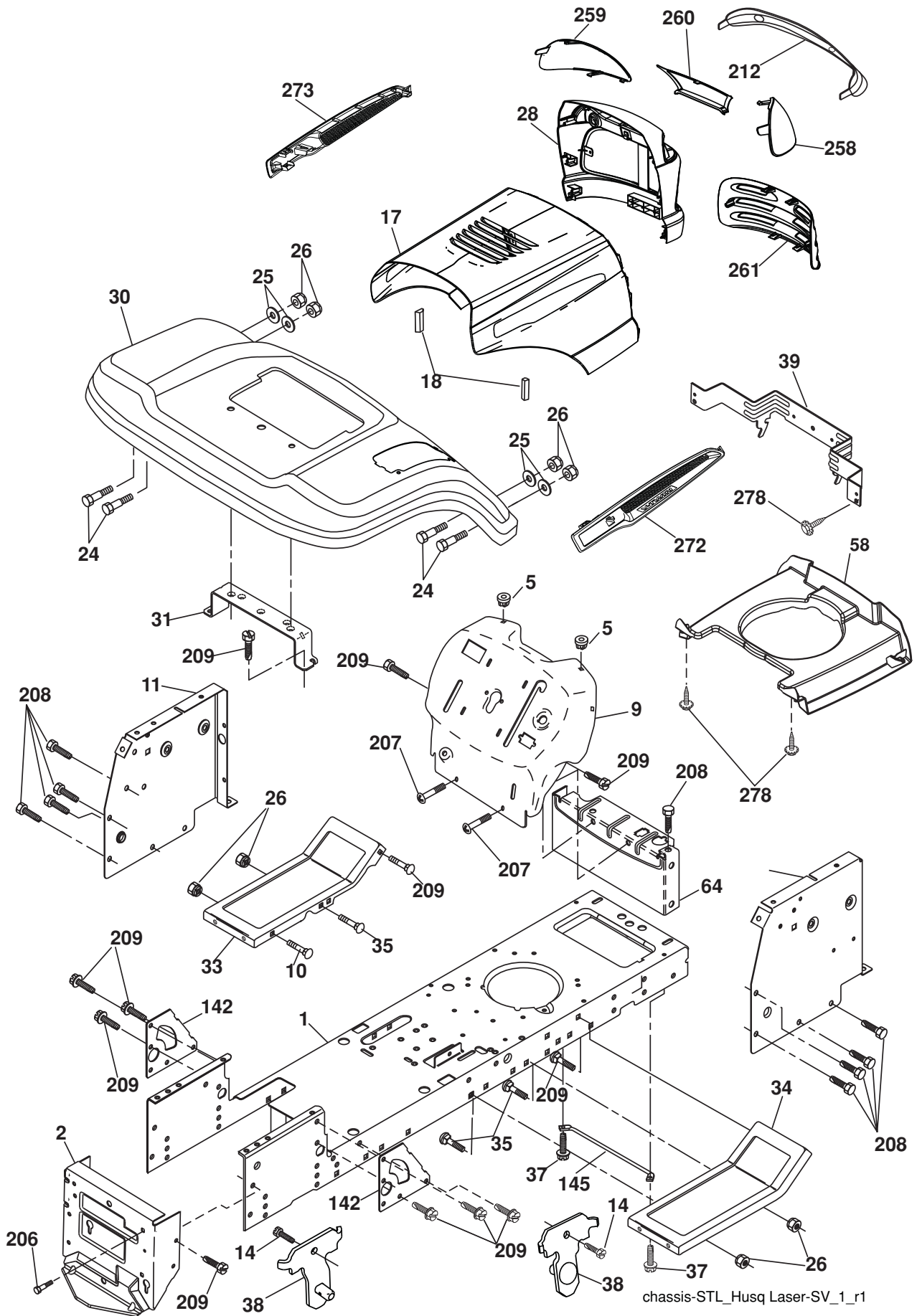

chassis-STL\_Husq Laser-SV\_1\_r1

**TRACTOR - - MODEL NO. LT131 (96011026401), PRODUCT NO. 960 11 02-64  
CHASSIS AND ENCLOSURES **39****

<b>KEY NO.</b>	<b>PART NO.</b>	<b>DESCRIPTION</b>
1	532 17 46-19	Chassis
2	532 17 65-54	Drawbar
5	532 15 52-72	BumperHood/Dash
9	<b>532 41 59-43</b>	Dash STL
10	872 14 06-08	Bolt, Carriage 3/8-16 x 1
11	532 17 49-96	Dashboard, Panel LH
13	<b>532 18 17-19</b>	Dashboard, Panel RH
14	817 49 06-08	Screw Thdrol 3/8-16 x 1/2
17	532 18 88-93	Hood
18	532 18 49-21	BumperHood
24	874 78 06-16	Bolt, Hex Head, Fin. 3/8-16 x 1 Gr. 5
25	819 13 13-12	Washer 13/32 x 13/16 x12 Ga.
26	873 80 06-00	Nut Lock Hex w/Ins. 3/8-16 unc
28	532 18 35-38	Grille (Includes key Nos. 212, 258, 259, 260, 261)
30	532 41 58-33	Fender
31	532 13 66-19	Fender Bracket
33	<b>532 17 97-16</b>	Footrest, LH
34	<b>532 17 97-17</b>	Footrest, RH
35	872 11 06-06	Bolt 3/8-16 X 3/4
37	817 49 05-08	Screw Thdrol 5/16-18 x 1/2
38	532 17 57-10	Bracket Asm. Pivot Mower Rear
39	532 40 78-07	Bracket Pivot Laser
58	532 18 42-70	Duct Air
64	532 15 47-98	Dash Lower
142	532 17 57-02	Plate Reinforcement
145	532 40 91-67	Rod Pivot Chassis/Hood
206	532 17 01-65	Bolt Shoulder 5/16-18 TT
207	817 67 05-08	Screw Thdrol 5/16-18 x 1/2
208	817 67 06-08	Screw Thdrol 3/8-16 x 1/2
209	817 00 06-12	Screw Hexwsh Thdr 3/8-16 x 3/4
212	532 18 35-48	Insert Lens Reflect
258	532 18 52-14	Lens RH
259	532 18 52-13	Lens LH
260	532 18 52-16	Cover Lens
261	532 18 52-12	Insert Grille
272	532 18 88-96	Vent Hood RH
273	532 18 88-95	Vent Hood LH
278	<b>532 41 63-58</b>	Screw #10 x 0.750 BOS Thread
--	532 00 54-79	Button Plug

**NOTE:** All component dimensions given in U.S. inches.  
1 inch = 25.4 mm.





**TRACTOR - - MODEL NO. LT131 (96011026401), PRODUCT NO. 960 11 02-64**  
**DRIVE 40**

KEY NO.	PART NO.	DESCRIPTION	KEY NO.	PART NO.	DESCRIPTION
1	-----	Transaxle Peerless 205-544C	66	532 15 47-78	Keeper Belt Engine Foolproof
2	532 14 66-82	Spring Return Brake T/a Zinc	69	532 14 24-32	Screw Hex 1/4-1/2 unc
3	532 12 36-66	Pulley Transaxle 18" tires	70	532 13 46-83	Guide Belt Mower Drive RH
4	812 00 00-28	Ring Retainer # 5100-62	74	<b>532 13 70-57</b>	Spacer Axle
5	532 12 15-20	Strap Torque 30 Degrees	75	532 12 17-49	Washer 25/32 x 1 1/4 x 16 Ga.
6	817 06 05-12	Screw Thdrol 5/16-18 x 3/4	76	812 00 00-01	E-ring #5133-75
8	532 19 27-06	Rod Shift Fender Adjust Lt	77	532 12 35-83	Key Square 2 0 x 1845/ 1865
10	876 02 04-16	Pin Cotter 1/8 x 1 Cad	78	532 12 17-48	Washer 25/32 x 1-5/8 x 16 Ga.
11	532 10 57-01	Washer Plate Shf 388 Sq Hole	79	532 12 50-96	Key Woodruff #9 3/16 x 3/4
13	874 55 04-12	Bolt 1/4-28 unf Gr. 8 W/Patch	80	<b>532 13 14-86</b>	Arm Shift
14	810 04 04-00	Washer Lock Hvy Helical	81	532 16 55-94	Shaft Asm Cross 18"t
15	874 49 05-44	Bolt Hex 5/16-18 Gr. 5	82	532 16 57-11	Spring Torsion T/a
16	873 80 05-00	Nut Lock Hex w/lns 5/16-18	83	819 17 12-16	Washer 17/32 x 3/4 x 16 Ga.
18	874 78 06-16	Bolt, Fin Hex 3/8-16 unc x 1 Gr. 5	84	<b>532 16 62-28</b>	Link Transaxle
19	873 80 06-00	Nut Lock 3/8-16 unc	85	532 15 03-60	Nut Lock Center 1/4 - 28 FNTHD
21	532 10 69-33	Knob	89	532 19 58-61	Console Shift STLT
22	532 13 08-04	Rod Brake Blk Zinc 26 840	96	532 12 47-88	Retainer Spring 1"
24	873 35 06-00	Nut Hex Jam 3/8-16 unc	112	819 09 12-10	Washer 9/32 x 3/4 x 10 Ga.
25	532 10 68-88	Spring Rod Brake 2 00 Zinc	113	532 12 72-85	Strap Torque LT
26	819 13 13-16	Washer 13/32 x 13/16 x 16 Ga.	116	872 14 06-08	Bolt Rdhd Sq Neck 3/8-16 x 1.0
27	876 02 04-12	Pin Cotter 1/8 x 3/4 Cad	120	873 90 06-00	Nut Lock Flg. 3/8-16 unc
28	532 17 57-65	Rod Brake Parking LT/YT	150	532 17 54-56	Spacer
29	532 07 16-73	Cap Brake Parking Black	151	819 13 32-10	Washer 13/32 x 2 x 10 Ga.
30	532 17 49-73	Bracket Mtg Transaxle	156	532 16 60-02	Washer Srrted 5/16 ID x 1.125
32	874 76 05-12	Bolt Hex Hd 5/16-18 unc x 3/4	158	532 16 55-89	Bracket Shift Mount
34	532 17 55-78	Shaft Asm Pedal Foot	159	532 18 39-00	Hub Shift
35	532 12 01-83	Bearing Nylon Blk 629 Id	161	872 14 04-06	Bolt Rdhd Sqnk 1/4-20 x 3/4 Gr. 5
36	819 21 16-16	Washer 21/32 x 1 x 16 Ga.	162	873 68 04-00	Nut Crownlock 1/4-20 unc
37	532 12 49-63	Pin Roll 3/16 x 1"	163	874 78 04-16	Bolt Hex Fin 1/4-20 unc x 1 Gr. 5
38	532 17 91-14	Pulley Idler Composite	165	532 16 56-23	Bracket Pivot Lever
39	872 11 06-22	Bolt Fin Hex 3/8-16 unc x 2-3/4 Gr. 5	166	817 49 05-10	Screw 5/16-18 x 5/8
41	532 17 55-56	Keeper Belt Idler Flat	168	532 16 54-92	Bolt Shoulder 5/16-18 x .561
47	532 12 77-83	Pulley Idler V Groove Plastic	169	532 16 55-80	Plate Fastening Lt
48	532 15 44-07	Bellcrank Clutch Grnd Driv	170	532 18 74-14	Keeper, Belt T/A
49	532 12 32-05	Retainer Belt Style Spring	197	532 16 96-13	Nyliner Snap-In
50	872 11 06-12	Bolt 3/8-16 x 1-1/2 Gr. 5	198	532 16 95-93	Washer Nyl
51	873 68 06-00	Nut Crownlock 3/8-16 unc	202	872 11 06-14	Bolt Carr. SH 3/8-16 x 1-3/4 Gr. 5
52	873 68 05-00	Nut Crownlock 5/16-18 unc	212	532 14 52-12	Nut, Hex Flange Lock
53	532 19 96-52	Link Clutch	263	817 00 06-12	Screw 3/8-16 x 3/4
55	532 10 57-09	Spring Return Clutch 6 75	268	532 18 24-02	Guard Muffler
56	817 06 06-20	Screw 3/8-16 x 3/4	275	819 13 16-14	Washer 13/32 x 1 x 14 Ga.
57	<b>532 13 82-55</b>	V-Belt Ground Drive 95 .25			
59	532 16 96-91	Keeper Belt Span Ctr			
61	817 12 06-14	Screw 3/8-16 x .875			
62	532 12 48-72	Cover Pedal Round			
63	532 17 54-10	Engine Pulley			
64	532 17 39-37	Bolt Hex			
65	810 04 07-00	Washer Lock Hvy Hlcl Spr 7/16			

**NOTE:** All component dimensions given in U.S. inches  
1 inch = 25.4 mm.

**TRACTOR - - MODEL NO. LT131 (96011026401), PRODUCT NO. 960 11 02-64  
ENGINE 24**

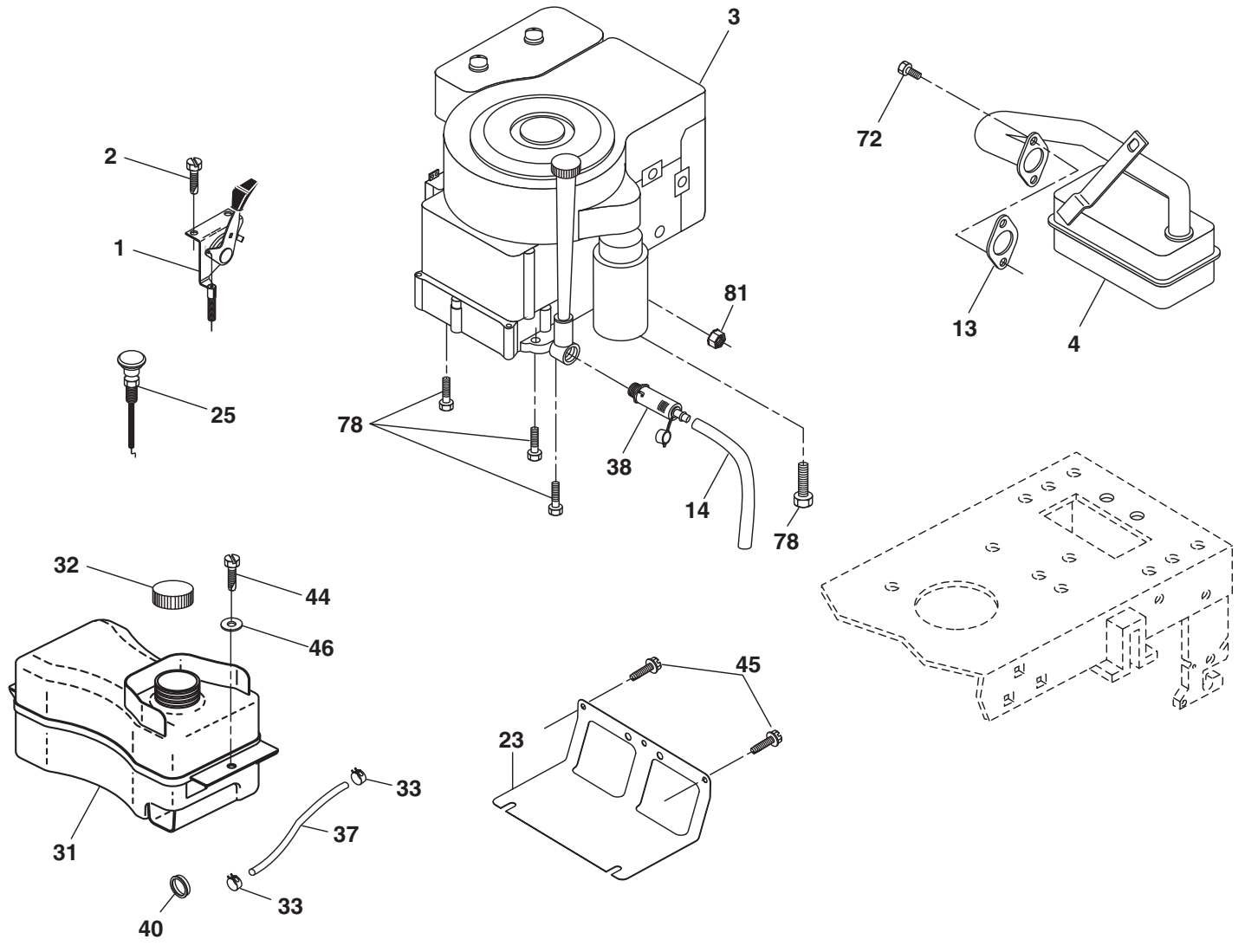

29

**OPTIONAL EQUIPMENT**  
**Spark Arrester**

engine-bs.1cyl\_38

**TRACTOR - - MODEL NO. LT131 (96011026401), PRODUCT NO. 960 11 02-64  
ENGINE 24**

<b>KEY NO.</b>	<b>PART NO.</b>	<b>DESCRIPTION</b>
1	532 17 05-51	Control Th/ch Flag
2	817 72 04-08	Screw Hex Thd Cut 1/4-20 x 1/2
3	-----	Engine B&S Model No. 219807
4	532 17 97-58	Muffler
13	532 16 52-91	Gasket Eng
14	532 14 84-56	Tube Drain Oil Easy
23	532 16 98-37	Shield Brn/Dbr Guard
25	532 19 06-95	Control Choke
29	532 13 71-80	Kit Spark Arrester
31	532 40 75-16	Tank Fuel Front 1.25
32	532 19 77-25	Cap Asm Fuel Top
33	532 12 34-87	Clamp Hose Blk
37	532 13 70-40	Line Fuel 20"
38	532 18 16-54	Plug Oil Drain Easy
40	532 12 40-28	Bushing Snap Nyl Blk Fuel Line
44	817 67 04-12	Screw Hexwsh Thdrol 1/4-20 x 3/4
45	817 00 06-12	Screw Hexwsh Thdrol 3/8-16 x 3/4
46	819 09 14-16	Washer 9/32 x 7/8 x 16 Ga.
72	532 19 23-34	Screw Socket HD 5/16-18 x .75
78	817 06 06-20	Screw 3/8-16 x 1-1/4
81	873 51 04-00	Nut Keps Hex 1/4-20 unc

**NOTE:** All component dimensions given in U.S. inches  
1 inch = 25.4 mm

**Engine Power Rating Information**

The gross power rating for individual gas engine models is labeled in accordance with SAE (Society of Automotive Engineers) code J11940 (Small Engine Power & Torque Rating Procedure), and rating performance has been obtained and corrected in accordance with SAE J1995 (Revision 2002-5). Actual gross engine power will be lower and is affected by, among other things, ambient operating conditions and engine-to-engine variability. Given both the wide array of products on which engines are placed and the variety of environmental issues applicable to operating the equipment, the gas engine will not develop the rated gross power when used in a given piece of power equipment (actual "on-site" or net horsepower). This difference is due to a variety of factors including, but not limited to, accessories (air cleaner, exhaust, charging, cooling, carburetor, fuel pump, etc.), application limitations, ambient operating conditions (temperature, humidity, altitude), and engine-to-engine variability. Due to manufacturing and capacity limitations, Briggs & Stratton may substitute an engine of higher rated power for this Series engine.

TRACTOR - - MODEL NO. LT131 (96011026401), PRODUCT NO. 960 11 02-64  
 STEERING ASSEMBLY **41**

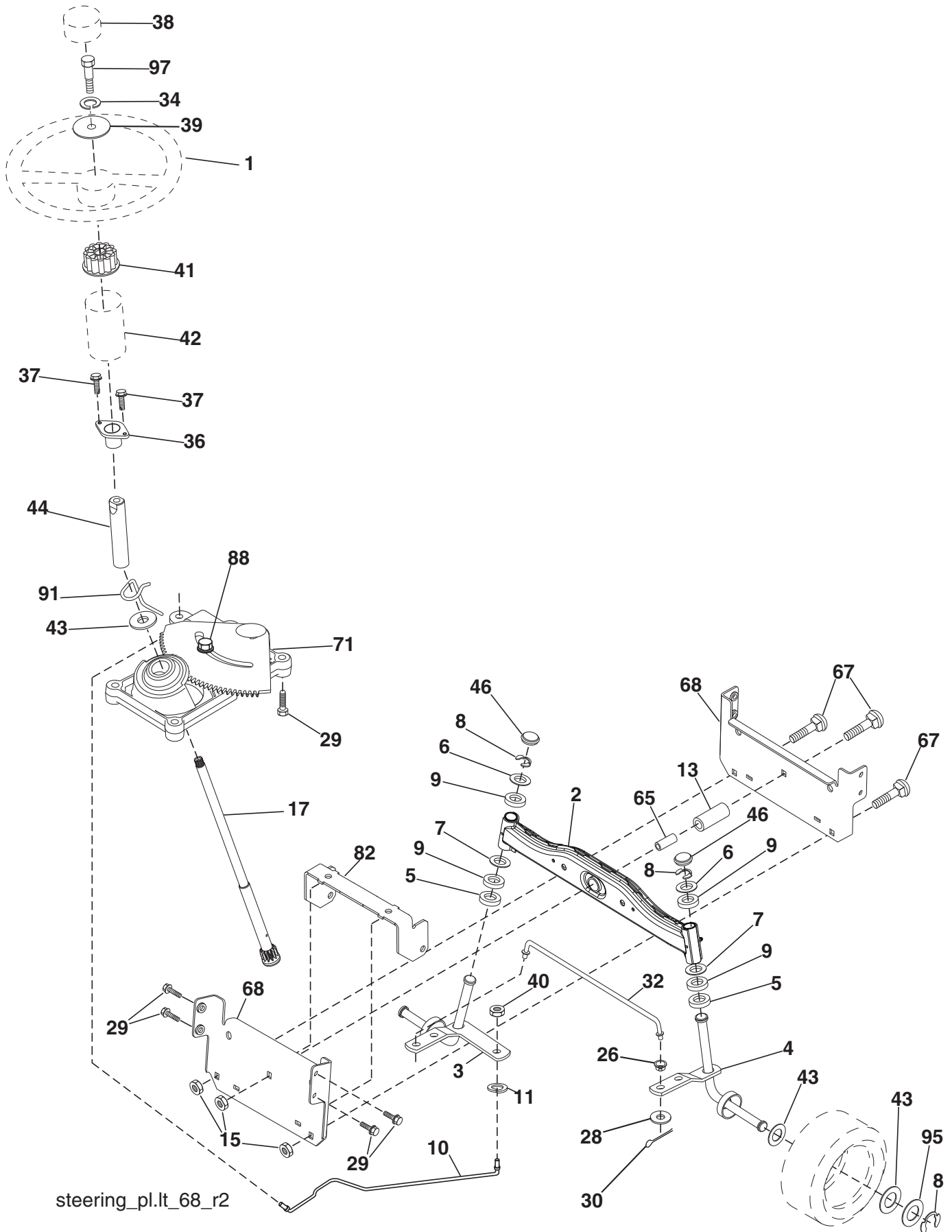

steering\_pl.lt\_68\_r2

**TRACTOR - - MODEL NO. LT131 (96011026401), PRODUCT NO. 960 11 02-64**  
**STEERING ASSEMBLY 41**

<b>KEY NO.</b>	<b>PART NO.</b>	<b>DESCRIPTION</b>
1	532 18 67-80	Wheel Steering Opp. Sears Blk
2	<b>532 41 81-68</b>	Axle Asm
3	532 16 98-40	Spindle Asm LH
4	532 16 98-39	Spindle Asm RH
5	532 12 49-31	Bearing Race Thrust Hardened
6	532 12 17-48	Washer 25/32 x 1-5/8 x 16 Ga.
7	819 27 20-16	Washer 27/32 x 1-1/4 x 16 Ga.
8	812 00 00-29	Ring Klip #t5304-75
9	532 12 49-37	Bearing Col Strg Blk
10	532 17 51-21	Link Drag
11	810 04 06-00	Washer Lock Hvy Hlcl Spr 3/8
13	532 13 65-18	Spacer Brace Axle
15	532 14 52-12	Nut Hexflange Lock
17	532 19 07-53	Shaft Asm Strg
26	532 12 68-47	Bushing Link Drag Blk LR
28	819 13 14-16	Washer 13/32 x 7/8 x 16 Ga.
29	817 00 06-12	Screw 3/8-16 x .75
30	876 02 04-12	Pin Cotter 1/8 x 3/4 Cad
32	532 19 27-57	Rod Tie Wire Form 19 75 Mech
34	810 04 05-00	Washer Lock Hvy Hlcl Spr. 5/16
36	532 15 50-99	Bushing Strg Nat .623/.618ld
37	532 15 29-27	Screw TT #10-32 x 5 x 3/8 Flange
38	532 19 29-16	Cap Wheel Steer P/L
39	819 11 38-12	Washer 11/32 x 2-3/8
40	873 54 06-00	Nut Crownlock 3/8-24
41	532 18 67-37	Adaptor Wheel Strg
42	532 16 96-33	Boot Shaft Steering
43	532 12 17-49	Washer 25/32 x 1 1/4 x 16 Ga.
44	532 19 07-52	Extension Steering
46	532 12 12-32	Cap Spindle Fr Top Blk
65	<b>532 41 47-36</b>	Spacer Brace Axle
67	872 11 06-18	Bolt RDHD SQ 3/8-16 unc x 2-1/4
68	532 16 98-27	Brace Axle
71	532 17 51-46	Steering Asm
82	532 19 99-78	Bracket Susp. Chassis Front
88	532 17 51-18	Bolt Shoulder 7/16-20
91	532 17 55-53	Cup Steering
95	532 18 89-67	Washer Hardened
97	874 78 05-64	Bolt 5/16-18 unc x 4" L Gr. 5

**NOTE:** All component dimensions given in U.S. inches.  
1 inch = 25.4 mm.



**TRACTOR - - MODEL NO. LT131 (96011026401), PRODUCT NO. 960 11 02-64**  
**MOWER DECK 44**

KEY NO.	PART NO.	DESCRIPTION	KEY NO.	PART NO.	DESCRIPTION
1	532 19 25-56	Mower Housing Assembly	72	532 19 32-16	Spring Brake Return
2	872 14 05-06	Bolt Carriage 5/16-18 x 3/4	89	819 13 13-11	Washer 13/32 x 13/16 x 11 Ga.
3	532 13 80-17	Bracket Asm Fr. Sway Bar	107	532 13 35-02	Spacer Retainer
4	532 19 25-68	Bracket Deck Sway Bar 38"/42"	108	532 13 35-03	Stiffener, Idler Arm
5	532 12 46-70	Retainer Spring	122	532 41 01-89	Rod, Brake LH
6	532 17 80-24	Bar Sway Deck	123	532 41 01-90	Rod, Brake RH
7	873 80 05-00	Nut Lock Hex w/Ins. 5/16-18 unc	144	532 19 34-14	Keeper Belt Idler Tension
8	532 19 30-03	Bolt 3/8-24 x 1.25 Gr. 8	148	532 16 90-22	Spring Return Idler
11	532 19 39-57	Blade Mower 38" 3 N 1 Premium	149	532 16 58-98	Retainer Spring Yellow
13	532 19 28-72	Shaft Assembly, Mandrel, Vented	150	819 09 12-10	Washer 9/32 x 3/4 x 10 Ga.
14	532 18 72-81	Housing, Mandrel, Vented	152	532 19 32-35	Clutch Cable 38"/46"
15	532 11 04-85	Bearing, Ball, Mandrel	158	817 72 04-08	Screw Hex Thd Cut 1/4-20 x 1/2
18	872 14 05-05	Bolt Rdhd Sqnk 5/16-18 x 5/8	185	532 18 82-34	Head Asm Cable Clutch
19	532 13 28-27	Bolt, Shoulder	186	817 49 06-44	Screw Hex Wsh Thdrol 3/8-16 x 2-3/4
20	532 40 00-95	Baffle Vortex Front	187	532 19 34-12	Keeper Belt
21	873 68 05-00	Nut	188	532 16 58-91	Bolt Carriage Idler
23	532 19 25-57	Bracket, Mower Deflector	189	532 19 25-59	Stand, Brake
24	532 10 53-04	Cap, Sleeve	190	532 19 25-60	Arm, Brake
25	532 19 70-26	Spring, Torsion, Deflector	191	532 19 25-61	Spacer, Brake
26	532 11 04-52	Nut, Push	193	532 19 34-13	Keeper Belt Rh Mandrel
27	532 40 14-72	Shield, Deflector	194	532 19 41-05	Guard Brake
29	532 13 14-91	Rod, Hinge	195	819 13 32-10	Washer
30	532 17 39-84	Screw Thdrol.	214	<b>532 19 37-82</b>	Bolt/Washer Asm 5/16-18
31	532 18 76-90	Washer, Spacer	--	532 19 25-58	Brake Assembly (Includes Stand, Arm and Guard Components)
32	532 15 35-32	Pulley, Mandrel	--	532 19 28-70	Mandrel Assembly (Includes housing, shaft assembly, and bearing only - pulley/nut/washer and blade bolt/washers not in- cluded)
33	532 40 02-34	Nut, Flange Lock Top	--	532 19 36-46	Replacement Mower, Complete
36	532 13 14-94	Pulley, Idler, Flat			
37	532 19 31-98	Pulley Idler Flat			
40	873 68 06-00	Nut, Crownlock 3/8-16 unc			
45	532 12 47-88	Retainer Spring			
55	532 13 38-40	Idler Arm Assembly			
56	532 16 57-23	Spacer, Retainer			
67	532 10 69-32	Knob			
68	532 19 32-14	V-Belt			

**NOTE:** All component dimensions given in U.S. inches.  
1 inch = 25.4 mm.





**TRACTOR - - MODEL NO. LT131 (96011026401), PRODUCT NO. 960 11 02-64  
MOWER LIFT 45**

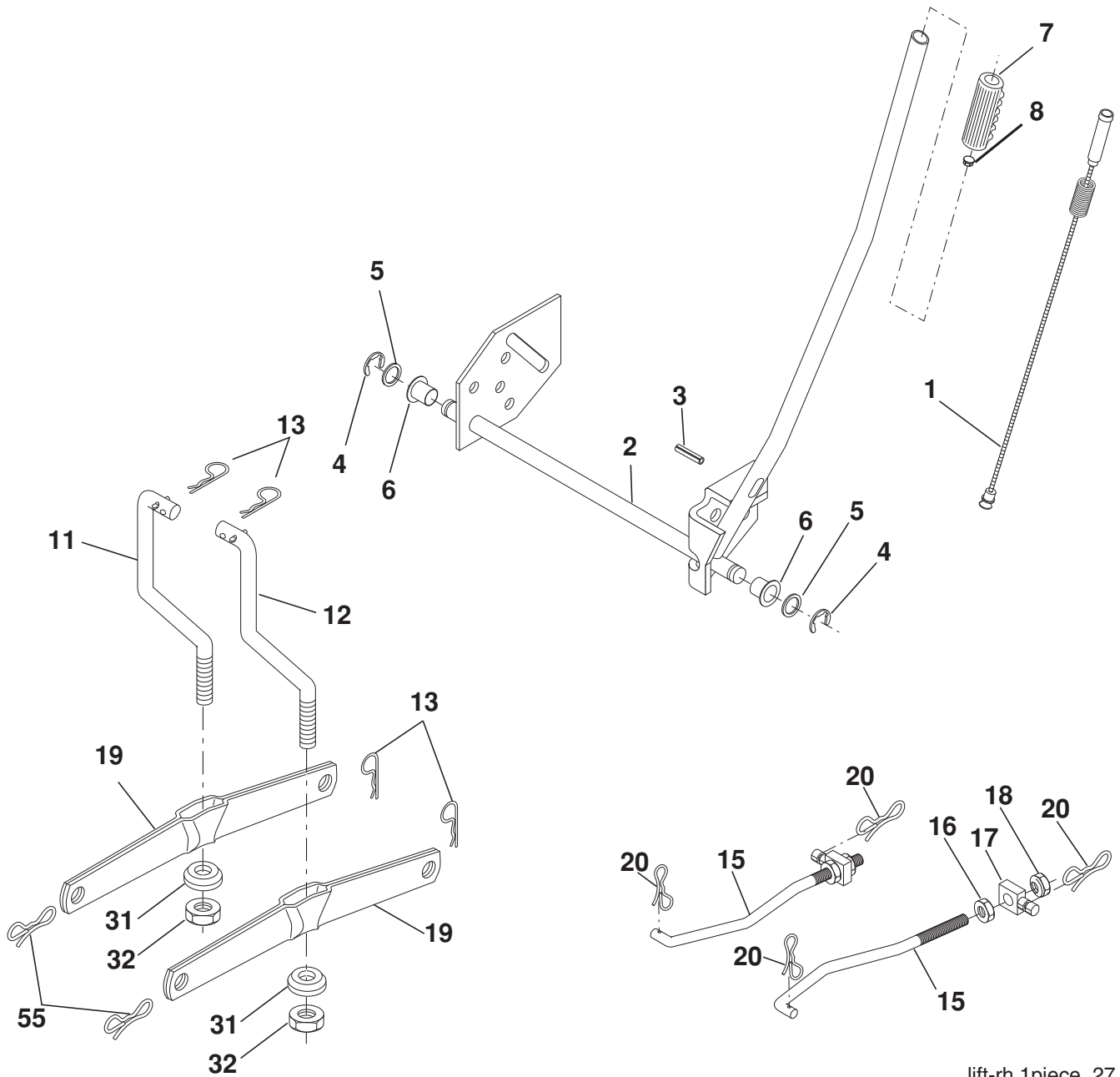

lift-rh.1piece\_27

KEY NO.	PART NO.	DESCRIPTION
1	532 15 94-60	Wire Asm Inner W/Plunger
2	532 15 94-71	Shaft Asm Lift
3	532 10 57-67	Pin Groove
4	812 00 00-02	E Ring #5133-62
5	819 21 16-21	Washer PLTD 21/32 x 1 x 21Ga
6	532 12 01-83	Bearing Nylon Blk 629 Id
7	532 10 94-13	Grip Handle Bicycle Matte Blk
8	532 12 45-26	Button Plunger Black
11	532 13 98-65	Link Lift LH
12	532 13 98-66	Link Lift RH
13	532 12 46-70	Retainer Spring
15	532 17 32-88	Link Front

KEY NO.	PART NO.	DESCRIPTION
16	873 35 08-00	Nut Jam Hex 1/2-13 unc
17	532 17 56-89	Trunnion
18	873 80 08-00	Nut Lock W/Wsh 1/2-13 unc
19	532 13 98-68	Arm Suspension Rear
20	532 19 42-09	Pin Cotter 7/16 Bow Tie Lock
31	532 16 98-65	Bearing Pvt Lift
32	873 54 06-00	Nut Crownlock 3/8-24
55	532 19 42-08	Pin Cotter 5/16 Bow Tie Lock

**NOTE:** All component dimensions given in U.S. inches  
1 inch = 25.4 mm