

LT151

Spare parts
Ersatzteile
Pièces détachées
Reserve onderdelen
Repuestos
Reservdelar

ILLUSTRATED PARTS LIST

MODEL NO. 96041001706
CUSTOMER CATALOG NO. LT151
PRODUCT NO. 960 41 00-17

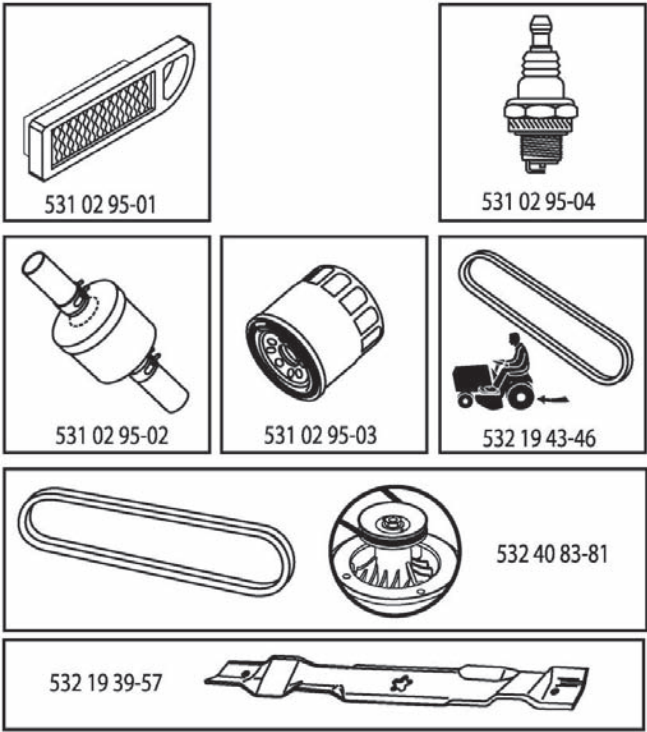

408771

**TRACTOR - - MODEL NUMBER LT151 (96041001706), PRODUCT NO. 960 41 00-17
DECALS**

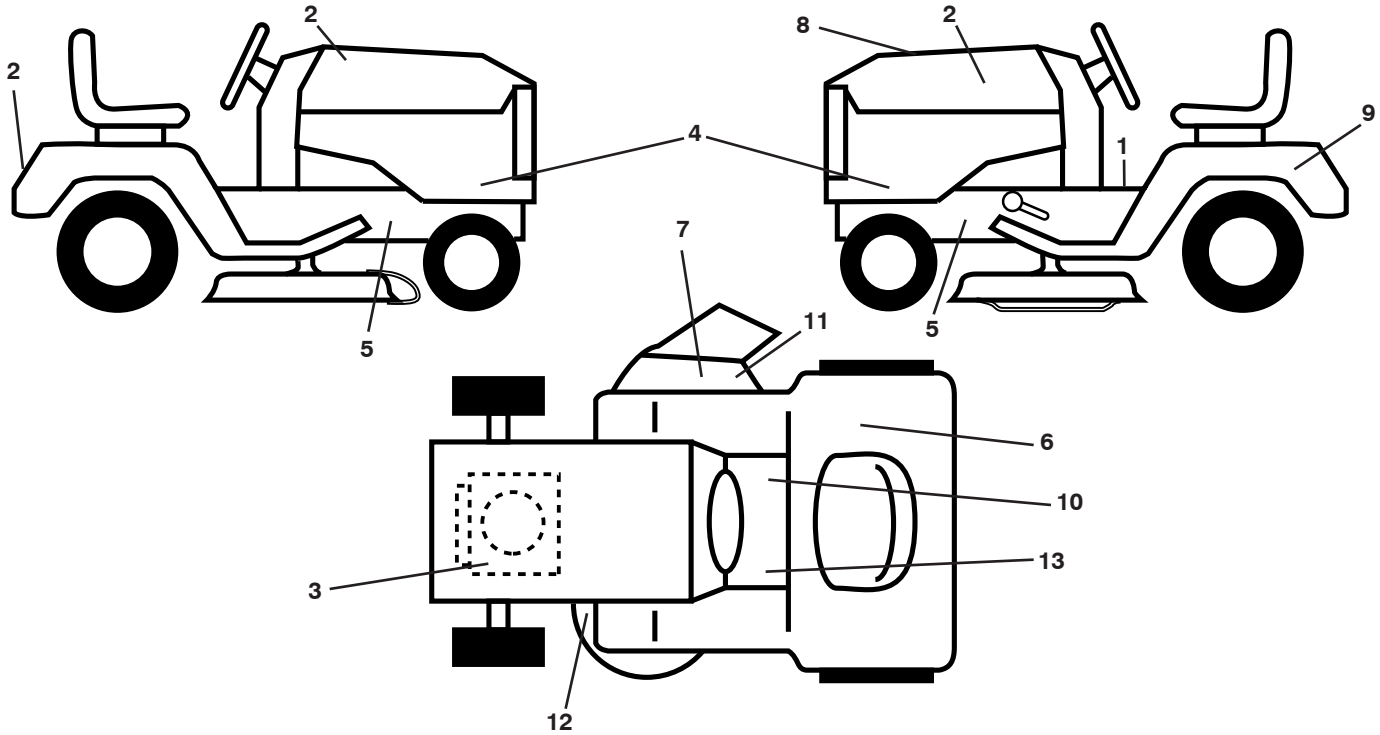

KEY NO.	PART NO.	DESCRIPTION
1	532 40 03-89	Decal, Operators
2	532 40 28-32	Decal, Hood/Fender
3	532 19 68-41	Decal, Warning Eng. Symbols
4	532 40 85-96	Decal, Hood Panel
5	532 15 97-36	Decal, Chassis Hot Muffler
6	532 18 04-32	Decal, Fender 100 DB/CE
7	532 18 21-66	Decal, Cutfinger CE
8	532 40 87-71	Decal, Rpl. Kohl 15
9	532 14 50-05	Decal, Battery Dan./Poi.
10	532 14 08-37	Decal, Saddle Brake Parking

KEY NO.	PART NO.	DESCRIPTION
11	532 19 63-57	Decal, Warning
12	532 19 43-02	Decal, Mower V-Belt Schematic
13	532 15 97-37	Decal, Brake/Clutch Symbol
--	532 41 08-05	Pad, Footrest, LH
--	532 41 10-56	Pad, Footrest, RH
--	532 16 25-98	Decal, Drawbar Load Limit
--	532 40 78-08	Manual Oper. Euro
--	532 40 78-09	Manual Oper. Scand
--	532 40 78-10	Manual Oper. E-Bloc
--	532 40 78-11	Manual Oper. Baltic

WHEELS AND TIRES

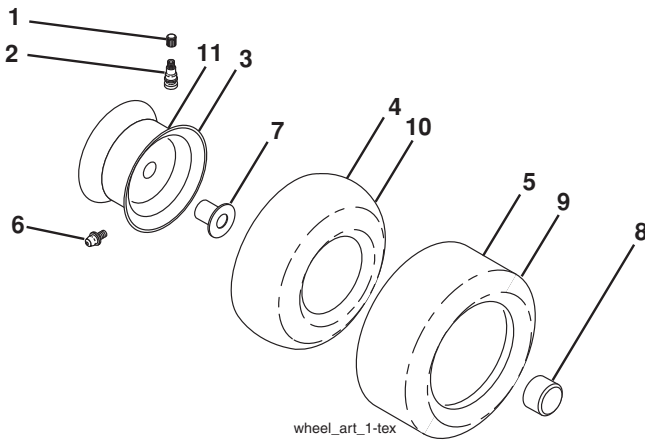

KEY NO.	PART NO.	DESCRIPTION
1	532 05 91-92	Cap Valve Tire
2	532 06 51-39	Stem Valve
3	532 10 62-22	Tire F T 15 x 6 0 - 6
4	532 05 99-04	Tube Front (Service Item Only)
5	532 13 83-36	Rim Asm. 6" Front
6	532 12 49-57	Fitting Grease (Front Wheel Only)
7	532 12 49-59	Bearing Flange (Front Wheel Only)
8	532 17 50-39	Cap Axle Blk. 1 50 x 1 00
9	532 10 62-68	Tire R 18 x 9.5-8 Turf Saver
--	532 42 05-31	Tire R 18 x 9.5-8 Turf Saver LT
10	532 12 49-26	Tube Rear (Service Item Only)
11	532 13 83-37	Rim Asm. 8" Rear
--	532 14 43-34	Sealant, Tire (10 oz. Tube)

NOTE: All component dimensions given in U.S. inches
1 inch = 25.4 mm

TRACTOR - - MODEL NUMBER LT151 (96041001706), PRODUCT NO. 960 41 00-17 SCHEMATIC

SCH10

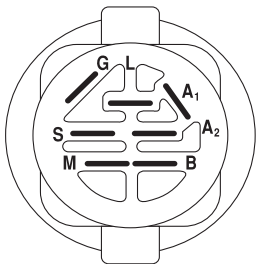
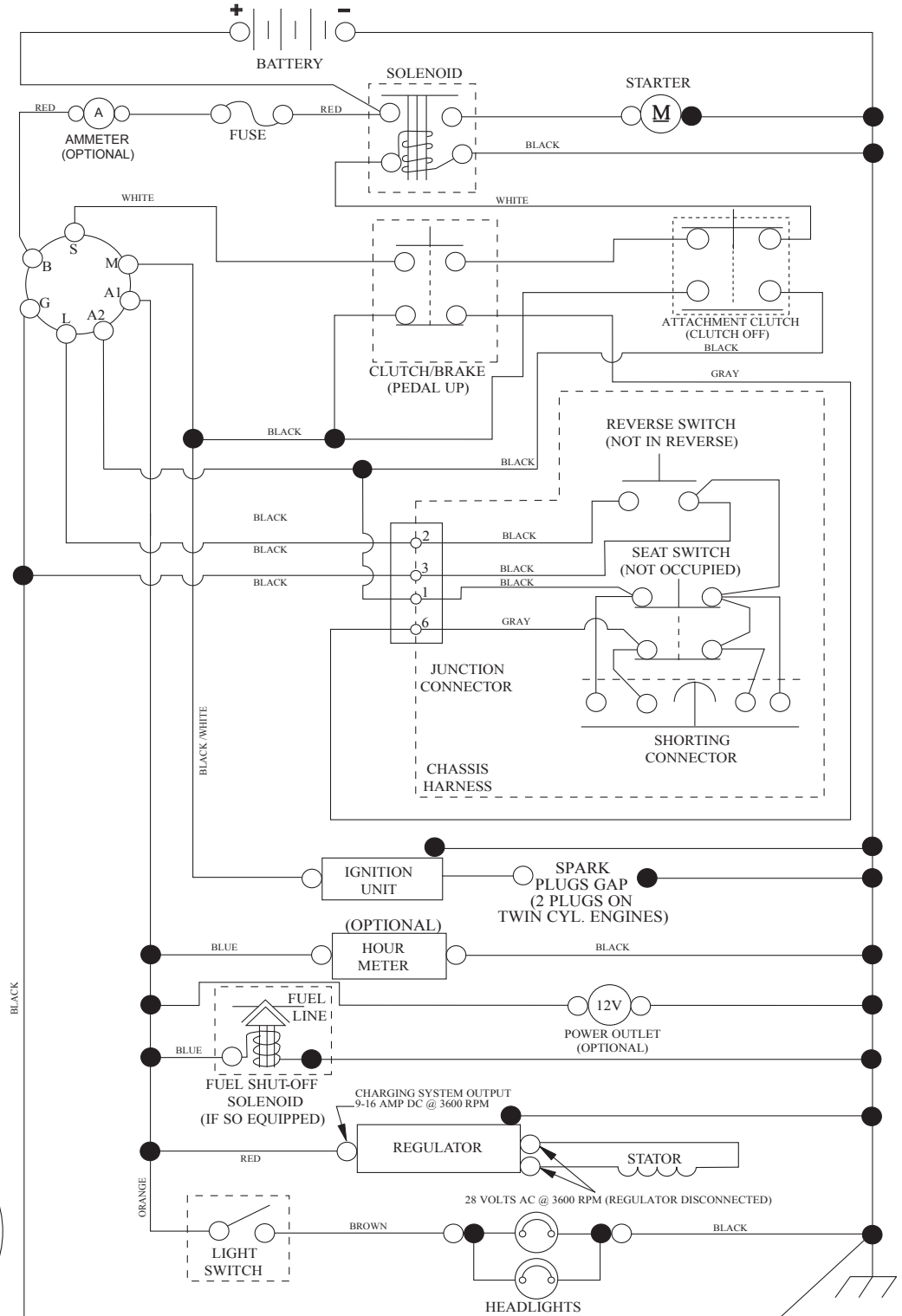

IGNITION SWITCH

POSITION	CIRCUIT	"MAKE"
OFF	M+G+A1	
RUN/OVERRIDE	B+A1	
RUN	B+A1	L+A2
START	B + S + A1	

03107

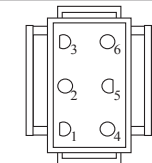

CHASSIS HARNESS CONNECTOR (MATING SIDE)

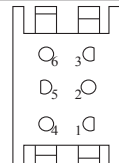

DASH HARNESS CONNECTOR (MATING SIDE)

WIRING INSULATED CLIPS
NOTE: IF WIRING INSULATED CLIPS WERE REMOVED FOR SERVICING OF UNIT, THEY SHOULD BE RE-INSTALLED TO PROPERLY SECURE YOUR WIRING.

NON-REMOVABLE CONNECTIONS

REMOVABLE CONNECTIONS

**TRACTOR - - MODEL NUMBER LT151 (96041001706), PRODUCT NO. 960 41 00-17
ELECTRICAL**

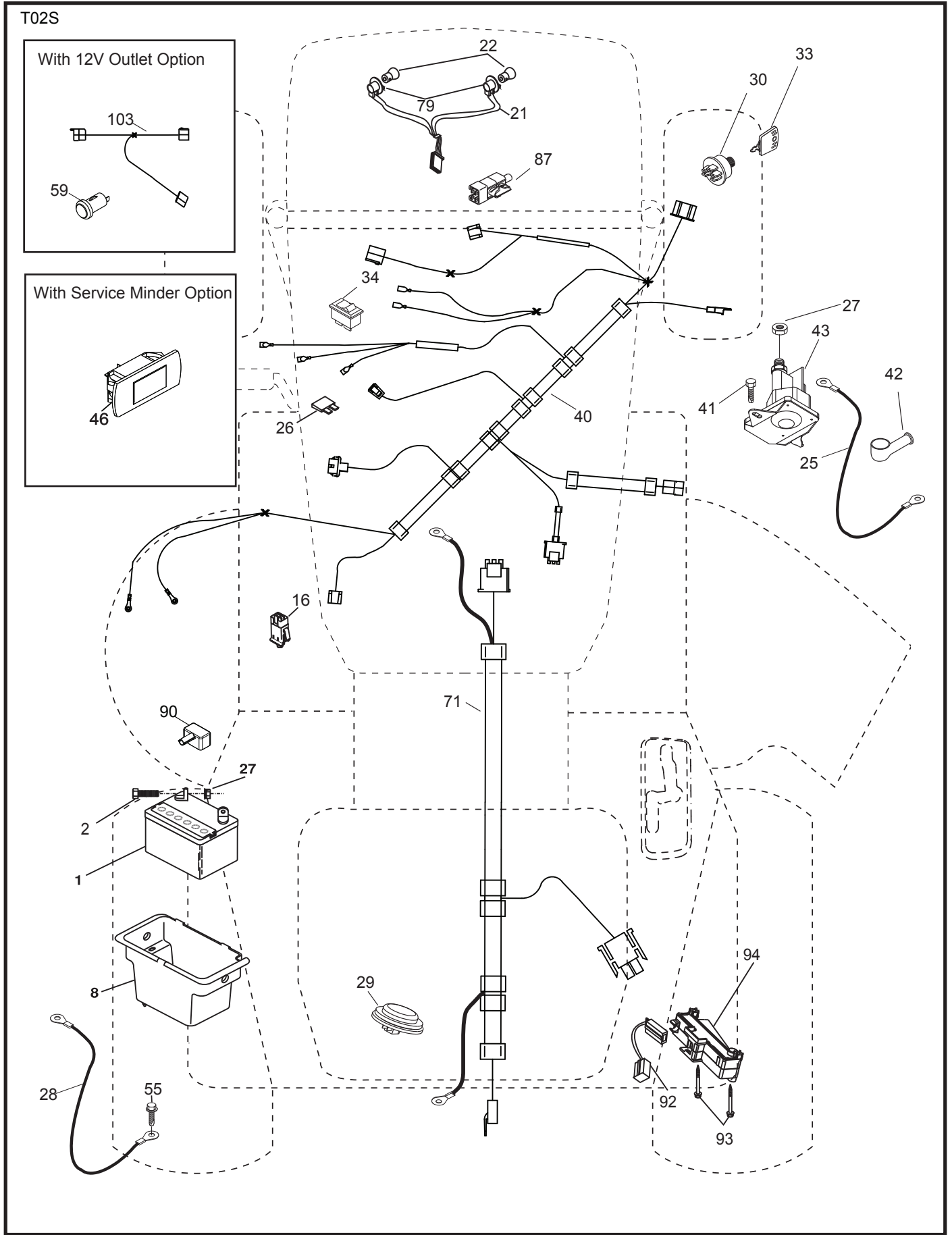

**TRACTOR - - MODEL NUMBER LT151 (96041001706), PRODUCT NO. 960 41 00-17
ELECTRICAL**

KEY NO.	PART NO.	DESCRIPTION
1	532 16 34-65	Battery
2	874 76 04-12	Bolt Hex Head 1/4-20 x 3/4
8	532 19 32-28	Box Battery
16	532 17 61-38	Switch Interlock Push-In
21	532 40 02-52	Harness Socket Light w/4152J
22	532 00 41-52	Bulb Light
25	532 41 28-94	Cable Starter
26	532 17 51-58	Fuse
27	873 51 04-00	Nut Keps Hex 1/4-20 unc
28	532 19 88-85	Cable, Ground
29	532 40 15-45	Switch, Seat
30	532 19 33-50	Switch, Ign.
33	532 41 19-35	Key/Chain
34	532 11 07-12	Switch Light/Reset
40	532 40 10-98	Harness Ign. Dash
41	817 72 04-08	Screw Thd. Cut 1/4-20 x 1/2
42	532 13 15-63	Cover, Terminal
43	532 19 25-07	Solenoid
55	817 06 05-12	Screw Thdrol. 5/16-18 x 3/4 TYTT
71	532 40 04-49	Harness Chassis
79	532 17 52-42	Socket Asm. Bulb Twistlock
87	532 19 78-02	Switch Interlock Clutch Cable
90	532 40 07-25	Cover Terminal
92	532 19 66-15	Harness Pigtail Reverse Switch
93	532 19 25-40	Screw Plastite 10-14 x 2.0
94	532 19 18-34	Module Reverse ROS

NOTE: All component dimensions given in U.S. inches
1 inch = 25.4 mm

**TRACTOR - - MODEL NUMBER LT151 (96041001706), PRODUCT NO. 960 41 00-17
CHASSIS**

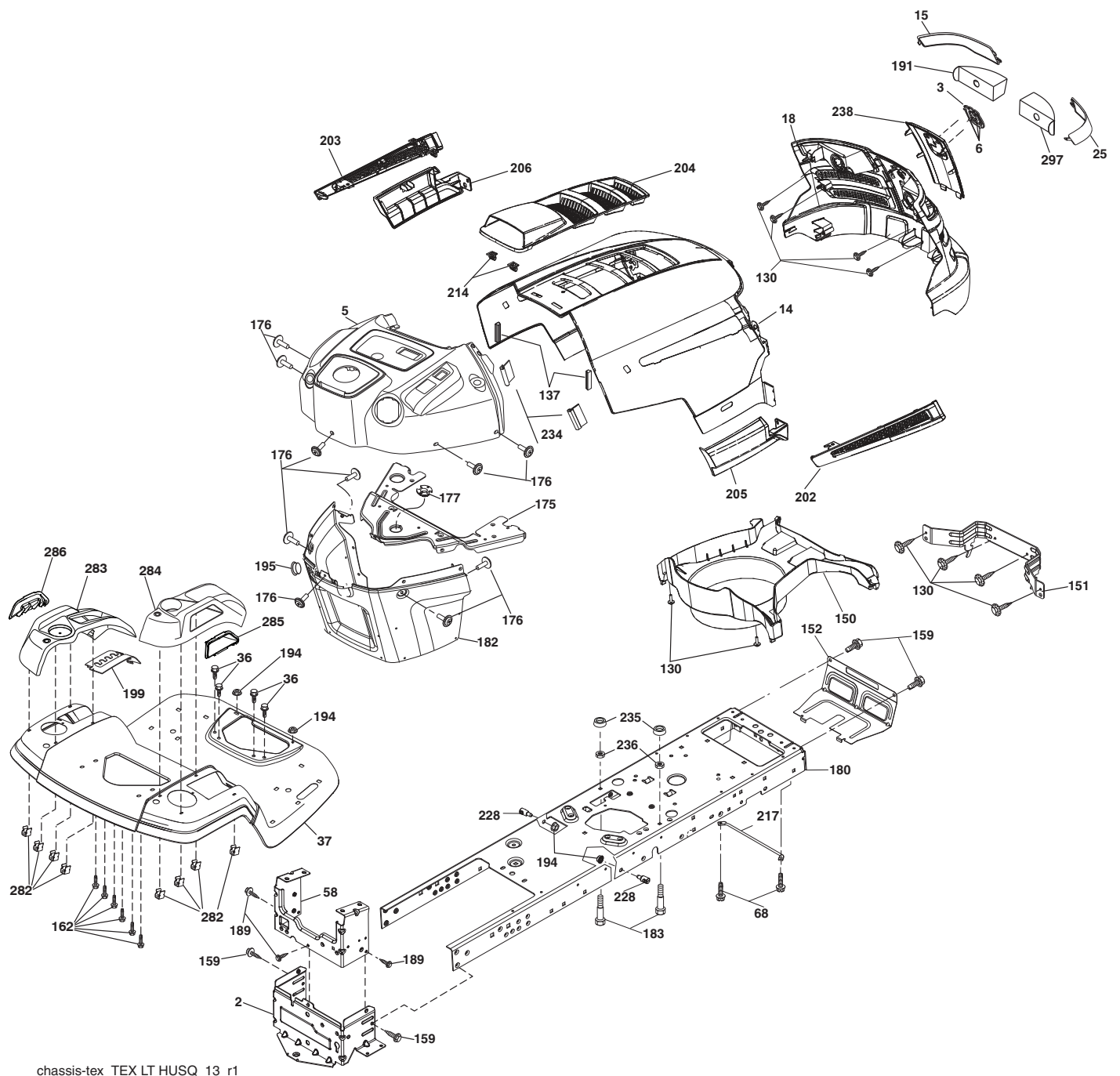

chassis-tex_TEX LT HUSQ_13_r1

**TRACTOR - - MODEL NUMBER LT151 (96041001706), PRODUCT NO. 960 41 00-17
CHASSIS**

KEY NO.	PART NO.	DESCRIPTION
2	532 41 22-82	Drawbar
3	532 40 50-12	Logo
5	532 40 75-92	Dash
6	532 40 48-83	Clip Tinnerman
14	532 41 10-73	Hood
15	532 41 10-79	Lens LH
18	532 40 66-67	Grille
25	532 41 10-78	Lens RH
36	817 06 05-12	Screw 5/16-18 x 3/4
37	532 41 63-07	Fender
58	532 41 22-80	Drawbar Upper
68	817 49 05-08	Screw Thdrol. 5/16-18 x 1/2
130	532 41 63-58	Screw #10 x .750 BOS Thread
137	532 40 75-90	Bumper Dash
150	532 40 75-37	Air Duct
151	532 40 78-07	Bracket Pivot
152	532 19 43-29	Shield Browning
159	817 00 06-12	Screw 3/8-16 x 3/4
162	532 14 24-32	Screw Hex Wsh. Hi-Lo 1/4 x 1/2 unc
175	532 19 94-72	Crossmember
176	532 40 07-76	Screw 10-24 x 5/8
177	532 19 52-28	Bushing Steering
180	532 19 42-60	Chassis
182	532 40 71-76	Dash Lower
183	874 78 05-20	Bolt 5/16-18 unc x 1-1/4
189	817 00 05-12	Screw 5/16-18 x 3/4
191	532 40 66-65	Insert Reflective
194	873 90 05-00	Nut Lock Hex Flange 5/16-18
195	532 41 11-15	Plug Dash
199	532 41 34-85	Plate Deck Lift
202	532 41 10-74	Vent Side Hood RH
203	532 41 10-75	Vent Side Hood LH
204	532 41 11-16	Vent Top Hood
205	532 41 10-76	Skirt Side RH
206	532 41 10-77	Skirt Side LH
214	532 19 91-45	Clip Retainer
217	532 40 91-67	Rod Pivot Hood
228	532 19 51-61	Stud Fastener
234	532 40 47-42	Bumper Hood
235	532 40 61-29	Spacer Fender
236	873 93 05 00	Nut Center Lock 5/16-18 unc
238	532 41 11-19	Trim
282	532 41 41-10	Clip Retainer
283	532 41 63-16	Console Deck Lift
284	532 41 63-14	Console Shift
285	532 41 63-15	Console Insrt. RH
286	532 41 63-17	Console Insrt. LH
287	817 60 04-06	Screw Hex Washhead. 1/4-20 x 3/8

NOTE: All component dimensions given in U.S. inches
1 inch = 25.4 mm

**TRACTOR - - MODEL NUMBER LT151 (96041001706), PRODUCT NO. 960 41 00-17
DRIVE**

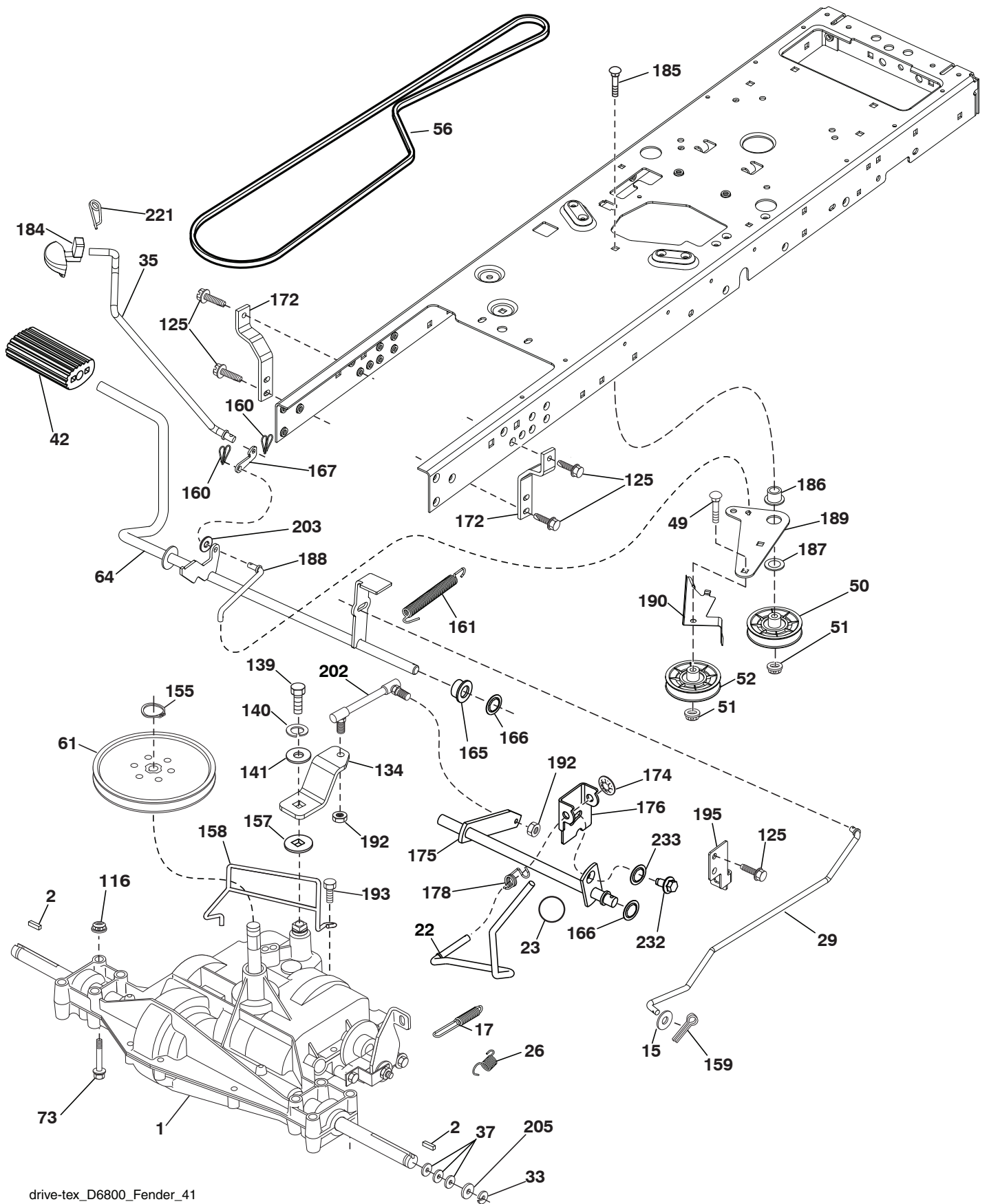

drive-tex_D6800_Fender_41

TRACTOR - - MODEL NUMBER LT151 (96041001706), PRODUCT NO. 960 41 00-17 DRIVE

KEY NO.	PART NO.	DESCRIPTION	KEY NO.	PART NO.	DESCRIPTION
1	----	Transaxle, Dana D6800-1 (Order Parts from Transaxle Manufacturer)	165	532 19 62-12	Bushing Shaft Brake Hand Control
2	532 12 35-83	Key Square	166	532 19 72-90	Nut Push .625
15	819 13 13-16	Washer 13/32 x 13/16 x 16 Ga.	167	532 40 52-57	Latch Brake Parking
17	532 19 72-97	Spring, Brake	172	532 19 76-57	Strap Torque LH
22	532 19 76-60	Rod Shift	174	532 19 72-89	Nut Push
23	532 12 12-74	Knob Duckhead 1/2-13	175	532 19 89-81	Shaft Asm. Shift
26	532 19 74-55	Spring Brake Return	176	532 19 62-14	Arm Clevis Rod Shift
29	532 19 72-67	Rod, Brake	178	532 19 74-56	Spring Shift
33	812 00 00-01	Ring E	184	532 40 97-47	Knob
35	532 40 10-31	Rod, Brake, Park	185	872 11 06-20	Bolt
37	532 12 17-49	Washer 25/32 x 1-1/4 x 16 Ga.	186	532 19 43-21	Spacer Retainer
42	532 12 48-72	Cover, Foot Pedal	187	819 13 32-10	Washer
49	872 11 06-14	Bolt	188	532 19 43-23	Link Clutch Ground Drive
50	532 19 43-27	Pulley Idler Flat	189	532 19 43-17	Bellcrank Ground Drive
51	873 90 06-00	Lock Nut 3/8-16	190	532 19 43-18	Keeper Bellcrank Ground Drive
52	532 19 43-26	Idler V-Groove 910" Offset	192	532 15 03-60	Nut Lock Center 1/4-28 Fnthd.
56	532 19 43-46	V-Belt, Drive	193	817 06 05-12	Screw 5/16-18 x 3/4
61	532 41 56-25	Pulley Transaxle	195	532 19 73-32	Bracket Brake Rod
64	532 19 62-00	Shaft Asm. Pedal Brake Control	202	532 19 95-89	Link Transaxle
73	874 49 05-44	Bolt Hex Flghd. 5/16-18 Gr. 5	203	819 11 11-16	Washer 11/32 x 11/16 x 16 Ga.
116	873 90 05-00	Nut Lock Hex Flange 5/16-18	205	532 12 17-48	Washer 25/32 x 1-5/8 16 Ga.
125	817 00 05-12	Screw 5/16-18 x 3/4	221	532 40 31-87	Retainer Spring Clip Handle
134	532 40 24-30	Asm. Shift	232	874 78 07-16	Bolt Fin. Hex 7/16-14 x 1 Gr. 5
139	874 55 04-12	Bolt 1/4-28 unf Gr. 8 w/Patch	233	532 40 52-96	Washer Serrated
140	810 04 04-00	Washer Lock Hvy. Helical 1/4			
141	819 09 12-10	Washer 9/32 x 3/4 x 10 Ga.			
155	812 00 00-28	Ring Retainer			
157	532 10 57-01	Washer Plate Shift			
158	532 19 43-52	Belt Keeper			
159	876 02 04-12	Pin Cotter 1/8 x 3/4			
160	532 16 94-84	Retainer Clip			
161	532 10 57-09	Spring, Return, Clutch			

NOTE: All component dimensions given in U.S. inches
1 inch = 25.4 mm

TRACTOR - - MODEL NUMBER LT151 (96041001706), PRODUCT NO. 960 41 00-17
ENGINE

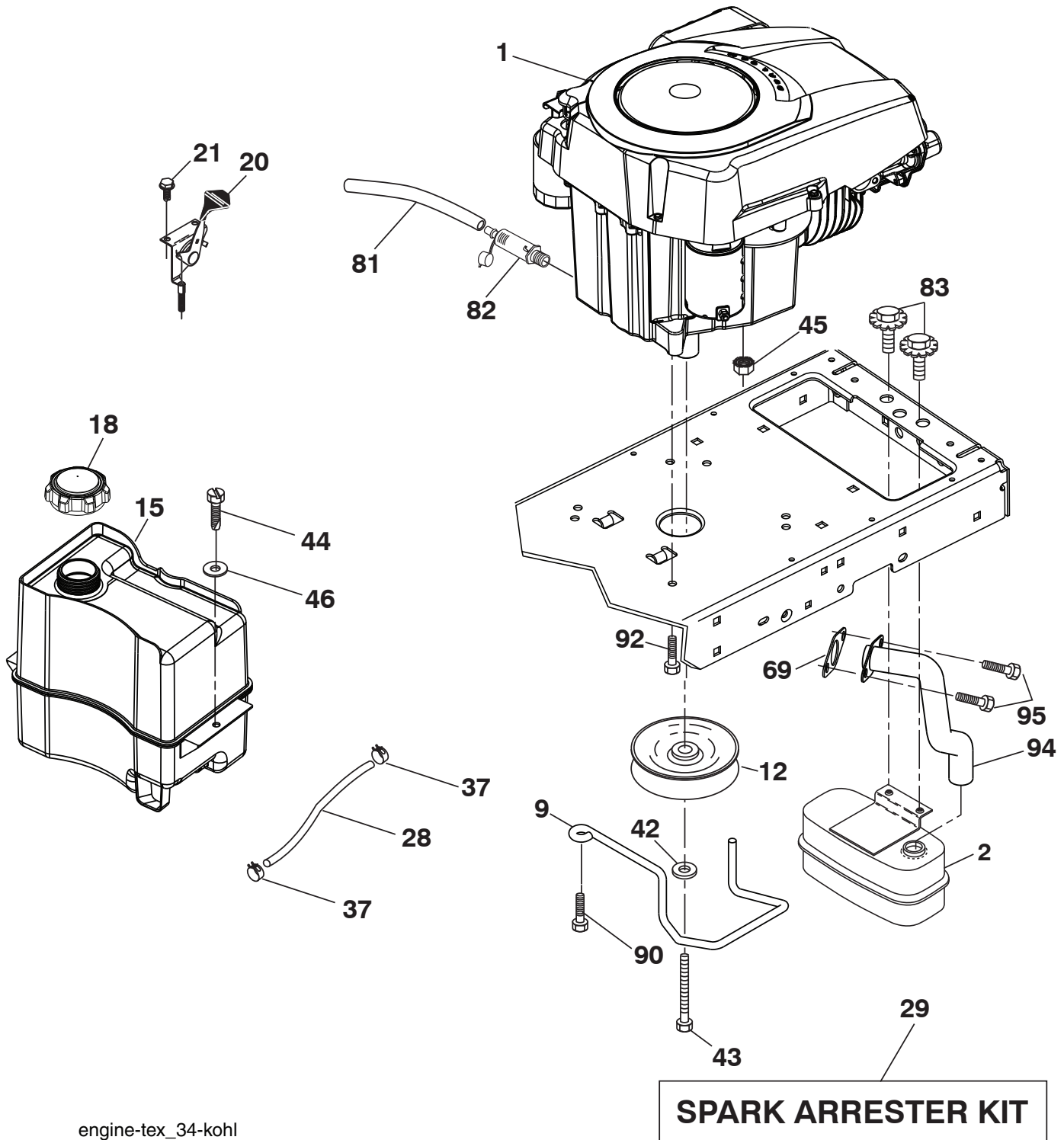

engine-tex_34-kohl

**TRACTOR - - MODEL NUMBER LT151 (96041001706), PRODUCT NO. 960 41 00-17
ENGINE**

KEY NO.	PART NO.	DESCRIPTION
1	-----	Engine Kohler Model No. SV470
2	532 18 86-55	Muffler
9	532 19 43-19	Keeper Belt Engine
12	532 40 19-85	Pulley Engine
15	532 40 75-45	Tank Fuel 1.5
18	532 19 77-25	Cap Asm.
20	532 18 38-97	Control Throttle
21	532 41 63-58	Screw #10 x 0.750 BOS Thread
28	532 13 70-40	Fuel Line
29	532 13 71-80	Spark Arrester Kit
37	532 12 34-87	Clamp Hose
41	810 04 07-00	Bolt 5/16-18 unc x 3/4 w/Sems.
43	532 17 39-37	Bolt Hex 7/16-20 x 4 Gr. 5
44	817 67 04-12	Screw 1/4-20 x 3/4
45	873 51 04-00	Nut Keps Hex 1/4-20 unc
46	819 09 14-16	Washer 9/32 x 7/8 x 16 Ga.
69	532 18 59-09	Gasket
81	532 14 84-56	Tube Drain Oil Easy
82	532 18 16-54	Plug Drain Oil
83	532 17 18-77	Bolt 5/16-18 unc x 3/4 w/Sems.
90	817 00 06-16	Screw 3/8-16 x 1
92	817 12 06-16	Screw 3/8-16 x 1
94	532 18 86-54	Tube Exhaust
95	532 19 23-34	Screw Socket HD 5/16-18 x .75

NOTE: All component dimensions given in U.S. inches
1 inch = 25.4 mm

**TRACTOR - - MODEL NUMBER LT151 (96041001706), PRODUCT NO. 960 41 00-17
STEERING ASSEMBLY**

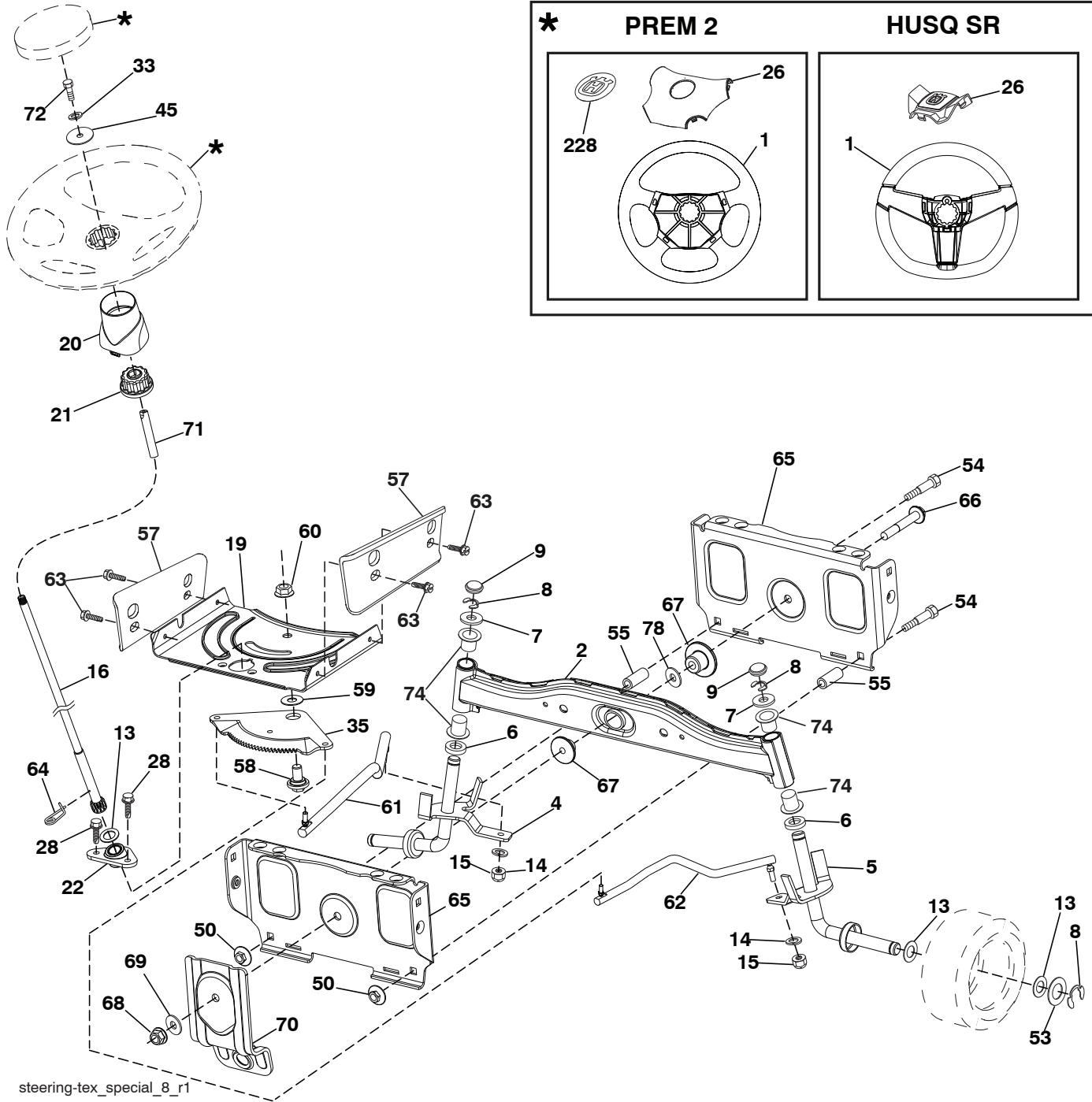

steering-tex_special_8_r1

**TRACTOR - - MODEL NUMBER LT151 (96041001706), PRODUCT NO. 960 41 00-17
STEERING ASSEMBLY**

KEY NO.	PART NO.	DESCRIPTION
1	532 41 64-80	Wheel, Steering Husq SR
--	532 19 36-51	Wheel, Steering Prem 2
2	532 41 81-68	Axle Asm., Front
4	532 40 30-87	Spindle Asm., LH
5	532 40 30-88	Spindle Asm., RH
6	532 12 49-31	Bearing, Race Thrust Hardened
7	532 12 17-48	Washer 25/32 x 1-5/8 x 16 Ga.
8	812 00 00-29	Ring, Clip #T5304-75
9	532 12 12-32	Cap, Spindle
13	532 12 17-49	Washer 25/32 x 1-1/4 x 16 Ga.
14	810 04 06-00	Washer, Lock Hvy. Hlcl. Spr. 3/8
15	873 54 06-00	Nut, Crown Lock 3/8-24 unf
16	532 19 60-74	Shaft Steering
19	532 19 47-29	Plate Steering
20	532 41 11-39	Boot, Steering
21	532 18 67-37	Adapter, Wheel Steering
22	532 19 48-45	Bushing, Strg. Blk.
26	532 41 59-87	Insert, Wheel Steering Husq SR
--	532 19 36-52	Insert, Wheel Steering Prem 2
28	817 00 06-12	Screw 3/8-16 x 3/4
33	810 04 05-00	Washer Lock 5/16
35	532 19 47-32	Gear, Sector Plate
45	819 11 38-12	Washer 11/32 x 3/8 x 12 Ga.
50	873 90 06-00	Nut Lock 3/8-16 unc
53	532 18 89-67	Washer Hardened .793 x 1.637 x .060
54	874 76 06-36	Bolt Hex 3/8-16 unc x 2-1/4
55	532 41 47-36	Spacer Brace Axle
57	532 40 74-65	Bracket Upstop
58	532 19 47-47	Bolt Shoulder Sector Pivot CFM
59	532 19 47-48	Washer Thrust Sector Steering
60	873 97 10-00	Nut Flange Lock 5/8-11
61	532 19 47-40	Draglink, LH
62	532 19 47-41	Draglink, RH
63	817 00 05-12	Screw 5/16-18 x 3/4
64	532 19 98-49	Retainer Clip Spring Steering
65	532 19 47-34	Brace Axle Front
66	871 02 07-48	Bolt Hex Fghd. 7/16-14 x 3 Serr.
67	532 19 47-37	Bushing PM Front Axle
68	873 90 07-00	Nut Lock Flange 7/16-14 Gr. 5
69	532 19 91-62	Washer 1.5 x .505 x .118
70	532 19 61-97	Bracket Deck Susp. Front
71	532 19 60-75	Shaft Extension Steering
72	874 78 05-72	Bolt 5/16-18 unc x 4.5. Gr. 5
74	532 12 49-37	Bearing Col. STRG
78	532 05 70-79	Washer Thrust 515.750 x .033
228	532 40 44-84	Decal Wheel Steering

NOTE: All component dimensions given in U.S. inches
1 inch = 25.4 mm

**TRACTOR - - MODEL NUMBER LT151 (96041001706), PRODUCT NO. 960 41 00-17
MOWER DECK**

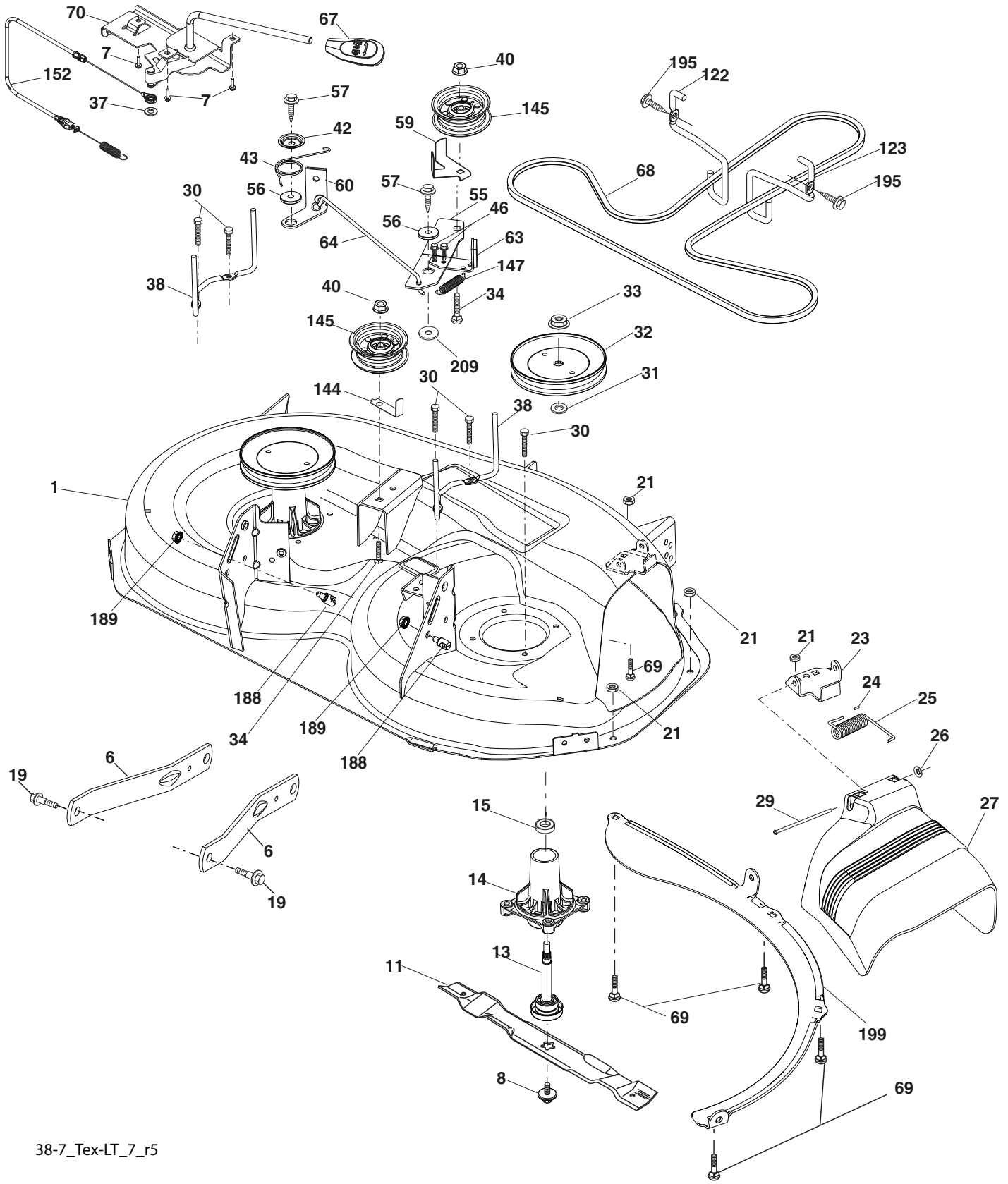

38-7_Tex-LT_7_r5

**TRACTOR - - MODEL NUMBER LT151 (96041001706), PRODUCT NO. 960 41 00-17
MOWER DECK**

KEY NO.	PART NO.	DESCRIPTION	KEY NO.	PART NO.	DESCRIPTION
1	532 19 42-51	Mower Housing	59	532 14 10-43	Guard, Tuv. Idler
6	532 19 51-86	Arm Suspension	60	532 19 94-71	Arm Brake Mower
7	532 41 63-58	Screw #10 x BOS Thread	63	532 19 94-70	Arm Brake Mower
8	532 19 30-03	Bolt/Washer Asm. 7/16-20 unf	64	532 19 97-90	Link Brake
11	532 19 39-57	Blade 38" 3NI Premium	67	532 40 30-12	Handle Clutch Cable
13	532 19 28-72	Shaft Assembly, Mandrel	68	532 40 83-81	V-Belt
14	532 18 72-81	Housing, Mandrel	69	872 14 05-05	Bolt
15	532 11 04-85	Bearing, Ball, Mandrel	70	532 40 12-46	Clutch Asm. Manual
19	532 19 65-39	Bolt, Shoulder	122	532 19 72-58	Keeper Belt Engine LH
21	873 68 05-00	Nut, Crownlock 5/16-18 unc	123	532 19 72-59	Keeper Belt Engine RH
23	532 19 25-57	Bracket, Deflector	144	532 19 34-14	Keeper Belt
24	532 10 53-04	Cap, Sleeve	145	532 19 31-97	Pulley, Idler, Flat
25	532 19 70-26	Spring, Torsion, Deflector	147	532 40 18-72	Spring Return
26	532 11 04-52	Nut, Push	152	532 40 87-14	Manual Clutch Cable
27	532 40 14-72	Shield, Deflector	188	532 19 51-61	Stud Fastener
29	532 13 14-91	Rod, Hinge	189	873 90 05-00	Nut Lock Hex Flange
30	532 17 39-84	Screw Thdrol. Rolling Wsh. Hd.	195	817 00 06-12	Screw 3/8-16 x 3/4
31	532 18 76-90	Washer, Spacer	199	532 40 00-95	Baffle Vortex
32	532 19 97-89	Pulley, Mandrel	209	819 13 32-10	Washer 13/32 x 2 x 10
33	532 40 02-34	Nut, Toplock, Flanged	--	532 19 28-70	Mandrel Assembly (Includes hous- ing, shaft and shaft hardware only- pulley not included)
34	872 11 06-12	Bolt Carr. Sh. 3/8-16 x 1-1/2 Gr. 5	--	532 40 04-22	Replacement Mower, Complete
37	819 13 13-16	Washer			
38	532 19 95-41	Keeper Belt LH Mandrel			
40	873 90 06-00	Nut, Lock Flg. 3/8-16 unc			
42	532 19 84-10	Spring Torsion Brake			
43	532 19 72-56	Spring Torsion Retainer			
46	532 13 77-29	Screw 1/4-20 x 5/8			
55	532 19 72-49	Arm, Idler			
56	532 19 90-92	Spacer, Retainer			
57	817 00 06-16	Screw 3/8-16 x 1			

NOTE: All component dimensions given in U.S. inches
1 inch = 25.4 mm

**TRACTOR - - MODEL NUMBER LT151 (96041001706), PRODUCT NO. 960 41 00-17
SEAT ASSEMBLY**

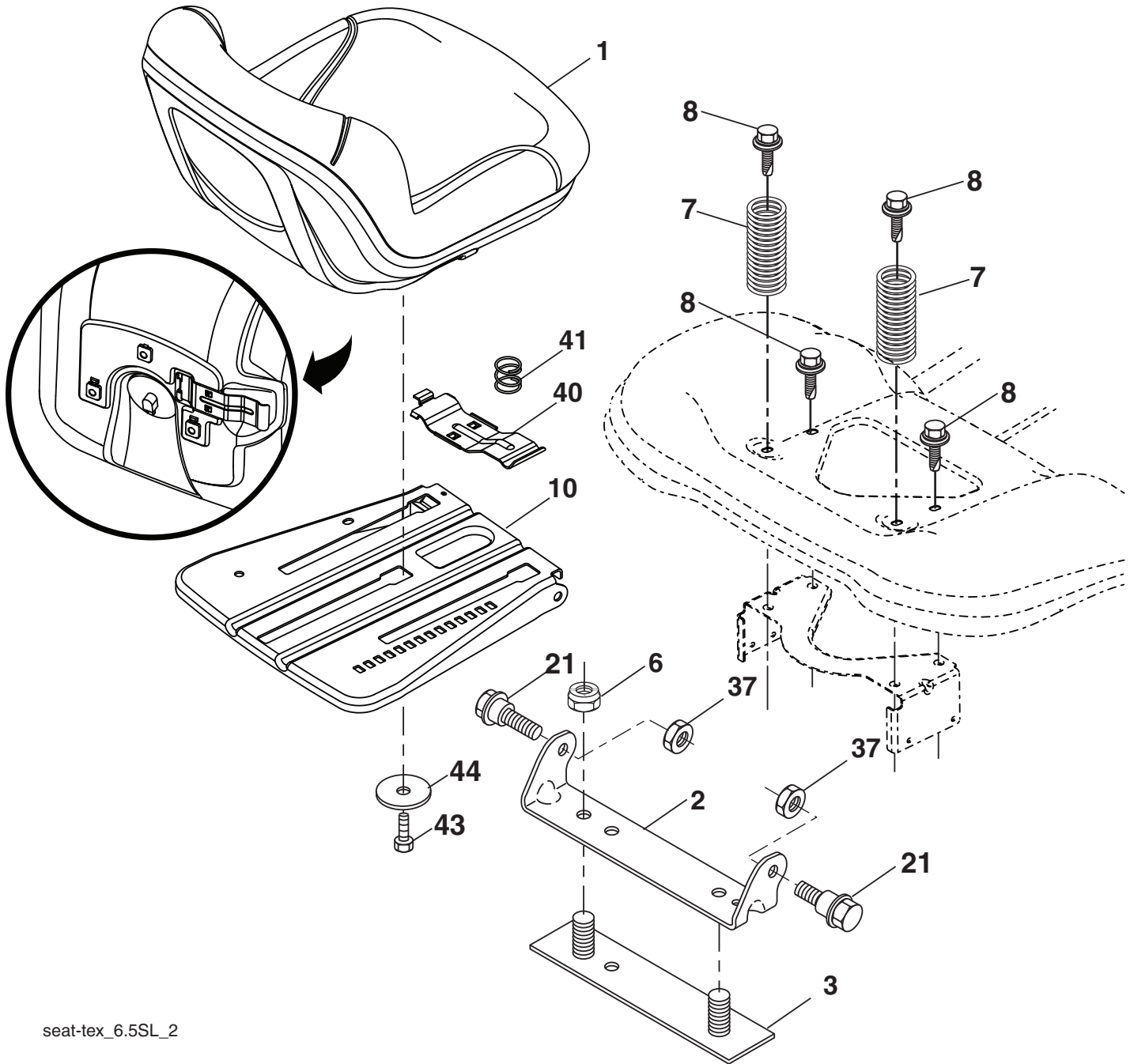

seat-tex_6.5SL_2

KEY NO.	PART NO.	DESCRIPTION
1	532 19 75-18	Seat
2	532 18 01-66	Bracket Pivot Fender
3	532 14 06-75	Strap, Asm. Fender
6	873 80 06-00	Nut, Lock w/Ins. 3/8-16 unc
7	532 12 41-81	Spring, Seat Cprsn.
8	532 17 18-77	Bolt 5/16-18 unc x 3/4 w/Sems.
10	532 19 69-77	Pan, Seat
21	532 17 18-52	Bolt, Shoulder 5/16-18
37	873 80 05-00	Nut, Lock 5/16-18 unc

KEY NO.	PART NO.	DESCRIPTION
40	532 19 76-61	Handle
41	532 19 82-00	Spring
43	874 76 06-12	Bolt 3/8-16 unc x 3/4
44	819 13 38-12	Washer 13/32 x 2-3/8 x 12 Ga.

NOTE: All component dimensions given in U.S. inches
1 inch = 25.4 mm

**TRACTOR - - MODEL NUMBER LT151 (96041001706), PRODUCT NO. 960 41 00-17
MOWER LIFT**

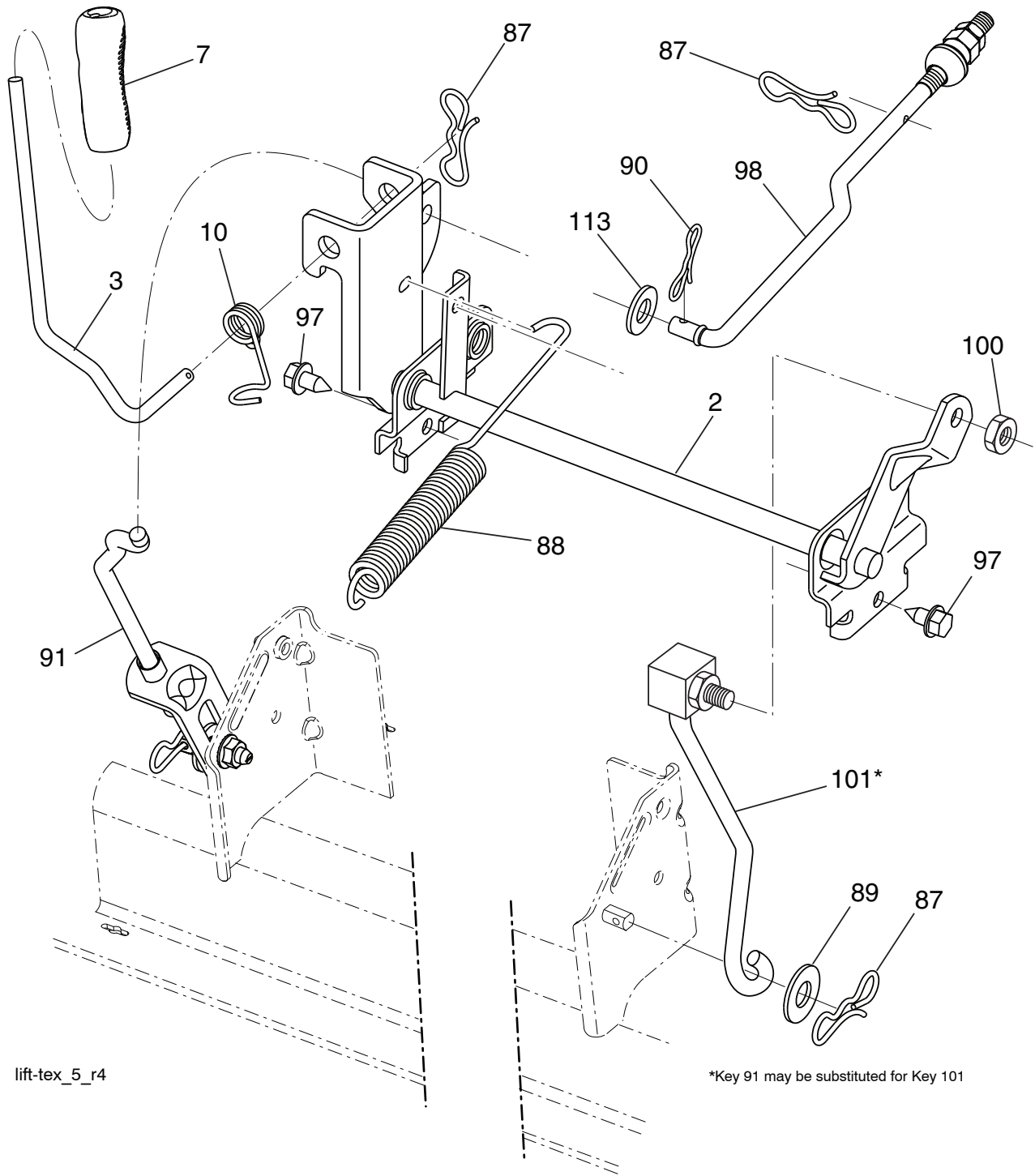

lift-tex_5_r4

*Key 91 may be substituted for Key 101

KEY NO.	PART NO.	DESCRIPTION
2	532 19 52-23	Shaft Asm., Lift
3	532 19 52-31	Lever Asm., Lift RH
7	532 41 15-55	Grip, Lever
10	532 19 63-14	Spring Torsion
87	532 19 42-09	Pin Cotter 7/16 Bow Tie Lock
88	532 41-07-10	Spring Lift Assist
89	819 19 19-12	Washer Clear Zinc
90	532 19 42-08	Pin Cotter 5/16 Bow Tie Lock

KEY NO.	PART NO.	DESCRIPTION
91	532 19 51-81	Link Lift Susp. Mower Rear
97	817 00 06-12	Screw 3/8-16 x .75 Smgml. Tap/R.Z
98	532 19 52-70	Link Lift Susp. Front Mower
100	873 93 06-00	Nut Centerlock 3/8-16
101	532 40-70-03	Link Asm. Lift FXD

NOTE: All component dimensions given in U.S. inches
1 inch = 25.4 mm