

1130 STE

Spare parts

Ersatzteile

Pièces détachées

Reserve onderdelen

Repuestos

Reservdelar

REPAIR PARTS

AUGER HOUSING / IMPELLER ASSEMBLY

SNOW THROWER - MODEL NO. 1130STE (96191001906), PRODUCT NO. 961 91 00-19

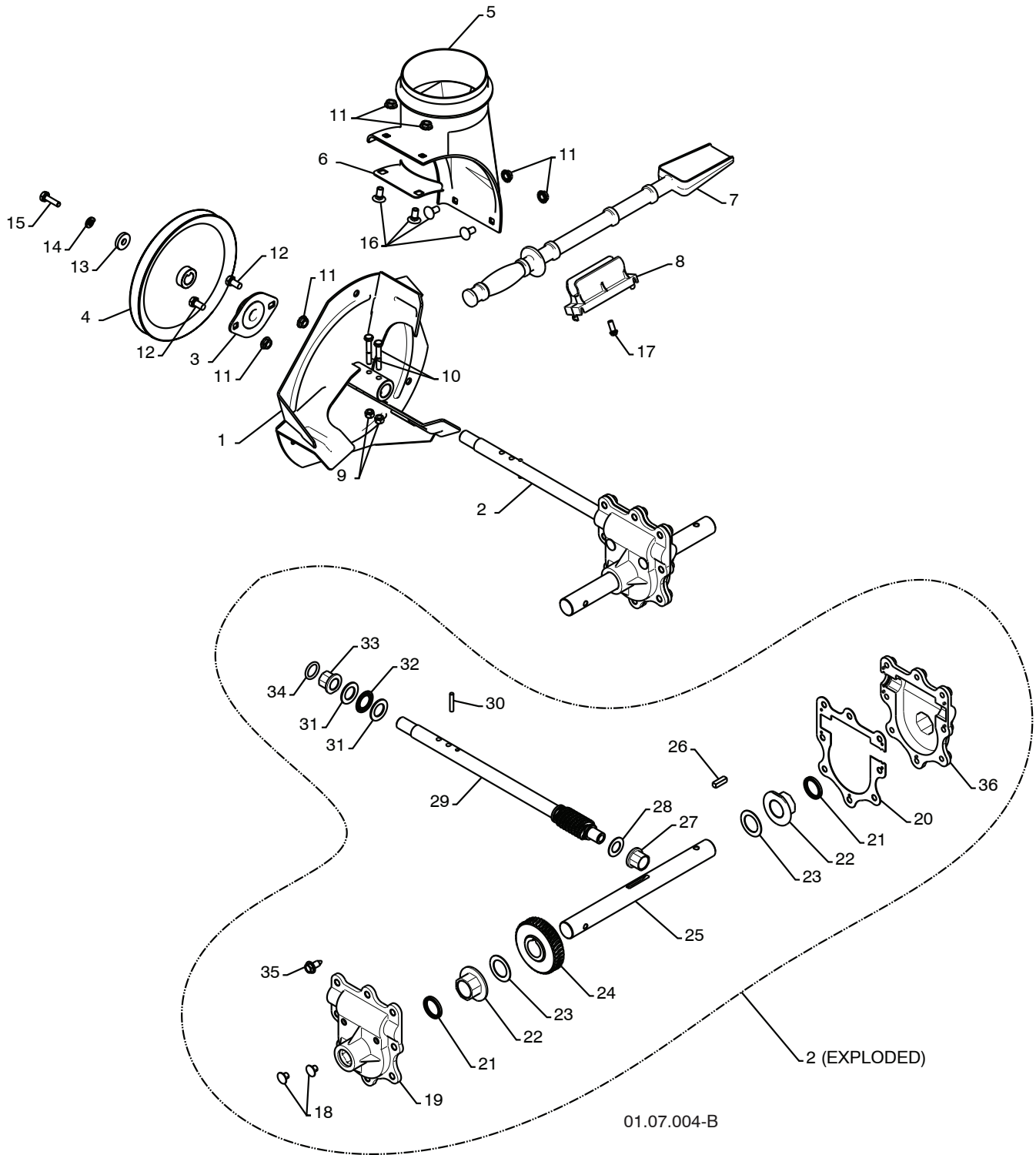

NOTE: All component dimensions given in U.S. inches. 1 inch = 25.4 mm
IMPORTANT: Use only Original Equipment Manufacturer (O.E.M.) replacement parts.
Failure to do so could be hazardous, damage your snow thrower and void your warranty.

REPAIR PARTS

AUGER HOUSING / IMPELLER ASSEMBLY

SNOW THROWER - MODEL NO. **1130STE** (96191001906), PRODUCT NO. 961 91 00-19

KEY NO.	PART NO.	DESCRIPTION
1	532 18 41-05	IMPELLER
2	532 19 67-10	GEARBOX ASSEMBLY
3	532 18 89-09	BEARING
4	532 19 10-79	IMPELLER PULLEY
5	532 17 53-22	DISCHARGE BASE
6	532 18 40-95	CORNER BRACKET
7	532 19 21-99	CLEAN OUT TOOL
8	532 40 54-00	TOOL CLIP
9	873 80 04-00	NUT 1/4-20
10	874 78 04-26	SCREW 1/4-20 X .625
11	532 15 53-77	NUT 5/16-18
12	532 16 31-83	SCREW 5/16-18 X .625
13	819 11 15-07	WASHER
14	810 04 05-00	LOCKWASHER 5/16
15	874 94 05-16	SCREW 5/16-18 X 1.00
16	532 18 03-55	CARRIAGE BOLT
17	532 19 41-89	SCREW 13-16 X .625
18	532 40 77-60	PLUG
19	532 40 77-61	GEARBOX COVER RH
20	532 40 77-66	GASKET
21	532 40 77-70	SEAL
22	532 40 77-62	BEARING
23	532 17 46-97	THRUST WASHER 1.00
24	532 40 77-63	WORM GEAR
25	532 40 77-64	AUGER SHAFT
26	532 18 92-82	SQUARE KEY
27	532 40 77-58	BEARING
28	532 17 46-83	THRUST WASHER
29	532 40 77-57	IMPELLER SHAFT
30	532 18 42-05	ROLL PIN
31	532 17 46-81	THRUST WASHER
32	532 17 46-84	THRUST BEARING
33	532 40 77-69	BEARING
34	532 40 77-68	O-RING
35	532 40 77-67	SCREW 5/16-18 X .750
36	532 40 77-65	GEARBOX COVER LH

NOTE: All component dimensions given in U.S. inches. 1 inch = 25.4 mm

IMPORTANT: Use only Original Equipment Manufacturer (O.E.M.) replacement parts. Failure to do so could be hazardous, damage your snow thrower and void your warranty.

REPAIR PARTS

AUGER HOUSING / IMPELLER ASSEMBLY

SNOW THROWER - MODEL NO. 1130STE (96191001906), PRODUCT NO. 961 91 00-19

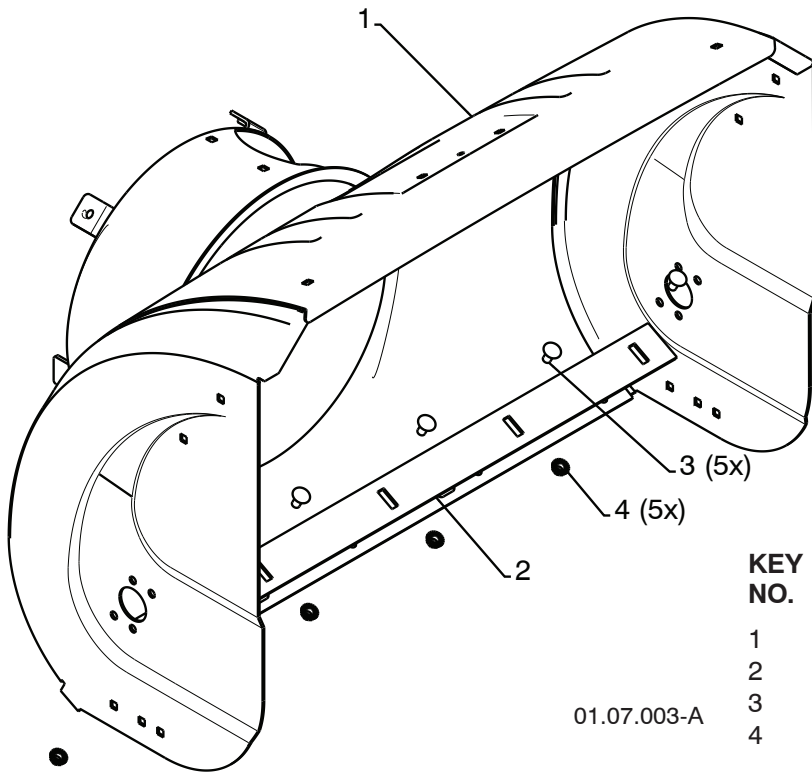

01.07.003-A

KEY NO.	PART NO.	DESCRIPTION
1	532 40 77-21	AUGER HOUSING
2	532 40 76-45	SCRAPER BAR
3	872 27 05-05	CARRIAGEBOLT 5/16-18X.625
4	532 15 53-77	NUT 5/16-18

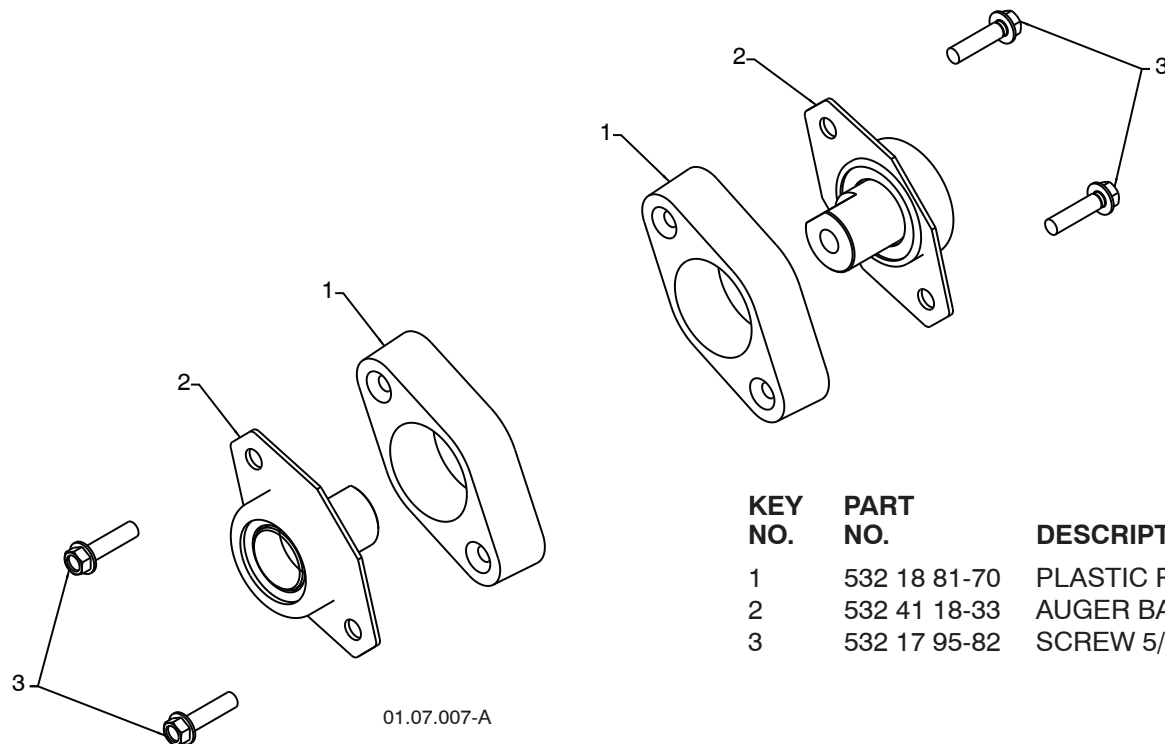

01.07.007-A

KEY NO.	PART NO.	DESCRIPTION
1	532 18 81-70	PLASTIC RETAINER
2	532 41 18-33	AUGER BALL BEARING
3	532 17 95-82	SCREW 5/16-18 X 1.00

NOTE: All component dimensions given in U.S. inches. 1 inch = 25.4 mm
IMPORTANT: Use only Original Equipment Manufacturer (O.E.M.) replacement parts.
 Failure to do so could be hazardous, damage your snow thrower and void your warranty.

REPAIR PARTS

AUGER HOUSING / IMPELLER ASSEMBLY

SNOW THROWER - MODEL NO. 1130STE (96191001906), PRODUCT NO. 961 91 00-19

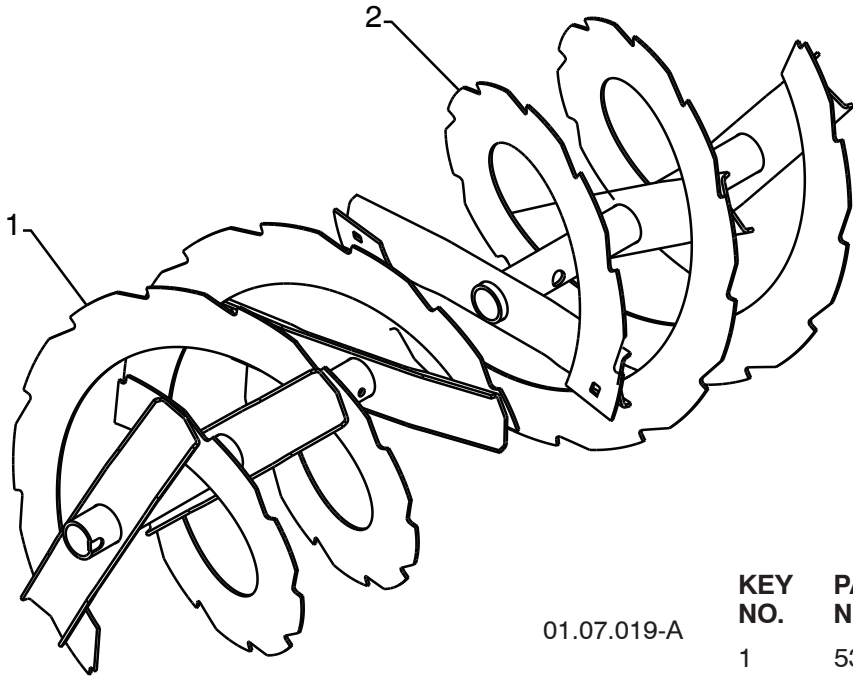

01.07.019-A

KEY NO.	PART NO.	DESCRIPTION
1	532 42 11-24	AUGER ASSEMBLY 30 LH
2	532 42 11-25	AUGER ASSEMBLY 30 RH

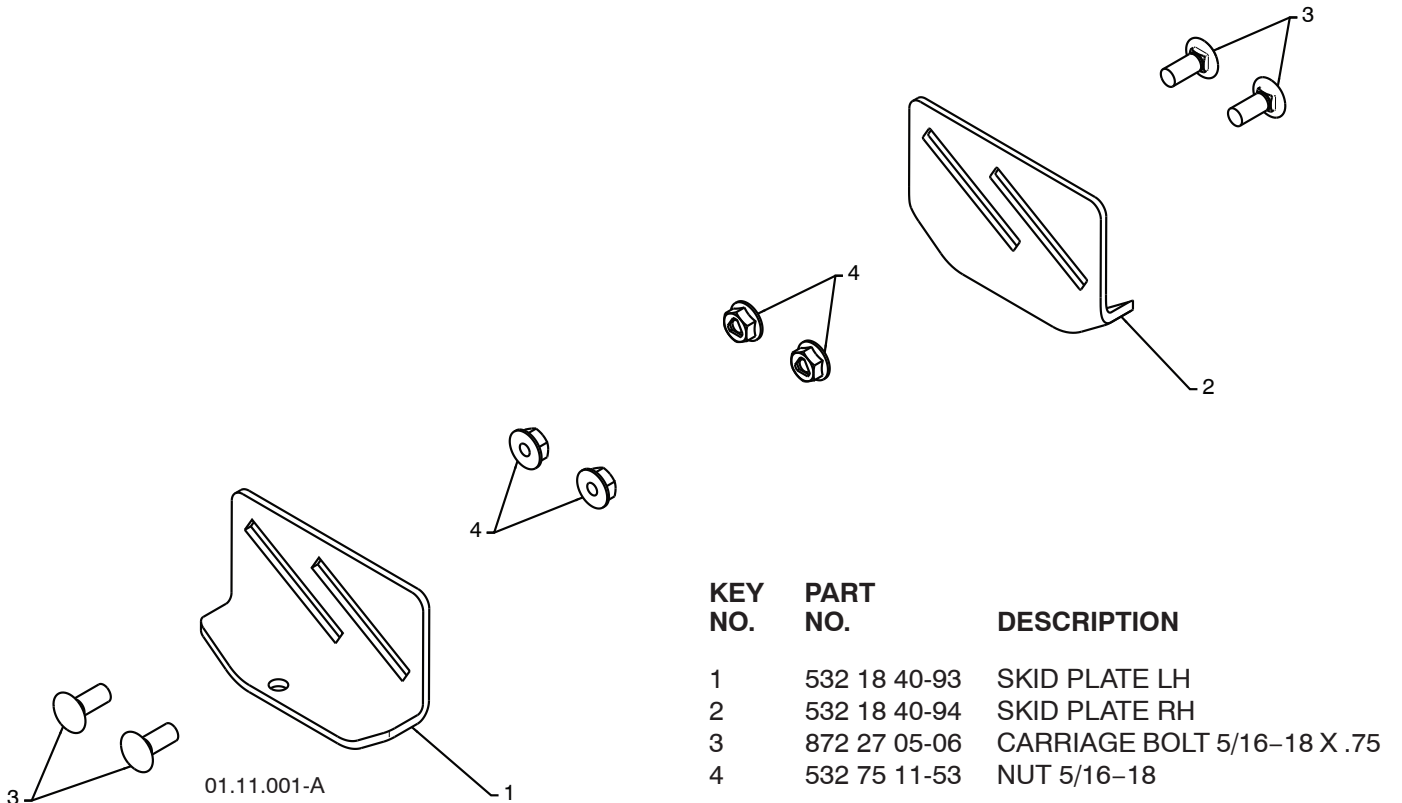

01.11.001-A

KEY NO.	PART NO.	DESCRIPTION
1	532 18 40-93	SKID PLATE LH
2	532 18 40-94	SKID PLATE RH
3	872 27 05-06	CARRIAGE BOLT 5/16-18 X .75
4	532 75 11-53	NUT 5/16-18

NOTE: All component dimensions given in U.S. inches. 1 inch = 25.4 mm
IMPORTANT: Use only Original Equipment Manufacturer (O.E.M.) replacement parts. Failure to do so could be hazardous, damage your snow thrower and void your warranty.

REPAIR PARTS

AUGER HOUSING / IMPELLER ASSEMBLY

SNOW THROWER - MODEL NO. 1130STE (96191001906), PRODUCT NO. 961 91 00-19

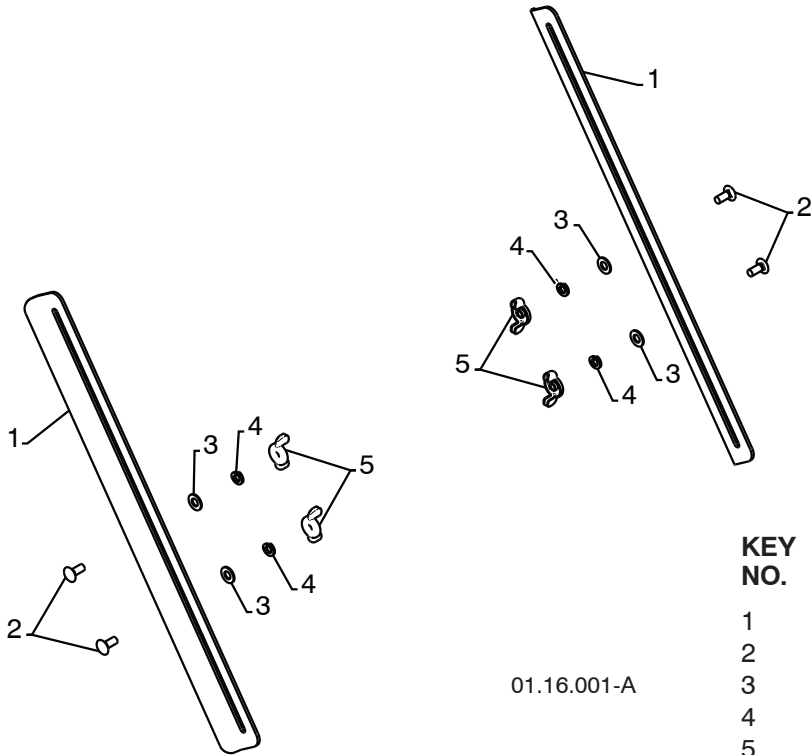

01.16.001-A

KEY NO.	PART NO.	DESCRIPTION
1	532 18 47-47	DRIFT CUTTER BAR
2	872 27 05-06	CARRIAGE BOLT 5/16-18X.750
3	532 17 92-46	PLASTIC WASHER
4	810 04 05-00	LOCKWASHER 5/16
5	532 12 86-38	NUT 5/16-18

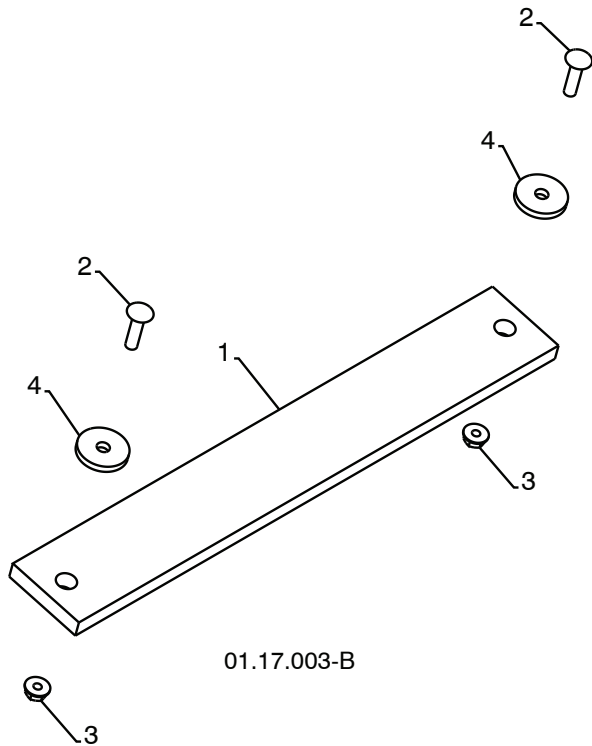

01.17.003-B

KEY NO.	PART NO.	DESCRIPTION
1	532 18 25-16	WEIGHT BAR
2	872 11 05-10	CARRIAGE BOLT 5/16-18 X 1.25
3	532 75 11-53	NUT 5/16-18
4	819 11 22-06	WASHER

NOTE: All component dimensions given in U.S. inches. 1 inch = 25.4 mm
IMPORTANT: Use only Original Equipment Manufacturer (O.E.M.) replacement parts.
 Failure to do so could be hazardous, damage your snow thrower and void your warranty.

REPAIR PARTS

CONTROL PANEL / DISCHARGE CHUTE

SNOW THROWER - MODEL NO. 1130STE (96191001906), PRODUCT NO. 961 91 00-19

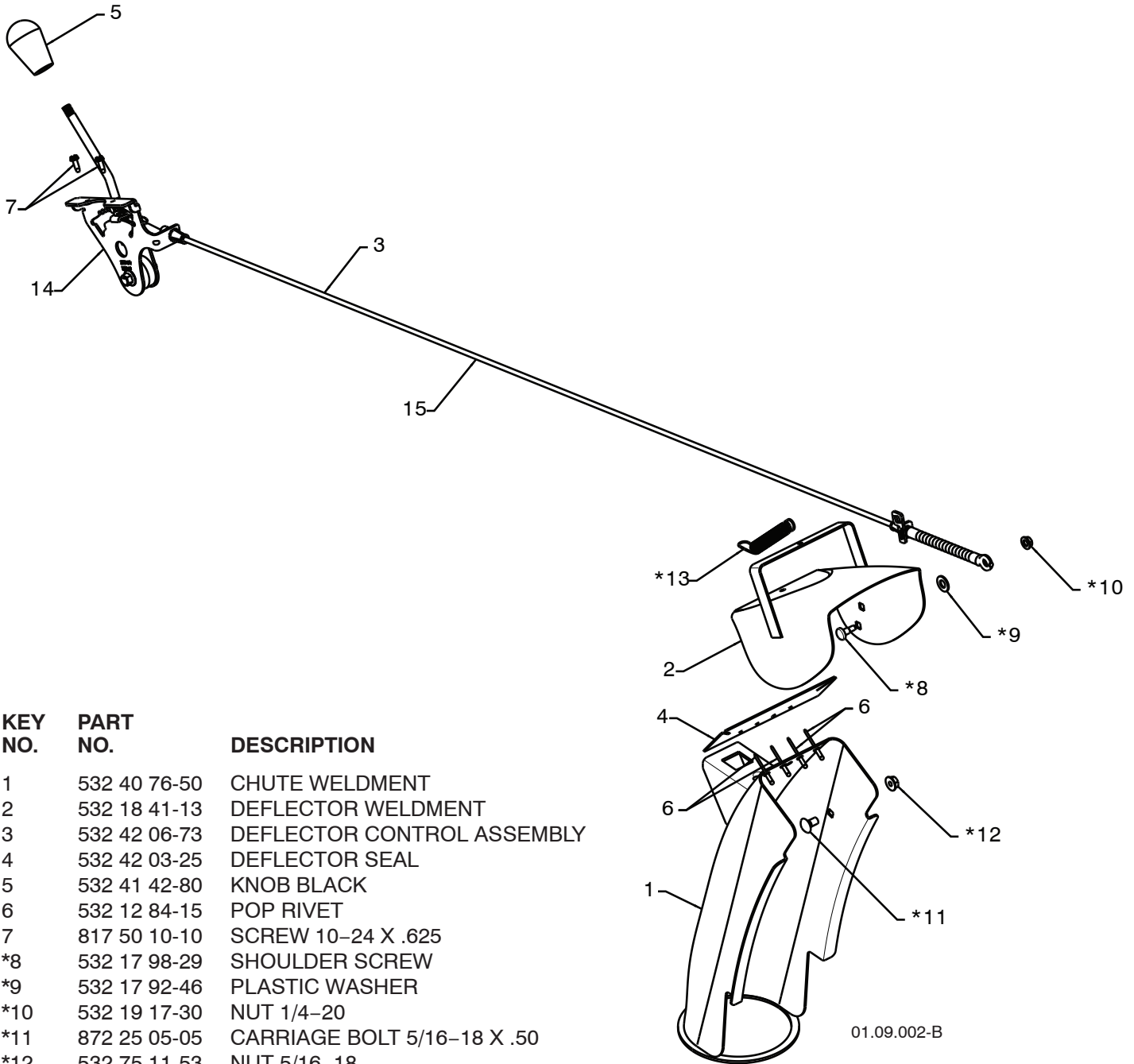

KEY NO.	PART NO.	DESCRIPTION
1	532 40 76-50	CHUTE WELDMENT
2	532 18 41-13	DEFLECTOR WELDMENT
3	532 42 06-73	DEFLECTOR CONTROL ASSEMBLY
4	532 42 03-25	DEFLECTOR SEAL
5	532 41 42-80	KNOB BLACK
6	532 12 84-15	POP RIVET
7	817 50 10-10	SCREW 10-24 X .625
*8	532 17 98-29	SHOULDER SCREW
*9	532 17 92-46	PLASTIC WASHER
*10	532 19 17-30	NUT 1/4-20
*11	872 25 05-05	CARRIAGE BOLT 5/16-18 X .50
*12	532 75 11-53	NUT 5/16-18
*13	532 18 45-05	DEFLECTOR SPRING
14	532 42 06-79	(SERVICE PART) DEFLECTOR CONTROL HEAD
15	532 42 06-72	(SERVICE PART) DEFLECTOR CONTROL CABLE

01.09.002-B

NOTE:

- ALL ITEMS INDICATED WITH AN * ARE PROVIDED IN THE BAG OF ITEMS SHIPPED LOOSE WITH PRODUCT.
- ITEMS 14 AND 15 ARE SERVICE PART NUMBERS TO ALLOW PURCHASE OF INDIVIDUAL ITEMS IF NECESSARY.

NOTE: All component dimensions given in U.S. inches. 1 inch = 25.4 mm
IMPORTANT: Use only Original Equipment Manufacturer (O.E.M.) replacement parts. Failure to do so could be hazardous, damage your snow thrower and void your warranty.

REPAIR PARTS

CONTROL PANEL / DISCHARGE CHUTE

SNOW THROWER - MODEL NO. 1130STE (96191001906), PRODUCT NO. 961 91 00-19

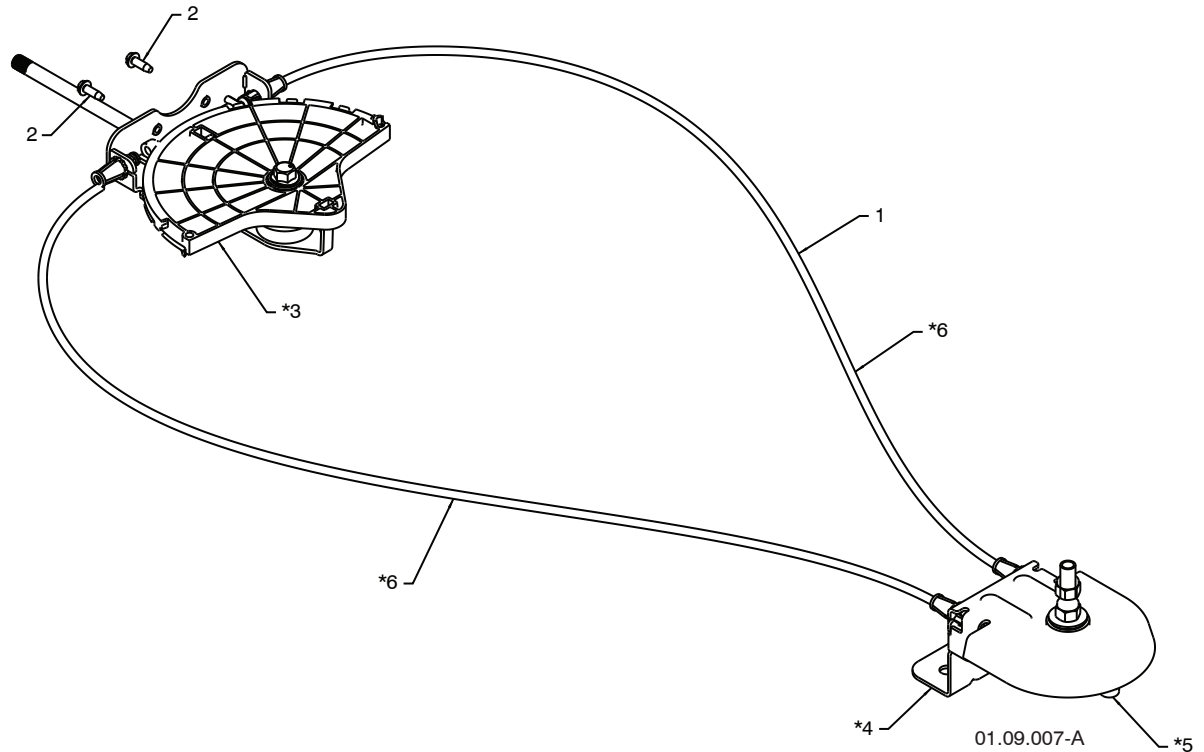

KEY NO.	PART NO.	DESCRIPTION
1	532 42 03-37	LEVER/CABLE ROTATOR ASSEMBLY
2	817 50 10-10	SCREW 10-24 X .625
*3	532 42 06-78	ROTATOR HEAD
*4	532 42 06-77	ROTATOR PIVOT BRACKET
*5	532 42 06-75	PULLEY PIVOT
*6	532 42 06-74	CABLE ASSEMBLY

NOTES:

1. ITEMS INDICATED WITH AN * ARE LISTED AS REFERENCE FOR SERVICE PARTS ONLY.

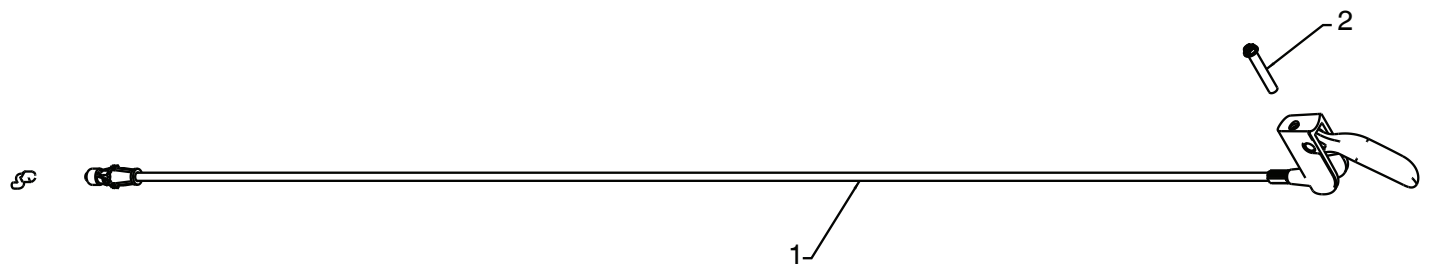

KEY NO.	PART NO.	DESCRIPTION
1	532 19 24-49	STEER CABLE BLUE
2	874 04 10-24	SCREW 10-24 X 1.50

NOTE: All component dimensions given in U.S. inches. 1 inch = 25.4 mm
IMPORTANT: Use only Original Equipment Manufacturer (O.E.M.) replacement parts. Failure to do so could be hazardous, damage your snow thrower and void your warranty.

REPAIR PARTS

HANDLES

SNOW THROWER - MODEL NO. 1130STE (96191001906), PRODUCT NO. 961 91 00-19

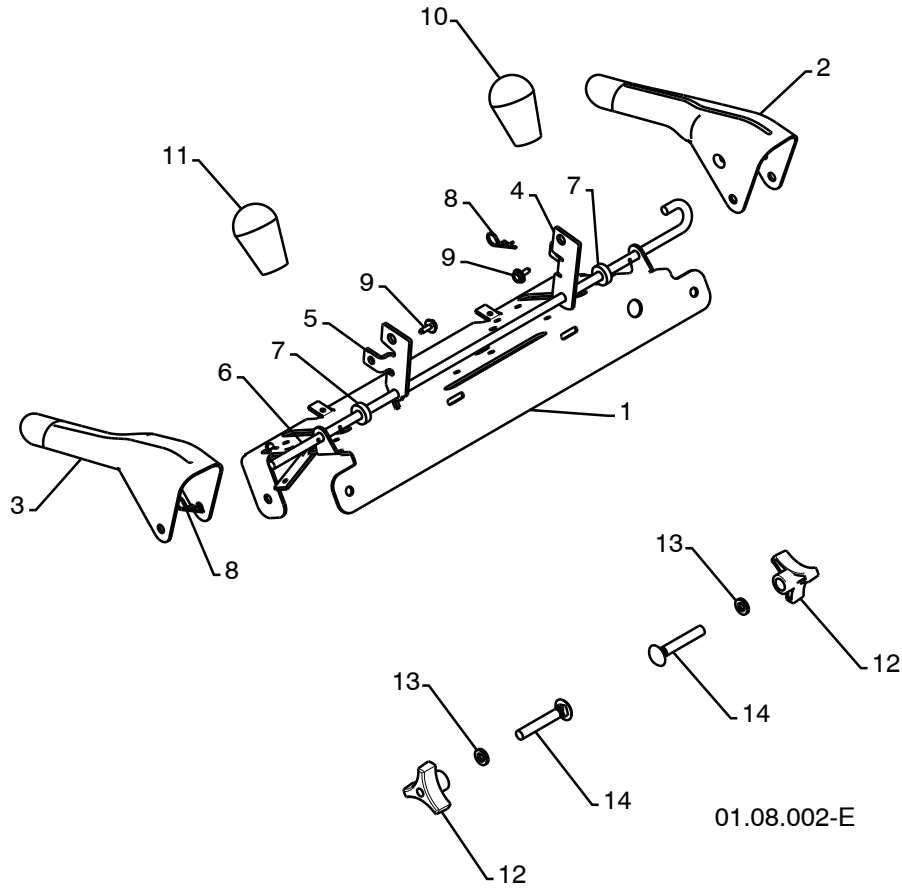

KEY NO.	PART NO.	DESCRIPTION
1	532 41 55-39	CONTROL PANEL
2	532 41 55-41	CONTROL LEVER LH
3	532 41 55-42	CONTROL LEVER RH
4	532 41 55-46	TRACTION ROD ARM
5	532 42 14-92	IMPELLER ROD ARM
6	532 41 26-77	INTERLOCK ROD
7	532 42 16-13	SPACER
8	532 16 96-75	RETAINER
9	817 06 04-08	SCREW 1/4-20 X .50
10	532 41 42-80	KNOB BLACK
11	532 41 42-81	KNOB RED
12	532 17 88-99	HANDLE KNOB
13	819 13 13-16	WASHER 3/8
14	872 12 06-18	CARRIAGE BOLT 3/8-16 X 2.25

NOTE: All component dimensions given in U.S. inches. 1 inch = 25.4 mm
IMPORTANT: Use only Original Equipment Manufacturer (O.E.M.) replacement parts. Failure to do so could be hazardous, damage your snow thrower and void your warranty.

REPAIR PARTS

HANDLES

SNOW THROWER - MODEL NO. **1130STE** (96191001906), PRODUCT NO. 961 91 00-19

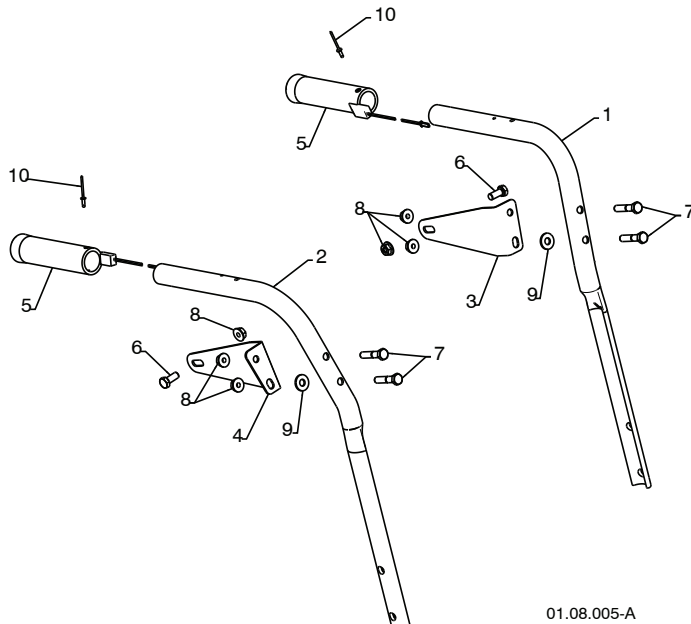

KEY NO.	PART NO.	DESCRIPTION
1	532 42 10-69	PLOW HANDLE LH
2	532 42 10-70	PLOW HANDLE RH
3	532 19 69-44	PANEL BRACKET LH
4	532 19 69-43	PANEL BRACKET RH
5	532 41 45-15	HEATED HANDLE GRIP
6	874 78 05-12	CREW 5/16-18 X .750
7	874 78 05-24	SCREW 5/16-18 X 1.50
8	532 75 11-53	NUT 5/16-18
9	532 15 54-15	WASHER
10	532 17 87-75	POP RIVET 1/8

01.08.005-A

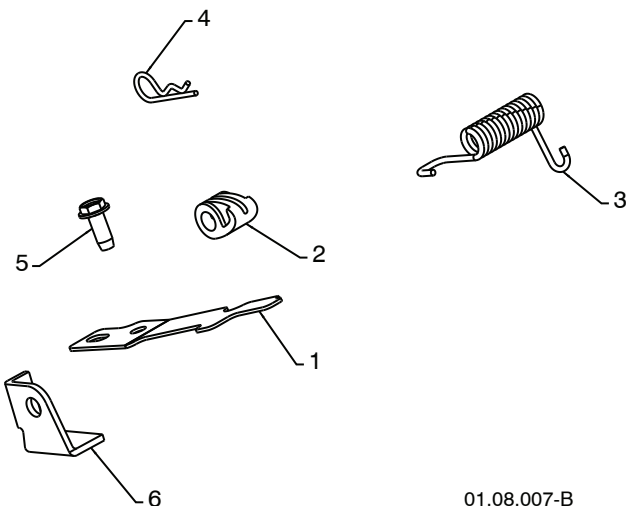

KEY NO.	PART NO.	DESCRIPTION
1	532 41 62-88	INTERLOCK SPRING
2	532 41 45-72	INTERLOCK CAM
3	532 17 88-31	TORSION SPRING
4	532 16 96-75	RETAINER
5	817 06 04-10	SCREW 1/4-20 X .625
6	532 42 18-14	INTERLOCK STOP

01.08.007-B

NOTE: All component dimensions given in U.S. inches. 1 inch = 25.4 mm
IMPORTANT: Use only Original Equipment Manufacturer (O.E.M.) replacement parts. Failure to do so could be hazardous, damage your snow thrower and void your warranty.

REPAIR PARTS

HANDLES

SNOW THROWER - MODEL NO. 1130STE (96191001906), PRODUCT NO. 961 91 00-19

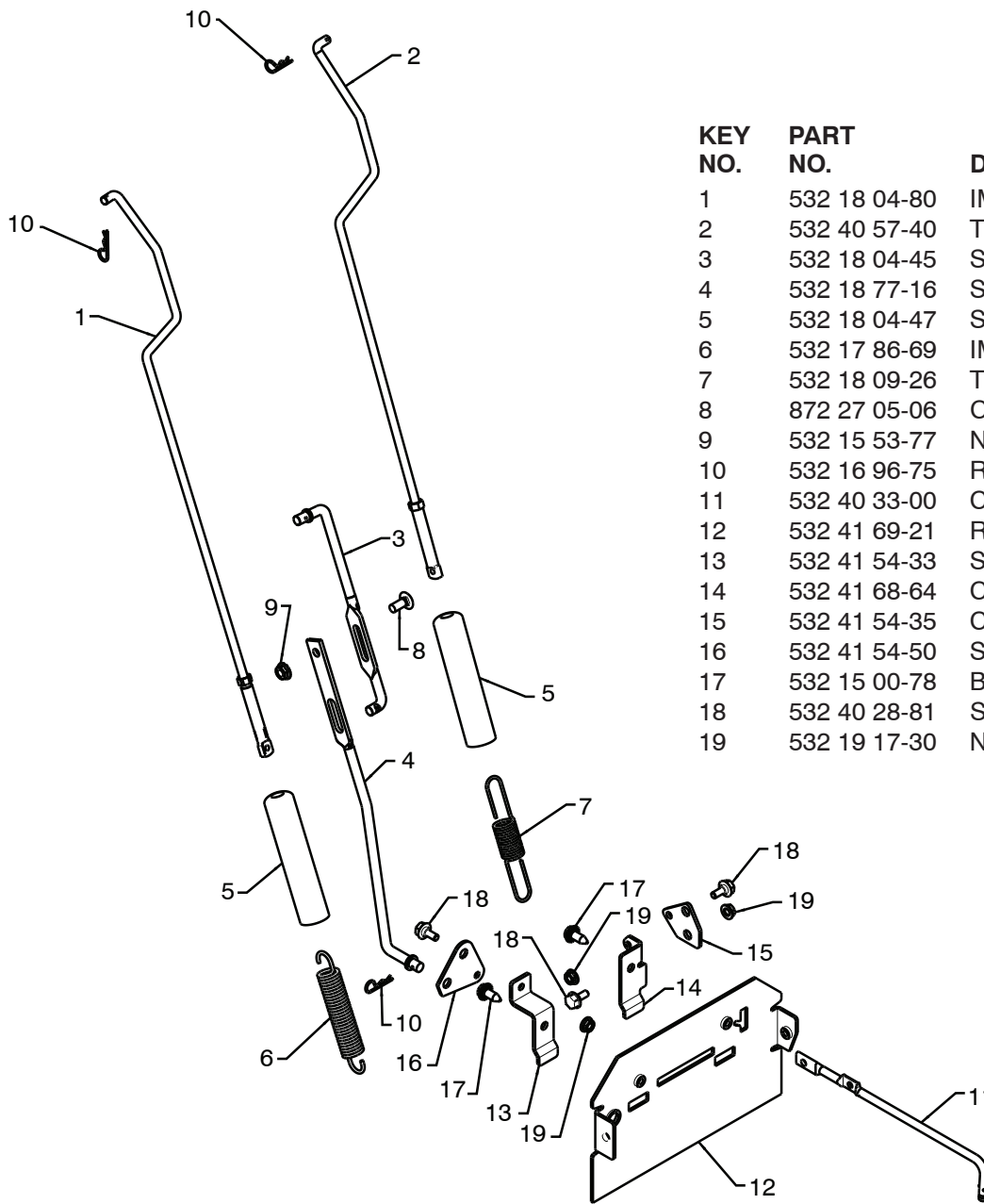

KEY NO.	PART NO.	DESCRIPTION
1	532 18 04-80	IMPELLER ROD ASSEMBLY
2	532 40 57-40	TRACTION ROD ASSEMBLY
3	532 18 04-45	SHIFTER ROD TOP
4	532 18 77-16	SHIFTER ROD BOTTOM
5	532 18 04-47	SPRING SLEEVE
6	532 17 86-69	IMPELLER SPRING
7	532 18 09-26	TRACTION SPRING
8	872 27 05-06	CARRIAGE BOLT 5/16-18 X .750
9	532 15 53-77	NUT 5/16-18
10	532 16 96-75	RETAINER
11	532 40 33-00	CLUTCH ROD
12	532 41 69-21	REAR PLATE
13	532 41 54-33	SHIFTER PLATE BRACKET
14	532 41 68-64	CLUTCH PLATE BRACKET
15	532 41 54-35	CLUTCH PLATE
16	532 41 54-50	SHIFTER PLATE
17	532 15 00-78	BOLT 5/16-18 X .750
18	532 40 28-81	SHOULDER BOLT 1/4-20 X .500
19	532 19 17-30	NUT 1/4-20

NOTE: All component dimensions given in U.S. inches. 1 inch = 25.4 mm
IMPORTANT: Use only Original Equipment Manufacturer (O.E.M.) replacement parts.
 Failure to do so could be hazardous, damage your snow thrower and void your warranty.

REPAIR PARTS

HANDLES

SNOW THROWER - MODEL NO. 1130STE (96191001906), PRODUCT NO. 961 91 00-19

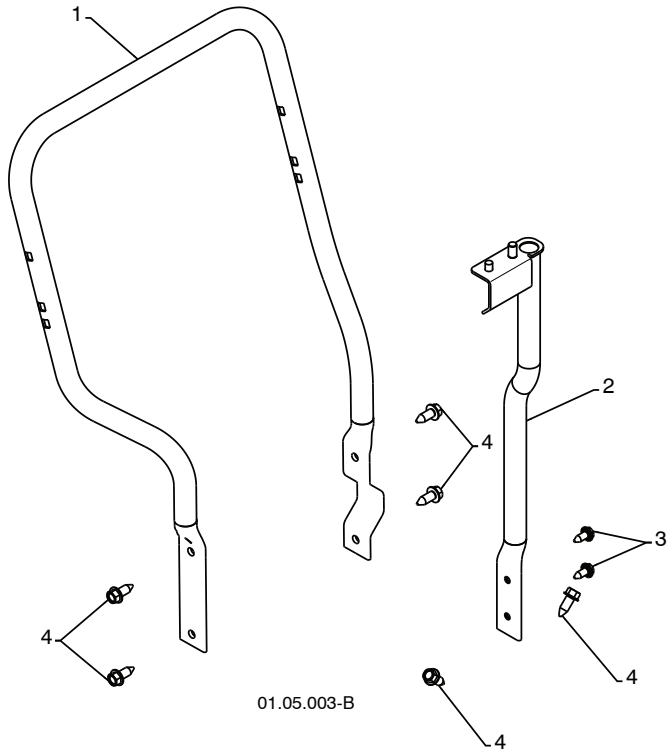

KEY NO.	PART NO.	DESCRIPTION
1	532 42 10-59	LOWER TUBE
2	532 42 21-17	PIVOT SUPPORT
3	532 15 00-78	BOLT 5/16-18 X .750
4	817 00 06-16	SCREW 3/8-16 X 1.00

KEY NO.	PART NO.	DESCRIPTION
1	532 41 39-27	CONSOLE PANEL BLACK
2	532 17 86-68	HEADLIGHT BEZEL
3	532 17 86-66	HALOGEN HEADLIGHT
4	532 18 44-71	SHOULDERSCREW 10-24X.625
5	532 17 52-62	SCREW 10-24 X 1.25
6	532 41 77-60	GRIP SWITCH
7	532 40 56-99	WIRE HARNESS
8	532 40 16-20	BULB

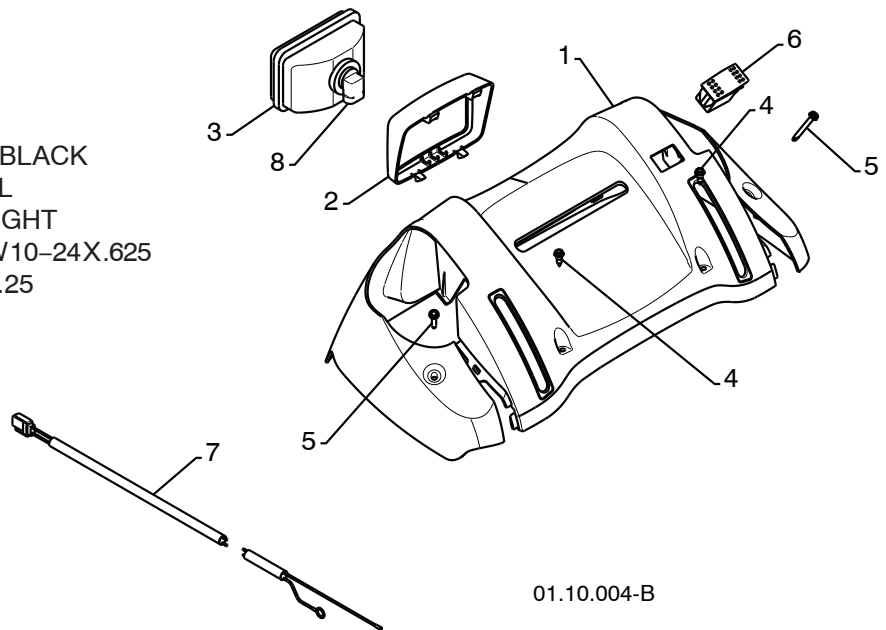

NOTE: All component dimensions given in U.S. inches. 1 inch = 25.4 mm
IMPORTANT: Use only Original Equipment Manufacturer (O.E.M.) replacement parts. Failure to do so could be hazardous, damage your snow thrower and void your warranty.

REPAIR PARTS

DRIVE

SNOW THROWER - MODEL NO. 1130STE (96191001906), PRODUCT NO. 961 91 00-19

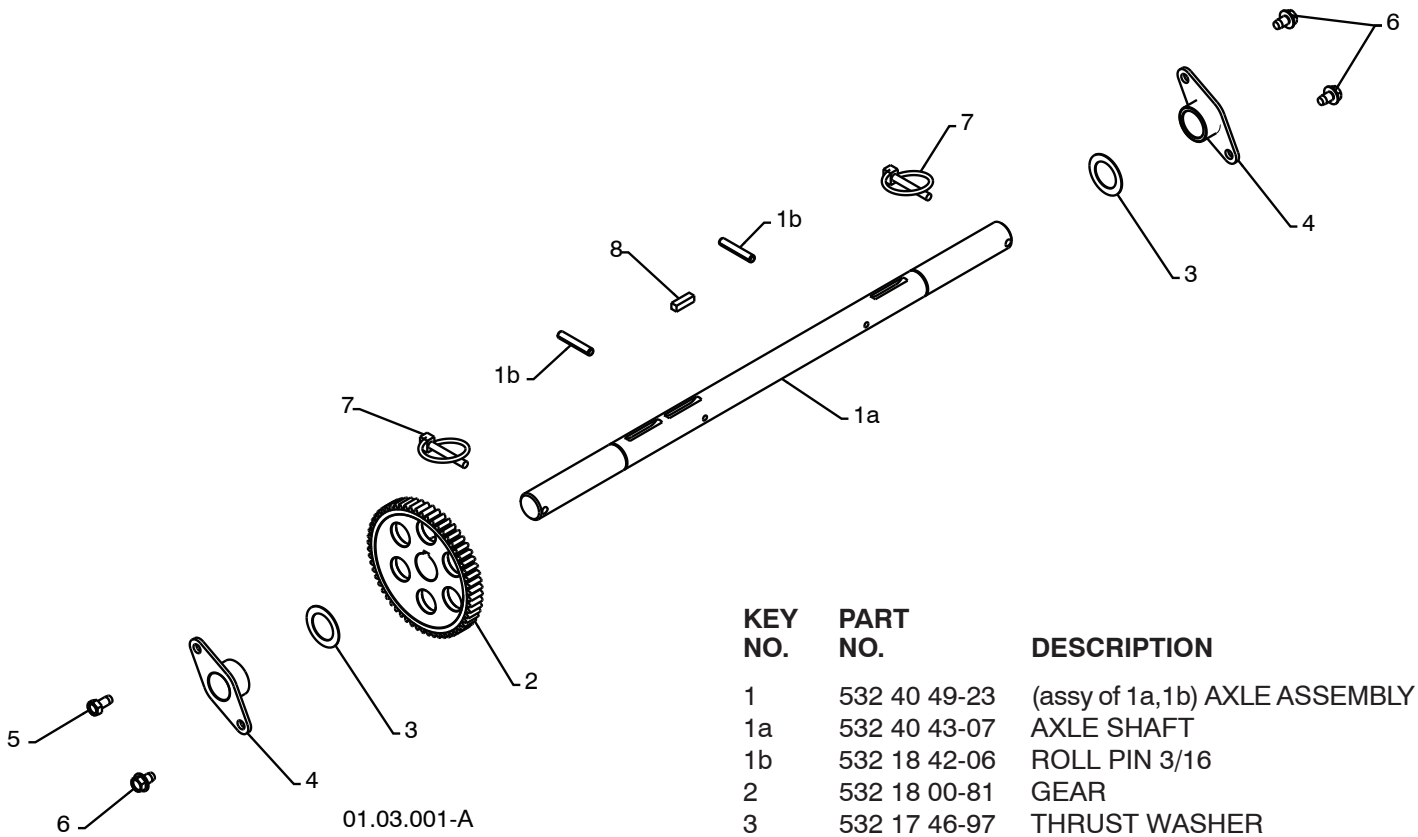

KEY NO.	PART NO.	DESCRIPTION
1	532 40 49-23	(assy of 1a,1b) AXLE ASSEMBLY
1a	532 40 43-07	AXLE SHAFT
1b	532 18 42-06	ROLL PIN 3/16
2	532 18 00-81	GEAR
3	532 17 46-97	THRUST WASHER
4	532 17 98-30	AXLE BEARING
5	532 14 63-15	SCREW 5/16-18 X .625
6	817 49 05-08	BOLT 5/16-18 X .500
7	532 15 54-43	CLIK PIN
8	532 18 92-82	SQUARE KEY

NOTE: All component dimensions given in U.S. inches. 1 inch = 25.4 mm

IMPORTANT: Use only Original Equipment Manufacturer (O.E.M.) replacement parts. Failure to do so could be hazardous, damage your snow thrower and void your warranty.

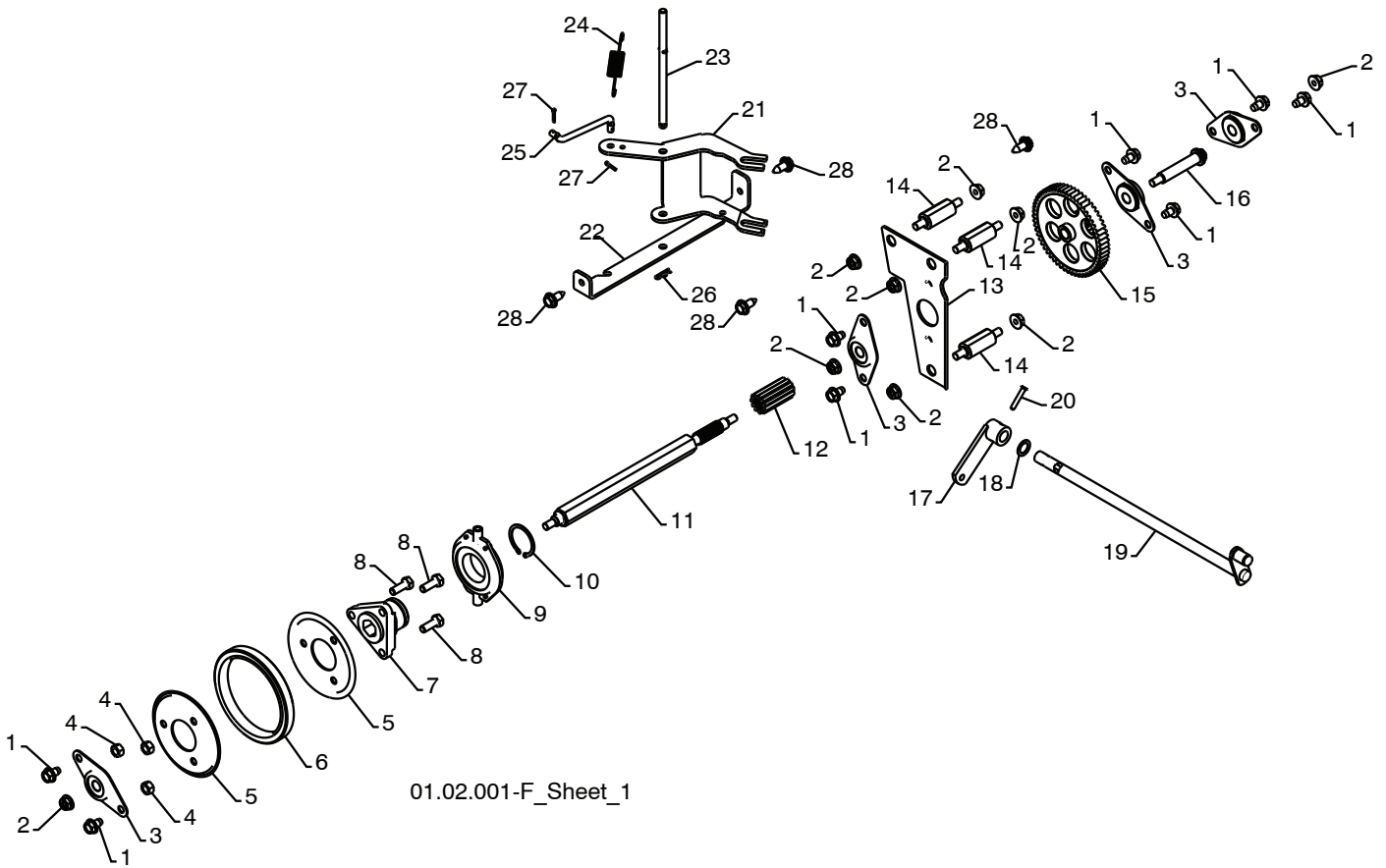

01.02.001-F_Sheet_1

REPAIR PARTS

DRIVE

SNOW THROWER - MODEL NO. **1130STE** (96191001906), PRODUCT NO. 961 91 00-19

KEY NO.	PART NO.	DESCRIPTION
1	817 49 05-08	BOLT 5/16-18 X .500
2	532 75 11-53	NUT 5/16-18
3	532 18 00-17	FLANGE BEARING
4	873 93 05-00	NUT 5/16-18
5	532 19 95-09	RUBBER WHEEL PLATE
6	532 17 98-31	RUBBER WHEEL RING
7	532 17 86-13	RUBBER WHEEL HUB
8	874 76 05-14	BOLT 5/16-18 X .875
9	532 17 53-44	TRUNNION BEARING ASSEMBLY
10	812 00 00-12	RETAINER
11	532 18 00-66	HEX SHAFT
12	532 18 00-65	PINION GEAR
13	532 19 29-07	AUXILIARY PLATE
14	532 17 92-70	SPACER PLATE
15	532 18 00-82	INTERMEDIATE GEAR
16	532 18 01-34	AUXILIARY SHAFT
17	532 40 54-85	CONTROL ARM
18	532 05 70-79	WASHER
19	532 40 61-09	CONTROL SHAFT ASSEMBLY
20	532 19 85-80	CLEVIS PIN
21	532 18 40-80	SHIFTER LEVER
22	532 18 78-57	PIVOT BRACKET
23	532 17 88-07	PIVOT PIN
24	532 18 01-35	SPRING
25	532 18 71-01	SHIFTER LINK
26	532 08 51-79	RETAINER
27	532 70 02-79	CLIP
28	532 15 00-78	BOLT 5/16-18 x .750

NOTE: All component dimensions given in U.S. inches. 1 inch = 25.4 mm

IMPORTANT: Use only Original Equipment Manufacturer (O.E.M.) replacement parts. Failure to do so could be hazardous, damage your snow thrower and void your warranty.

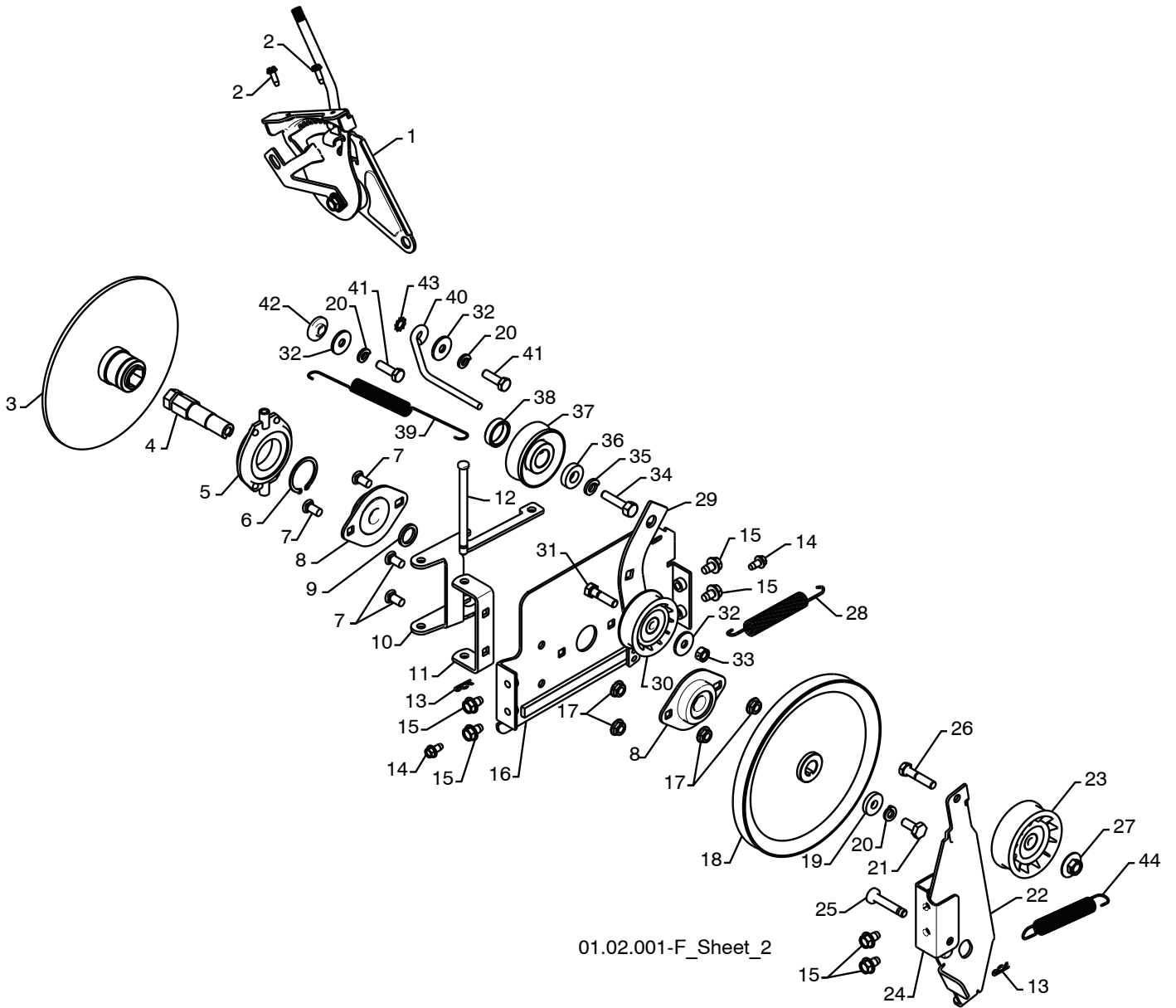

REPAIR PARTS**DRIVE****SNOW THROWER - MODEL NO. 1130STE (96191001906), PRODUCT NO. 961 91 00-19**

KEY NO.	PART NO.	DESCRIPTION
1	532 19 84-74	SPEED SELECTOR HEAD ASSEMBLY
2	817 50 10-10	SCREW 10-24 X .625
3	532 19 77-63	DRIVE PLATE WELDMENT
4	532 19 77-64	HEX SHAFT
5	532 17 53-44	TRUNNION BEARING ASSEMBLY
6	812 00 00-12	RETAINER
7	872 27 05-05	CARRIAGE BOLT 5/16-18 X .625
8	532 18 89-09	FLANGE BEARING
9	532 18 25-04	SPACER
10	532 18 40-77	LEVER SHIFTER PLATE
11	532 18 40-76	SHIFTER SUPPORT BRACKET
12	532 17 86-95	PIN
13	532 08 51-79	RETAINER
14	817 49 04-08	SCREW 1/4-20 X .500
15	817 49 05-08	BOLT 5/16-18 X .500
16	532 18 40-75	DRIVE MOUNT PLATE
17	532 15 53-77	NUT 5/16-18
18	532 19 10-80	TRACTION PULLEY
19	819 11 15-07	WASHER
20	810 04 05-00	LOCKWASHER 5/16
21	874 95 05-12	SCREW 5/16-18 X .750
22	532 42 21-11	IDLER BRAKE ARM
23	532 18 05-23	IDLER PULLEY
24	532 18 40-74	IDLER PIVOT BRACKET
25	532 17 53-30	PIN
26	874 78 05-24	SCREW 5/16-18 X 1.50
27	532 16 67-85	NUT 5/16-18
28	532 18 10-44	TRACTION SPRING
29	532 17 93-54	IDLER TRACTION ARM
30	532 18 05-22	IDLER PULLEY
31	874 78 05-20	SCREW 5/16-18 X 1.25
32	532 05 92-89	WASHER
33	873 93 05-00	NUT 5/16-18
34	532 85 10-84	SCREW 3/8-24 X 1.38
35	532 85 02-63	LOCKWASHER 3/8
36	532 40 00-26	WASHER
37	532 18 04-78	ENGINE TRACTION PULLEY
38	532 40 94-75	SPACER
39	532 17 90-95	RETURN SPRING
40	532 15 54-52	BELT GUIDE
41	874 61 05-16	SCREW 5/16-18 X 1.00
42	532 17 53-31	BUSHING
43	811 05 05-00	LOCKWASHER 5/16
44	532 17 88-28	BRAKE SPRING

NOTE: All component dimensions given in U.S. inches. 1 inch = 25.4 mm**IMPORTANT:** Use only Original Equipment Manufacturer (O.E.M.) replacement parts. Failure to do so could be hazardous, damage your snow thrower and void your warranty.

REPAIR PARTS

CHASSIS / PULLEYS

SNOW THROWER - MODEL NO. **1130STE** (96191001906), PRODUCT NO. 961 91 00-19

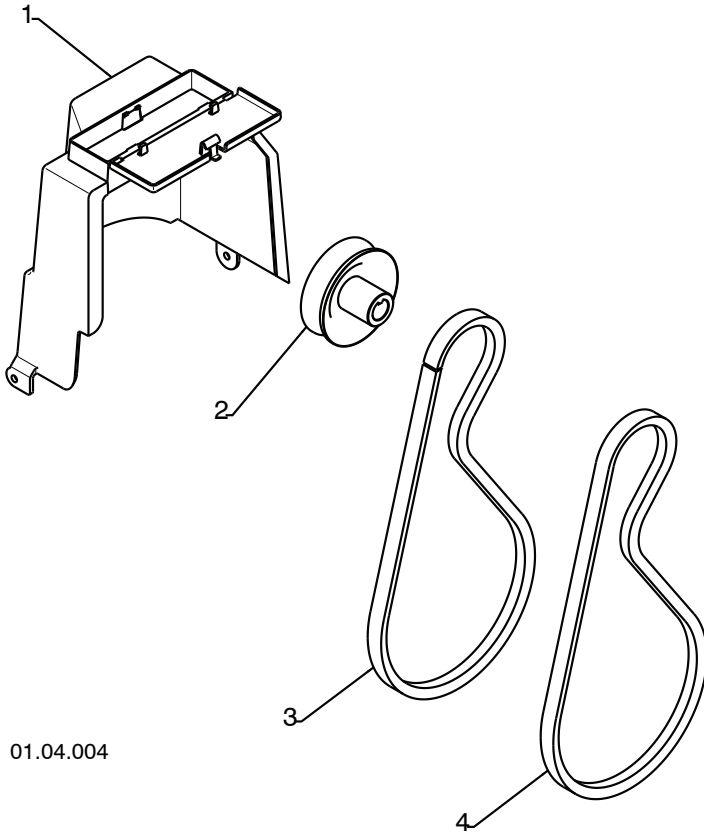

KEY NO.	PART NO.	DESCRIPTION
1	532 40 91-61	COVER ASSEMBLY
2	532 17 88-13	PULLEY
3	532 41 97-44	TRACTION BELT
4	532 40 80-19	IMPELLER BELT

01.04.004

NOTE: All component dimensions given in U.S. inches. 1 inch = 25.4 mm
IMPORTANT: Use only Original Equipment Manufacturer (O.E.M.) replacement parts.
Failure to do so could be hazardous, damage your snow thrower and void your warranty.

REPAIR PARTS

CHASSIS / PULLEYS

SNOW THROWER - MODEL NO. 1130STE (96191001906), PRODUCT NO. 961 91 00-19

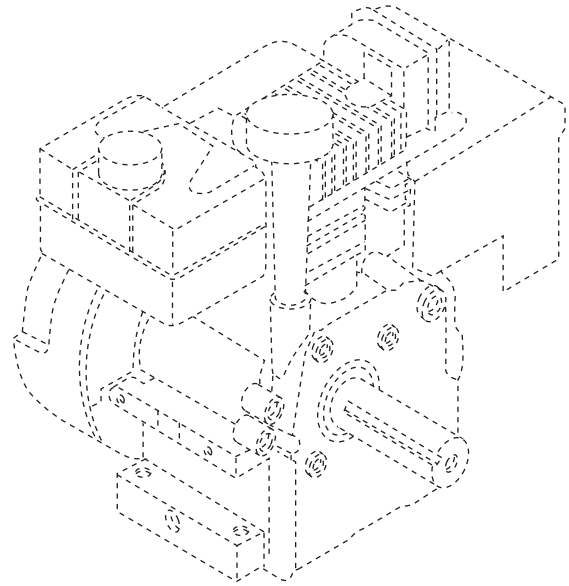
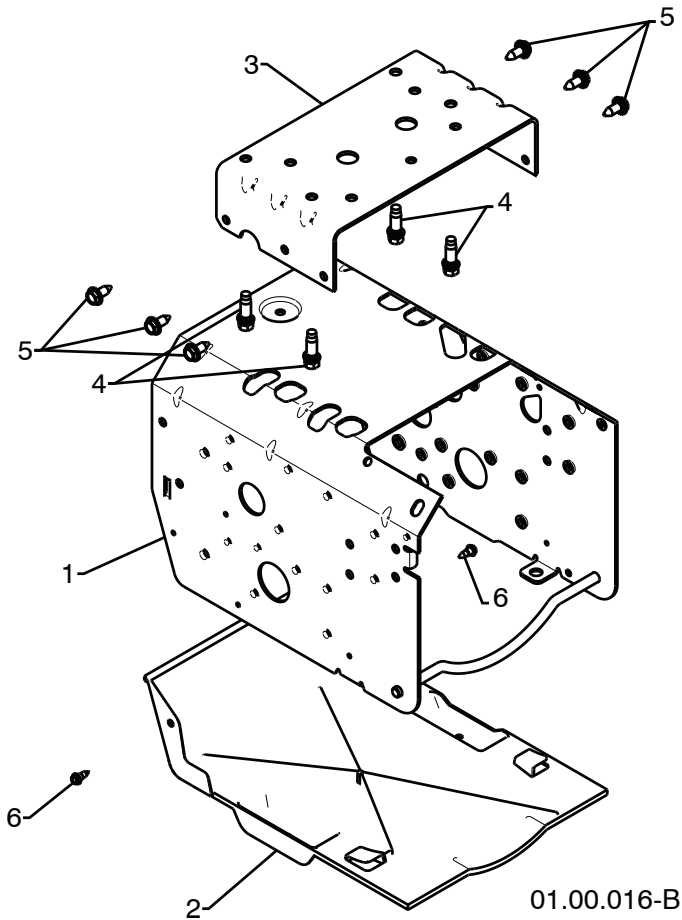

KEY NO.	PART NO.	DESCRIPTION
--	-----	B & S ENGINE, MODEL NUMBER 21M214-0920-E1
1	532 41 53-40	FRAME
2	532 41 08-77	BOTTOM PAN
3	532 42 38-70	ENGINE MOUNT PLATE
4	532 15 04-06	BOLT 3/8-16
5	532 15 00-78	SCREW 5/16-18 X .750
6	532 18 44-71	SCREW 10-24 X .625

NOTE: All component dimensions given in U.S. inches. 1 inch = 25.4 mm
IMPORTANT: Use only Original Equipment Manufacturer (O.E.M.) replacement parts. Failure to do so could be hazardous, damage your snow thrower and void your warranty.

REPAIR PARTS

WHEELS

SNOW THROWER - MODEL NO. 1130STE (96191001906), PRODUCT NO. 961 91 00-19

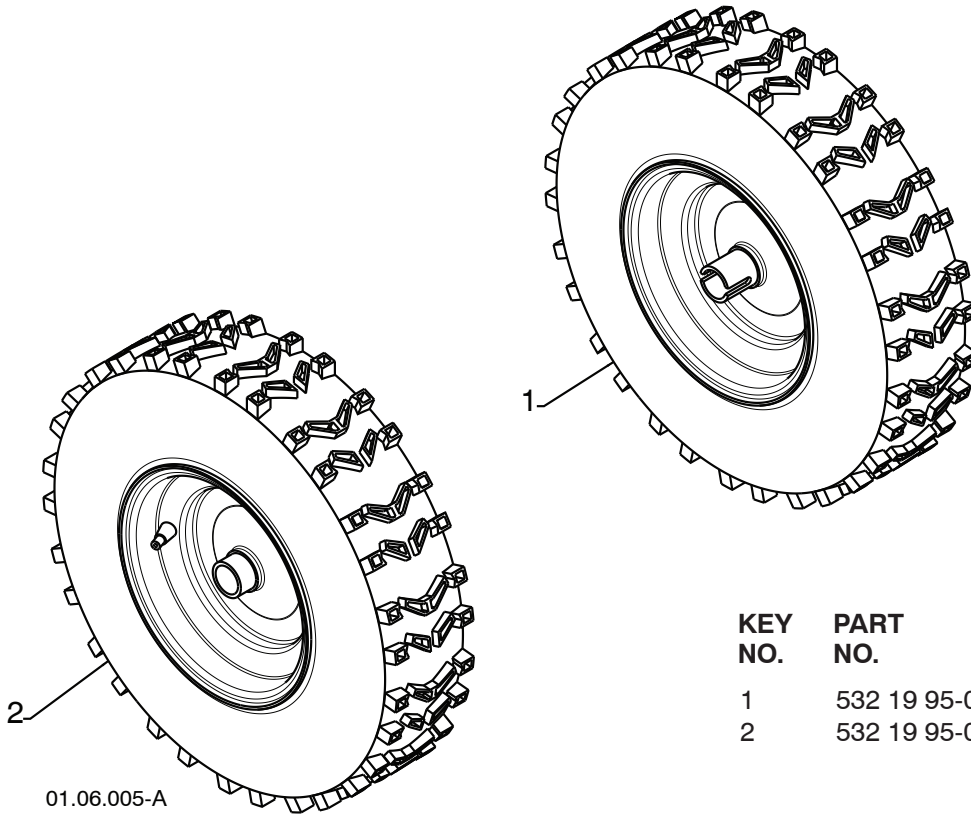

KEY NO.	PART NO.	DESCRIPTION
1	532 19 95-01	WHEEL 16 X 4.80 X LH
2	532 19 95-02	WHEEL 16 X 4.80 X RH

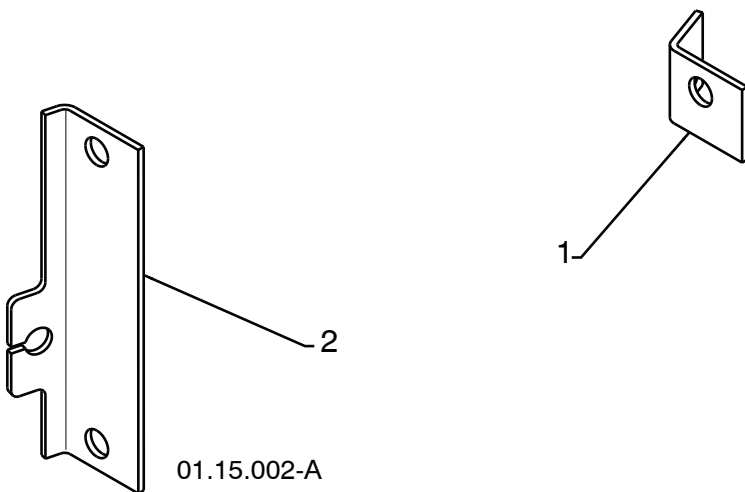

KEY NO.	PART NO.	DESCRIPTION
1	532 41 52-63	STEER CABLE BRACKET LH
2	532 18 78-59	STEER CABLE BRACKET RH

NOTE: All component dimensions given in U.S. inches. 1 inch = 25.4 mm
IMPORTANT: Use only Original Equipment Manufacturer (O.E.M.) replacement parts.
 Failure to do so could be hazardous, damage your snow thrower and void your warranty.

REPAIR PARTS

WHEELS

SNOW THROWER - MODEL NO. 1130STE (96191001906), PRODUCT NO. 961 91 00-19

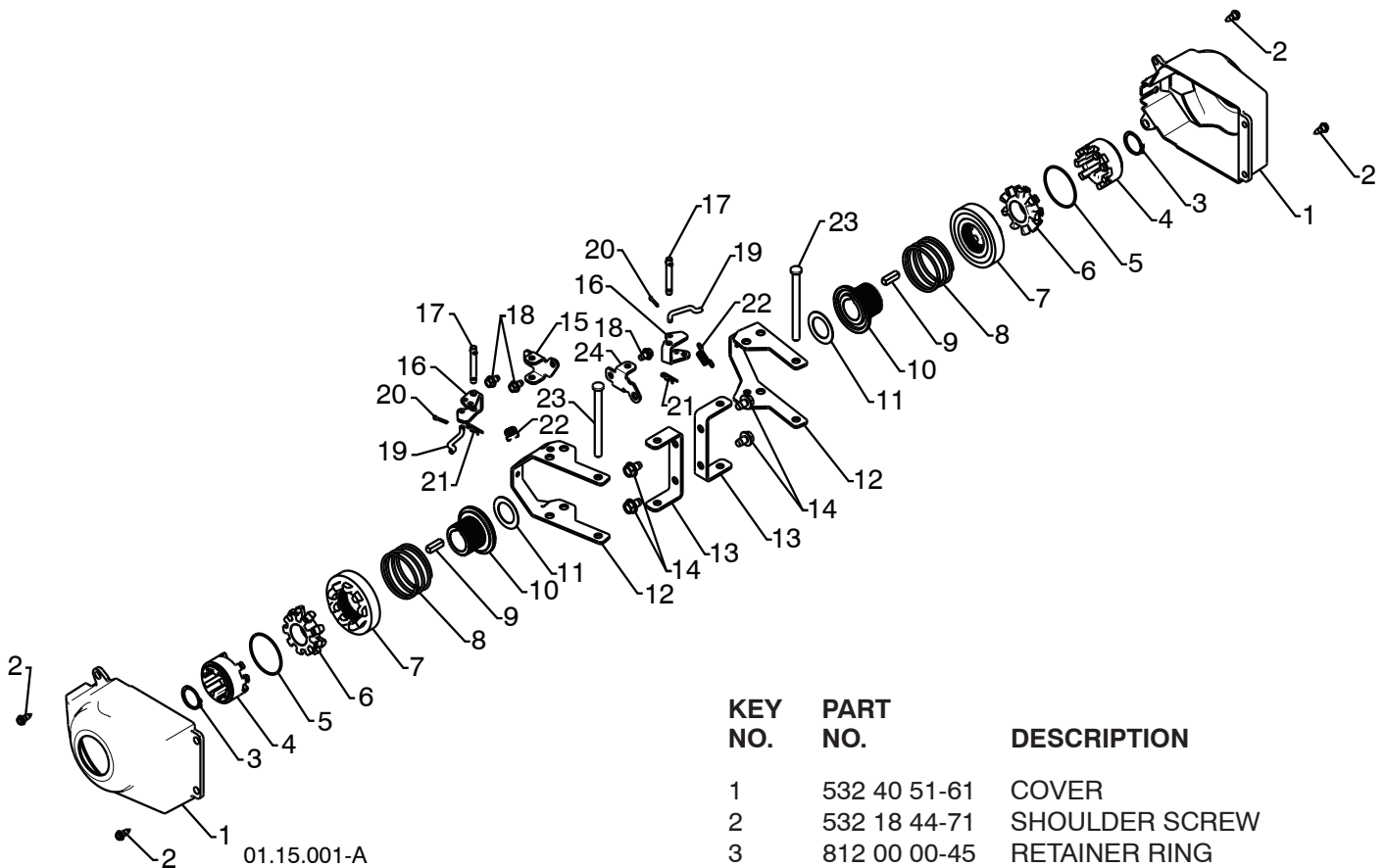

KEY NO.	PART NO.	DESCRIPTION
1	532 40 51-61	COVER
2	532 18 44-71	SHOULDER SCREW
3	812 00 00-45	RETAINER RING
4	532 19 21-26	WHEEL DRIVER
5	532 18 24-66	RETAINER RING
6	532 18 76-22	WHEEL LOBE
7	532 19 49-41	CLUTCH SLIDE
8	532 17 91-39	SPRING
9	532 18 92-82	SQUARE KEY
10	532 19 49-40	AXLE LOBE
11	532 17 46-97	THRUST WASHER
12	532 19 95-19	STEERING YOKE
13	532 18 41-97	STEERING BRACKET
14	817 49 05-08	SCREW 5/16-18 X .50
15	532 19 95-11	PIVOT BRACKET
16	532 19 95-18	BELLCRANK
17	532 18 18-47	BELLCRANK PIN
18	817 60 04-06	SCREW 1/4-20 X .375
19	532 40 50-77	STEERING LINK
20	532 70 02-79	RETAINER
21	532 08 51-79	RETAINER
22	532 19 38-85	SPRING
23	532 18 20-15	LEVER PIN
24	532 19 95-12	PIVOT BRACKET

NOTE: All component dimensions given in U.S. inches. 1 inch = 25.4 mm
IMPORTANT: Use only Original Equipment Manufacturer (O.E.M.) replacement parts.
 Failure to do so could be hazardous, damage your snow thrower and void your warranty.

REPAIR PARTS

BAG OF PARTS

SNOW THROWER - MODEL NO. 1130STE (96191001906), PRODUCT NO. 961 91 00-19

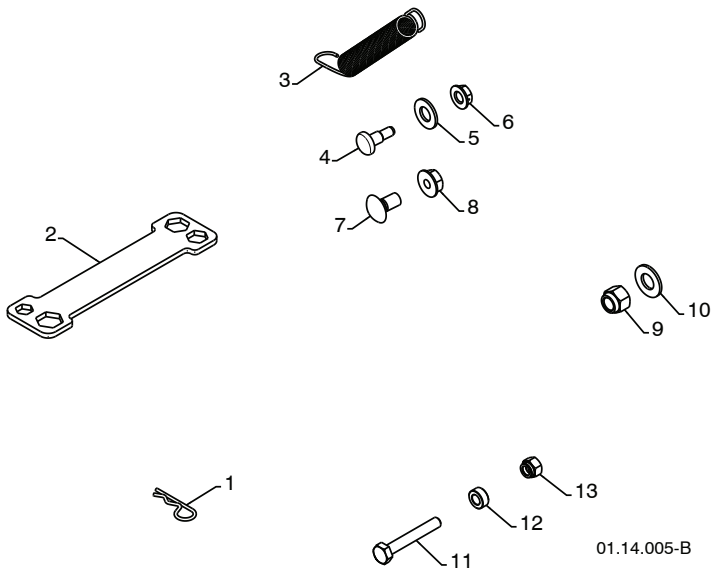

KEY NO.	PART NO.	DESCRIPTION
1	532 16 96-75	RETAINER PIN
2	532 18 06-84	WRENCH
3	532 18 45-05	REMOTE SPRING
4	532 17 98-29	SHOULDER BOLT 1/4-20
5	532 17 92-46	NYLON WASHER 1/4-20
6	532 19 17-30	LOCKNUT 1/4-20
7	872 25 05-05	CARRIAGE BOLT 5/16-18 X 5/8
8	532 75 11-53	LOCKNUT 5/16-18
9	873 80 06-00	LOCKNUT 3/8-16
10	819 13 13-16	WASHER 3/8
11	532 19 86-36	SHEAR BOLT 1/4-20 X 1-3/4
12	532 19 86-38	SPACER
13	873 80 04-00	LOCKNUT 1/4-20

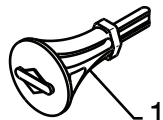

01.14.007-A

KEY NO.	PART NO.	DESCRIPTION
1	532 19 30-71	SAFETY IGNITION KEY

NOTE: All component dimensions given in U.S. inches. 1 inch = 25.4 mm
IMPORTANT: Use only Original Equipment Manufacturer (O.E.M.) replacement parts.
 Failure to do so could be hazardous, damage your snow thrower and void your warranty.

REPAIR PARTS

DECALS

SNOW THROWER - MODEL NO. 1130STE (96191001906), PRODUCT NO. 961 91 00-19

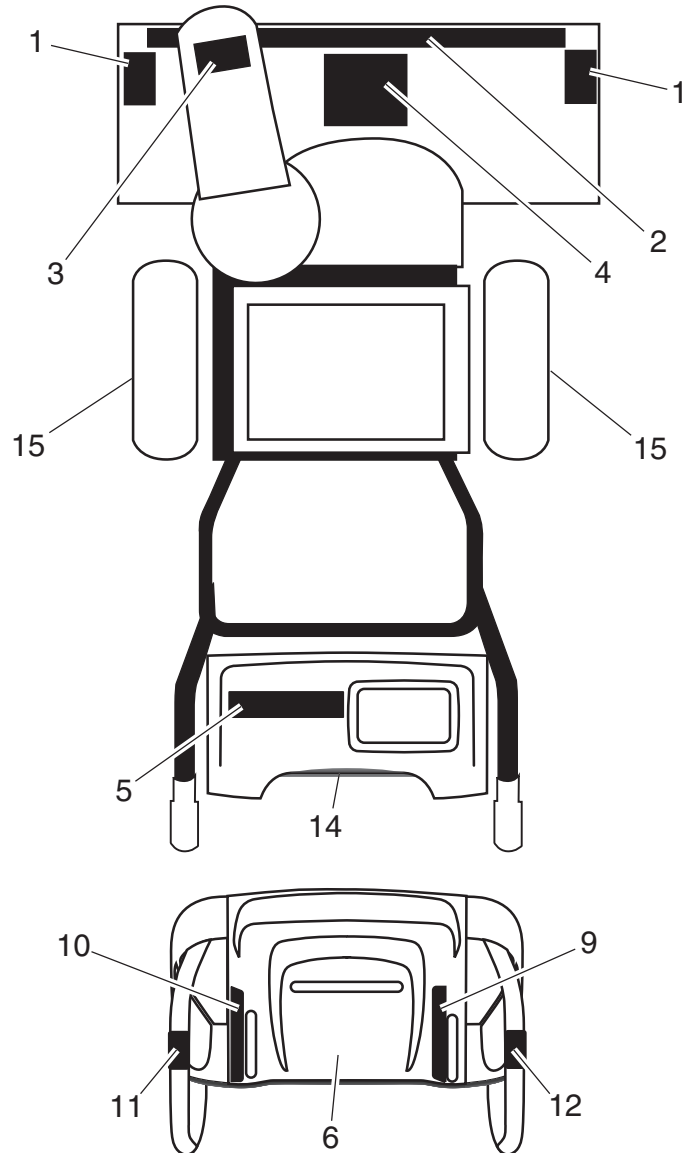

KEY PART NO.	PART NO.	DESCRIPTION	KEY PART NO.	PART NO.	DESCRIPTION
1	532 19 96-83	DECAL, DANGER	14	532 18 04-33	DECAL, SOUND LEVEL
2	532 42 10-58	DECAL, HUSQVARNA	15	532 18 40-28	DECAL, BELT GUARD
3	532 19 96-82	DECAL, DANGER, DEFLECTOR	--	532 41 40-23	OPERATOR'S MANUAL, EUROPEAN
4	532 18 40-45	DECAL, DANGER	--	532 41 40-24	OPERATOR'S MANUAL, SCANDINAVIAN
5	532 42 10-57	DECAL, HUSQVARNA, 1130STE	--	532 41 40-25	OPERATOR'S MANUAL, EAST BLOC
6	532 18 40-30	DECAL, INSTRUCTION	--	532 41 52-98	OPERATOR'S MANUAL, BALTIC
9	532 41 54-77	DECAL, SPEED CONTROL			
10	532 18 40-31	DECAL, REMOTE DEFLECTOR			
11	532 41 54-59	DECAL, LH TRIGGER			
12	532 41 54-60	DECAL, RH TRIGGER			

NOTE: All component dimensions given in U.S. inches. 1 inch = 25.4 mm
IMPORTANT: Use only Original Equipment Manufacturer (O.E.M.) replacement parts. Failure to do so could be hazardous, damage your snow thrower and void your warranty.