

CT131

Spare parts

Ersatzteile

Pièces détachées

Reserve onderdelen

Repuestos

Reservdelar

ILLUSTRATED PARTS LIST

MFG. ID NO. 96061022202

CUSTOMER CATALOG NO. CT131

PRODUCT NO. 960 61 02-22

47

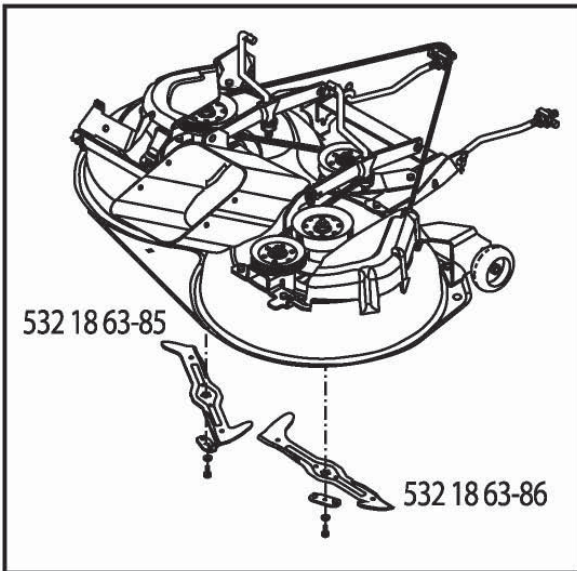
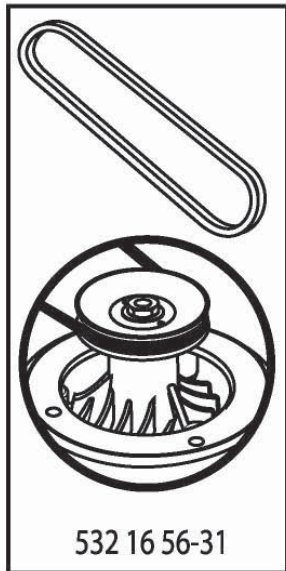
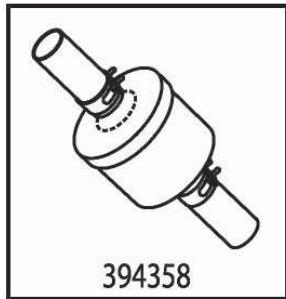
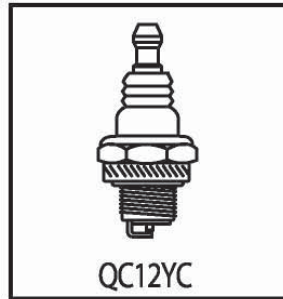
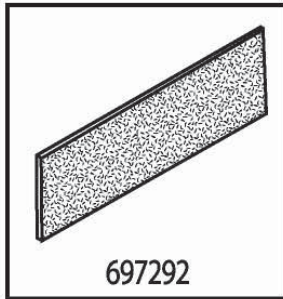
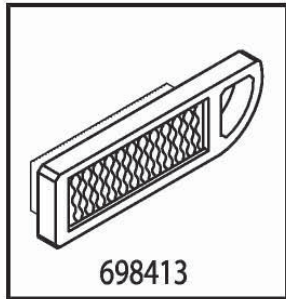

420815

**TRACTOR - - MODEL NO. CT131 (96061022202), PRODUCT NO. 960 61 02-22
DECALS 27**

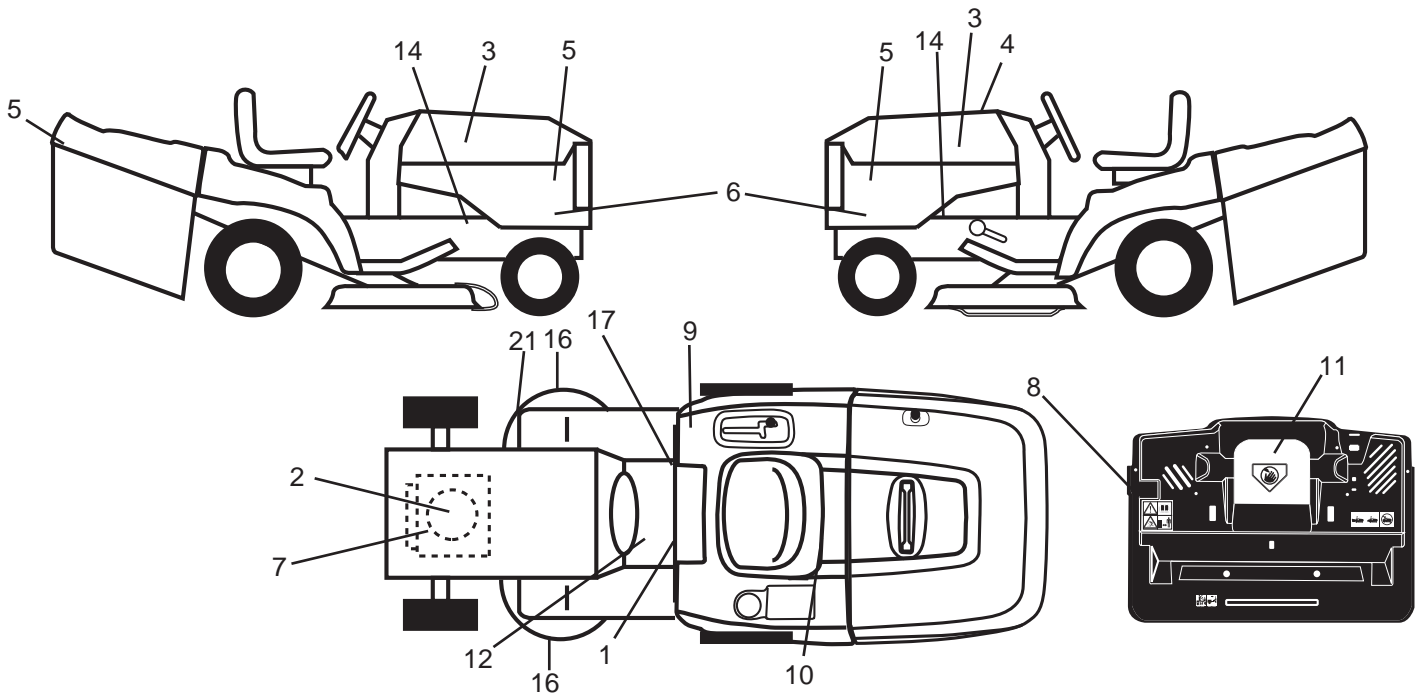

KEY NO.	PART NO.	DESCRIPTION
1	532 40 03-89	Decal, Warning Sym. CE
2	532 19 68-41	Decal, Warning Eng. Sym.
3	532 41 55-58	Decal, Hood
4	532 42 08-15	Decal, Replacement
5	532 40 22-12	Decal, Hood/CVR Logo
6	532 41 56-00	Decal, Panel SD
7	532 41 79-27	Decal, Engine HP
8	532 18 04-35	Decal, Rear Plate CRD Symbols
9	532 18 04-32	Decal, Fender 100 DB/CE
10	532 14 50-05	Decal, Bat Dan/Poi P/L Sym Wpn
11	532 18 21-66	Decal, Mower Cut Finger Symbol

KEY NO.	PART NO.	DESCRIPTION
12	532 15 97-37	Decal, Brake/Clutch Symbol Lt
14	532 15 97-36	Decal, Chassis Hot Muffler
16	532 19 68-42	Decal, Warning Cutfinger
17	532 14 08-37	Decal, Saddle Brake Parking
21	532 16 62-86	Decal, Hex Belt Sch 92 CRD
--	532 13 83-11	Decal, Lift Handle
--	532 41 55-73	Manual Operator's (Euro)
--	532 41 55-74	Manual Operator's (Scan)
--	532 41 55-75	Manual Operator's (E-Bloc)
--	532 41 55-76	Manual Operator's (Baltic)

WHEELS & TIRES

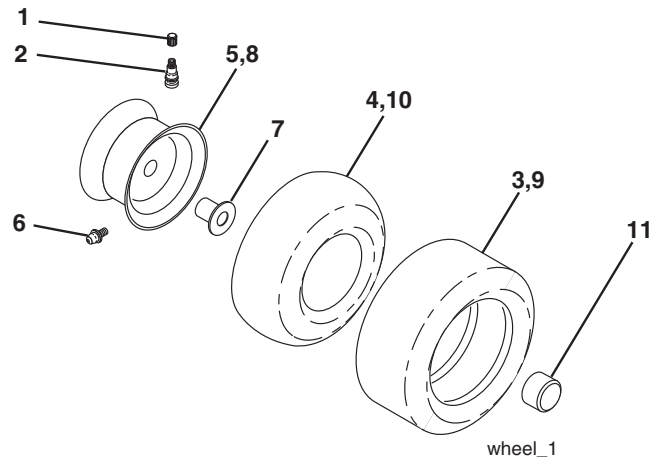

KEY NO.	PART NO.	DESCRIPTION
1	532 05 91-92	Cap Valve Tire
2	532 06 51-39	Stem Valve
3	532 12 41-57	Tire F Ts 15 x 6 0 - 6 Service
4	532 05 99-04	Tube Inner Front #35060
5	532 13 83-36	Rim Asm 6" Front Silver Service
6	532 12 49-57	Fitting Grease
7	532 12 49-59	Bearing Flange
8	532 13 83-37	Rim Asm 8" Rear Silver Service
9	532 12 39-69	Tire R Ts 18 x 8.5-8 Service
10	532 12 49-26	Tube Rear 9 5 x 8 Service
11	532 17 50-39	Cap Axle Blk 1 50 x 1 00
--	532 14 43-34	Sealant, Tire (10 oz. tube)

NOTE: All component dimensions given in U.S. inches
1 inch = 25.4 mm

TRACTOR - - MODEL NO. CT131 (96061022202), PRODUCT NO. 960 61 02-22 SCHEMATIC 38

SCH08

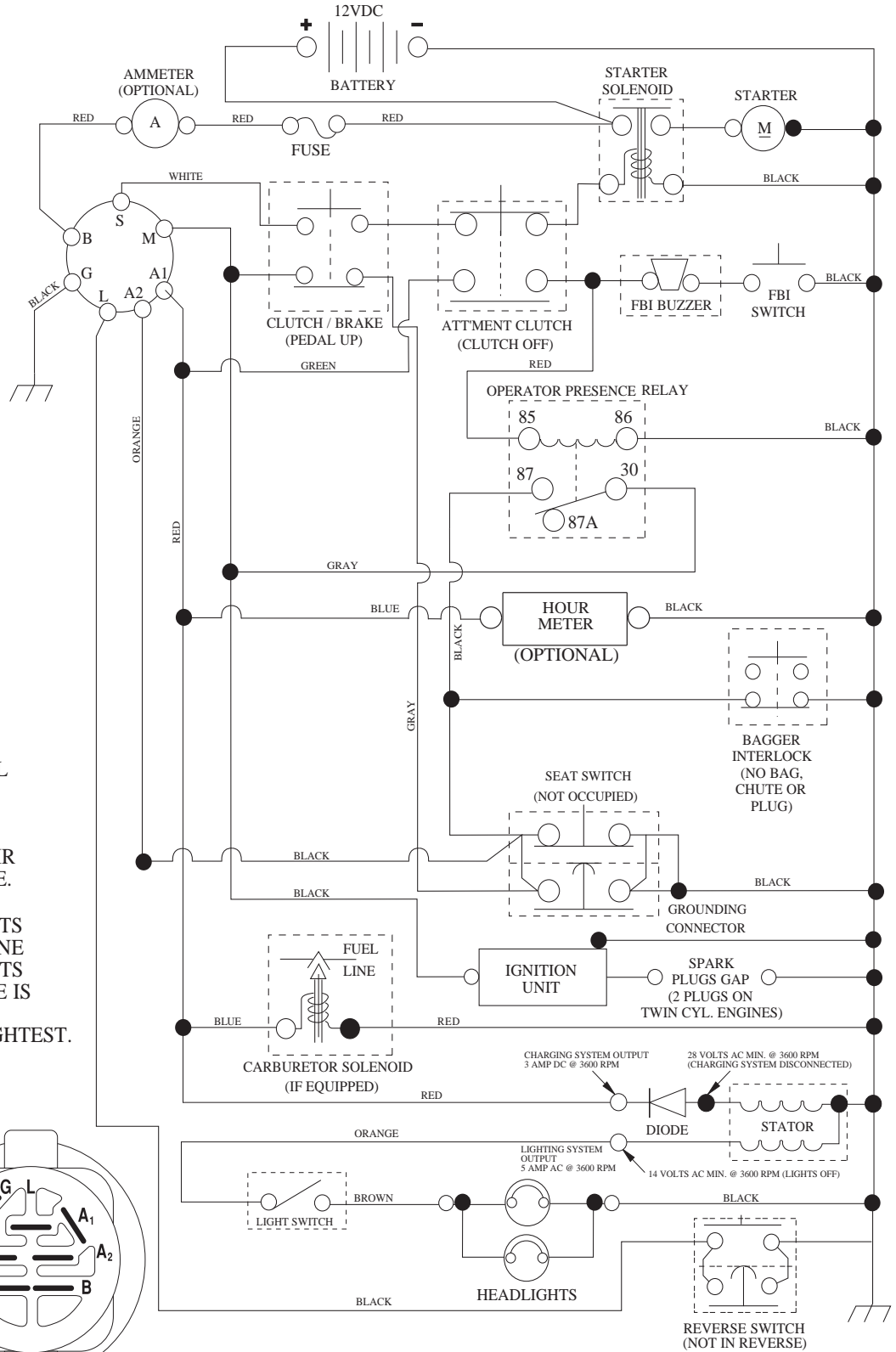

NOTE
YOUR TRACTOR IS EQUIPPED WITH A SPECIAL ALTERNATOR SYSTEM. THE LIGHTS ARE NOT CONNECTED TO THE BATTERY, BUT HAVE THEIR OWN ELECTRICAL SOURCE. BECAUSE OF THIS, THE BRIGHTNESS OF THE LIGHTS WILL CHANGE WITH ENGINE SPEED. AT IDLE THE LIGHTS WILL DIM. AS THE ENGINE IS SPEEDED UP, THE LIGHTS WILL BECOME THEIR BRIGHTEST.

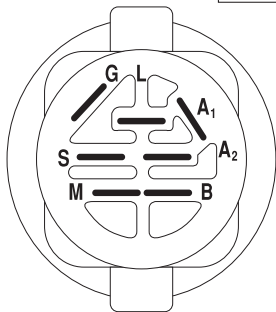

IGNITION SWITCH

POSITION	CIRCUIT	"MAKE"
OFF	M+G+A1	
RUN/OVERRIDE	B+A1	
RUN	B+A1	L+A2
START	B + S + A1	

WIRING INSULATED CLIPS
NOTE: IF WIRING INSULATED CLIPS WERE REMOVED FOR SERVICING OF UNIT, THEY SHOULD BE RE-INSTALLED TO PROPERLY SECURE YOUR WIRING.

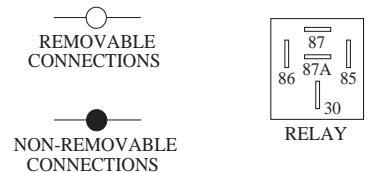

TRACTOR - - MODEL NO. CT131 (96061022202), PRODUCT NO. 960 61 02-22
 ELECTRICAL **32**

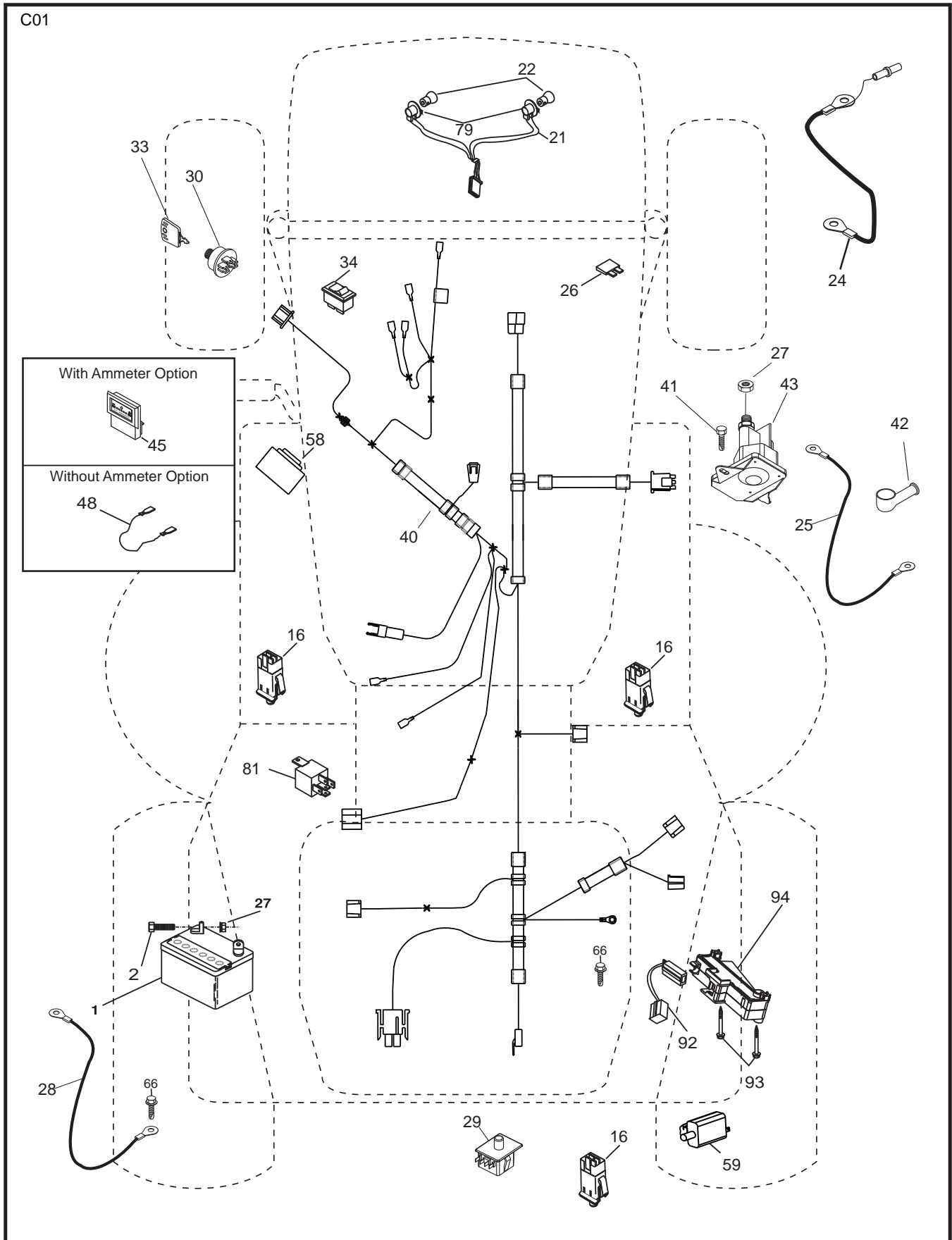

**TRACTOR - - MODEL NO. CT131 (96061022202), PRODUCT NO. 960 61 02-22
ELECTRICAL 32**

KEY NO.	PART NO.	DESCRIPTION
1	532 16 34-65	Battery
2	874 76 04-12	Bolt Hex Hd 1/4-20 unc x 3/4
16	532 17 61-38	Switch Interlock
21	532 17 56-88	Harness Asm Light w/4152J
22	532 00 41-52	Bulb Light #1156
24	532 12 47-80	Cable Starter
25	532 16 59-87	Cable Battery CRD 56" Red
26	532 17 51-58	Fuse
27	873 51 04-00	Nut Keps Hex 1/4-20 unc
28	532 12 77-25	Cable Ground 6 Ga. 18" Black
29	532 19 27-49	Switch Seat
30	532 19 33-50	Switch Ignition
33	532 41 19-35	Key/Chain
34	532 11 07-12	Switch Light
40	532 19 74-36	Harness Ignition
41	871 11 04-08	Bolt Flk Fin Hex 1/4-20 unc x 1/2
42	532 13 15-63	Cover Terminal Red
43	532 19 25-07	Solenoid
48	532 14 08-44	Adapter Ammeter Rectangular
58	532 16 94-19	Buzzer Crd
59	532 18 03-79	Switch FBI CRD
66	817 49 06-08	Screw Thdrol 3/8-16 x 1/2 Ty-Tt
79	532 17 52-42	Socket Asm. Bulb
81	532 10 97-48	Relay Asm
92	532 19 66-15	Harness Pigtail
93	532 19 25-40	Screw Plastite 10-14 x 2.0
94	532 19 18-34	Module Reverse

NOTE: All component dimensions given in U.S. inches
1 inch = 25.4 mm

**TRACTOR - - MODEL NO. CT131 (96061022202), PRODUCT NO. 960 61 02-22
CHASSIS AND ENCLOSURES 39**

KEY NO.	PART NO.	DESCRIPTION	KEY NO.	PART NO.	DESCRIPTION
1	532 17 46-20	Chassis	164	532 16 56-05	Support Battery CRD
2	532 18 03-84	Drawbar	165	532 18 13-56	Cover Battery
3	817 06 06-12	Screw 3/8-16 x 3/4	170	532 19 94-88	Backplate Asm CRD
5	532 15 52-72	Bumper Hood/Dash	171	872 14 06-20	Bolt Rdhd Sqnk 3/8-16 x 2-1/2 Gr. 5
6	532 18 44-19	Saddle	172	819 13 20-16	Washer 13/32 x 1-1/4 x 16 Ga.
8	532 12 64-71	Clip Insulator 13/32 Mtg. Hole	173	873 51 06-00	Nut, Keps Hex 3/8-16 unc
9	532 19 46-88	Dash	175	532 18 82-03	Guard Trap
10	872 14 06-08	Bolt, Carriage 3/8-16 x 3/4	179	532 18 82-02	Rod Pivot FBI CRD
11	532 17 49-96	Panel, Dash, LH	184	532 17 46-62	Bracket Actuator Bagger CRD
13	532 17 21-06	Panel, Asm. Dash RH	185	532 18 11-01	Knob Rod Brake Parking
15	874 18 05-12	Screw, Machine, Truss Head 5/16-18 unc x 3/4	186	532 16 07-93	Latch Asm Mulch/Bagger
16	873 51 05-00	Nut	187	532 12 50-04	Nut Weld
17	532 18 88-93	Hood	188	819 06 12-16	Washer #10
18	532 18 49-21	Bumper Hood	189	810 07 10-00	Washer Lock #10
24	874 78 06-16	Bolt	190	871 08 10-10	Screw Pan Hd Phillip 10-24 x 5/8
25	819 13 13-12	Washer 13/32 x 13/16 x 12 Ga.	198	532 16 89-37	Nut, Push
26	873 80 06-00	Nut	205	817 49 06-08	Screw Thdrol 3/8-16 x 1/2
28	532 18 35-38	Grille/Lens Asm (Key #s 258, 259, 261, 212, 260)	207	817 67 05-08	Screw 5/16-18 x 1/2
30	532 19 73-76	Fender	208	817 67 06-08	Screw Thdrol 3/8-16 x 1/2
31	532 16 51-56	Bracket, Fender Support	209	817 00 06-12	Screw Hex Wsh Thdrol 3/8-16
33	532 17 97-16	Footrest, LH	212	532 18 35-48	Insert Lens RFLCT
34	532 17 97-17	Footrest, RH	256	532 18 13-61	Cover Fender
35	872 11 06-06	Bolt	258	532 18 52-14	Lens Grille RH
37	817 49 05-08	Screw Thdrol 5/16-18 x 1/2 TYT	259	532 18 52-13	Lens Grille LH
38	532 18 17-48	Bracket Asm Pivot Mower Rear	260	532 18 52-16	Cover Lens
39	532 40 78-07	Bracket Pivot	261	532 18 52-12	Insert Grille
58	532 18 42-70	Duct Air	265	532 18 57-04	Seal RH Side Bagger
69	532 14 24-32	Screw Hex 1/4-1/2 unc	266	532 18 57-03	Seal LH Side Bagger
89	532 19 73-39	Console	272	532 18 88-96	Vent Hood RH
145	532 40 91-67	Rod Pivot Chassis/Hood	273	532 18 88-95	Vent Hood LH
162	532 18 03-82	Bracket Exten Chassis LH CRD	278	532 41 63-58	Screw #10 x 0.750
163	532 18 03-83	Bracket Exten Chassis RH CRD			

NOTE: All component dimensions given in U.S. inches.
1 inch = 25.4 mm.

TRACTOR - - MODEL NO. CT131 (96061022202), PRODUCT NO. 960 61 02-22
DRIVE **40**

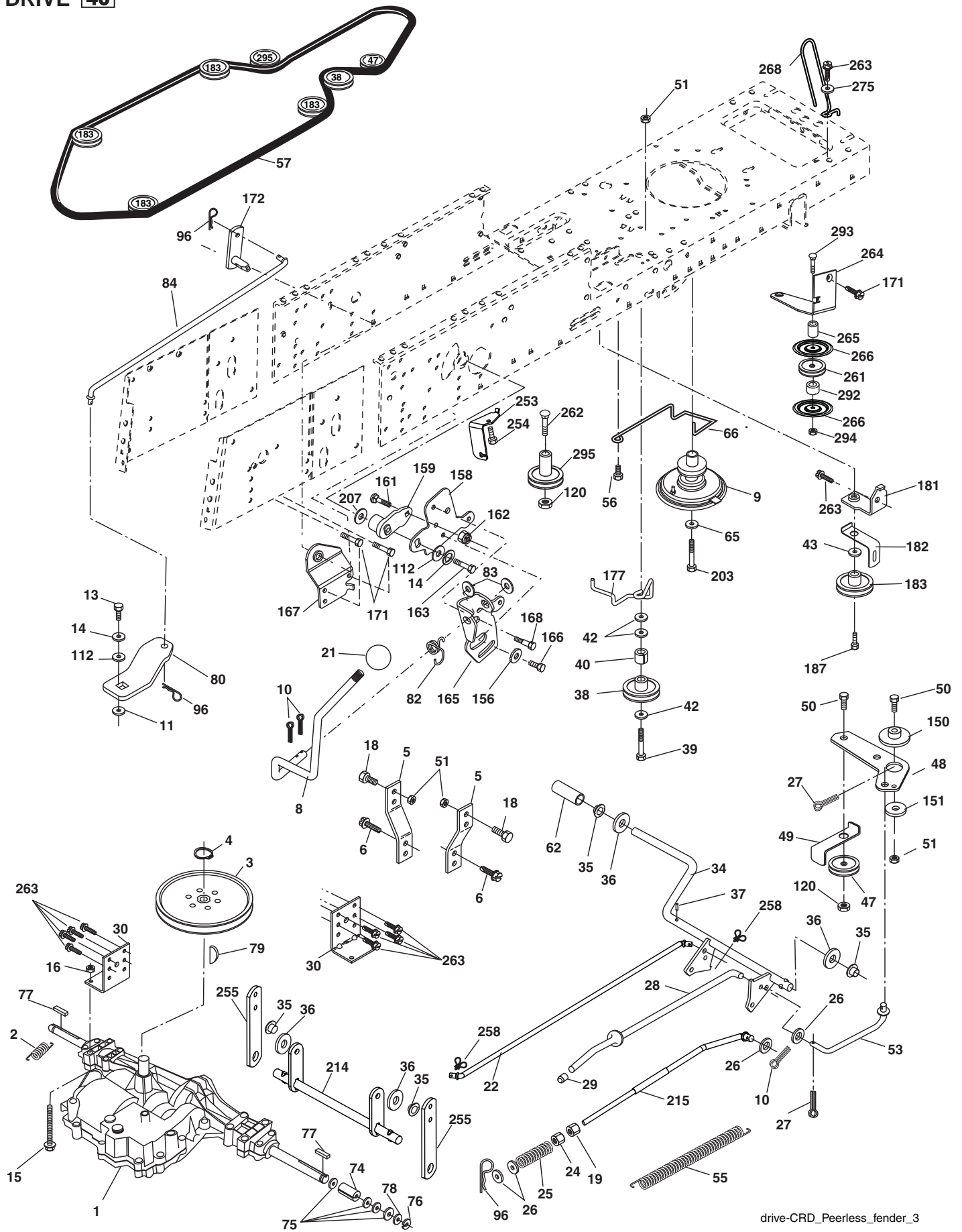

drive-CRD_Peerless_fender_3

**TRACTOR - - MODEL NO. CT131 (96061022202), PRODUCT NO. 960 61 02-22
DRIVE 40**

KEY NO.	PART NO.	DESCRIPTION	KEY NO.	PART NO.	DESCRIPTION
1	-----	Transaxle Peerless 206-546	79	532 12 50-96	Key Woodruff
2	532 14 66-82	Spring Brake Return	80	532 14 50-90	Arm Shift PMST 20" Tires
3	532 16 59-99	Pulley Transaxle	82	532 16 57-11	Spring, Torsion
4	812 00 00-28	Ring Retainer #5100-62	83	819 17 12-16	Washer 17/32 x 3/4 x 16 Ga.
5	532 12 15-20	Strap Torque 30 Degrees	84	532 16 56-21	Link Shift CRD Pmst 18" Tires
6	817 06 05-12	Screw 5/16-18 x 3/4	96	532 12 47-88	Spring, Retainer 1"
8	532 19 27-06	Rod Shift	112	819 09 12-10	Washer 9/32 x 3/4 x 10 Ga.
9	532 40 85-79	Clutch Noram	120	873 90 06-00	Nut Lock Flg. 3/8-16 unc
10	876 02 04-16	Pin, Cotter 1/8 x 1	150	532 16 58-50	Bushing, Bellcrank Grnd Dr
11	532 10 57-01	Washer Plate Shf .3888 Sq Hole	151	819 13 32-10	Washer 13/32 x 2 x 10 Ga.
13	874 55 04-12	Bolt 1/4-28 unf Gr. 8 w/Patch	156	532 16 60-02	Washer Srrd 5/16 ID x 1.125
14	810 04 04-00	Washer, Lock Hvy Helical	158	532 16 55-89	Bracket Shift Mount
15	874 49 05-44	Bolt Hex Flghd 5/16-18 Gr. 5	159	532 18 39-00	Hub Shift
16	873 80 05-00	Nut, Lock Hex w/Ins 5/16-18 unc	161	872 14 04-06	Bolt Rdhd Sqnk 1/4-20 x 3/4 Gr. 5
18	874 78 06-16	Bolt Hex 3/8-16 unc x 1 Gr. 5	162	873 68 04-00	Nut Crownlock 1/4-20 unc
19	873 80 06-00	Nut, Lock Hex w/Wsh 3/8-16 unc	163	874 78 04-16	Bolt Hex Fin 1/4-20 unc x 1 Gr. 5
21	532 10 69-33	Knob	165	532 16 56-23	Bracket Pivot Lever
22	532 17 56-07	Rod, Brake CRD	166	817 49 05-10	Screw 5/16-18 x 5/8
24	873 35 06-00	Nut	167	532 16 55-88	Bracket Support Shift CRD
25	532 10 68-88	Spring, Rod, Brake	168	532 16 54-92	Bolt Shoulder 5/16-18 x .561
26	819 13 13-16	Washer 13/32 x 13/16 x 16 Ga.	171	817 49 06-08	Screw Thdrol 3/8-16 x 1/2 Ty-Tt
27	876 02 04-12	Pin, Cotter 1/8 x 3/4	172	532 16 56-35	Shaft Asm Shift Front CRD PMST
28	532 17 57-65	Rod, Parking Brake	177	532 16 59-32	Keeper Flat Idler 3.06" CRD
29	532 07 16-73	Cap Brake Parking	181	532 18 02-11	Bracket Idler Ground Drive CRD
30	532 17 49-73	Bracket, Mfg. Transaxle	182	532 18 26-82	Keeper Belt 2.5" Od V-Idler CRD
34	532 17 55-78	Shaft, Asm Pedal Foot	183	532 19 95-32	Pulley V-Idler
35	532 12 01-83	Bearing, Nylon	187	817 58 05-20	Screw 5/16-18 x 1.25
36	819 21 16-16	Washer 21/32 x 1 x 16 Ga.	203	871 17 07-80	Bolt Hex 7/16-20 x 5
37	532 12 49-63	Pin, Roll 3/16 x 1"	207	532 16 98-45	Washer Nylon Rear
38	532 16 59-36	Pulley, Flat	214	532 17 56-09	Shaft Asm Blade
39	874 76 06-44	Bolt Fin Hex 3/8-16 unc x 2-3/4	215	532 41 01-42	Rod Brake
40	532 12 49-65	Spacer, Split 395 x 59 Bzp	253	532 17 50-28	Bracket Cable Chassis
42	819 13 13-12	Washer 13/32 x 13/16 x 12 Ga.	254	817 00 06-16	Screw 3/8-16 x 1
43	819 11 10-12	Washer 11/32 x 5/8 x 12 Ga.	255	532 17 56-08	Brace Shaft Brake Mtg.
47	532 12 77-83	Pulley, Idler, V Groove Plastic	258	532 17 80-62	Clip Retainer
48	532 15 44-07	Bellcrank Clutch Grnd Drv	261	532 13 14-94	Pulley Idler
49	532 12 32-05	Retainer, Belt Style Spring	263	817 00 06-12	Screw 3/8-16 x 3/4
50	872 11 06-12	Bolt 3/8-16 unc x 1-1/2	262	872 11 06-22	Bolt Rdhd 3/8-16 unc x 2-3/4 Gr. 5
51	873 68 06-00	Nut, Crownlock 3/8-16 unc	264	532 19 76-08	Bracket Idler
53	532 19 96-52	Link, Clutch 7.66	265	532 40 46-07	Spacer Idler Chassis
55	532 10 57-09	Spring, Return, Clutch	266	532 18 20-61	Shield Idler Mower
56	817 06 06-20	Screw 3/8-16 x 1-1/4	268	532 18 24-02	Guard Muffler RH
57	532 16 56-31	V-Belt Drive	275	819 13 16-14	Washer 13/32 x 1 x 14 Ga.
62	532 12 48-72	Cover, Pedal	292	532 40 02-71	Spacer
65	810 04 07-00	Washer	293	872 14 06-28	Bolt Rdhd Sqnk 3/8-16 x 3-1/2
66	532 15 47-78	Keeper, Belt Engine F-Proof	294	532 19 70-33	Nut Jam 3/8-16
74	532 13 70-57	Spacer Axle	295	532 17 91-14	Pulley Idler
75	532 12 17-49	Washer 25/32 x 1-1/4 x 16 Ga.			
76	812 00 00-01	Ring, E			
77	532 12 35-83	Key, Square			
78	532 12 17-48	Washer 25/32 x 1-5/8 x 16 Ga.			

NOTE: All component dimensions given in U.S. inches.
1 inch = 25.4 mm.

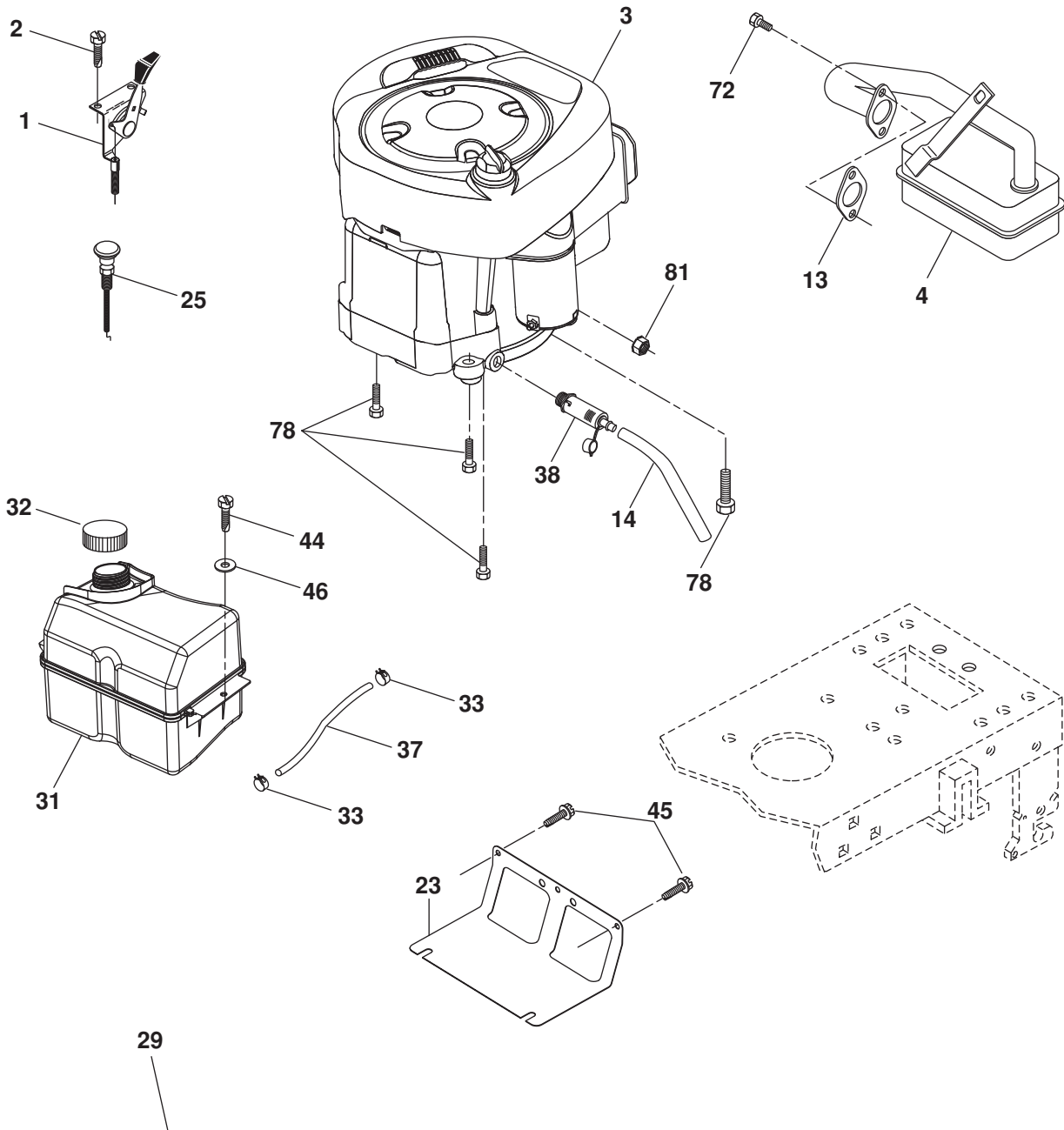

OPTIONAL EQUIPMENT
Spark Arrester

engine-bs.1cyl_65

**TRACTOR - - MODEL NO. CT131 (96061022202), PRODUCT NO. 960 61 02-22
ENGINE 24**

KEY NO.	PART NO.	DESCRIPTION
1	532 17 05-51	Control Throt/Ck
2	817 72 04-08	Screw Hex Thd Cut 1/4-20 x 1/2
3	-----	Engine Briggs Model 219807
4	532 17 97-58	Muffler
13	532 16 52-91	Gasket Muffler
14	532 14 84-56	Tube Drain Oil Easy
23	532 16 98-37	Shield Brn/Dbr Guard
25	532 19 06-95	Control Choke
29	532 13 71-80	Kit Spark Arrester (Flat Scrn)
31	532 40 75-51	Tank Fuel 2.00
32	532 19 77-25	Cap Asm Fuel
33	532 12 34-87	Clamp Hose Blk
37	532 13 70-40	Line Fuel
38	532 18 16-54	Plug Drain Oil Easy
44	817 67 04-12	Screw Hexwsh thdrol 1/4-20 x 3/4
45	817 00 06-12	Screw Hexwsh Thdr 3/8-16 x 3/4
46	819 09 14-16	Washer 9/32 x 7/8 x 16 Ga.
72	532 19 23-34	Screw 5/16-18 x .75
78	817 06 06-20	Screw 3/8-16 x 1-1/4
81	873 51-04-00	Nut Keps Hex 1/4-20 unc

NOTE: All component dimensions given in U.S. inches
1 inch = 25.4 mm

Engine Power Rating Information

The gross power rating for individual gas engine models is labeled in accordance with SAE (Society of Automotive Engineers) code J1940 (Small Engine Power & Torque Rating Procedure), and rating performance has been obtained and corrected in accordance with SAE J1995 (Revision 2002-05). Torque values are derived at 3060 RPM; horsepower values are derived at 3600 RPM. Actual gross engine power will be lower and is affected by, among other things, ambient operating conditions and engine-to-engine variability. Given both the wide array of products on which engines are placed and the variety of environmental issues applicable to operating the equipment, the gas engine will not develop the rated gross power when used in a given piece of power equipment (actual "on-site" or net power). This difference is due to a variety of factors including, but not limited to, accessories (air cleaner, exhaust, charging, cooling, carburetor, fuel pump, etc.), application limitations, ambient operating conditions (temperature, humidity, altitude), and engine-to-engine variability. Due to manufacturing and capacity limitations, Briggs & Stratton may substitute an engine of higher rated power for this Series engine.

TRACTOR - - MODEL NO. CT131 (96061022202), PRODUCT NO. 960 61 02-22
 STEERING ASSEMBLY **41**

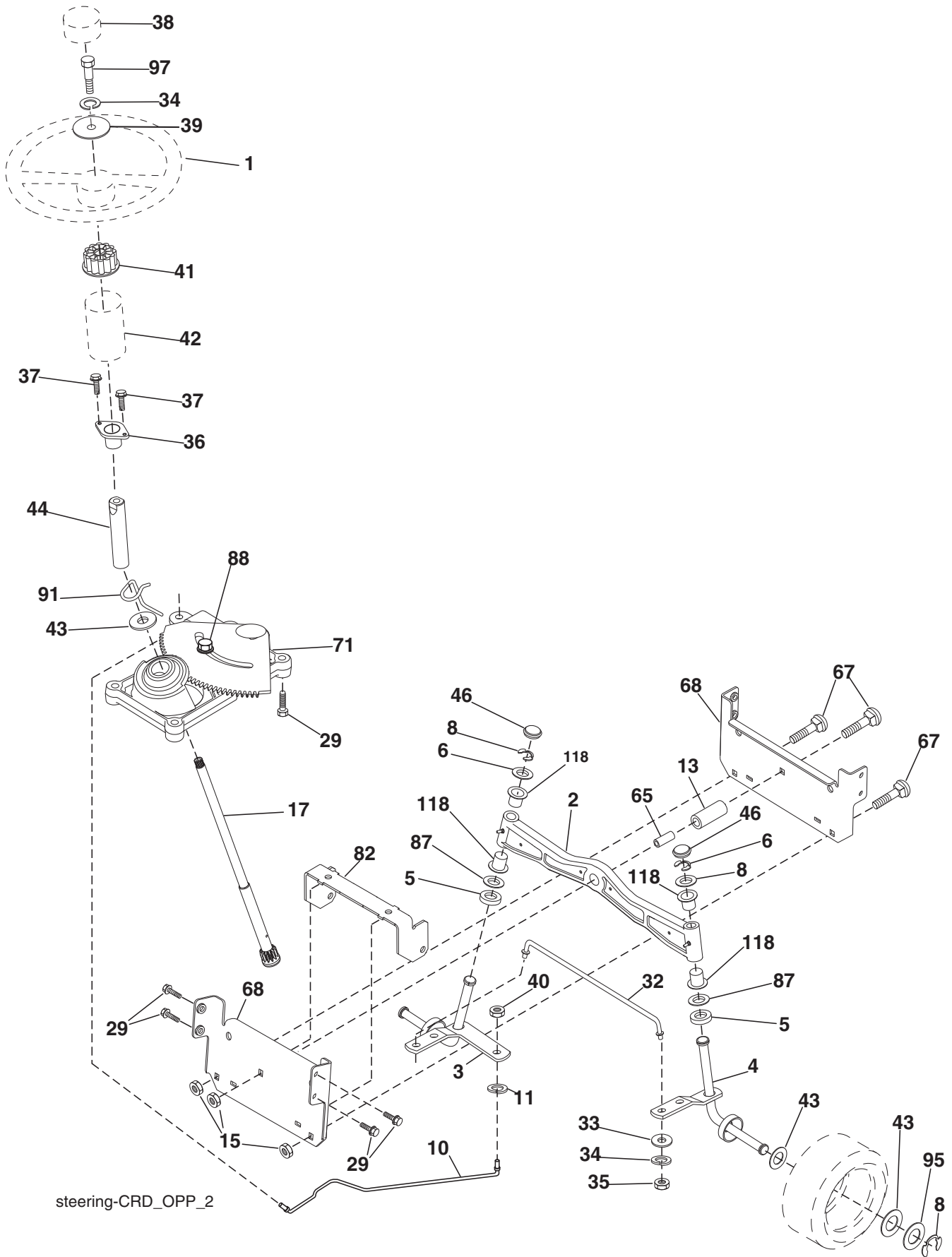

steering-CRD_OPP_2

**TRACTOR - - MODEL NO. CT131 (96061022202), PRODUCT NO. 960 61 02-22
STEERING ASSEMBLY **41****

KEY NO.	PART NO.	DESCRIPTION
1	532 18 67-80	Steering Wheel
2	532 19 35-42	Front Axle Assembly
3	532 16 98-40	Spindle Assembly, LH
4	532 16 98-39	Spindle Assembly, RH
5	532 12 49-31	Washer, Thrust .75 x 1.230
6	532 12 17-48	Washer 25/32 x 1-5/8 x 16 Ga.
8	812 00 00-29	Ring, Klip
10	532 17 51-21	Link, Drag
11	810 04 06-00	Washer, Lock
13	532 13 65-18	Spacer Axle
15	532 14 52-12	Nut Hex Flange Lock
17	532 19 07-53	Shaft Assembly, Steering
29	817 00 06-12	Screw 3/8-16 x 3/4
32	532 17 01-62	Rod, Tie
33	819 11 12-16	Washer 11/32 x 3/4 x 16 Ga.
34	810 04 05-00	Washer Lock Hvy Hlcl Spr 5/16
35	873 54 05-00	Crownlock Nut 5/16-24 unf
36	532 15 50-99	Bushing, Steering
37	532 15 29-27	Screw TT #10-32 x 5 x 3/8 Flange
38	532 19 29-16	Cap Wheel Steering
39	819 11 38-12	Washer 11/32 ID x 2 3/8 OD x 12 Ga.
40	873 54 06-00	Nut Crownlock 3/8-24 unf
41	532 18 67-37	Adaptor, Steering Wheel
42	532 16 96-33	Boot, Steering
43	532 12 17-49	Washer 25/32 x 1-1/4 x 16 Ga.
44	532 19 07-52	Extension Steering
46	532 12 12-32	Cap, Spindle
65	532 41 47-36	Spacer Axle
67	872 11 06-18	Bolt Rdhd Sq 3/8-16 x 2-1/4
68	532 16 98-27	Brace Axle
71	532 17 51-46	Steering Asm.
82	532 19 99-78	Bracket Susp. Chassis Front
87	532 17 39-66	Washer Flat .781 x 1-1/2 x .14
88	532 17 51-18	Bolt Shoulder 7/16-20 unc
91	532 17 55-53	Clip Steering
95	532 18 89-67	Washer
97	874 78 05-64	Bolt 5/16-18 unc x 4" L Gr. 5
118	532 40 60-13	Bushing

NOTE: All component dimensions given in U.S. inches
1 inch = 25.4 mm

TRACTOR - - MODEL NO. CT131 (96061022202), PRODUCT NO. 960 61 02-22
SEAT ASSEMBLY 42

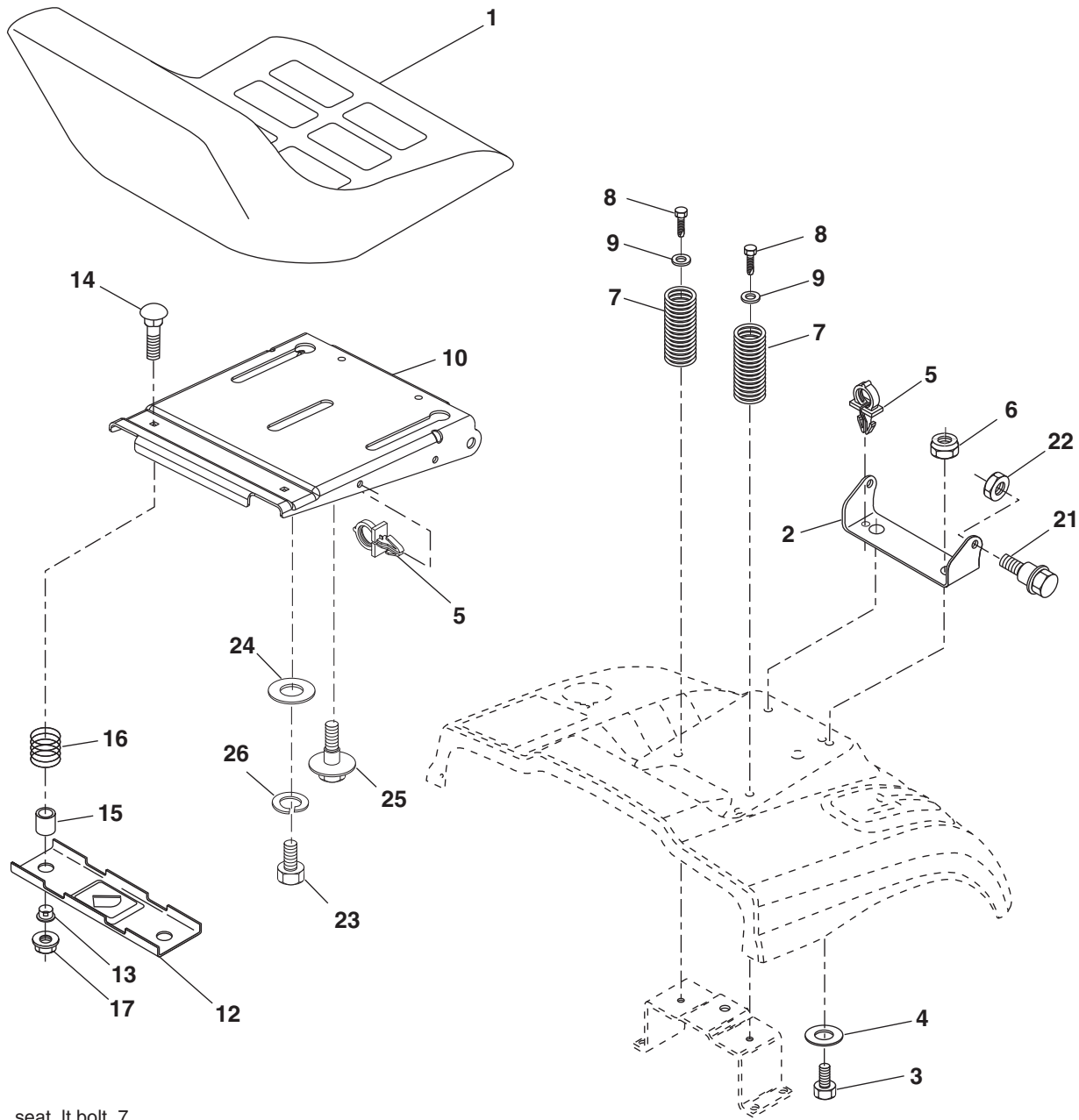

seat_lt.bolt_7

KEY NO.	PART NO.	DESCRIPTION
1	532 40 10-42	Seat
2	532 14 05-51	Bracket Pnt Pivot Fender
3	871 11 06-16	Bolt Fin Hex 3/8-16 x 1
4	819 13 16-10	Washer Flat 13/32 x 1 x 10 Ga.
5	532 14 50-06	Clip Push In Hinged
6	873 80 06-00	Nut Lock Hex w/Ins 3/8-16
7	532 12 41-81	Spring Seat Cprsn 2 250 Blk Zi
8	817 00 06-16	Screw 3/8-16 x 1.5
9	819 13 16-14	Washer 13/32 x 1 x 14 Ga.
10	532 19 55-30	Pan Pnt Seat
12	532 17 46 48	Bracket Pnt Mounting Switch
13	532 12 12-48	Bushing Snap Blk Nyl 50 Id
14	872 05 04-12	Bolt Rdhd Sht Nk 1/4-20 x 1-1/2

KEY NO.	PART NO.	DESCRIPTION
15	532 13 43-00	Spacer Split
16	532 12 12-50	Spring Cprsn
17	532 12 39-76	Nut Lock 1/4 Lge Flg Gr. 5 Zinc
21	532 17 18-52	Bolt Shoulder 5/16-18 unc-2A
22	873 80 05-00	Nut Hex Lock w/Ins 5/16-18
23	871 11 08-14	Bolt Hex
24	819 17 19-12	Washer 17/32 x 1-3/16 x 12 Ga.
25	532 12 70-18	Bolt Shoulder 5/16-18 x .62
26	810 04 08-00	Washer Lock 1/2

NOTE: All component dimensions given in U.S. inches
 1 inch = 25.4 mm

**TRACTOR - - MODEL NO. CT131 (96061022202), PRODUCT NO. 960 61 02-22
BAGGER [46]**

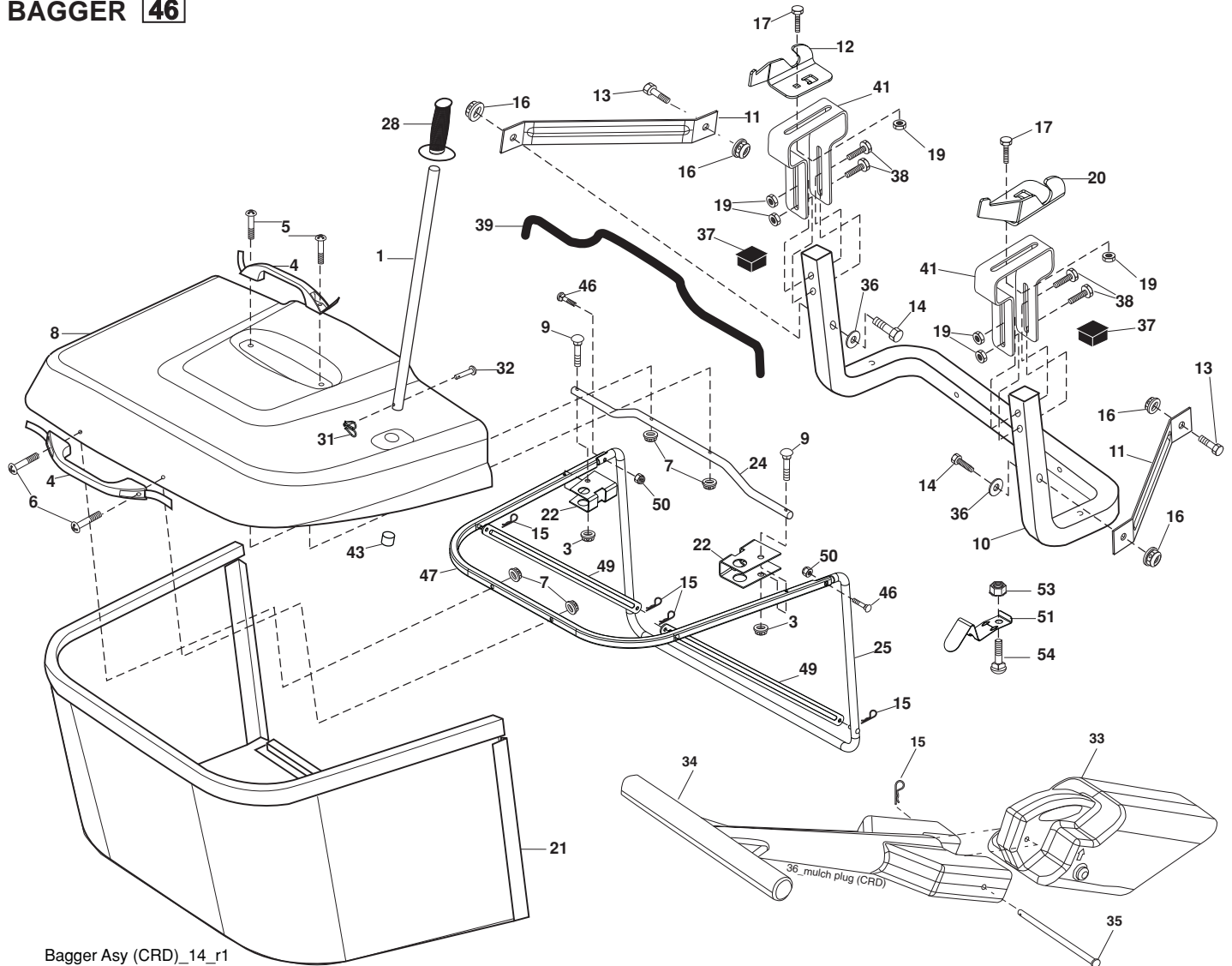

Bagger Asy (CRD)_14_r1

KEY NO.	PART NO.	DESCRIPTION	KEY NO.	PART NO.	DESCRIPTION
1	532 16 52-49	Tube Handle Bagger CRD	28	532 16 57-87	Grip Handle
3	532 12 39-76	Nut Lock 1/4 Lge Flg Gr. 5 Zinc	31	532 16 94-84	Retainer Clip
4	532 16 99-16	Handle Bagger w/Lvrs Blk CRD	32	532 12 68-75	Rivet Rd Hd Drilled 3/8 Dia.
5	874 98 10-24	Screw Pan Head #10-24 x 1.50	33	532 16 55-71	Plug Mulcher
6	874 98 10-32	Screw Pan Hd	34	532 16 55-70	Handle Mulcher
7	873 40 10-00	Nut Wiz Lock Hex Serr/Hd 10-24	35	532 16 55-72	Pin Mulcher
8	532 18 10-95	Cover Bagger	36	819 13 20-12	Washer 13/32 x 1-1/4 x 12 Ga.
9	872 14 04-18	Bolt Carr. 1/4-20 x 2.25d x Gr. 5	37	532 17 54-01	Plug Support Bagger CRD
10	532 18 12-82	Tube Support Bagger CRD	38	872 01 05-20	Bolt 5/16-18 x 2-1/2
11	532 16 57-19	Bracket Support Upper Bag CRD	39	532 41 62-57	Seal
12	532 18 88-48	Bracket Pivot LH	41	532 16 96-83	Bracket Pnt Adj Pvt Bagger CRD
13	874 76 06-12	Bolt Fin Hex 3/8-16 unc x 3/4	43	532 17 40-83	Plug Tubing End
14	874 52 06-36	Bolt Fin Hex 3/8-16 x 2-1/4 Gr. 5	46	872 11 05-10	Bolt Carr. 5/16-18 x 1-1/4 Gr. 5
15	532 12 46-70	Retainer Spring	47	532 19 37-04	Tube Upper Bagger
16	873 90 06-00	Nut Lock Flange 3/8-16 unc	49	532 19 33-05	Bar Spreader
17	872 14 05-06	Bolt Rdhd Sht Sqnk 5/16-18 unc x 3/4	50	873 80 05-00	Nut Lock Hex w/Ins. 5/16-18 unc
19	873 90 05-00	Nut Lock Hex Flange 5/16-18	51	532 19 99-03	Latch Spring Bagger
20	532 18 88-47	Bracket Pivot RH	53	873 51 04-00	Nut Keps Hex 1/4-20 unc
21	532 40 61-80	Bag Asm CRD	54	872 14 04-06	Bolt Rdhd Sqnk 1/4-20 x 3/4 Gr. 5
22	532 16 57-81	Bracket Side Bagger CRD			
24	532 16 57-83	Tube Pivot Bagger CRD			
25	532 19 37-05	Tube Front Bagger			

NOTE: All component dimensions given in U.S. inches
1 inch = 25.4 mm

TRACTOR - - MODEL NO. CT131 (96061022202), PRODUCT NO. 960 61 02-22
MOWER DECK **44**

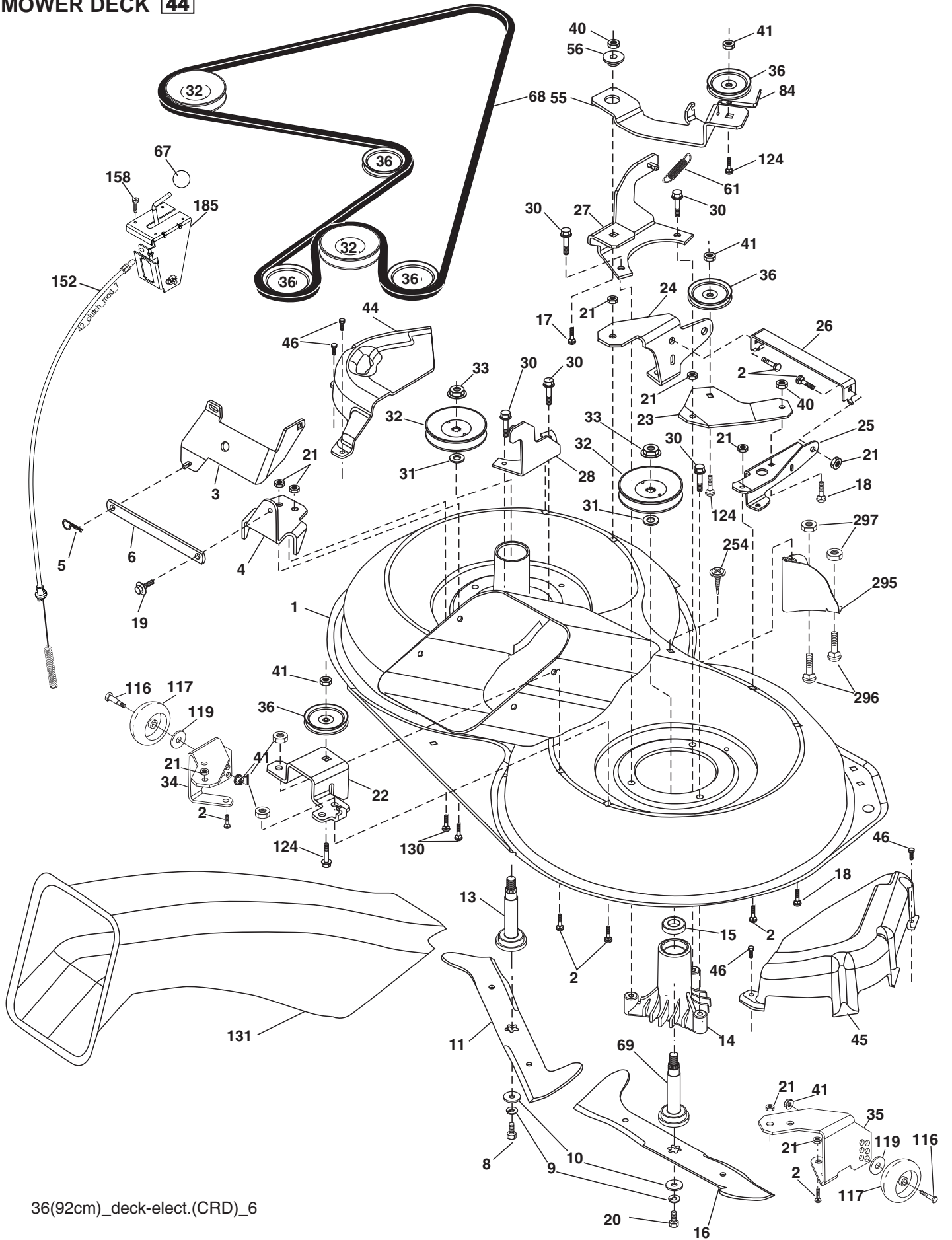

36(92cm)_deck-elect.(CRD)_6

**TRACTOR - - MODEL NO. CT131 (96061022202), PRODUCT NO. 960 61 02-22
MOWER DECK 44**

KEY NO.	PART NO.	DESCRIPTION	KEY NO.	PART NO.	DESCRIPTION
1	532 40 01-08	Housing Asm. Mower 92 CRD	45	532 17 55-39	Cover Mandrel RH 92 CRD
2	872 14 05-06	Bolt Rdhd Sqnk 5/16-18 unc x 3/4	46	532 13 77-29	Screw Thd Roll 1/4-20 x 5/8
3	532 16 55-69	Bracket Asm. S-Bar Chass 92 CRD	55	532 19 94-98	Arm Idler 92 CRD
4	532 16 55-58	Bracket Bar Sway Deck 92 CRD	56	532 16 57-23	Spacer Retainer Mower
5	532 12 46-70	Retainer Spring	61	532 19 94-86	Spring Tension Belt
6	532 16 55-57	Bar Sway 92 CRD	67	532 10 69-32	Knob Rd 3/8-16 Plstc Thds Blk
8	532 18 17-12	Bolt 3/8-24 x 1.25 Gr. 8 Patched	68	532 40 20-08	Hex-Belt 92 Mower
9	810 03 06-00	Washer Lock Hvy 3/8 Unplated	69	532 16 54-82	Shaft Asm w/Lwr Brg RH Thd CRD
10	532 14 02-96	Washer Hard	84	532 15 60-85	Keeper Belt Idler
11	532 18 63-85	Blade 3-1 LH 92 CRD	116	532 19 34-06	Bolt Shoulder
13	532 13 76-45	Shaft Asm. w/Lower Bearing	117	532 17 48-73	Wheel Gauge
14	532 12 87-74	Housing Mandrel Vented (Machd)	119	819 13 20-12	Washer 13/32 x 1-1/4 x 12 Ga.
15	532 11 04-85	Bearing Ball Mandrel	124	872 11 06-12	Bolt Carr Sh 3/8-16 x 1-1/2 Gr. 5
16	532 18 63-86	Blade 3-1 RH 92 CRD	130	872 11 05-06	Bolt Rdhdsqnk 5/16-18 unc x 3/4
17	872 14 06-10	Bolt Carriage 3/8-16 x 1-1/4	131	532 16 56-61	Chute Bagger CRD 92cm
18	872 11 06-06	Bolt Rdhd Sqnk 3/8-16 x 3/4	152	532 17 60-74	Cable Clutch CRD
19	532 13 28-27	Bolt Shoulder 5/16-18 Thd Form	158	817 72 04-08	Screw Hex Thd Cut 1/4-20 x 1/2
20	532 18 17-13	Bolt 3/8-24 x 1.25 Gr. 8 Ptch LH Thd	185	532 18 82-34	Head Asm. Cable Clutch
21	873 68 05-00	Nut Crown Lock 5/16-18	254	817 00 06-16	Screw 3/8-16 x 1
22	532 19 95-90	Bracket Idler Sprt 92 CRD	295	532 41 21-71	Baffle Front
23	532 16 54-46	Bracket Idler Sprt	296	872 14 04-06	Bolt RDHD SQNK 1/4-20 x 3/4 Gr. 5
24	532 16 52-42	Bracket Suspension LF 92 CRD	297	873 93 04-00	Nut Centerlock 1/4-20 unc
25	532 16 52-44	Bracket Suspension RF 92 CRD	---	532 18 18-57	Mandrel Assembly (Includes hous- ing, shaft assembly, and bear- ing only - pulley/nut/washer and blade bolt/washers not included)
26	532 40 01-10	Brace Susp Frt CRD	---	532 18 18-58	Mandrel Asm CRDLH Threads SVC
27	532 16 55-68	Bracket Asm. Susp RR 92 CRD	---	532 41 37-11	Replacement Mower, Complete (Std. Deck - Order separately gauge wheel components key nos. 116 - 119)
28	532 16 55-67	Bracket Asm. Susp LR 92 CRD			
30	532 17 39-84	Screw Thd Rolling			
31	532 18 76-90	Washer Spacer Mower Vented			
32	532 15 35-32	Mandrel Pulleys			
33	532 40 02-34	Nut Flg Top Lock			
34	532 40 01-07	Bracket Gauge Wheel LF 92 CRD			
35	532 40 01-06	Bracket Gauge Wheel RF 92 CRD			
36	532 14 67-63	Pulley Idler V-Groove Dim 4.25			
40	873 68 06-00	Nut Crownlock 3/8-16 unc			
41	873 90 06-00	Nut Lock Flg. 3/8-16 unc			
44	532 17 55-38	Cover Mandrel LH 92 CRD			

NOTE: All component dimensions given in U.S. inches
1 inch = 25.4 mm

TRACTOR - - MODEL NO. CT131 (96061022202), PRODUCT NO. 960 61 02-22
 MOWER LIFT **45**

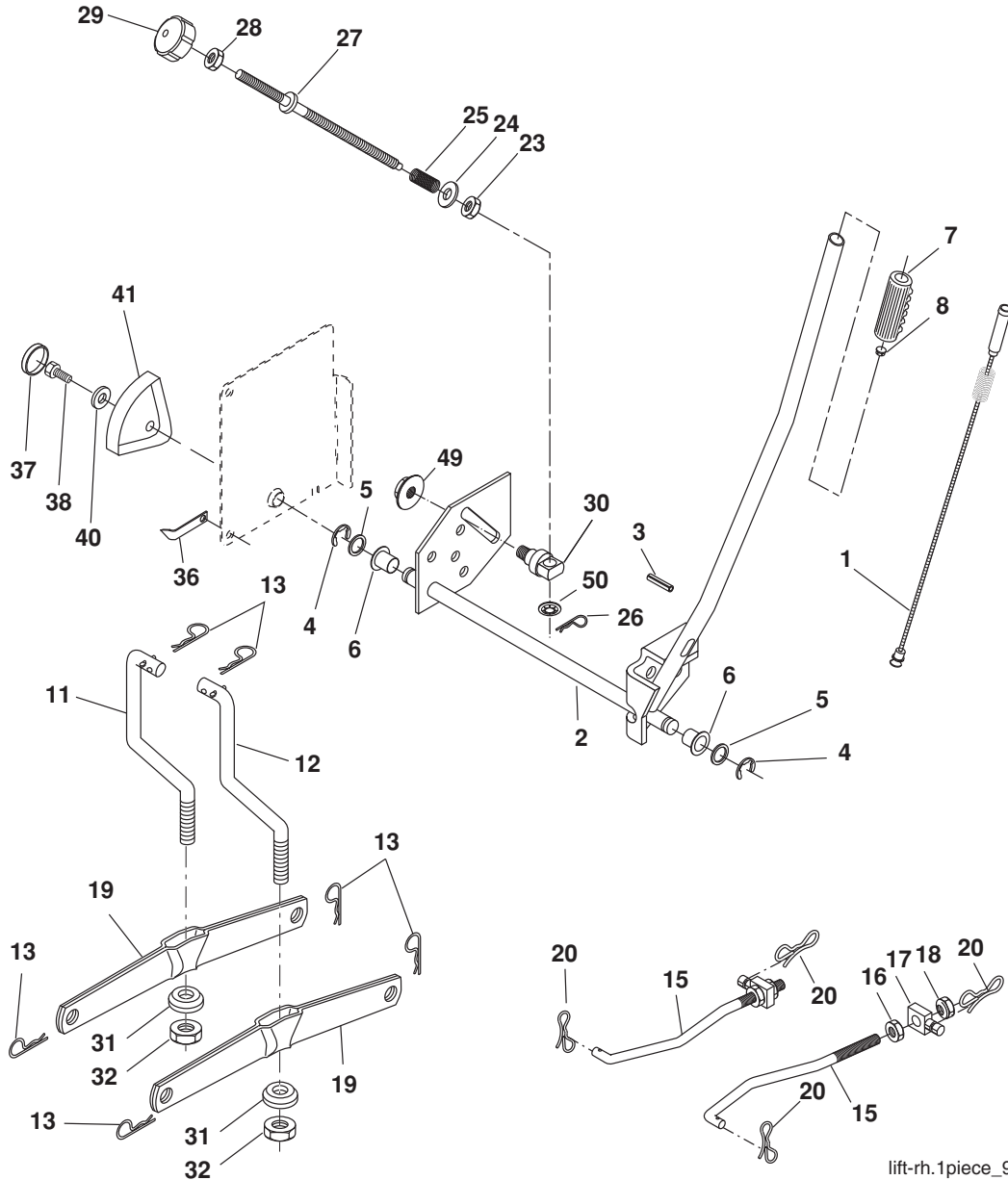

lift-rh.1piece_9

KEY NO.	PART NO.	DESCRIPTION
1	532 40 49-81	Plunger Asm. Lift
2	532 15 94-71	Shaft Asm. Lift
3	532 10 57-67	Pin Groove
4	812 00 00-02	E Ring #5133-62
5	819 21 16-21	Washer 21/32 x 1 x 21 Ga.
6	532 12 01-83	Bearing Nylon
7	532 10 94-13	Grip Handle Bicycle
8	532 12 45-26	Button Plunger Black
11	532 16 58-29	Link Asm Lift LH
12	532 16 58-31	Link Asm Lift RH
13	532 12 46-70	Retainer Spring
15	532 17 32-88	Link Front
16	873 35 08-00	Nut Jam Hex 1/2-13 unc
17	532 17 56-89	Trunnion Blk Zinc
18	873 80 08-00	Nut Lock w/Wsh 1/2-13 unc
19	532 13 98-68	Arm Suspension Mower
20	532 19 42-09	Pin Cotter 7/16 Bowtie Lock
23	532 11 08-07	Nut Special

KEY NO.	PART NO.	DESCRIPTION
24	819 13 10-16	Washer 13/32 x 5/8 x 16 Ga.
25	532 12 48-74	Spring 2-1/8"
26	532 16 94-84	Retainer Clip
27	532 12 69-71	Rod Adj Lift Zinc 7.49 Wrk Lg
28	873 35 06-00	Nut Hex Jam 3/8-16 unc
29	532 13 80-57	Knob Inf 3/8-16 Unc Blk w/sym
30	532 15 02-33	Trunnion Infin Height
31	532 16 98-65	Bearing, Pvt. Lift.
32	873 54 06-00	Nut Crownlock 3/8-24
36	532 15 50-97	Pointer Height Indicator
37	532 12 39-35	Plug Hole Blk 1.485/1.515 Dia
38	817 06 05-16	Screw 5/16-18 x 1
40	819 11 24-10	Washer 11/32 x 1-1/2 x 10 Ga.
41	532 12 39-34	Scale Ind Height Blk
49	532 14 52-12	Nut Hex Flange Lock
50	532 11 04-52	Nut Push Phos & Oil

NOTE: All component dimensions given in U.S. inches
 1 inch = 25.4 mm

