



# CTH220 Twin

**Spare parts**

**Ersatzteile**

**Pièces détachées**

**Reserve onderdelen**

**Repuestos**

**Reservdelar**

# ILLUSTRATED PARTS LIST

**MFG. ID NO. 96061019103**

**CUSTOMER CATALOG NO. CTH220TWIN**

**PRODUCT NO. 960 61 01-91**

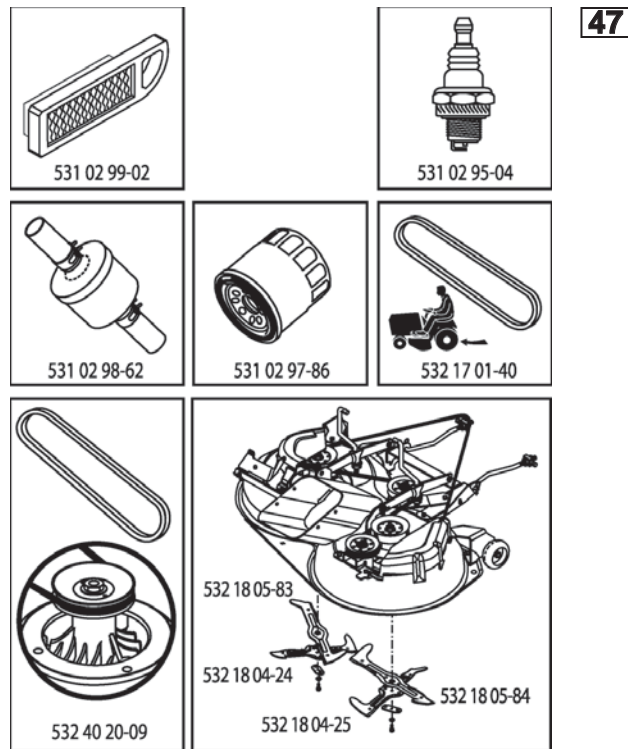

408798

**TRACTOR -- MODEL NO. CTH220TWIN (96061019103), PRODUCT NO. 960 61 01-91  
DECALS 27**

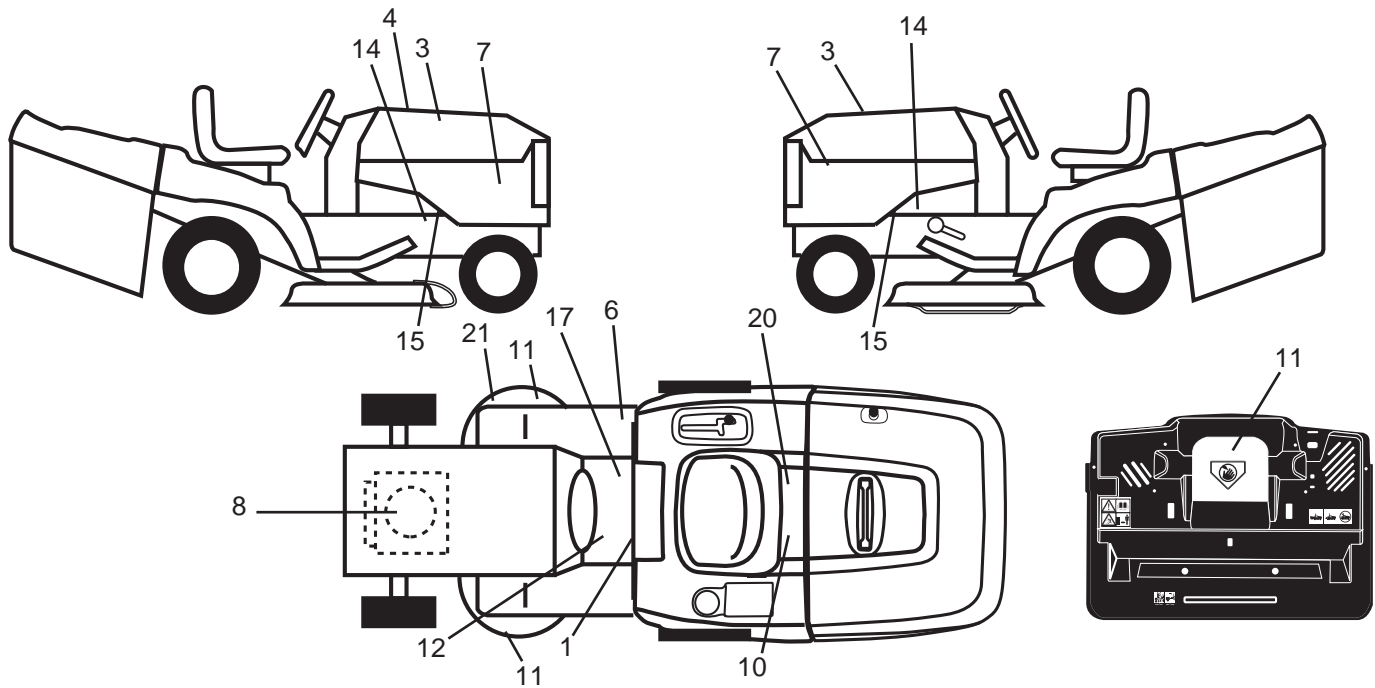

KEY NO.	PART NO.	DESCRIPTION
1	532 40 03-89	Decal, Warning Symbols CE
3	532 42 20-12	Decal, Hood
4	532 40 87-98	Decal, Replacement
6	532 18 04-32	Decal, 100 DBA
7	532 40 96-79	Decal, Hood Side Panel
8	532 19 68-41	Decal, Warning Eng. Sym.
10	532 14 50-05	Decal, Bat. Dan./Poi. P/L Sym. Wpnr.
11	532 18 21-66	Decal, Mower Cut Finger Symbol
12	532 15 97-37	Decal, Brake/Clutch Symbol Lt.
14	532 15 97-36	Decal, Chassis Hot Muffler

KEY NO.	PART NO.	DESCRIPTION
15	532 40 11-46	Decal, Warning Cut Finger
17	532 14 08-37	Decal, Saddle Brake Parking
20	532 16 69-60	Decal, Bypass Fender CRD
21	532 16 62-86	Decal, Hex Belt Sch. 92 CRD
--	532 18 04-35	Decal, Rear Plate CRD Symbols
--	532 13 83-11	Decal, Deck Lift
--	532 18 19-17	Pad Footrest RH
--	532 18 19-16	Pad Footrest LH
--	532 40 90-55	Manual Operator's (Euro)

**WHEELS & TIRES**

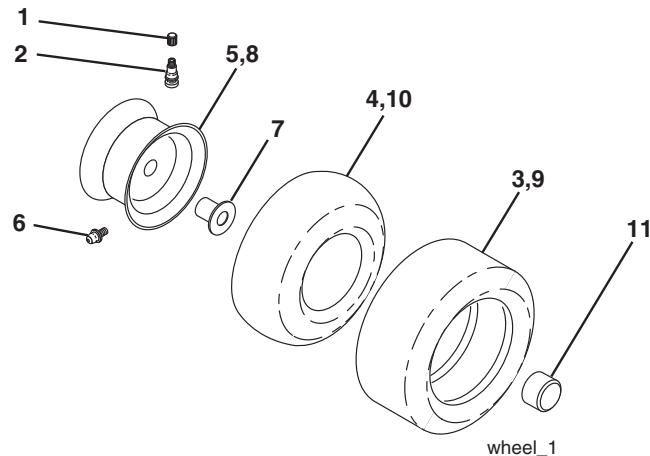

KEY NO.	PART NO.	DESCRIPTION
1	532 05 91-92	Cap Valve Tire
2	532 06 51-39	Stem Valve
3	532 10 62-22	Tire F Ts 15 x 6 0-6 Service
4	532 05 99-04	Tube Inner Front #35060
5	532 13 83-36	Rim Asm 6" Front Silver Service
6	532 12 49-57	Fitting Grease
7	532 12 49-59	Bearing Flange
8	532 13 83-37	Rim Asm 8" Rear Silver Service
9	532 12 20-82	Tire R Ts 20 x 10-8 Service
10	532 12 49-26	Tube Rear 9 5 x 8 Service
11	532 17 50-39	Cap Axle Blk. 1 50 x 1 00
--	532 14 43-34	Sealant, Tire (10 oz. tube)

**NOTE:** All component dimensions given in U.S. inches  
1 inch = 25.4 mm

# TRACTOR -- MODEL NO. CTH220TWIN (96061019103), PRODUCT NO. 960 61 01-91 SCHEMATIC **38**

SCH05

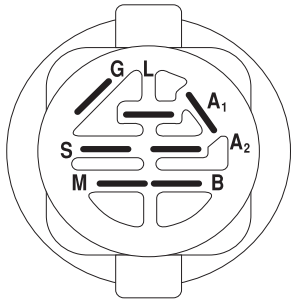
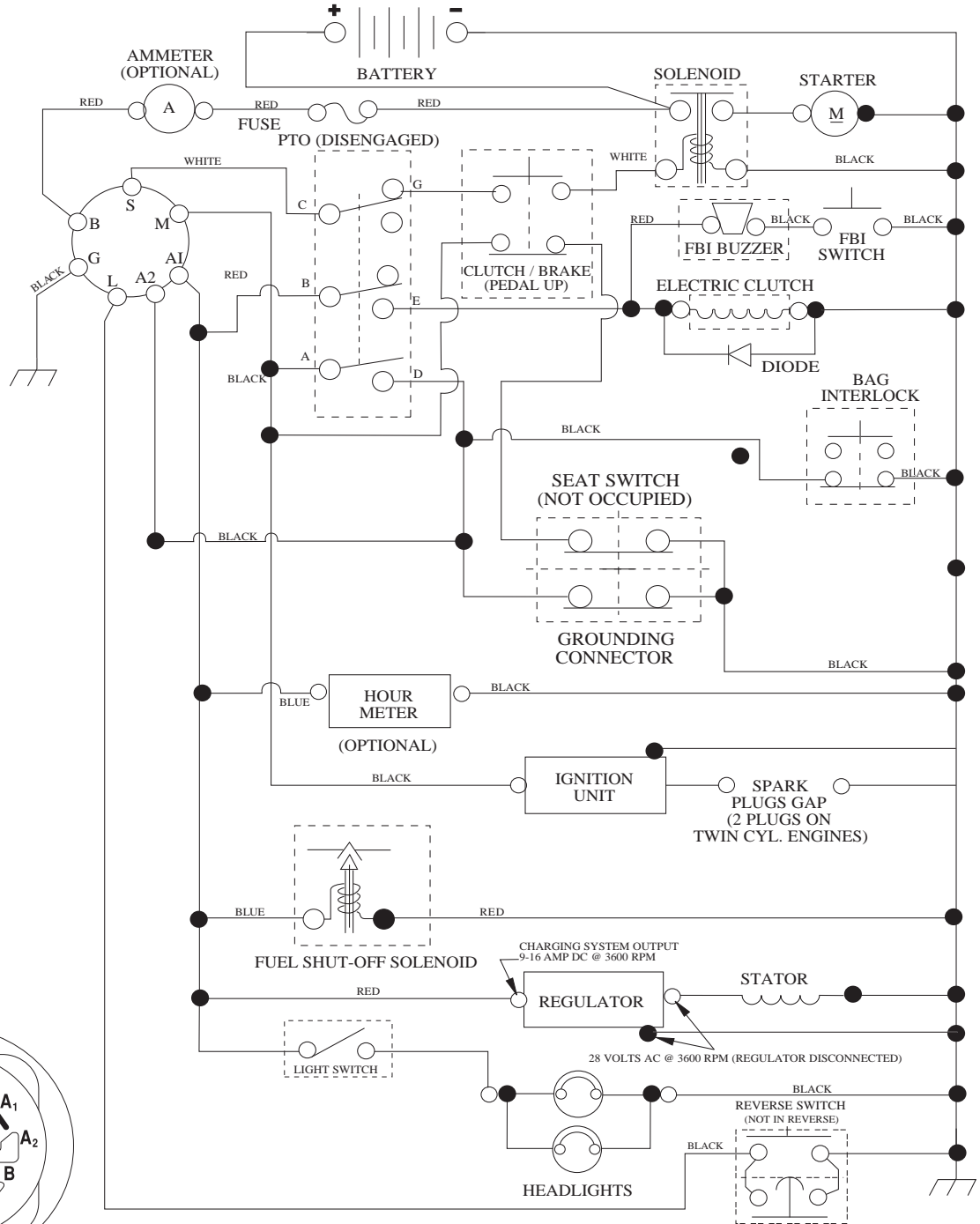

**IGNITION SWITCH**

POSITION	CIRCUIT	"MAKE"
OFF	M+G+A1	
RUN/OVERRIDE	B+A1	
RUN	B+A1	L+A2
START	B + S + A1	

WIRING INSULATED CLIPS  
NOTE: IF WIRING INSULATED CLIPS WERE REMOVED FOR SERVICING OF UNIT, THEY SHOULD BE RE-INSTALLED TO PROPERLY SECURE YOUR WIRING.

03048

**PTO SWITCH**

POSITION	CIRCUIT
OFF	C + G, B + H
ON	C + F, B + E, A + D

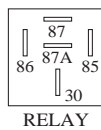

**RELAY**

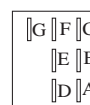

●  
NON-REMOVABLE CONNECTIONS

○  
REMOVABLE CONNECTIONS

TRACTOR -- MODEL NO. CTH220TWIN (96061019103), PRODUCT NO. 960 61 01-91  
ELECTRICAL **32**

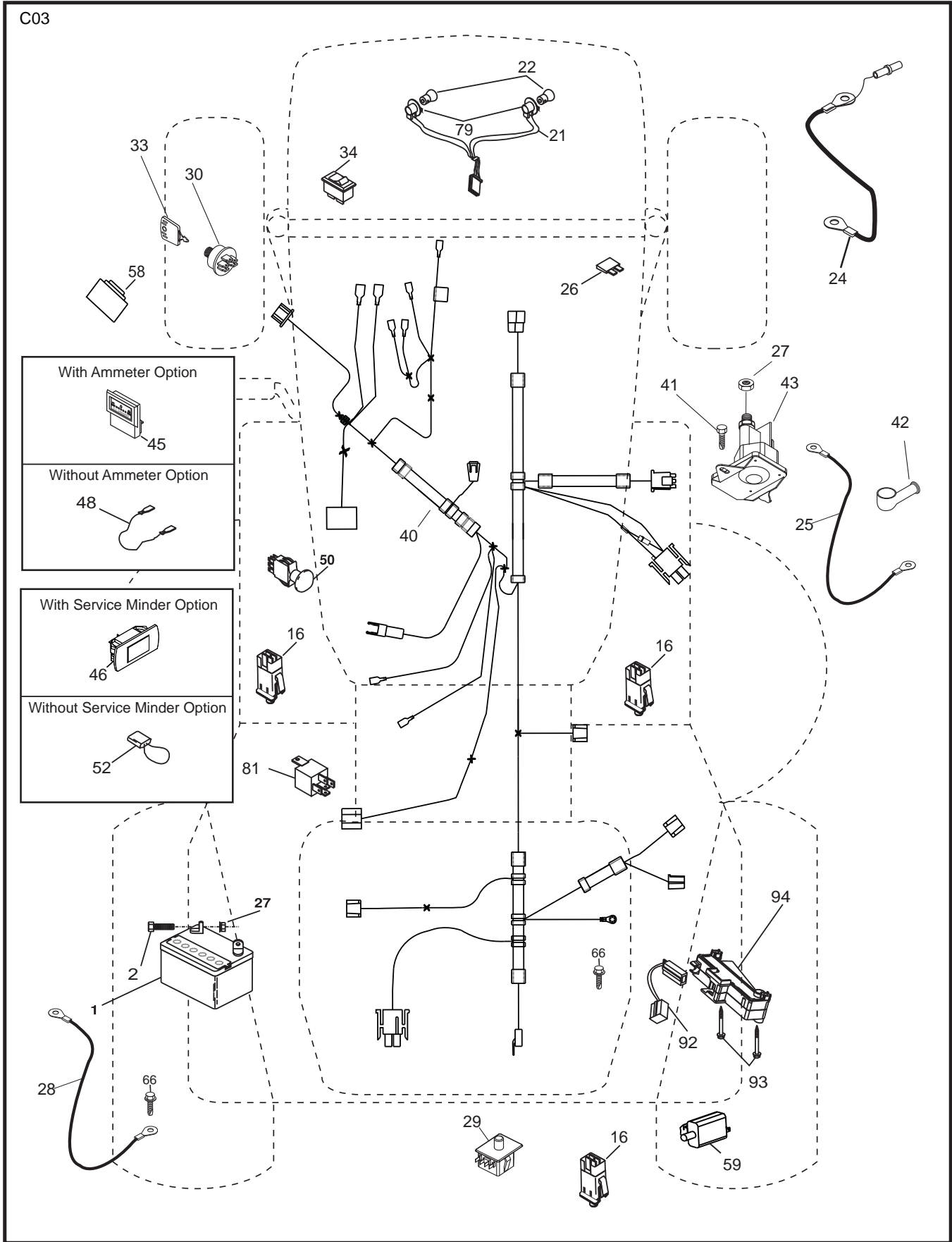

**TRACTOR -- MODEL NO. CTH220TWIN (96061019103), PRODUCT NO. 960 61 01-91  
ELECTRICAL 32**

<b>KEY NO.</b>	<b>PART NO.</b>	<b>DESCRIPTION</b>
1	532 16 34-65	Battery
2	874 76 04-12	Bolt Hex Hd 1/4-20 unc x 3/4
16	532 17 61-38	Switch Interlock
21	532 18 37-59	Harness Asm. Light w/4152J
22	532 00 41-52	Bulb Light #1156
24	532 10 84-23	Cable Starter 6 Ga. 11" Red
25	532 16 59-87	Cable Battery CRD 56" Red
26	532 17 51-58	Fuse
27	873 51 04-00	Nut Keps Hex 1/4-20 unc
28	532 12 77-25	Cable Ground 6 Ga. 18" Black
29	532 19 27-49	Switch Seat
30	532 19 33-50	Switch Ignition
33	532 41 19-35	Key/Chain
34	532 11 07-12	Switch Light
40	532 19 74-34	Harness Ignition
41	871 11 04-08	Bolt Flk. Fin. Hex 1/4-20 unc x 1/2
42	532 13 15-63	Cover Terminal Red
43	532 19 25-07	Solenoid
46	532 41 39-31	Service Minder Hourmeter
48	532 14 08-44	Adapter Ammeter Rectangular
50	532 17 46-51	Switch PTO
58	532 16 94-19	Buzzer CRD
59	532 18 03-79	Switch FBI CRD
66	817 49 06-08	Screw Thdrol. 3/8-16 x 1/2 Ty-Tt
79	532 17 52-42	Socket Asm. Bulb Twistlock
81	532 10 97-48	Relay Asm.
92	532 19 66-15	Harness Pigtail
93	532 19 25-40	Screw Plastite 10-44 x 2.0
94	532 19 18-34	Module Reverse

**NOTE:** All component dimensions given in U.S. inches.  
1 inch = 25.4 mm.

TRACTOR -- MODEL NO. CTH220TWIN (96061019103), PRODUCT NO. 960 61 01-91  
CHASSIS AND ENCLOSURES **39**

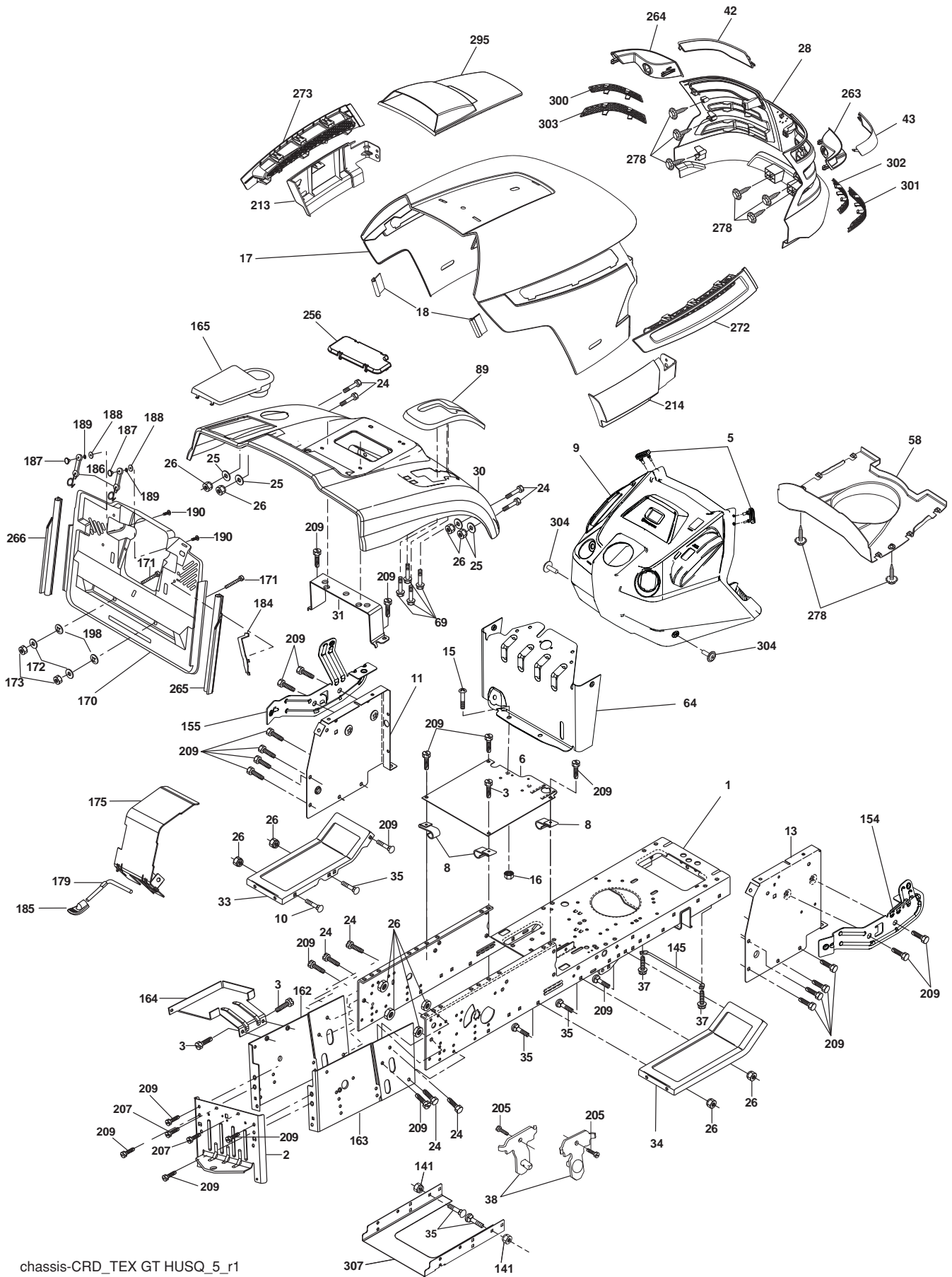

chassis-CRD\_TEX GT HUSQ\_5\_r1

**TRACTOR -- MODEL NO. CTH220TWIN (96061019103), PRODUCT NO. 960 61 01-91  
CHASSIS AND ENCLOSURES 39**

KEY NO.	PART NO.	DESCRIPTION	KEY NO.	PART NO.	DESCRIPTION
1	532 17 46-20	Chassis	165	532 18 11-00	Cover Battery
2	532 18 03-84	Drawbar	170	532 19 94-88	Backplate CRD
3	817 06 06-12	Screw 3/8-16 x 3/4	171	872 14 06-20	Bolt Rdhd. Sqnk. 3/8-16 x 2-1/2 Gr. 5
5	532 40 75-90	Bumper Hood	172	819 13 20-16	Washer 13/32 x 1-1/4 x 16 Ga.
6	532 18 44-19	Saddle	173	873 51 06-00	Nut, Keps Hex 3/8-16 unc
8	532 12 64-71	Clip Insulator 13/32 Mtg. Hole	175	532 18 82-03	Guard Trap
9	532 40 89-11	Dash Upper	179	532 18 82-02	Rod Pivot FBI CRD
10	872 14 06-08	Bolt, Carriage 3/8-16 x 3/4	184	532 17 46-62	Bracket Actuator Bagger CRD
11	532 16 72-03	Panel, Dash, LH	185	532 18 11-01	Knob Rod Brake Parking
13	532 17 82-98	Panel, Asm. Dash RH	186	532 16 07-93	Latch Asm. Mulch/Bagger
15	874 18 05-12	Screw, Machine, THD 5/16-18 unc x 3/4	187	532 12 50-04	Nut Weld
16	873 51 05-00	Nut Keps 5/16-18 unc	188	819 06 12-16	Washer #10
17	532 41 10-46	Hood	189	810 07 10-00	Washer Lock #10
18	532 40 47-42	Bumper Hood	190	871 08 10-10	Screw Pan Hd. Phillip 10-24 x 5/8
24	874 78 06-16	Bolt	198	532 16 89-37	Nut, Push
25	819 13 13-12	Washer 13/32 x 13/16 x 12 Ga.	205	817 49 06-08	Screw Thdrol. 3/8-16 x 1/2
26	873 80 06-00	Nut	207	817 67 05-08	Screw Thdrol. 5/16-18 x 1/2
28	532 40 86-07	Grille /Lens Asm.	209	817 00 06-12	Screw Hex Wsh. Thdrol. 3/8-16
30	532 19 73-76	Fender	213	532 40 17-11	Skirt Side LH
31	532 16 51-56	Bracket, Fender Support	214	532 40 17-09	Skirt Side RH
33	532 18 10-57	Footrest, LH	256	532 18 13-61	Cover Fender Rack
34	532 18 10-58	Footrest, RH	263	532 19 71-98	Bezel RH
35	872 11 06-06	Bolt	264	532 19 71-99	Bezel LH
37	817 49 05-08	Screw Thdrol. 5/16-18 x 1/2 TYT	265	532 18 57-04	Seal RH Side Bagger
38	532 18 17-48	Bracket Asm. Pivot Mower Rear	266	532 18 57-03	Seal LH Side Bagger
42	532 19 89-07	Lens LH	272	532 40 30-48	Vent Hood RH
43	532 19 89-06	Lens RH	273	532 40 30-76	Vent Hood LH
58	532 19 85-12	Duct Air	278	532 41 63-58	Screw #10 x 0.750 BOS Thread
64	532 19 93-95	Dash Lower	295	532 41 66-15	Vent Top Hood
69	532 14 24-32	Screw Hx. Wsh. Hi-Lo 1/4-1/2	300	532 19 91-31	Insert Hex Top LH
89	532 19 73-77	Console CRD Auto Grey	301	532 19 91-30	Insert Hex Top RH
141	873 90 06-00	Nut	302	532 19 91-32	Insert Hex Bottom RH
145	532 40 91-67	Rod Pivot Chassis/Hood	303	532 19 91-33	Insert Hex Bottom LH
154	532 40 86-90	Bracket Mounting Dash RH	304	817 06 04-10	Hex Tapping Screw
155	532 40 86-91	Bracket Mounting Dash LH	307	532 42 51-25	Shield Chassis Front
162	532 18 03-82	Bracket Exten Chassis LH CRD			
163	532 18 03-83	Bracket Exten Chassis RH CRD			
164	532 16 56-05	Support Battery CRD			

**NOTE:** All component dimensions given in U.S. inches.  
1 inch = 25.4 mm.





**TRACTOR -- MODEL NO. CTH220TWIN (96061019103), PRODUCT NO. 960 61 01-91  
DRIVE 40**

KEY NO.	PART NO.	DESCRIPTION	KEY NO.	PART NO.	DESCRIPTION
1	-----	Transaxle Hydro Gear 321-0510	95	532 17 00-15	Control Asm. Bypass Hydro
8	532 19 27-06	Rod, Shift Fender Adjust Lt.	96	532 12 47-88	Spring, Retainer 1"
9	532 19 81-43	Clutch Elect	112	819 09 12-10	Washer 9/32 x 3/4 x 10 Ga.
10	876 02 04-16	Pin, Cotter 1/8 x 1	120	873 90 06-00	Nut Lock Flg. 3/8-16 unc
14	810 04 04-00	Washer, Lock Hvy. Helical	150	532 16 58-50	Bushing, Bellcrank Grnd. Dr.
15	874 49 05-44	Bolt Hex FGHD 5/16-18 x Gr. 5	151	819 13 32-10	Washer 13/32 x 2 x 10 Ga.
16	873 80 05-00	Nut Lock Hex w/Ins. 5/16-18 unc	156	532 16 60-02	Washer Srrted. 5/16 ID x 1.125
17	532 12 61-97	Washer 1-1/2 OD x 15/32 ID x .250	158	532 16 55-89	Bracket Shift Mount
19	873 80 06-00	Nut Lock Hex w/Ins. 3/8-16 unc	159	532 18 39-00	Hub Shift
20	532 17 39-37	Bolt Hex 7/16-20 x 4 x Gr. 5-1.5	161	872 14 04-06	Bolt Rdhd. Sqnk. 1/4-20 x 3/4 Gr. 5
21	532 12 12-74	Knob Duckhead 1/4-13 unc Blk.	162	873 68 04-00	Nut Crownlock 1/4-20 unc
22	532 17 56-07	Brake Rod	163	874 78 04-16	Bolt Hex Fin. 1/4-20 unc x 1 Gr. 5
24	873 35 06-00	Nut Hex Jam 3/8-16 unc	165	532 16 56-23	Bracket Pivot Lever
25	532 19 20-36	Spring, Rod, Brake	166	817 49 05-10	Screw 5/16-18 x 5/8
27	876 02 04-12	Pin, Cotter 1/8 x 3/4	167	532 16 55-88	Bracket Support Shift CRD
28	532 17 57-65	Rod, Parking Brake	168	532 16 54-92	Bolt Shoulder 5/16-18 x .561
29	532 12 42-36	Cap, Parking Brake	169	532 16 55-80	Plate Fastening Lt.
30	532 16 95-92	Bracket, Mfg. Transaxle	171	817 49 06-08	Screw Thdrol. 3/8-16 x 1/2 Ty-Tt
32	874 76 05-12	Bolt Hex HD 5/16-18 unc x 3/4	172	532 17 02-71	Shift Asm. Shifter Frt. CRD
34	532 17 55-78	Shaft, Asm. Pedal Foot CRD	177	532 16 59-32	Keeper Flat Idler 3.06" CRD
35	532 12 01-83	Bearing, Nylon	181	532 18 02-11	Bracket Idler Ground Drive CRD
36	819 21 16-16	Washer 21/32 x 1 x 16 Ga.	182	532 18 26-82	Keeper Belt 2.5" OD V-Idler CRD
37	532 12 49-63	Pin, Roll 3/16 x 1"	183	532 19 95-32	Pulley V-Idler 2.50" OD CRD
38	532 16 59-36	Pulley Flat Composite 3.06"	185	532 17 00-08	Link Shift
39	874 76 06-44	Bolt Fin. Hex 3/8-16 unc x 2-3/4	186	532 16 56-14	Hub Tapered Round CRD
40	532 12 49-65	Spacer, Split 395 x 59 Bzp.	187	817 58 05-20	Screw Thdrol. 5/16-18 x 1.25
42	819 13 13-12	Washer 13/32 x 13/16 x 12 Ga.	197	532 16 96-13	Nyliner Snap-In 5/8
43	819 11 10-12	Washer 11/32 x 5/8 x 12 Ga.	199	532 16 96-12	Bolt Shoulder 5/16-18 unc
47	532 12 77-83	Pulley, Idler, V Groove Plastic	200	872 14 05-08	Bolt Rdhd. Sqnk. 5/16-18 x 1
48	532 15 44-07	Bellcrank Clutch Grnd. Drv.	207	532 16 98-45	Washer Nylon Rear
49	532 12 32-05	Retainer, Belt Style Spring	214	532 17 56-09	Shaft Asm. Brake
50	872 11 06-12	Bolt Carr. Sh. 3/8-16 x 1-1/2 Gr. 5	215	532 17 56-52	Rod Brake Hydro
51	873 68 06-00	Nut, Crownlock 3/8-16 unc	243	532 19 07-36	Bracket Anti-Rotation
52	873 68 05-00	Nut Crownlock 5/16-18	252	819 13 16-16	Washer 13/32 x 1 x 16 Ga.
53	532 19 96-52	Link, Clutch 7.66	254	817 00 06-16	Screw 3/8-16 x 1
55	532 10 57-09	Spring, Return, Clutch	255	532 17 56-08	Brace Shaft Brake Mtg.
56	817 06 06-20	Screw 3/8-16 x 1-1/4	258	532 17 80-62	Clip Retainer
57	532 17 01-40	V-Belt Kev 112" 0650 CRD	259	532 18 02-12	Bracket Pulley
62	532 12 48-72	Cover, Pedal	261	532 13 14-94	Pulley Idler Flat
63	532 18 03-97	Pulley Engine CVX	262	872 11 06-22	Bolt Carr. 3/8-16 x 2-3/4 Gr. 5
65	810 04 07-00	Washer	263	817 00 06-12	Screw 3/8-16 x 3/4
66	532 15 47-78	Keeper, Belt Engine F-Proof	264	532 19 76-07	Bracket Idler Chassis
71	532 16 91-83	Strap, Torque, LH	266	532 18 20-61	Shield Idler Mower
73	532 16 91-82	Strap, Torque, RH	279	872 11 06-16	Bolt Rh. Hd. Sq. 3/8-16 unc x 2
74	532 13 70-57	Spacer, Split	292	532 40 02-71	Spacer Noram CRD
75	532 12 17-49	Washer 25/32 x 1-1/4 x 16 Ga.	295	532 17 91-14	Pulley Idler Composite
76	812 00 00-01	Ring, E	296	532 42 09-20	Shield Chassis Rear
77	532 12 35-83	Key, Square			
78	532 12 17-48	Washer 25/32 x 1-5/8 x 16 Ga.			
81	532 17 00-06	Asm, Shaft, Cross Rear			
82	532 16 57-11	Spring, Torsion			
83	819 17 12-16	Washer 17/32 x 3/4 x 16 Ga.			
84	532 17 00-07	Link, Transaxle			

**NOTE:** All component dimensions given in U.S. inches  
1 inch = 25.4 mm

**TRACTOR -- MODEL NO. CTH220TWIN (96061019103), PRODUCT NO. 960 61 01-91  
ENGINE 24**

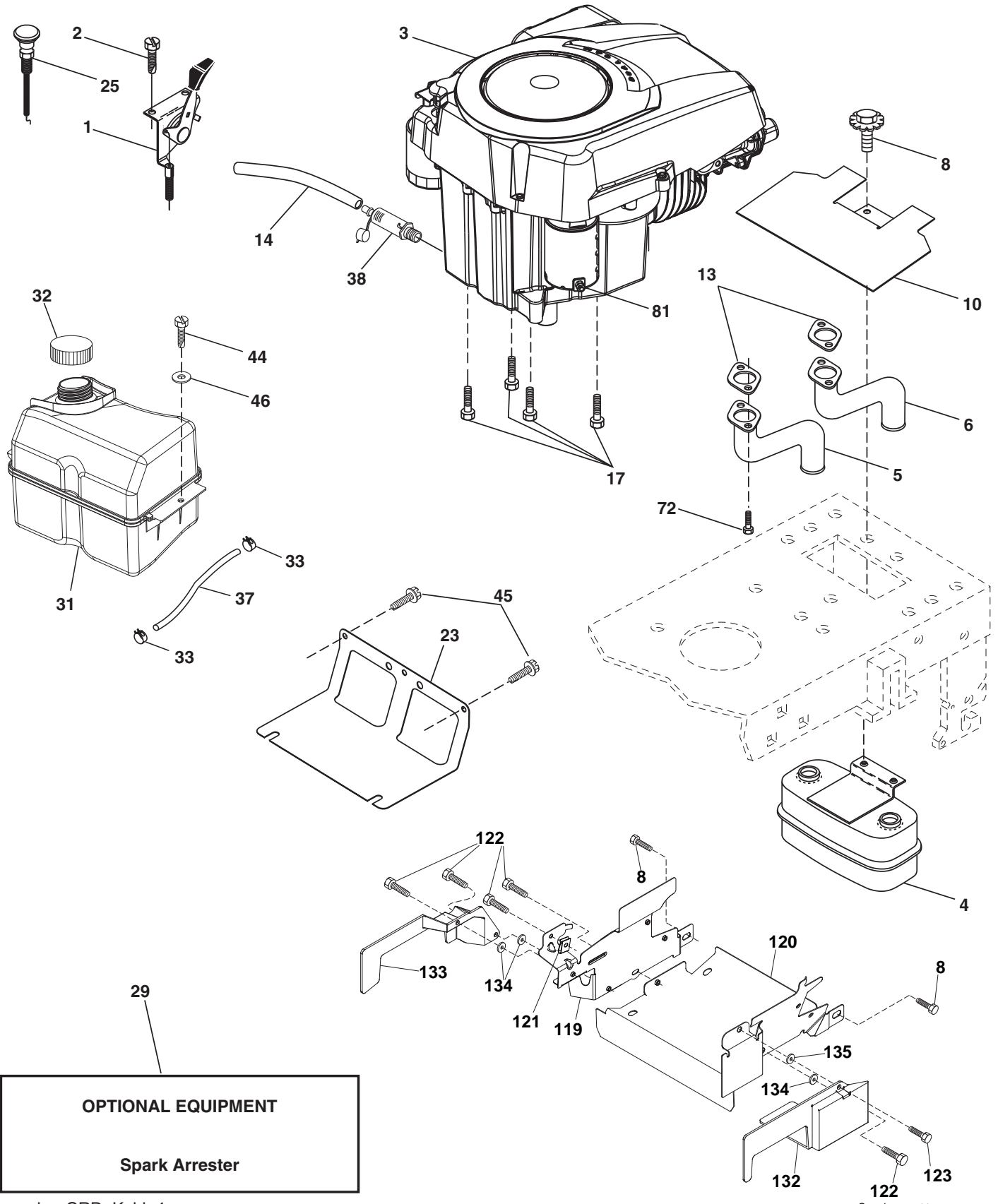

engine-CRD\_Kohl\_4

**TRACTOR -- MODEL NO. CTH220TWIN (96061019103), PRODUCT NO. 960 61 01-91  
ENGINE 24**

<b>KEY NO.</b>	<b>PART NO.</b>	<b>DESCRIPTION</b>
1	532 18 29-37	Control Throt.
2	532 41 63-58	Screw #10 x 0.750 BOS Thread
3	-----	Engine Kohler SV715-0010
4	532 14 97-23	Muffler Exhaust
5	532 14 66-99	Tube, Exhaust LH
6	532 14 67-00	Tube, Exhaust RH
8	532 17 18-77	Bolt 5/16-18 x 3/4
10	532 14 66-29	Shield Browning Intek
13	532 18 60-54	Gasket
14	532 14 84-56	Tube Drain Oil Easy
17	817 12 06-16	Screw 3/8-16
23	532 16 98-37	Shield Browning/Debris Guard
25	532 18 95-41	Choke Control
29	532 13 71-80	Arrester Spark
31	532 40 74-89	Tank Fuel
32	532 19 77-25	Cap Asm. Fuel Top
33	532 12 34-87	Clamp Hose Blk.
37	532 13 70-40	Line Fuel 20"
38	532 18 16-54	Plug Drain Oil Easy
44	817 67 04-12	Screw Hex Wsh. Thdrol. 1/4-20 x 3/4
45	817 00 06-12	Screw Hex Wsh. Thdr. 3/8-16 x 3/4
46	819 09 14-16	Washer 9/32 x 7/8 x 16 Ga.
72	532 19 23-34	Screw Socket HD 5/16-18 x .75
81	873 51 04-00	Nut Keps 1/4-20 unc
119	532 19 97-68	Guard Asm. Engine LH
120	532 19 97-67	Guard Asm. Engine RH
121	532 19 66-88	Clip Threaded
122	532 13 77-29	Screw 1/4-20 x 5/8
123	817 67 05-08	Screw 5/16-18 x 1/2
132	532 42 07-57	Shield Side RH
133	532 42 07-56	Shield Side LH
134	532 42 30-62	Palnut 1/4"
135	532 42 30-63	Palnut 5/16"

**NOTE:** All component dimensions given in U.S. inches  
1 inch = 25.4 mm

TRACTOR -- MODEL NO. CTH220TWIN (96061019103), PRODUCT NO. 960 61 01-91  
 STEERING ASSEMBLY **41**

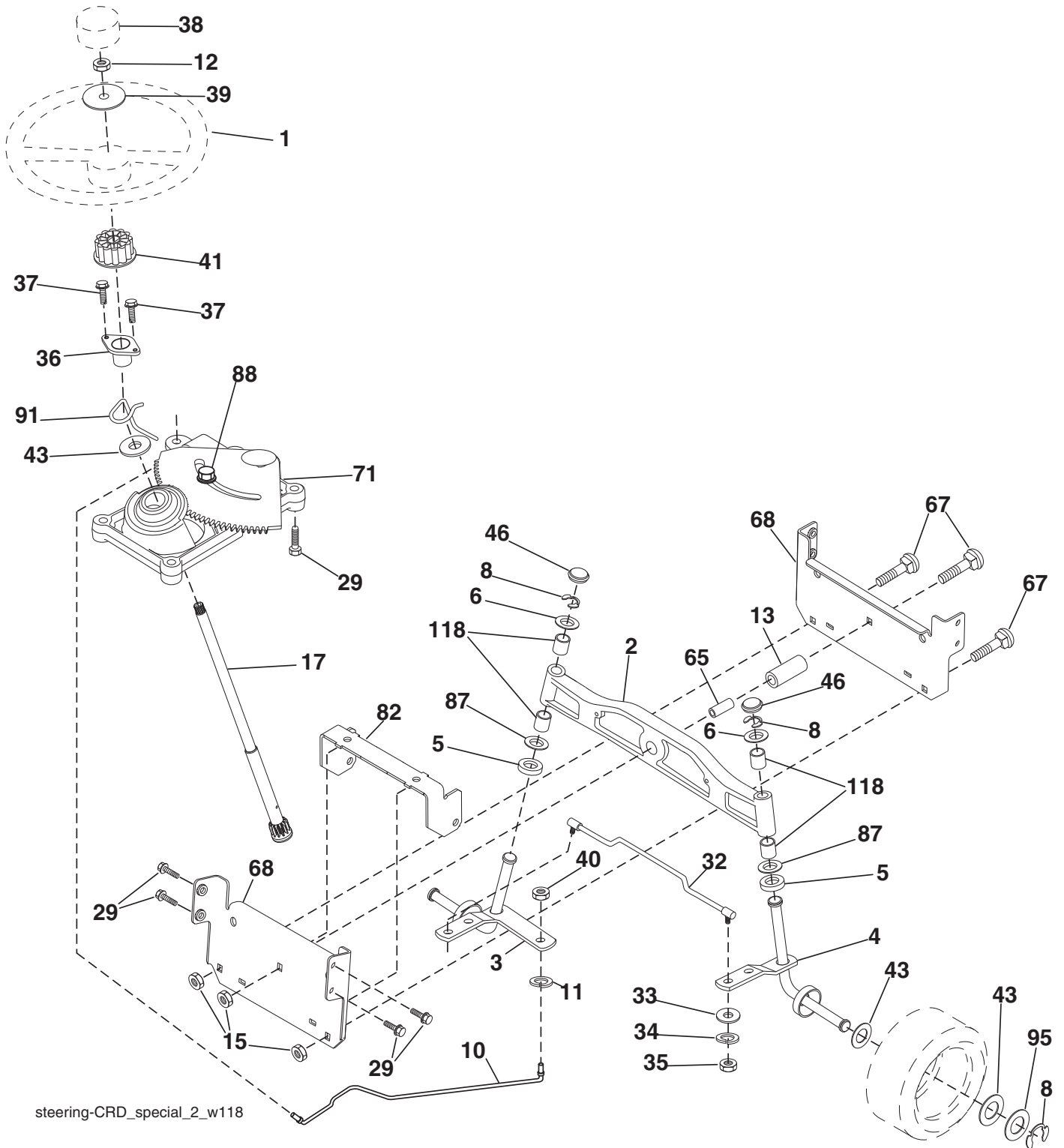

steering-CRD\_special\_2\_w118

**TRACTOR -- MODEL NO. CTH220TWIN (96061019103), PRODUCT NO. 960 61 01-91  
STEERING ASSEMBLY 41**

<b>KEY NO.</b>	<b>PART NO.</b>	<b>DESCRIPTION</b>
1	532 41 64-80	Steering Wheel Husq SR
2	532 19 35-42	Axle Asm Cast Iron Lt.
3	532 16 98-40	Spindle Assembly, LH
4	532 16 98-39	Spindle Assembly, RH
5	532 12 49-31	Bearing, Race, Thrust, Hardened
6	532 12 17-48	Washer 25/32 x 1-5/8 x 16 Ga.
8	812 00 00-29	Ring, Clip
10	532 17 51-21	Link, Drag
11	810 04 06-00	Washer, Lock
12	873 94 08-00	Nut Hex Jam Toplock 1/2-20 unf
13	532 13 65-18	Spacer Brg. Axle Front
15	532 14 52-12	Nut Hex Flange Lock
17	532 17 78-83	Shaft, Steering
29	817 00 06-12	Screw 3/8-16 x 3/4
32	532 17 18-88	Rod, Tie
33	819 11 12-16	Washer 11/32 x 3/4 x 16 Ga.
34	810 04 05-00	Washer Lock Hvy. Hlcl. Spr. 5/16
35	873 54 05-00	Crownlock Nut 5/16-24 unf 3847
36	532 15 51-05	Bushing, Steering
37	532 15 29-27	Screw TT #10-32 x 5 x 3/8 Flange
38	532 41 59-87	Cap Wheel Steering Husq SR
39	819 18 38-12	Washer 9/16 ID x 2-3/8 OD x 12 Ga.
40	873 54 06-00	Nut Lock 3/8-24
41	532 18 67-37	Adaptor, Steering Wheel
43	532 12 17-49	Washer 25/32 x 1-1/4 x 16 Ga.
46	532 12 12-32	Cap, Spindle
65	532 41 47-36	Spacer Brace Axle
67	872 11 06-18	Bolt Rdhd. Sqnk. 3/8-16 x 2-1/4
68	532 16 98-27	Brace Axle
71	532 17 51-46	Steering Asm.
82	532 19 99-78	Bracket Susp. Chassis Front
87	532 17 39-66	Washer Flat .781 x 1-1/2 x .14
88	532 17 51-18	Bolt Shoulder 7/16-20 unc
91	532 17 55-53	Clip Steering
95	532 18 89-67	Washer
118	532 40 60-13	Bushing

**NOTE:** All component dimensions given in U.S. inches.  
1 inch = 25.4 mm.

TRACTOR -- MODEL NO. CTH220TWIN (96061019103), PRODUCT NO. 960 61 01-91  
 MOWER DECK 44

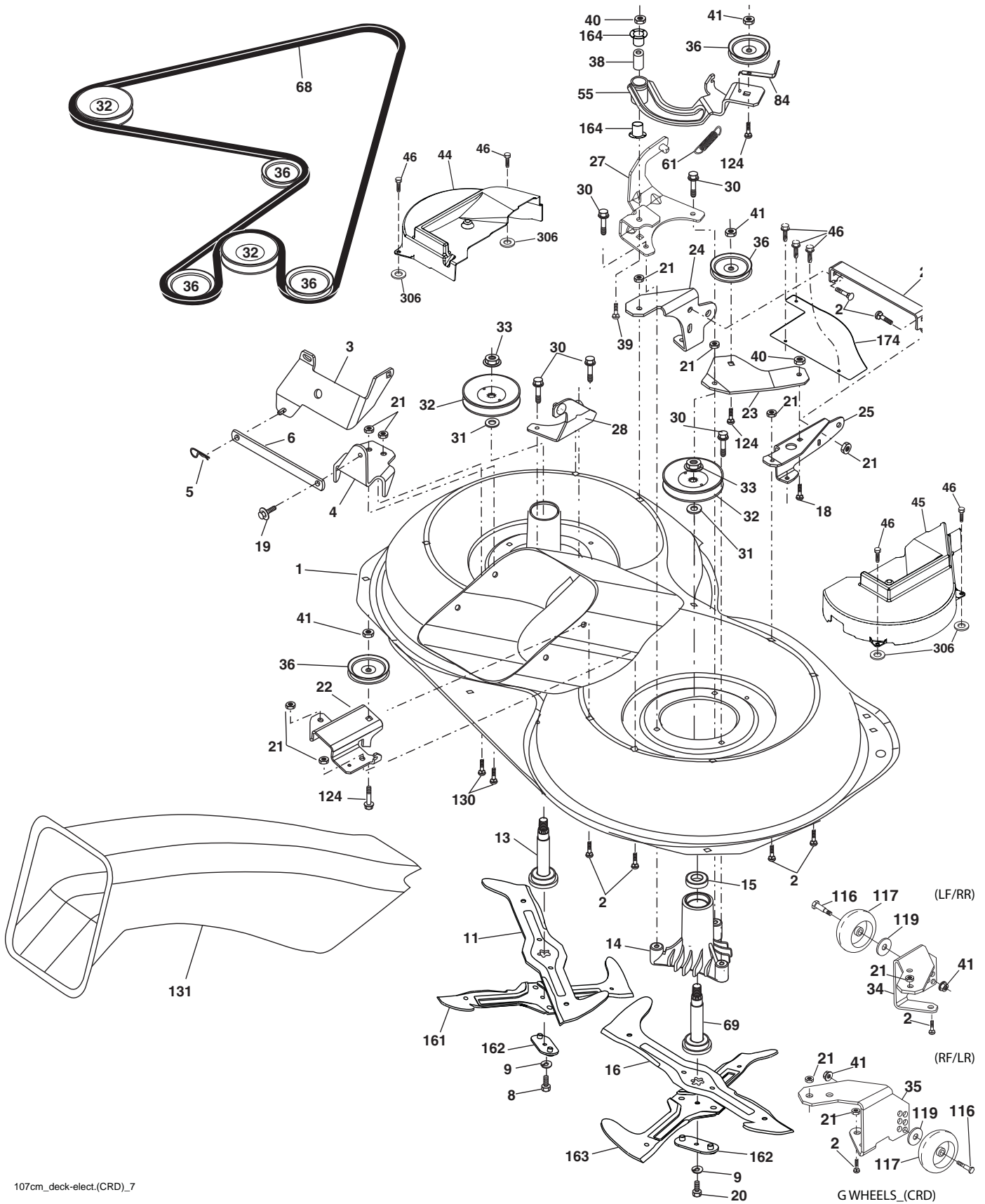

107cm\_deck-elect.(CRD)\_7

GWHEELS\_(CRD)

**TRACTOR -- MODEL NO. CTH220TWIN (96061019103), PRODUCT NO. 960 61 01-91  
MOWER DECK 44**

KEY NO.	PART NO.	DESCRIPTION	KEY NO.	PART NO.	DESCRIPTION
1	532 16 91-60	Housing Asm. Mower	38	532 16 98-51	Spacer Hub Arm Idler
2	872 14 05-06	Bolt Rdhd. Sqnk. 5/16-18 unc x 3/4	39	872 11 06-22	Bolt Rd. Hd. 3/8-16 unc x 2-3/4 Gr. 5
3	532 16 55-69	Bracket Asm. S-Bar Chass	40	873 68 06-00	Nut Crownlock 3/8-16 unc
4	532 16 91-67	Bracket Bar Sway Deck	41	873 90 06-00	Nut Flangelock 3/8-16 unc
5	532 12 46-70	Retainer Spring	44	532 42 07-54	Cover Mandrel LH
6	532 16 55-57	Bar Sway	45	532 42 07-55	Cover Mandrel RH
8	532 18 17-12	Bolt 3/8-24 x 1.25 Gr. 8 Patched	46	532 13 77-29	Screw Thd. Roll 1/4-20 x 5/8
9	810 03 06-00	Washer Lock Hvy. 3/8 Unplated	55	532 16 98-49	Arm Idler
11	532 18 05-83	Blade 3-1 LH	61	532 19 94-87	Spring Tension Belt
13	532 13 76-45	Shaft Asm. w/Lower Bearing	68	532 40 20-09	Hex-Belt Mower Drive
14	532 12 87-74	Housing Mandrel Vented (Machd.)	69	532 16 54-82	Shaft Asm. w/Lwr. Brg. RH Thd. CRD
15	532 11 04-85	Bearing Ball Mandrel	84	532 15 60-85	Keeper Belt Idler
16	532 18 05-84	Blade 3-1 RH	116	532 19 34-06	Bolt Shoulder
18	872 11 06-06	Bolt Rdhd. Sqnk. 3/8-16 x 3/4 Gr. 5	117	532 17 48-73	Wheel Gauge
19	532 13 28-27	Bolt Shoulder 5/16-18 Thd. Form	119	819 13 20-12	Washer 3/8 x 7/8 x 14 Ga.
20	532 18 17-13	Bolt 3/8-24 x 1.25 Gr. 8 Ptch. LH Thd.	124	872 11 06-12	Bolt Carr. Sh. 3/8-16 x 1-1/2 Gr. 5
21	873 68 05-00	Nut Crown Lock 5/16-18	130	872 11 05-06	Bolt Rdhd. Sqnk. 5/16-18 unc x 3/4
22	532 16 91-65	Bracket Idler Sprt RR	131	532 16 56-61	Chute Bagger CRD 92cm
23	532 16 91-66	Bracket Idler Sprt RF	161	532 18 04-24	Blade Cross LH 107
24	532 41 34-36	Bracket Suspension LF	162	532 18 08-78	Adapter Weldment Blade 107
25	532 40 01-05	Bracket Suspension RF	163	532 18 04-25	Blade Cross RH 107
26	532 40 01-10	Brace Susp. Frt. CRD	164	532 12 49-37	Bearing
27	532 16 91-72	Bracket Asm. Susp. RR	174	532 40 02-40	Guard Susp. Front
28	532 16 91-68	Bracket Asm. Susp. LR	306	532 42 30-62	Palnut 1/4"
30	532 17 39-84	Screw Thd. Rolling Dod. PT Hex	---	532 18 18-57	Mandrel Asm. Service
31	532 18 76-90	Washer Spacer Mower Vented	---	532 18 18-58	Mandrel Asm. CRD LH Threads VC
32	532 19 81-45	Mandrel Pulleys	---	532 42 27-89	Replacement Mower Complete
33	532 40 02-34	Nut Flg. Top Lock			
34	532 40 01-03	Bracket Gauge Wheel LF			
35	532 40 01-04	Bracket Gauge Wheel RF			
36	532 14 67-63	Pulley Idler V-Groove Dim. 4.25			

**NOTE:** All component dimensions given in U.S. inches  
1 inch = 25.4 mm



TRACTOR -- MODEL NO. CTH220TWIN (96061019103), PRODUCT NO. 960 61 01-91  
 MOWER LIFT **45**

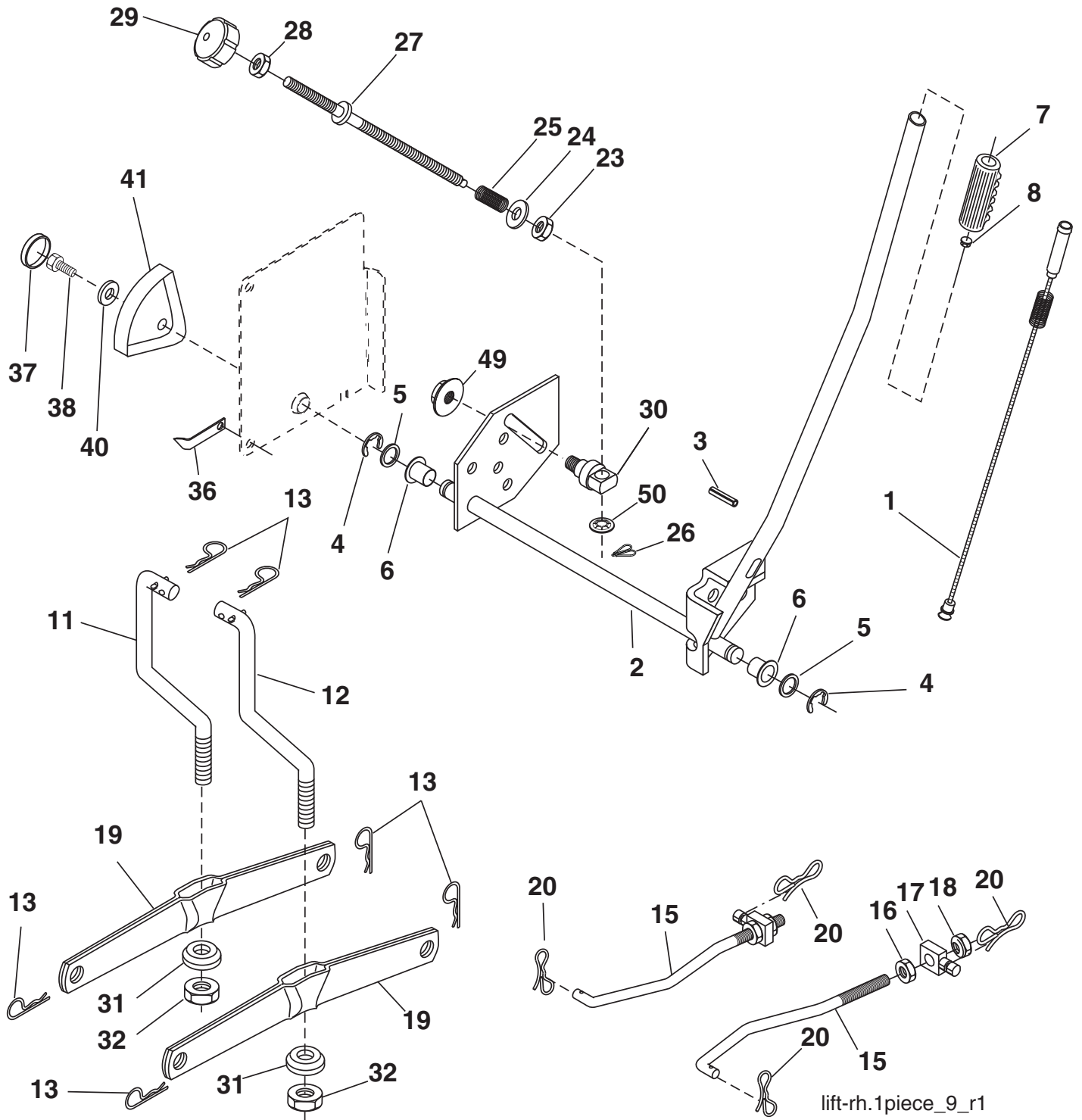

**TRACTOR -- MODEL NO. CTH220TWIN (96061019103), PRODUCT NO. 960 61 01-91  
MOWER LIFT 45**

<b>KEY NO.</b>	<b>PART NO.</b>	<b>DESCRIPTION</b>
1	532 40 50-07	Plunger Asm. Lift LVR
2	532 19 80-70	Shaft Asm. Lift
3	532 18 88-22	Pin Groove
4	812 00 00-02	E Ring #5133-62
5	819 21 16-21	Washer 21/32 x 1 x 21 Ga.
6	532 12 01-83	Bearing Nylon
7	532 12 56-31	Grip Handle Fluted
8	532 12 23-65	Button Plunger Red
11	532 16 58-29	Link Asm. Lift LH
12	532 16 58-31	Link Asm. Lift RH
13	532 12 46-70	Retainer Spring
15	532 17 32-88	Link Front
16	873 35 08-00	Nut Jam Hex 1/2-13 unc
17	532 17 56-89	Trunnion Blk. Zinc
18	873 80 08-00	Nut Lock w/Wsh. 1/2-13 unc
19	532 13 98-68	Arm Suspension Mower
20	532 19 42-09	Pin Cotter 7/16 Bowtie Lock
23	532 11 08-07	Nut Special
24	819 13 10-16	Washer 13/32 x 5/8 x 16 Ga.
25	532 16 40-24	Spring
26	532 16 94-84	Retainer Clip
27	532 16 45-43	Rod Adj. Lift
28	873 35 06-00	Nut Hex Jam 3/8-16 unc
29	532 13 80-57	Knob Inf. 3/8-16 unc Blk. w/Sym.
30	532 15 02-33	Trunnion Infin. Height
31	532 16 98-65	Bearing, Pvt. Lift.
32	873 54 06-00	Nut Crownlock 3/8-24
36	532 15 50-97	Pointer Height Indicator
37	532 12 39-35	Plug Hole Blk. 1.485/1.515 Dia.
38	817 06 05-16	Screw 5/16-18 x 1
40	819 11 24-10	Washer 11/32 x 1-1/2 x 10 Ga.
41	532 12 39-34	Scale Ind Height Blk.
49	532 14 52-12	Nut Hex Flange Lock
50	532 11 04-52	Nut Push Phos & Oil

**NOTE:** All component dimensions given in U.S. inches  
1 inch = 25.4 mm

**TRACTOR -- MODEL NO. CTH220TWIN (96061019103), PRODUCT NO. 960 61 01-91**  
**SEAT ASSEMBLY 42**

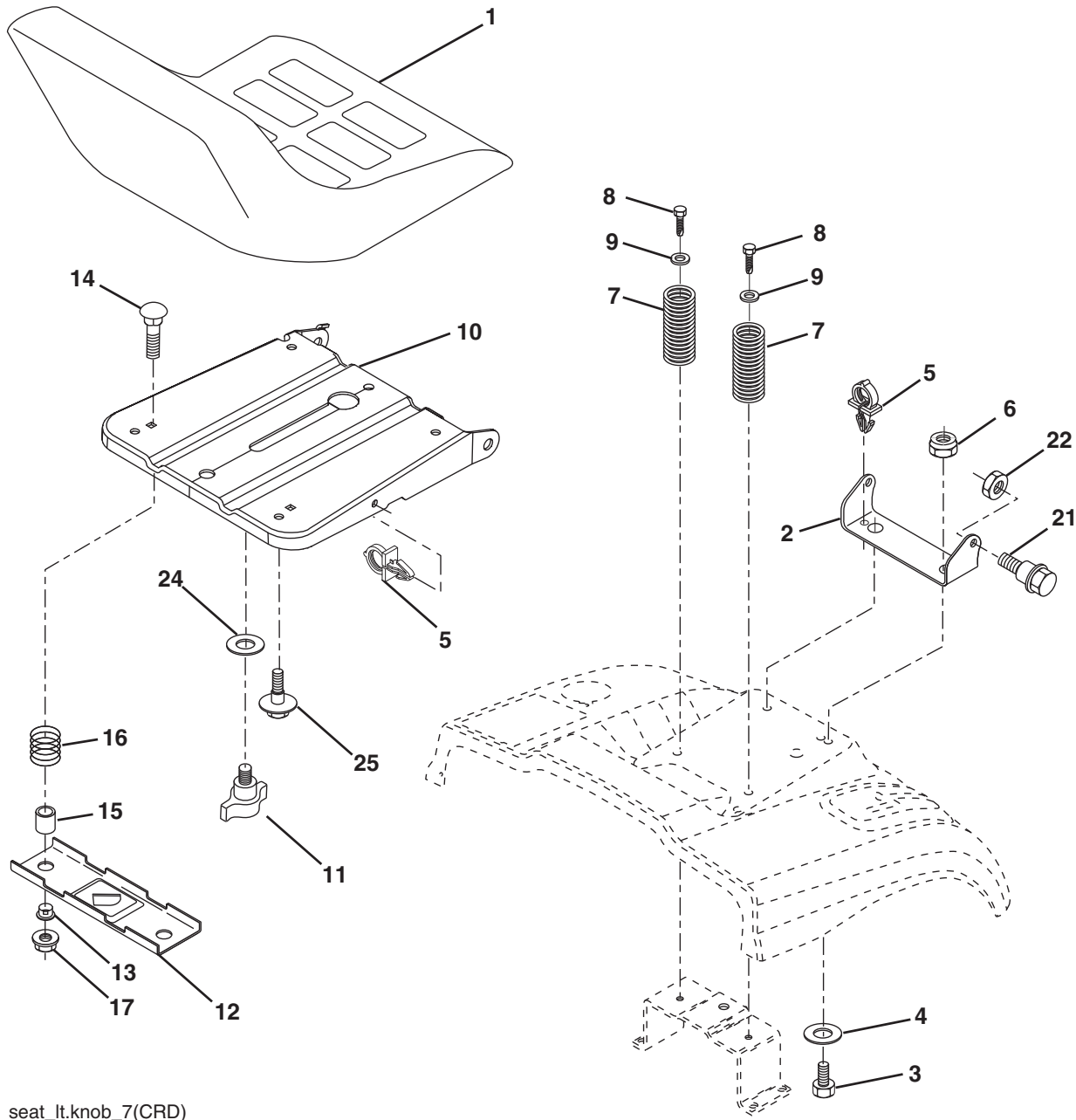

seat\_lt.knob\_7(CRD)

KEY NO.	PART NO.	DESCRIPTION
1	532 18 87-15	Seat
2	532 14 05-51	Bracket Pnt. Pivot Seat (Blk.)
3	871 11 06-16	Bolt Fin Hex 3/8-16 x 1
4	819 13 16-10	Washer Flat 13/32 x 1 x 10 Ga.
5	532 14 50-06	Clip Push In Hinged
6	873 80 06-00	Nut Lock Hex w/Ins 3/8-16
7	532 12 41-81	Spring Seat Cprsn. 2 250 Blk. Zi.
8	817 00 06-16	Screw 3/8-16 x 1.5
9	819 13 16-14	Washer 13/32 x 1 x 14 Ga.
10	532 19 55-30	Pan Pnt. Seat
11	532 16 63-69	Knob Seat Adj. Wingnut
12	532 17 46-48	Bracket Pnt. Mounting Switch

KEY NO.	PART NO.	DESCRIPTION
13	532 12 12-48	Bushing Snap Blk. Nyl. 50 Id.
14	872 05 04-12	Bolt Rdhd. Sht. Nk. 1/4-20 x 1-1/2
15	532 12 12-49	Spacer Split
16	532 12 37-40	Spring Cprsn.
17	532 12 39-76	Nut Lock 1/4 Lge. Fig. Gr. 5 Zinc
21	532 17 18-52	Bolt Shoulder 5/16-18 unc-2A
22	873 80 05-00	Nut Hex Lock w/Ins. 5/16-18
24	819 17 19-12	Washer 17/32 x 1-3/16 x 12 Ga.
25	532 12 70-18	Bolt Shoulder 5/16-18 x 62

**NOTE:** All component dimensions given in U.S. inches.  
 1 inch = 25.4 mm

**TRACTOR -- MODEL NO. CTH220TWIN (96061019103), PRODUCT NO. 960 61 01-91  
BAGGER 46**

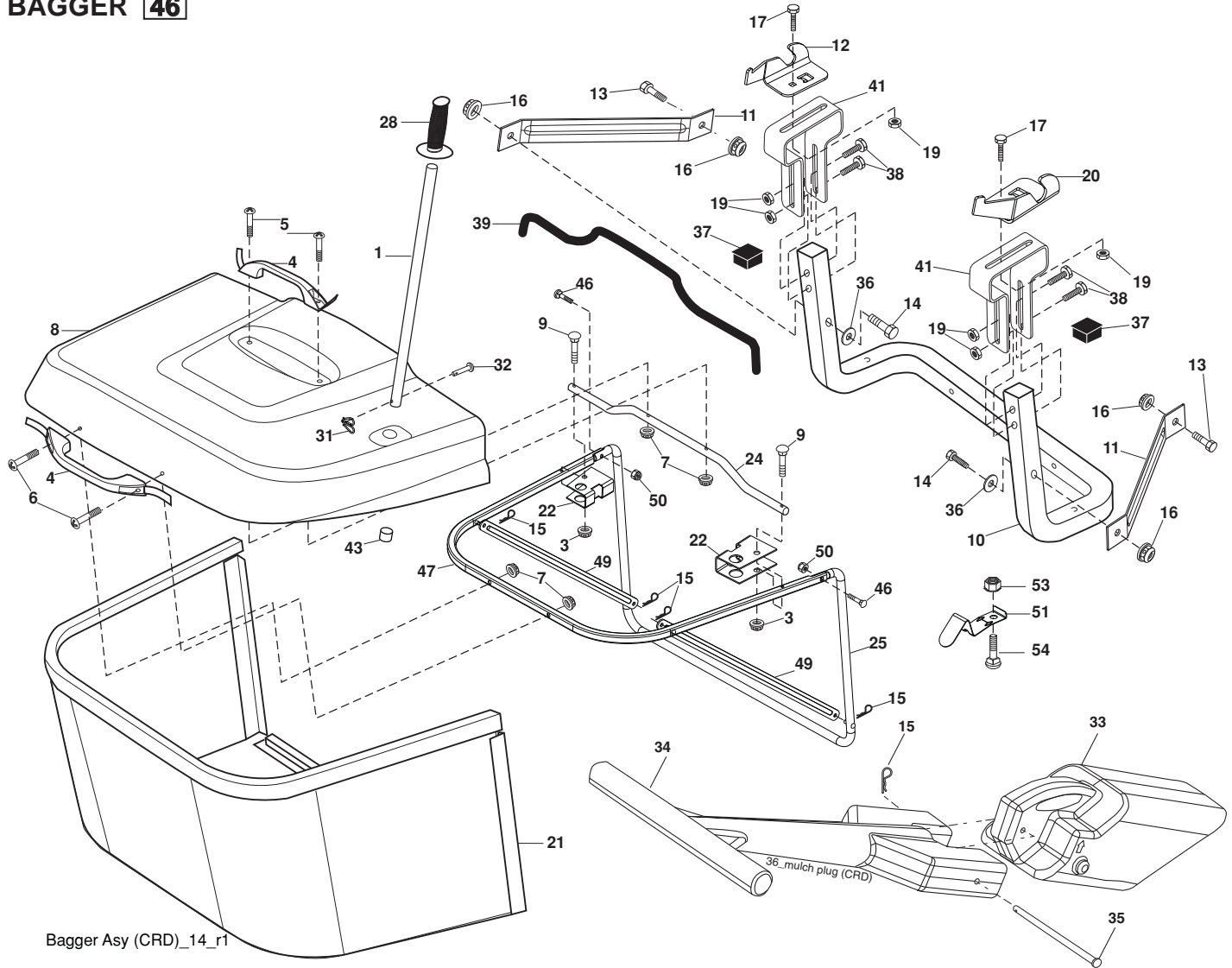

Bagger Asy (CRD)\_14\_r1

KEY NO.	PART NO.	DESCRIPTION	KEY NO.	PART NO.	DESCRIPTION
1	532 16 52-49	Tube Handle Bagger CRD	28	532 16 57-87	Grip Handle
3	532 12 39-76	Nut Lock 1/4 Lge. Flg. Gr. 5 Zinc	31	532 16 94-84	Retainer Clip
4	532 16 99-16	Handle Bagger w/Lvrs. Blk. CRD	32	532 12 68-75	Rivet Rd. Hd. Drilled 3/8 Dia
5	874 98 10-24	Screw Pan Head #10-24 x 1.50 Blk.	33	532 16 93-80	Plug Mulcher
6	874 98 10-32	Screw Pan Hd.	34	532 16 55-70	Handle Mulcher
7	873 40 10-00	Nut Wiz Lock Hex Serr./Hd. 10-24	35	532 16 55-72	Pin Mulcher
8	532 18 10-95	Cover Bagger	36	819 13 20-12	Washer 13/32 x 1-1/4 x 12 Ga.
9	872 14 04-18	Bolt Carriage 1/4-20 x 2.25d x Gr. 5	37	532 17 54-01	Plug Support Bagger CRD
10	532 18 12-82	Tube Support Bagger CRD	38	872 01 05-20	Bolt 5/16-18 x 2-1/2
11	532 16 57-19	Bracket Support Upper Bag CRD	39	532 41 62-57	Seal
12	532 18 88-48	Bracket Pivot LH	41	532 16 96-83	Bracket Pnt. Adj. Pvt. Bagger CRD
13	874 76 06-12	Bolt 3/8-16 unc x 3/4	43	532 17 40-83	Plug Tubing End
14	874 52 06-36	Bolt Fin Hex 3/8-16 x 2-1/4 Gr. 5	46	872 11 05-10	Bolt 5/16-18 x 1-1/4
15	532 12 46-70	Retainer Spring	47	532 19 37-04	Tube Upper Bagger
16	873 90 06-00	Nut Lock 3/8-16 unc	49	532 19 33-05	Bar Spreader
17	872 14 05-06	Bolt Rdhd. Sht. Sqnk. 5/16-18 unc x 3/4	50	873 80 05-00	Nut 5/16-18
19	873 90 05-00	Nut Lock Hex Flange 5/16-18	51	532 19 99-03	Latch Spring Bagger
20	532 18 88-47	Bracket Pivot RH	53	873 51 04-00	Nut 1/4-20 unc
21	532 40 61-80	Bag Asm. CRD	54	872 14 04-06	Bolt 1/4-20 x 3/4 Gr. 5
22	532 16 57-81	Bracket Side Bagger CRD			
24	532 16 57-83	Tube Pivot Bagger CRD			
25	532 19 37-05	Tube Front Bagger			

**NOTE:** All component dimensions given in U.S. inches  
1 inch = 25.4 mm

