

CTH200 Twin

Spare parts

Ersatzteile

Pièces détachées

Reserve onderdelen

Repuestos

Reservdelar

ILLUSTRATED PARTS LIST

MFG. ID NO. 96061022701

CUSTOMER CATALOG NO. CTH200TWIN

PRODUCT NO. 960 61 02-27

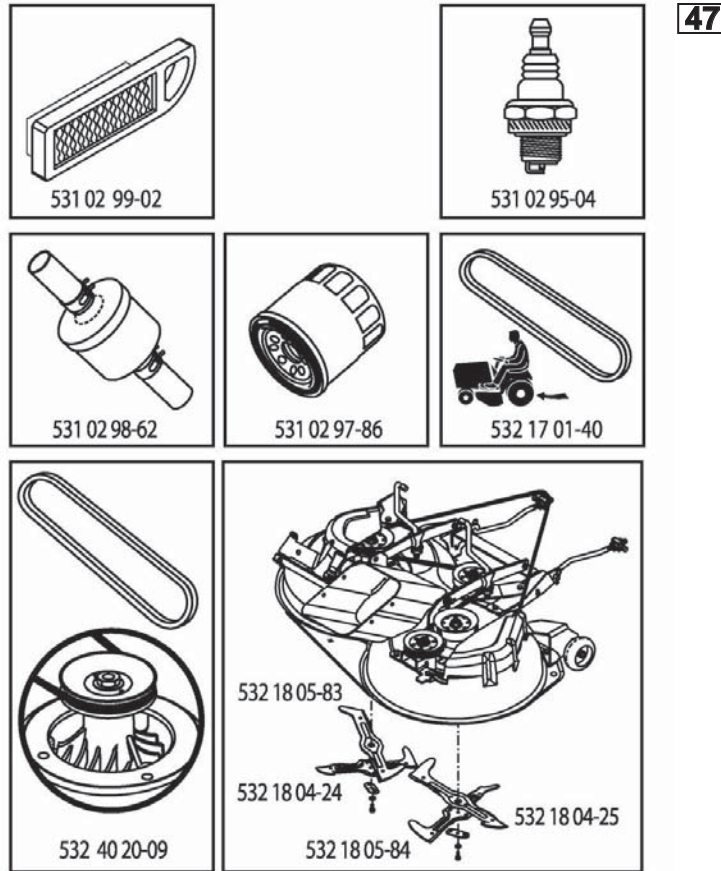

415748

**TRACTOR - - MODEL NO. CTH200 TWIN (96061022701), PRODUCT NO. 960 61 02-27
DECALS 27**

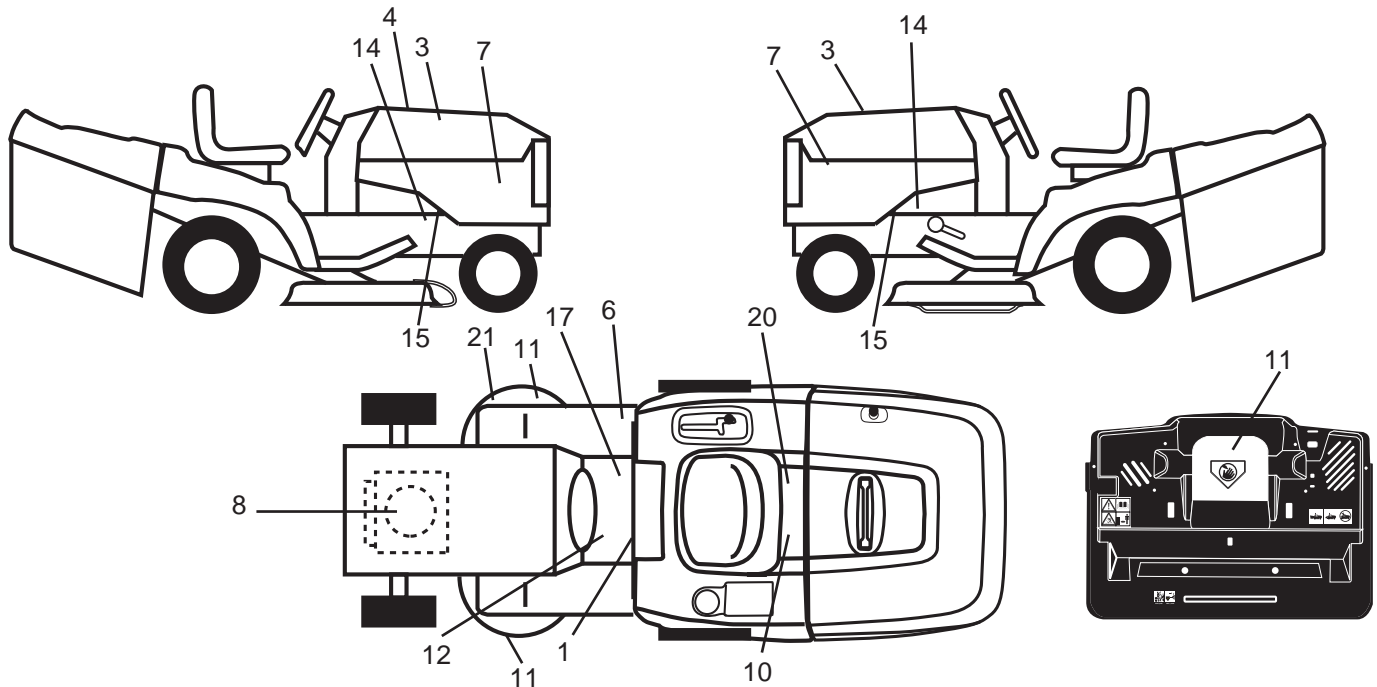

| KEY NO. | PART NO. | DESCRIPTION |
|---------|--------------|--------------------------------|
| 1 | 532 40 03-89 | Decal, Warning Symbols CE |
| 3 | 532 42 20-12 | Decal, Hood |
| 4 | 532 41 57-48 | Decal, Replacement |
| 6 | 532 18 04-32 | Decal, 100 DBA |
| 7 | 532 41 60-13 | Decal, Hood Side Panel |
| 8 | 532 19 68-41 | Decal, Warning Eng. Sym |
| 10 | 532 14 50-05 | Decal, Bat Dan/Poi P/L Sym Wpn |
| 11 | 532 18 21-66 | Decal, Mower Cut Finger Symbol |
| 12 | 532 15 97-37 | Decal, Brake/Clutch Symbol Lt |
| 14 | 532 15 97-36 | Decal, Chassis Hot Muffler |

| KEY NO. | PART NO. | DESCRIPTION |
|---------|--------------|-------------------------------|
| 15 | 532 40 11-46 | Decal, Warning Service/Fire |
| 17 | 532 14 08-37 | Decal, Saddle Brake Parking |
| 20 | 532 16 69-60 | Decal, Bypass Fender CRD |
| 21 | 532 16 62-86 | Decal, Hex Belt Sch 92 CRD |
| -- | 532 18 04-35 | Decal, Rear Plate CRD Symbols |
| -- | 532 13 83-11 | Deck Lift |
| -- | 532 18 19-17 | Pad Footrest RH |
| -- | 532 18 19-16 | Pad Footrest LH |
| -- | 532 40 91-31 | Manual Operator's (Euro) |

WHEELS & TIRES

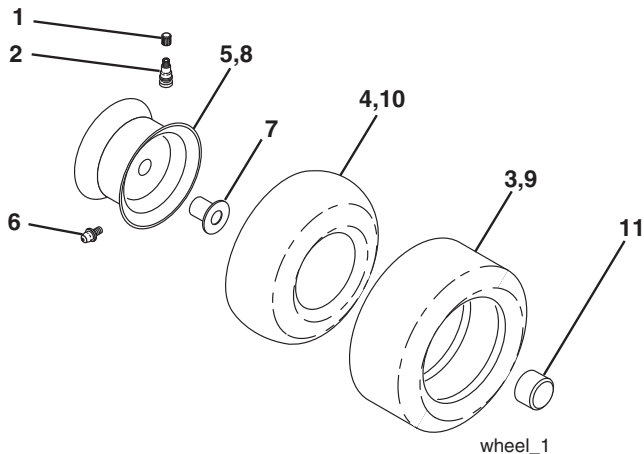

| KEY NO. | PART NO. | DESCRIPTION |
|---------|--------------|---------------------------------|
| 1 | 532 05 91-92 | Cap Valve Tire |
| 2 | 532 06 51-39 | Stem Valve |
| 3 | 532 10 62-22 | Tire F Ts 15 x 6 0-6 Service |
| 4 | 532 05 99-04 | Tube Inner Front #35060 |
| 5 | 532 13 83-36 | Rim Asm 6" Front Silver Service |
| 6 | 532 12 49-57 | Fitting Grease |
| 7 | 532 12 49-59 | Bearing Flange |
| 8 | 532 13 83-37 | Rim Asm 8" Rear Silver Service |
| 9 | 532 12 20-82 | Tire R Ts 20 x 10-8 Service |
| 10 | 532 12 49-26 | Tube Rear 9 5 x 8 Service |
| 11 | 532 17 50-39 | Cap Axle Blk 1 50 x 1 00 |
| -- | 532 14 43-34 | Sealant, Tire (10 oz. tube) |

NOTE: All component dimensions given in U.S. inches
1 inch = 25.4 mm

TRACTOR - - MODEL NO. CTH200 TWIN (96061022701), PRODUCT NO. 960 61 02-27 SCHEMATIC **38**

SCH05

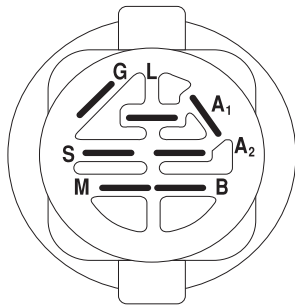
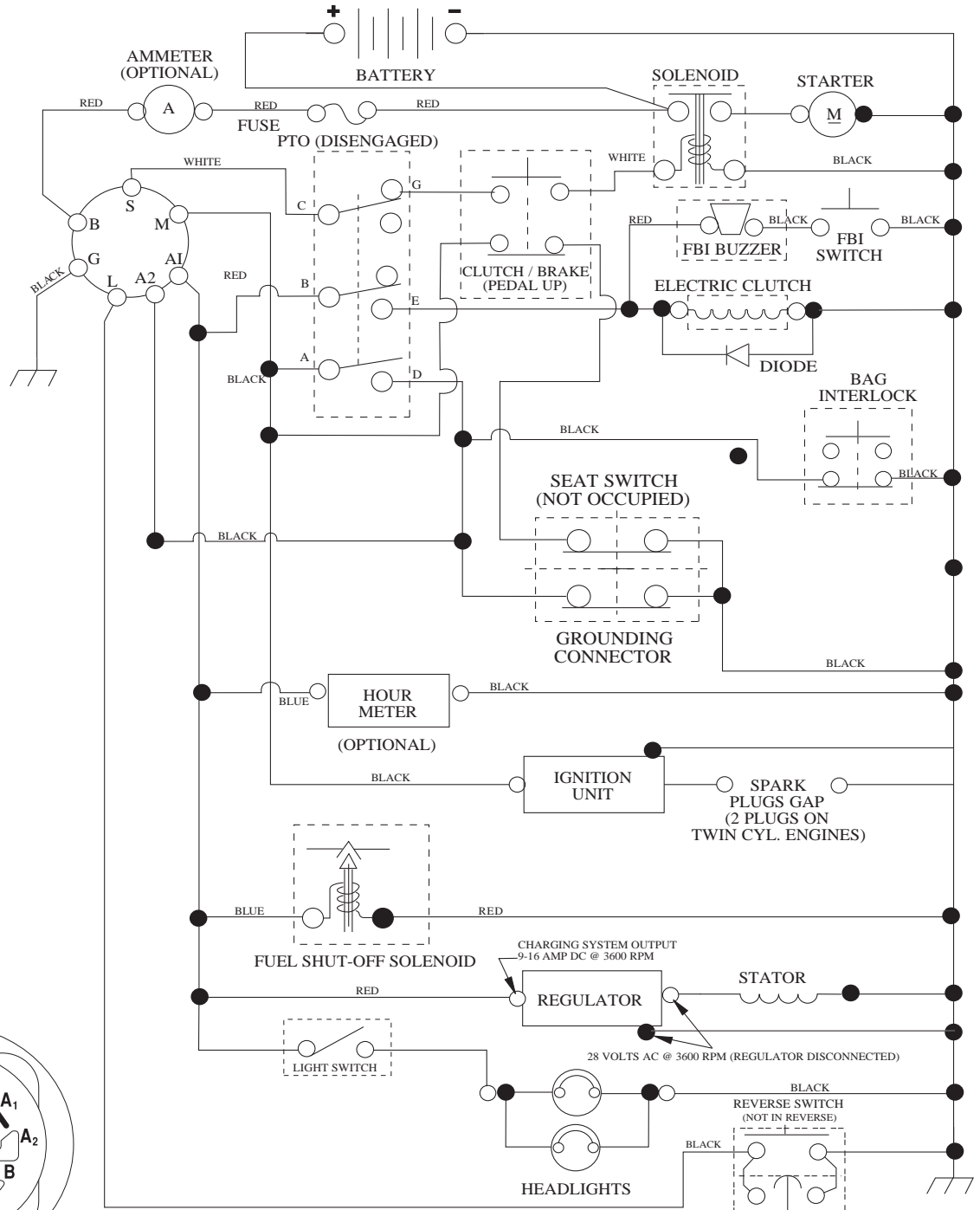

IGNITION SWITCH

| POSITION | CIRCUIT | "MAKE" |
|--------------|------------|--------|
| OFF | M+G+A1 | |
| RUN/OVERRIDE | B+A1 | |
| RUN | B+A1 | L+A2 |
| START | B + S + A1 | |

03048

WIRING INSULATED CLIPS
NOTE: IF WIRING INSULATED CLIPS WERE REMOVED FOR SERVICING OF UNIT, THEY SHOULD BE RE-INSTALLED TO PROPERLY SECURE YOUR WIRING.

PTO SWITCH

| POSITION | CIRCUIT |
|----------|---------------------|
| OFF | C + G, B + H |
| ON | C + F, B + E, A + D |

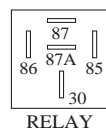

RELAY

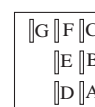

●
NON-REMOVABLE CONNECTIONS

○
REMOVABLE CONNECTIONS

TRACTOR - - MODEL NO. CTH200 TWIN (96061022701), PRODUCT NO. 960 61 02-27
 ELECTRICAL **32**

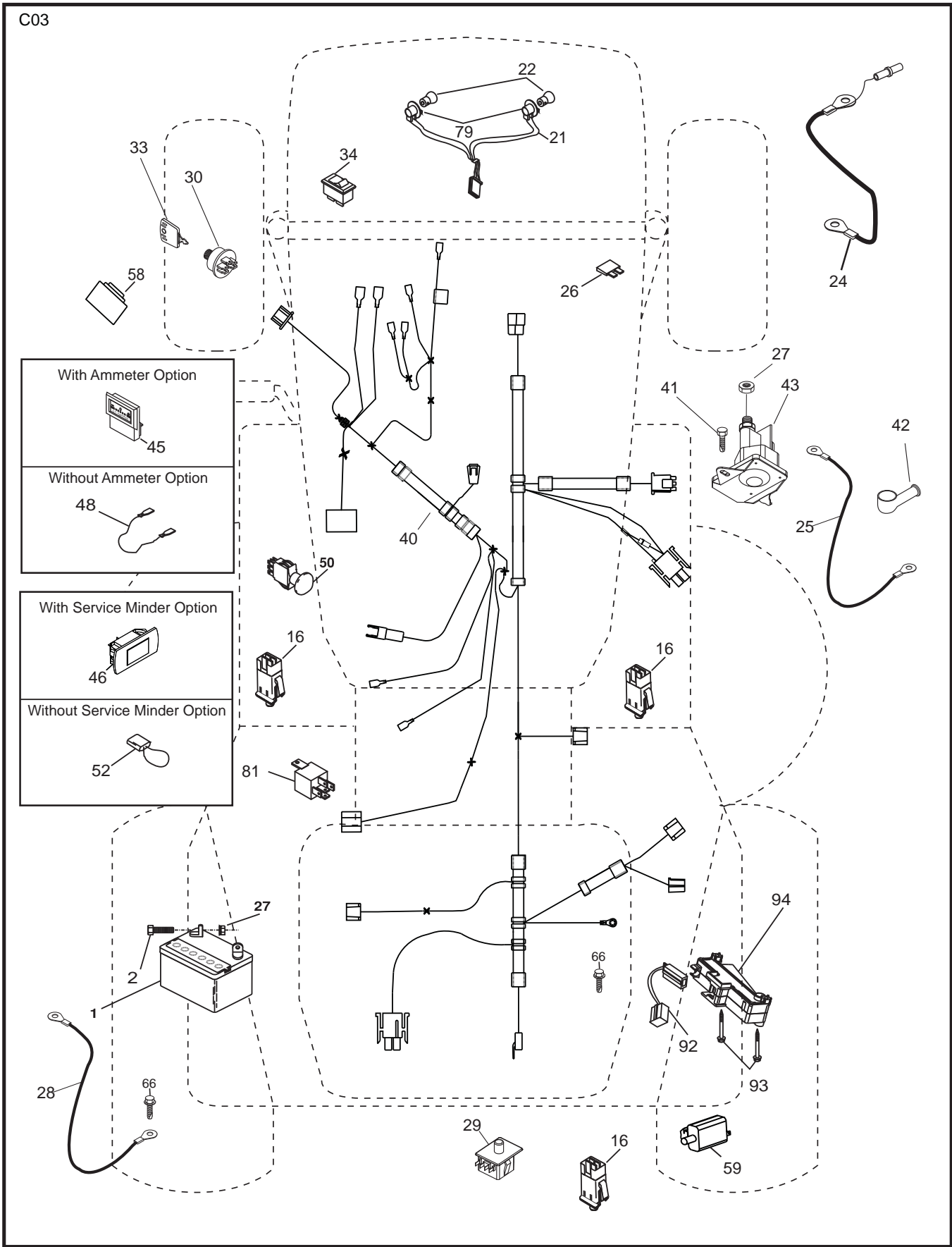

**TRACTOR - - MODEL NO. CTH200 TWIN (96061022701), PRODUCT NO. 960 61 02-27
ELECTRICAL 32**

| KEY NO. | PART NO. | DESCRIPTION |
|----------------|-----------------|-----------------------------------|
| 1 | 532 16 34-65 | Battery |
| 2 | 874 76 04-12 | Bolt Hex Hd 1/4-20 unc x 3/4 |
| 16 | 532 17 61-38 | Switch Interlock |
| 21 | 532 18 37-59 | Harness Asm Light w/4152J |
| 22 | 532 00 41-52 | Bulb Light #1156 |
| 24 | 532 10 84-23 | Cable Starter 6 Ga. 11" Red |
| 25 | 532 16 59-87 | Cable Battery CRD 56" Red |
| 26 | 532 17 51-58 | Fuse |
| 27 | 873 51 04-00 | Nut Keps Hex 1/4-20 unc |
| 28 | 532 12 77-25 | Cable Ground 6 Ga. 18" Black |
| 29 | 532 19 27-49 | Switch Seat |
| 30 | 532 19 33-50 | Switch Ignition |
| 33 | 532 41 19-35 | Key/Chain |
| 34 | 532 11 07-12 | Switch Light |
| 40 | 532 19 74-34 | Harness Ignition |
| 41 | 871 11 04-08 | Bolt Flk Fin Hex 1/4-20 unc x 1/2 |
| 42 | 532 13 15-63 | Cover Terminal Red |
| 43 | 532 19 25-07 | Solenoid |
| 46 | 532 41 39-31 | Service Minder Hourmeter |
| 48 | 532 14 08-44 | Adapter Ammeter Rectangular |
| 50 | 532 17 46-51 | Switch PTO |
| 58 | 532 16 94-19 | Buzzer CRD |
| 59 | 532 18 03-79 | Switch FBI CRD |
| 66 | 817 49 06-08 | Screw Thdrol 3/8-16 x 1/2 Ty-Tt |
| 79 | 532 17 52-42 | Socket Asm. Bulb Twistlock |
| 81 | 532 10 97-48 | Relay Asm |
| 92 | 532 19 66-15 | Harness Pigtail |
| 93 | 532 19 25-40 | Screw Plastite 10-44 x 2.0 |
| 94 | 532 19 18-34 | Module Reverse |

NOTE: All component dimensions given in U.S. inches.
1 inch = 25.4 mm.

TRACTOR - - MODEL NO. CTH200 TWIN (96061022701), PRODUCT NO. 960 61 02-27
CHASSIS AND ENCLOSURES **39**

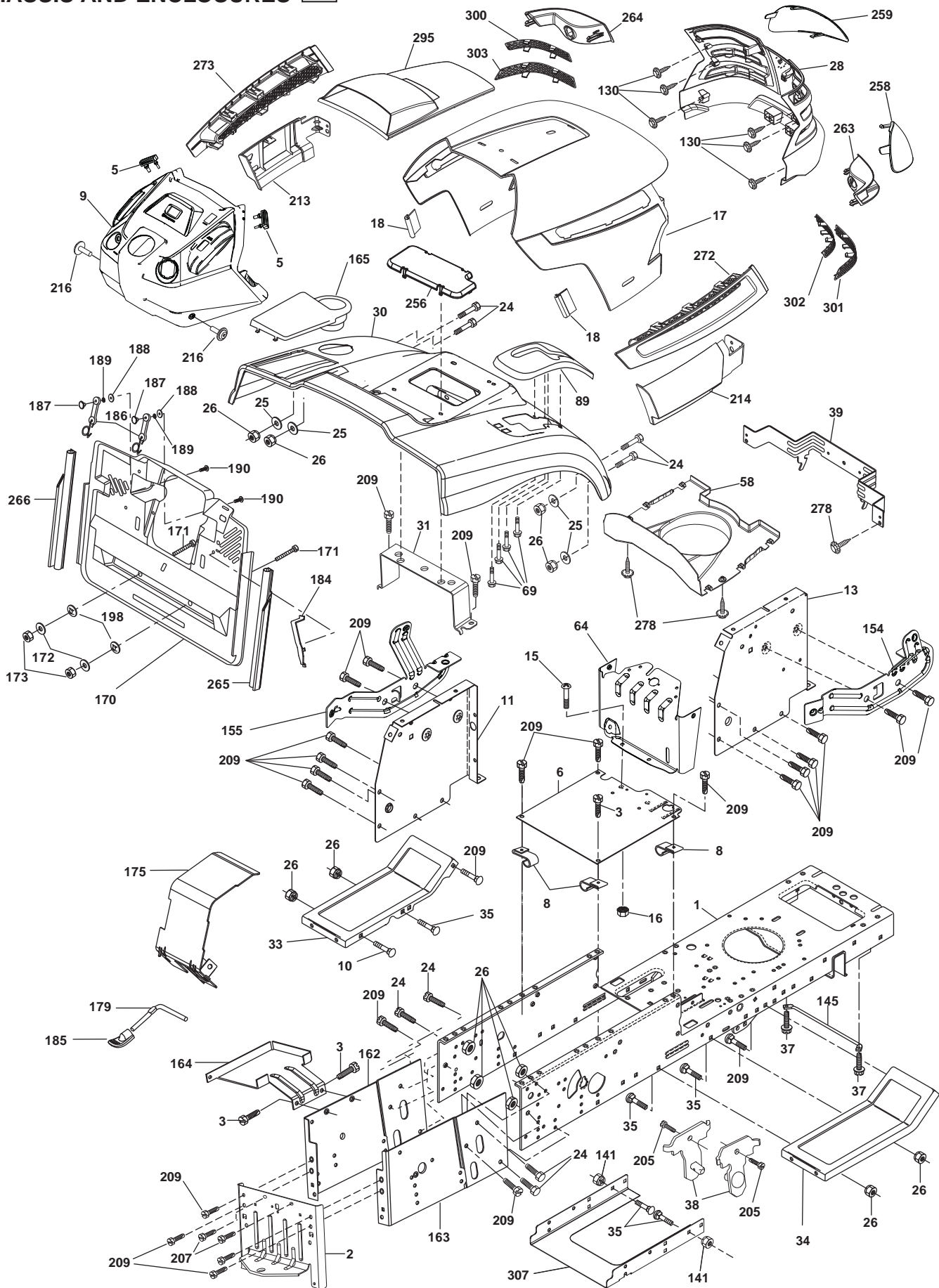

**TRACTOR - - MODEL NO. CTH200 TWIN (96061022701), PRODUCT NO. 960 61 02-27
CHASSIS AND ENCLOSURES **39****

| KEY NO. | PART NO. | DESCRIPTION | KEY NO. | PART NO. | DESCRIPTION |
|---------|--------------|---------------------------------------|---------|--------------|-------------------------------------|
| 1 | 532 17 46-20 | Chassis | 164 | 532 16 56-05 | Support Battery CRD |
| 2 | 532 18 03-84 | Drawbar | 165 | 532 18 11-00 | Cover Battery |
| 3 | 817 06 06-12 | Screw 3/8-16 x 3/4 | 170 | 532 19 94-88 | Backplate CRD |
| 5 | 532 40 75-90 | Bumper Hood | 171 | 872 14 06-20 | Bolt Rdhd Sqnk 3/8-16 x 2-1/2 Gr. 5 |
| 6 | 532 18 44-19 | Saddle | 172 | 819 13 20-16 | Washer 13/32 x 1-1/4 x 16 Ga. |
| 8 | 532 12 64-71 | Clip Insulator 13/32 Mtg. Hole | 173 | 873 51 06-00 | Nut, Keps Hex 3/8-16 unc |
| 9 | 532 40 89-11 | Dash Upper | 175 | 532 18 82-03 | Guard Trap |
| 10 | 872 14 06-08 | Bolt, Carriage 3/8-16 x 3/4 | 179 | 532 18 82-02 | Rod Pivot FBI CRD |
| 11 | 532 16 72-03 | Panel, Dash, LH | 184 | 532 17 46-62 | Bracket Actuator Bagger CRD |
| 13 | 532 17 82-98 | Panel, Asm. Dash RH | 185 | 532 18 11-01 | Knob Rod Brake Parking |
| 15 | 874 18 05-12 | Screw, Machine, THD 5/16-18 unc x 3/4 | 186 | 532 16 07-93 | Latch Asm Mulch/Bagger |
| 16 | 873 51 05-00 | Nut Keps 5/16-18 unc | 187 | 532 12 50-04 | Nut Weld |
| 17 | 532 41 10-46 | Hood | 188 | 819 06 12-16 | Washer #10 |
| 18 | 532 40 47-42 | Bumper Hood | 189 | 810 07 10-00 | Washer Lock #10 |
| 24 | 874 78 06-16 | Bolt | 190 | 871 08 10-10 | Screw Pan Hd Phillip 10-24 x 5/8 |
| 25 | 819 13 13-12 | Washer 13/32 x 13/16 x 12 Ga. | 198 | 532 16 89-37 | Nut, Push |
| 26 | 873 80 06-00 | Nut | 205 | 817 49 06-08 | Screw Thdrol 3/8-16 x 1/2 |
| 28 | 532 40 86-07 | Grille/Lens Asm | 207 | 817 67 05-08 | Screw Thdrol 5/16-18 x 1/2 |
| 30 | 532 19 73-76 | Fender | 209 | 817 00 06-12 | Screw Hex Wsh Thdrol 3/8-16 |
| 31 | 532 16 51-56 | Bracket, Fender Support | 213 | 532 40 17-11 | Skirt Side LH |
| 33 | 532 18 10-57 | Footrest, LH | 214 | 532 40 17-09 | Skirt Side RH |
| 34 | 532 18 10-58 | Footrest, RH | 256 | 532 18 13-61 | Cover Fender Rack |
| 35 | 872 11 06-06 | Bolt | 263 | 532 19 71-98 | Bezel RH |
| 37 | 817 49 05-08 | Screw Thdrol 5/16-18 x 1/2 TYT | 264 | 532 19 71-99 | Bezel LH |
| 38 | 532 18 17-48 | Bracket Asm Pivot Mower Rear | 265 | 532 18 57-04 | Seal RH Side Bagger |
| 39 | 532 41 02-50 | Bracket Pivot Hood | 266 | 532 18 57-03 | Seal LH Side Bagger |
| 42 | 532 19 89-07 | Lens LH | 272 | 532 40 30-48 | Vent Hood RH |
| 43 | 532 19 89-06 | Lens RH | 273 | 532 40 30-76 | Vent Hood LH |
| 58 | 532 19 85-12 | Duct Air | 278 | 532 41 63-58 | Screw #10 x .750 BOS Thread |
| 64 | 532 19 93-95 | Dash Lower | 295 | 532 41 66-15 | Vent Top Hood |
| 69 | 532 14 24-32 | Screw Hx Wsh Hi-Lo 1/4-1/2 | 300 | 532 19 91-31 | Insert Hex Top LH |
| 89 | 532 19 73-77 | Console CRD Auto Grey | 301 | 532 19 91-30 | Insert Hex Top RH |
| 141 | 873 90 06-00 | Nut | 302 | 532 19 91-32 | Insert Hex Bottom RH |
| 145 | 532 40 91-67 | Rod Pivot Chassis/Hood | 303 | 532 19 91-33 | Insert Hex Bottom LH |
| 154 | 532 40 86-90 | Bracket Mounting Dash RH | 304 | 817 06 04-10 | Hex Tapping Screw |
| 155 | 532 40 86-91 | Bracket Mounting Dash LH | 307 | 532 42 09-19 | Shield Chassis Front |
| 162 | 532 18 03-82 | Bracket Exten Chassis LH CRD | | | |
| 163 | 532 18 03-83 | Bracket Exten Chassis RH CRD | | | |

NOTE: All component dimensions given in U.S. inches.
1 inch = 25.4 mm.

TRACTOR - - MODEL NO. CTH200 TWIN (96061022701), PRODUCT NO. 960 61 02-27
DRIVE **40**

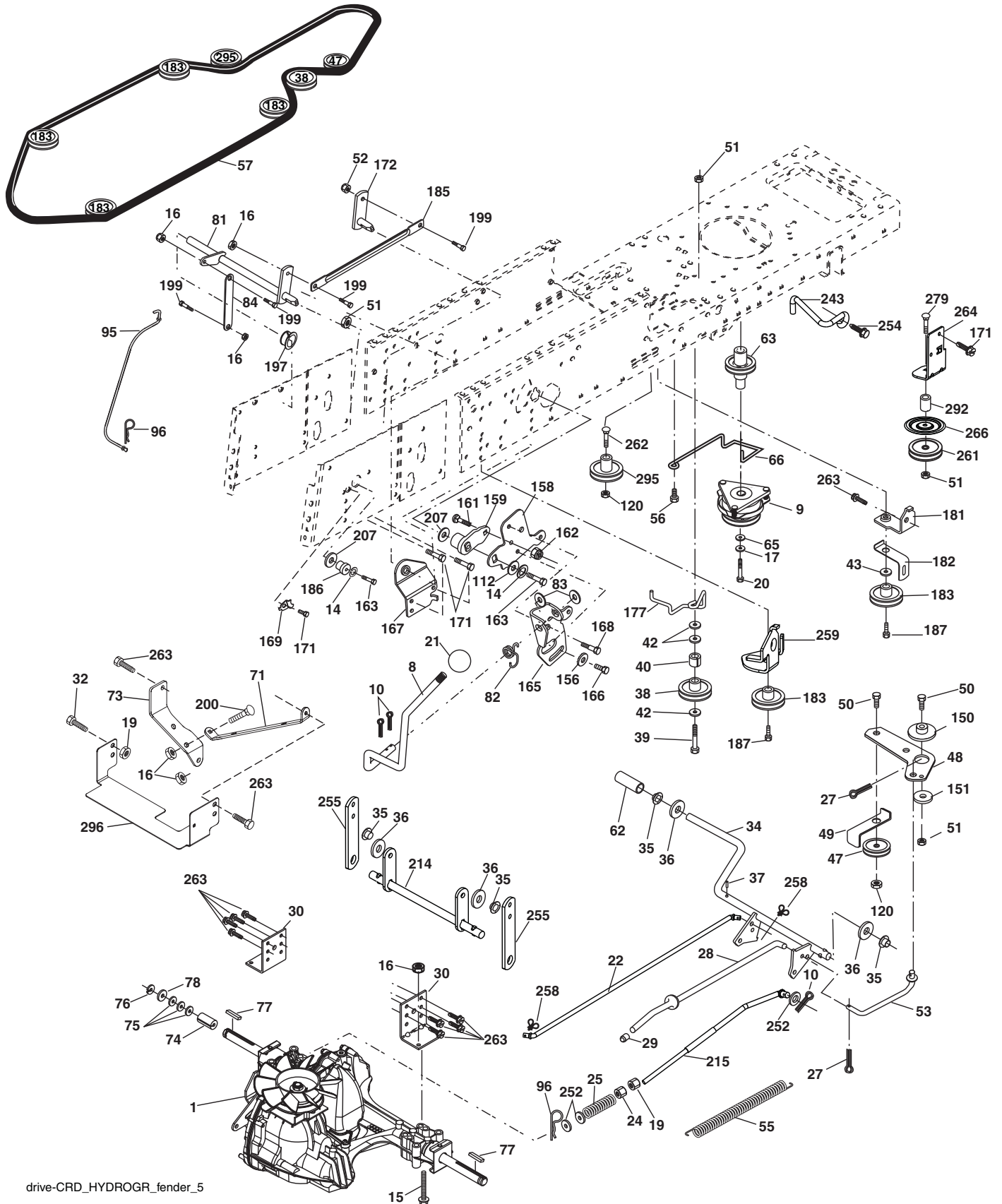

drive-CRD_HYDROGR_fender_5

**TRACTOR - - MODEL NO. CTH200 TWIN (96061022701), PRODUCT NO. 960 61 02-27
DRIVE **40****

| KEY NO. | PART NO. | DESCRIPTION | KEY NO. | PART NO. | DESCRIPTION |
|---------|--------------|-------------------------------------|---------|--------------|-----------------------------------|
| 1 | ----- | Transaxle Hydro Gear 321-0510 | 84 | 532 17 00-07 | Link, Transaxle |
| 8 | 532 19 27-06 | Rod, Shift Fender Adjust Lt | 95 | 532 17 00-15 | Control Asm Bypass Hydro |
| 9 | 532 19 81-43 | Clutch Elect | 96 | 532 12 47-88 | Spring, Retainer 1" |
| 10 | 876 02 04-16 | Pin, Cotter 1/8 x 1 | 112 | 819 09 12-10 | Washer 9/32 x 3/4 x 10 Ga. |
| 14 | 810 04 04-00 | Washer, Lock Hvy Helical | 120 | 873 90 06-00 | Nut Lock Flg. 3/8-16 unc |
| 15 | 874 49 05-44 | Bolt Hex FGHD 5/16-18 x Gr. 5 | 150 | 532 16 58-50 | Bushing, Bellcrank Grnd Dr |
| 16 | 873 80 05-00 | Nut Lock Hex w/lns 5/16-18 unc | 151 | 819 13 32-10 | Washer 13/32 x 2 x 10 Ga. |
| 17 | 532 12 61-97 | Washer 1-1/2 OD x 15/32 ID x .250 | 156 | 532 16 60-02 | Washer Srrted 5/16 ID x 1.125 |
| 19 | 873 80 06-00 | Nut Lock Hex w/lns 3/8-16 unc | 158 | 532 16 55-89 | Bracket Shift Mount |
| 20 | 532 17 39-37 | Bolt Hex 7/16-20 x 4 x Gr. 5-1.5 | 159 | 532 18 39-00 | Hub Shift |
| 21 | 532 12 12-74 | Knob Duckhead 1/4-13 unc Blk | 161 | 872 14 04-06 | Bolt Rdhd Sqnk 1/4-20 x 3/4 Gr. 5 |
| 22 | 532 17 56-07 | Brake Rod | 162 | 873 68 04-00 | Nut Crownlock 1/4-20 unc |
| 24 | 873 35 06-00 | Nut Hex Jam 3/8-16 unc | 163 | 874 78 04-16 | Bolt Hex Fin 1/4-20 unc x 1 Gr. 5 |
| 25 | 532 19 20-36 | Spring, Rod, Brake | 165 | 532 16 56-23 | Bracket Pivot Lever |
| 27 | 876 02 04-12 | Pin, Cotter 1/8 x 3/4 | 166 | 817 49 05-10 | Screw 5/16-18 x 5/8 |
| 28 | 532 17 57-65 | Rod, Parking Brake | 167 | 532 16 55-88 | Bracket Support Shift CRD |
| 29 | 532 12 42-36 | Cap, Parking Brake | 168 | 532 16 54-92 | Bolt Shoulder 5/16-18 x .561 |
| 30 | 532 16 95-92 | Bracket, Mfg. Transaxle | 169 | 532 16 55-80 | Plate Fastening Lt |
| 32 | 872 11 06-08 | Bolt RDHD SQNK 3/8-16 x 1 Gr. 5 | 171 | 817 49 06-08 | Screw Thdrol 3/8-16 x 1/2 Ty-Tt |
| 34 | 532 17 55-78 | Shaft, Asm Pedal Foot CRD | 172 | 532 17 02-71 | Shaft Asm Shifter Frt CRD |
| 35 | 532 12 01-83 | Bearing, Nylon | 177 | 532 16 59-32 | Keeper Flat Idler 3.06" CRD |
| 36 | 819 21 16-16 | Washer 21/32 x 1 x 16 Ga. | 181 | 532 18 02-11 | Bracket Idler Ground Drive CRD |
| 37 | 532 12 49-63 | Pin, Roll 3/16 x 1" | 182 | 532 18 26-82 | Keeper Belt 2.5" OD V-Idler CRD |
| 38 | 532 16 59-36 | Pulley Flat Composite 3.06" | 183 | 532 19 95-32 | Pulley V-Idler 2.50" OD CRD |
| 39 | 874 76 06-44 | Bolt Fin Hex 3/8-16 unc x 2-3/4 | 185 | 532 17 00-08 | Link Shift |
| 40 | 532 12 49-65 | Spacer, Split 395 x 59 Bzp | 186 | 532 16 56-14 | Hub Tapered Round CRD |
| 42 | 819 13 13-12 | Washer 13/32 x 13/16 x 12 Ga. | 187 | 817 58 05-20 | Screw Thdrol 5/16-18 x 1.25 |
| 43 | 819 11 10-12 | Washer 11/32 x 5/8 x 12 Ga. | 197 | 532 16 96-13 | Nyliner Snap-In 5/8 |
| 47 | 532 12 77-83 | Pulley, Idler, V Groove Plastic | 199 | 532 16 96-12 | Bolt Shoulder 5/16-18 unc |
| 48 | 532 15 44-07 | Bellcrank Clutch Grnd Drv | 200 | 872 14 05-08 | Bolt RDHD SQNK 5/16-18 x 1 |
| 49 | 532 12 32-05 | Retainer, Belt Style Spring | 207 | 532 16 98-45 | Washer Nylon Rear |
| 50 | 872 11 06-12 | Bolt Carr. Sh. 3/8-16 x 1-1/2 Gr. 5 | 214 | 532 17 56-09 | Shaft Asm. Brake |
| 51 | 873 68 06-00 | Nut, Crownlock 3/8-16 unc | 215 | 532 17 56-52 | Rod Brake Hydro |
| 52 | 873 68 05-00 | Nut Crownlock 5/16-18 | 243 | 532 19 07-36 | Bracket Anti-Rotation |
| 53 | 532 19 96-52 | Link, Clutch 7.66 | 252 | 819 13 16-16 | Washer 13/32 x 1 x 16 Ga. |
| 55 | 532 10 57-09 | Spring, Return, Clutch | 255 | 532 17 56-08 | Brace Shaft Brake Mtg. |
| 56 | 817 06 06-20 | Screw 3/8-16 x 1-1/4 | 258 | 532 17 80-62 | Clip Retainer |
| 57 | 532 17 01-40 | V-Belt Kev 112" 0650 CRD | 259 | 532 18 02-12 | Bracket Pulley |
| 62 | 532 12 48-72 | Cover, Pedal | 261 | 532 13 14-94 | Pulley Idler Flat |
| 63 | 532 18 03-97 | Pulley Engine CVX | 262 | 872 11 06-22 | Bolt Carr. 3/8-16 x 2-3/4 Gr. 5 |
| 65 | 810 04 07-00 | Washer | 263 | 817 00 06-12 | Screw 3/8-16 x 3/4 |
| 66 | 532 15 47-78 | Keeper, Belt Engine F-Proof | 264 | 532 19 76-07 | Bracket Idler Chassis |
| 71 | 532 16 91-83 | Strap, Torque, LH | 266 | 532 18 20-61 | Shield Idler Mower |
| 73 | 532 16 91-82 | Strap, Torque, RH | 279 | 872 11 06-16 | Bolt RD HD SQ 3/8-16 unc x 2 |
| 74 | 532 13 70-57 | Spacer, Split | 292 | 532 40 02-71 | Spacer Noram CRD |
| 75 | 532 12 17-49 | Washer 25/32 x 1-1/4 x 16 Ga. | 295 | 532 17 91-14 | Pulley Idler Composite |
| 76 | 812 00 00-01 | Ring, E | 296 | 532 42 09-20 | Shield Chassis Rear |
| 77 | 532 12 35-83 | Key, Square | | | |
| 78 | 532 12 17-48 | Washer 25/32 x 1-5/8 x 16 Ga. | | | |
| 81 | 532 17 00-06 | Asm, Shaft, Cross Rear | | | |
| 82 | 532 16 57-11 | Spring, Torsion | | | |
| 83 | 819 17 12-16 | Washer 17/32 x 3/4 x 16 Ga. | | | |

NOTE: All component dimensions given in U.S. inches
1 inch = 25.4 mm

**TRACTOR - - MODEL NO. CTH200 TWIN (96061022701), PRODUCT NO. 960 61 02-27
ENGINE 24**

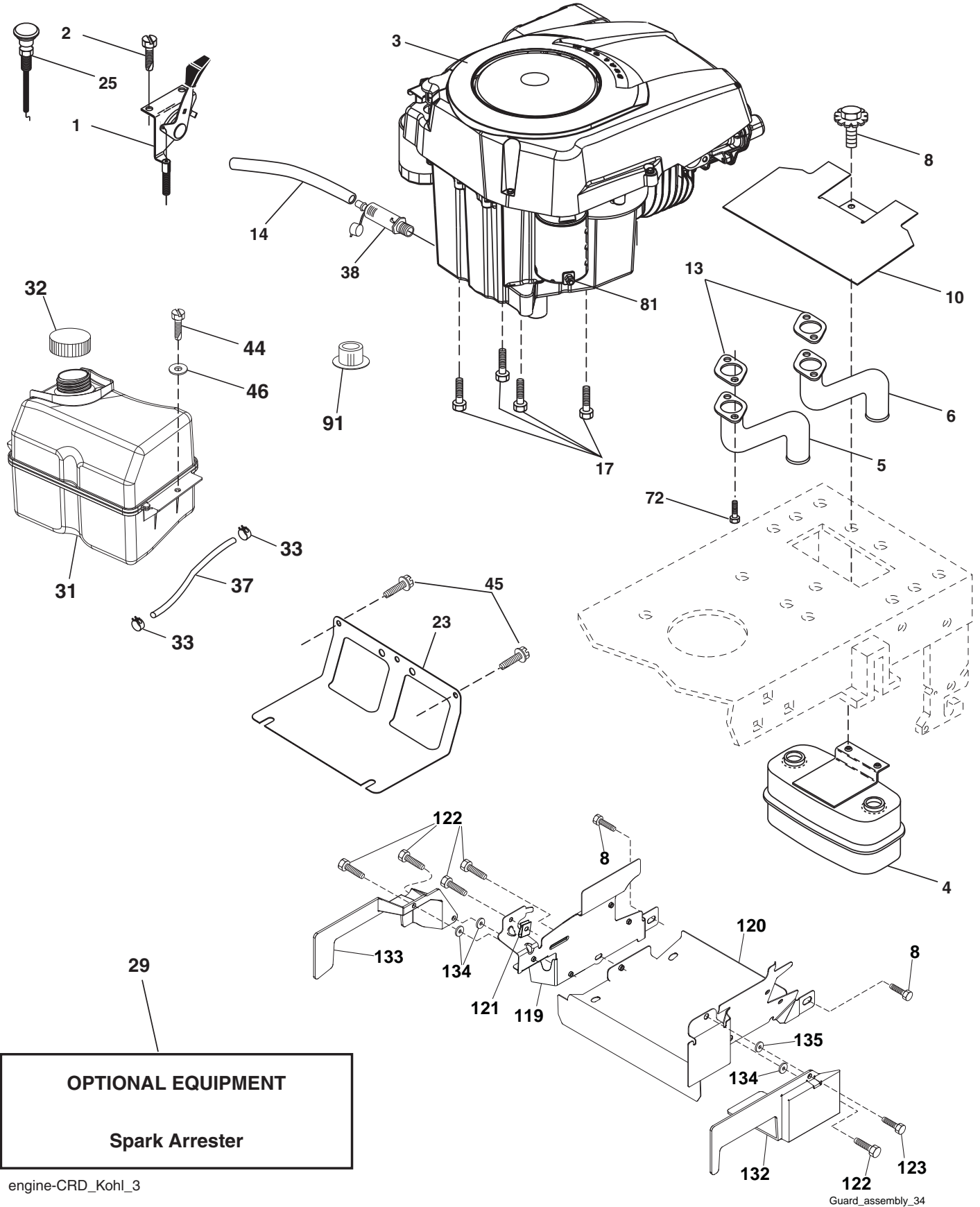

**TRACTOR - - MODEL NO. CTH200 TWIN (96061022701), PRODUCT NO. 960 61 02-27
ENGINE 24**

| KEY NO. | PART NO. | DESCRIPTION |
|----------------|-----------------|----------------------------------|
| 1 | 532 18 29-37 | Control Throt |
| 2 | 532 41 63-58 | Screw Hex 10 x .750 BOS Thread |
| 3 | --- -- ---- | Engine Kohler SV710 |
| 4 | 532 14 97-23 | Muffler Exhaust |
| 5 | 532 14 66-99 | Tube, Exhaust LH |
| 6 | 532 14 67-00 | Tube, Exhaust RH |
| 8 | 532 17 18-77 | Bolt 5/16-18 x 3/4 |
| 10 | 532 14 66-29 | Shield Browning Intek |
| 13 | --- -- ---- | Gasket |
| 14 | 532 14 84-56 | Tube Drain Oil Easy |
| 17 | 817 12 06-16 | Screw 3/8-16 |
| 23 | 532 16 98-37 | Shield Browning/Debris Guard |
| 25 | 532 18 95-41 | Choke Control |
| 29 | 532 13 71-80 | Arrestor Spark |
| 31 | 532 40 74-89 | Tank Fuel |
| 32 | 532 19 77-25 | Cap Asm Fuel Top |
| 33 | 532 12 34-87 | Clamp Hose Blk |
| 37 | 532 13 70-40 | Line Fuel 20" |
| 38 | 532 18 16-54 | Plug Drain Oil Easy |
| 44 | 817 67 04-12 | Screw Hexwsh Thdrol 1/4-20 x 3/4 |
| 45 | 817 00 06-12 | Screw Hexwsh Thdr 3/8-16 x 3/4 |
| 46 | 819 09 14-16 | Washer 9/32 x 7/8 x 16 Ga. |
| 72 | 532 19 23-34 | Screw Socket HD 5/16-18 x .75 |
| 81 | 873 51 04-00 | Nut Keps 1/4-20 unc |
| 91 | 532 18 74-95 | Bushing |
| 119 | 532 19 97-68 | Guard Asm. Engine LH |
| 120 | 532 19 97-67 | Guard Asm. Engine RH |
| 121 | 532 19 66-88 | Clip Threaded |
| 122 | 532 13 77-29 | Screw 1/4-20 x 5/8 |
| 123 | 817 67 05-08 | Screw 5/16-18 x 1/2 |
| 132 | 532 42 07-57 | Shield Side RH |
| 133 | 532 42 07-56 | Shield Side LH |
| 134 | 532 42 30-62 | 1/4 PAL Nut |
| 135 | 532 42 30-63 | 5/16 PAL Nut |

NOTE: All component dimensions given in U.S. inches
1 inch = 25.4 mm

TRACTOR - - MODEL NO. CTH200 TWIN (96061022701), PRODUCT NO. 960 61 02-27
 STEERING ASSEMBLY **41**

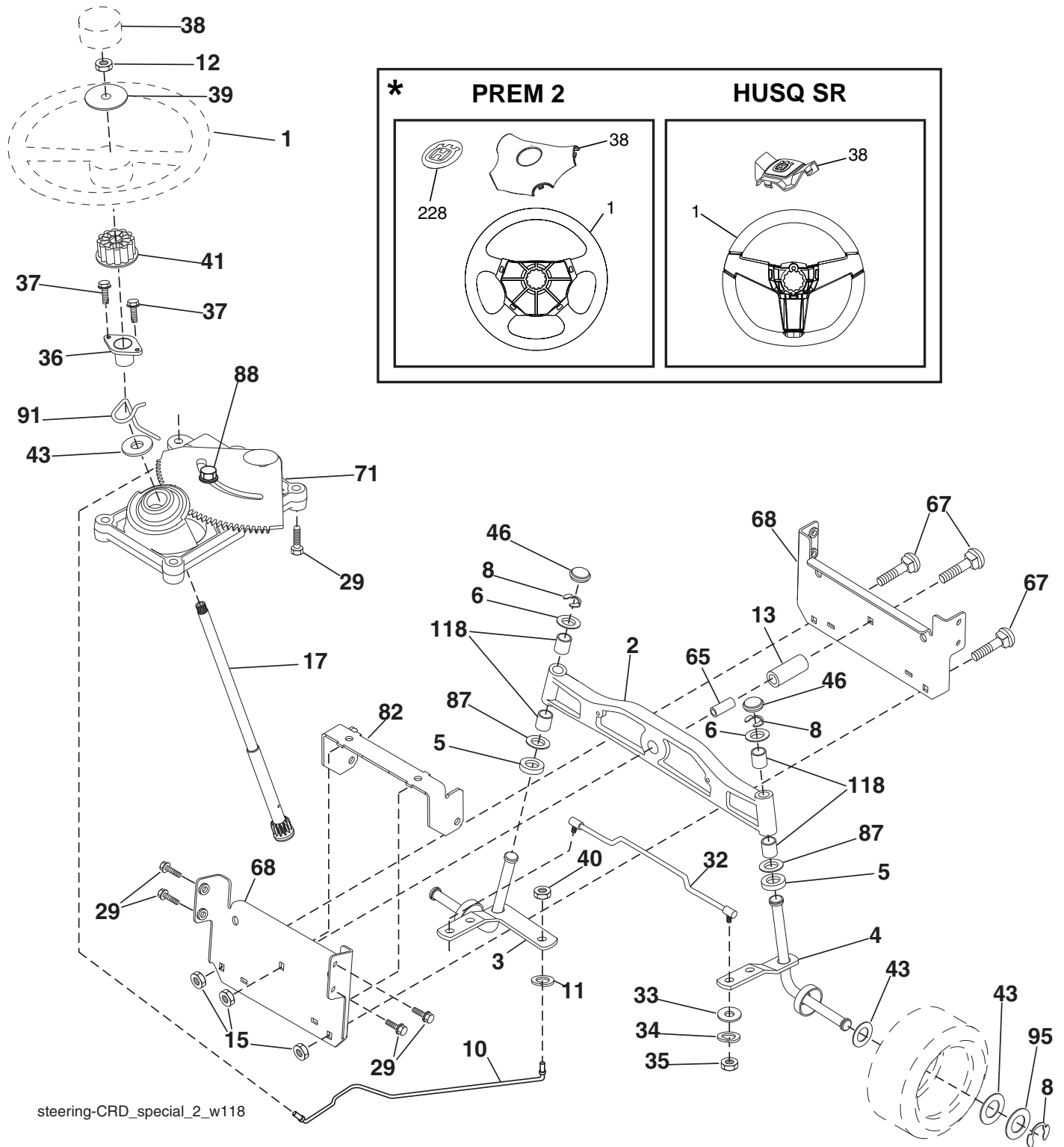

steering-CRD_special_2_w118

**TRACTOR - - MODEL NO. CTH200 TWIN (96061022701), PRODUCT NO. 960 61 02-27
STEERING ASSEMBLY **41****

| KEY NO. | PART NO. | DESCRIPTION |
|----------------|-----------------|------------------------------------|
| 1 | 532 41 64-80 | Wheel Steering Husq SR |
| -- | 532 19 36-51 | Wheel Steering Prem 2 |
| 2 | 532 19 35-42 | Axle Asm Cast Iron Lt |
| 3 | 532 16 98-40 | Spindle Assembly, LH |
| 4 | 532 16 98-39 | Spindle Assembly, RH |
| 5 | 532 12 49-31 | Washer, Thrust, |
| 6 | 532 12 17-48 | Washer 25/32 x 1-5/8 x 16 Ga. |
| 8 | 812 00 00-29 | Ring, Klip |
| 10 | 532 17 51-21 | Link, Drag |
| 11 | 810 04 06-00 | Washer, Lock |
| 12 | 873 94 08-00 | Nut Hex Jam Toplock 1/2-20 unf |
| 13 | 532 13 65-18 | Spacer Brg Axle Front |
| 15 | 532 14 52-12 | Nut Hex Flange Lock |
| 17 | 532 17 78-83 | Shaft, Steering |
| 29 | 817 00 06-12 | Screw 3/8-16 x 3/4 |
| 32 | 532 17 18-88 | Rod, Tie |
| 33 | 819 11 12-16 | Washer 11/32 x 3/4 x 16 Ga. |
| 34 | 810 04 05-00 | Washer Lock Hvy Hlcl Spr 5/16 |
| 35 | 873 54 05-00 | Crownlock Nut 5/16-24 unf 3847 |
| 36 | 532 15 51-05 | Bushing, Steering |
| 37 | 532 15 29-27 | Screw TT #10-32 x 5 x 3/8 Flange |
| 38 | 532 41 59-87 | Cap Wheel Steering Husq SR |
| -- | 532 19 36-52 | Cap Wheel Steering Prem 2 |
| 39 | 819 18 38-12 | Washer 9/16 ID x 2-3/8 OD x 12 Ga. |
| 40 | 873 54 06-00 | Nut Lock 3/8-24 |
| 41 | 532 18 67-37 | Adaptor, Steering Wheel |
| 43 | 532 12 17-49 | Washer 25/32 x 1-1/4 x 16 Ga. |
| 46 | 532 12 12-32 | Cap, Spindle |
| 65 | 532 41 47-36 | Spacer Brace Axle |
| 67 | 872 11 06-18 | Bolt Rdhd Sqnk 3/8-16 x 2-1/4 |
| 68 | 532 16 98-27 | Brace Axle |
| 71 | 532 17 51-46 | Steering Asm. |
| 82 | 532 19 99-78 | Bracket Susp Chassis Front |
| 87 | 532 17 39-66 | Washer Flat .781 x 1-1/2 x .14 |
| 88 | 532 17 51-18 | Bolt Shoulder 7/16-20 unc |
| 91 | 532 17 55-53 | Clip Steering |
| 95 | 532 18 89-67 | Washer |
| 118 | 532 40 60-13 | Bushing |
| 228 | 532 40 44-84 | Decal, Wheel, Steering |

NOTE: All component dimensions given in U.S. inches.
1 inch = 25.4 mm.

TRACTOR - - MODEL NO. CTH200 TWIN (96061022701), PRODUCT NO. 960 61 02-27
 MOWER DECK 44

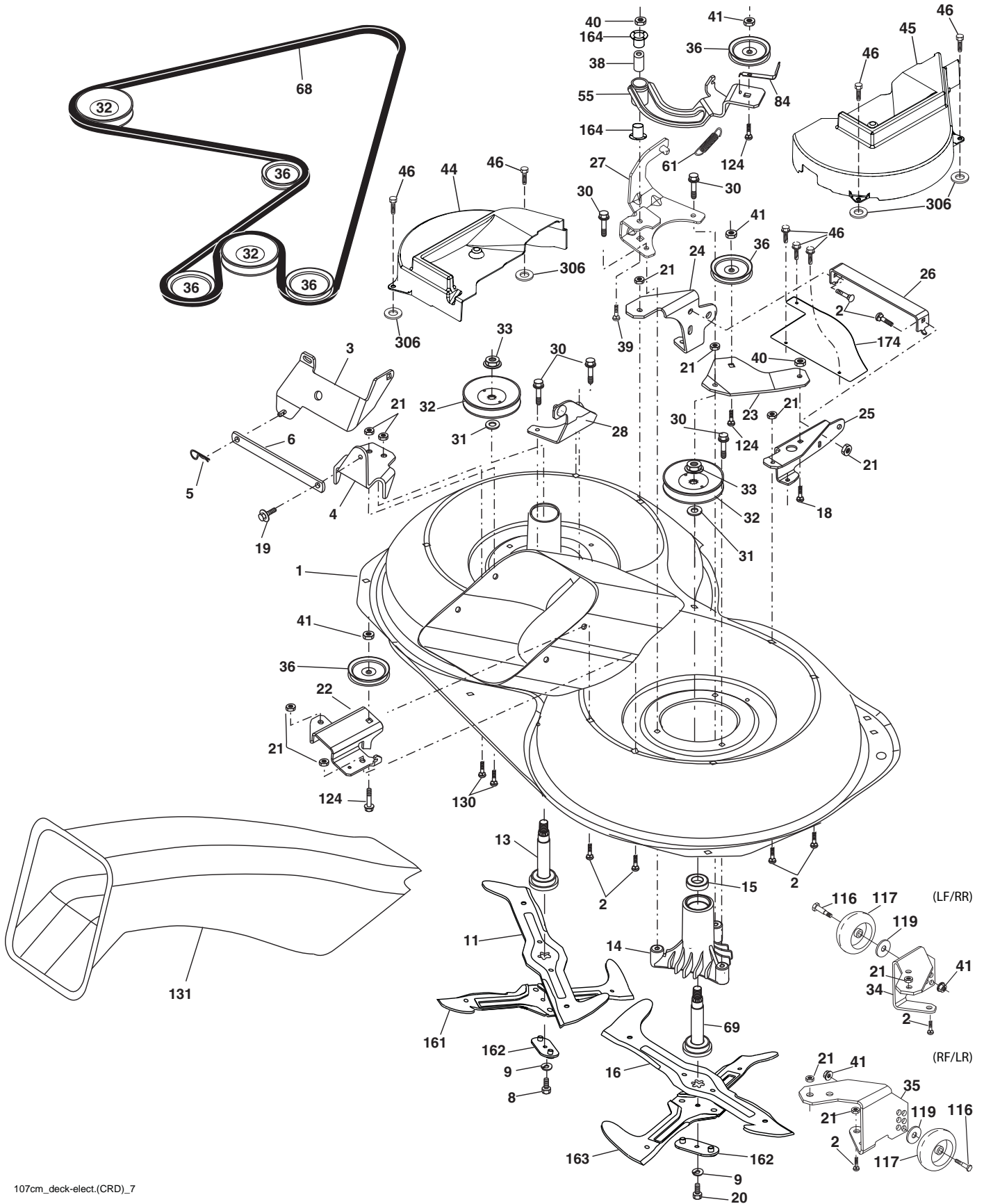

107cm_deck-elect.(CRD)_7

**TRACTOR - - MODEL NO. CTH200 TWIN (96061022701), PRODUCT NO. 960 61 02-27
MOWER DECK 44**

| KEY NO. | PART NO. | DESCRIPTION | KEY NO. | PART NO. | DESCRIPTION |
|------------|--------------|-------------------------------------|------------|--------------|-----------------------------------|
| 1 | 532 16 91-60 | Housing Asm. Mower | 40 | 873 68 06-00 | Nut Crownlock 3/8-16 unc |
| 2 | 872 14 05-06 | Bolt Rdhd Sqnk 5/16-18 unc x 3/4 | 41 | 873 90 06-00 | Nut Flangelock 3/8-16 unc |
| 3 | 532 16 55-69 | Bracket Asm. S-Bar Chass | 44 | 532 42 07-54 | Cover Mandrel LH |
| 4 | 532 16 91-67 | Bracket Bar Sway Deck | 45 | 532 42 07-55 | Cover Mandrel RH |
| 5 | 532 12 46-70 | Retainer Spring | 46 | 532 13 77-29 | Screw Thd Roll 1/4-20 x 5/8 |
| 6 | 532 16 55-57 | Bar Sway | 55 | 532 16 98-49 | Arm Idler |
| 8 | 532 18 17-12 | Bolt 3/8-24 x 1.25 Gr. 8 Patched | 61 | 532 19 94-87 | Spring Tension Belt |
| 9 | 810 03 06-00 | Washer Lock Hvy 3/8 Unplated | 68 | 532 40 20-09 | Hex-Belt Mower Drive |
| 11 | 532 18 05-83 | Blade 3-1 LH | 69 | 532 16 54-82 | Shaft Asm w/Lwr Brg RH Thd CRD |
| 13 | 532 13 76-45 | Shaft Asm. w/Lower Bearing | 84 | 532 15 60-85 | Keeper Belt Idler |
| 14 | 532 12 87-74 | Housing Mandrel Vented (Machd) | 116 | 532 19 34-06 | Bolt Shoulder |
| 15 | 532 11 04-85 | Bearing Ball Mandrel | 117 | 532 17 48-73 | Wheel Gauge |
| 16 | 532 18 05-84 | Blade 3-1 RH | 118 | 873 90 06-00 | Nut Centerlock 3/8-16 unc |
| 18 | 872 11 06-06 | Bolt Rdhd Sqnk 3/8-16 x 3/4 Gr. 5 | 119 | 819 13 20-12 | Washer 3/8 x 7/8 x 14 Ga. |
| 19 | 532 13 28-27 | Bolt Shoulder 5/16-18 Thd Form | 124 | 872 11 06-12 | Bolt Carr Sh 3/8-16 x 1-1/2 Gr. 5 |
| 20 | 532 18 17-13 | Bolt 3/8-24 x 1.25 Gr. 8 Ptch Lhthd | 130 | 872 11 05-06 | Bolt Rdhdsqnk 5/16-18 unc x 3/4 |
| 21 | 873 68 05-00 | Nut Crown Lock 5/16-18 | 131 | 532 16 56-61 | Chute Bagger CRD 92cm |
| 22 | 532 16 91-65 | Bracket Idler Sprt RR | 161 | 532 18 04-24 | Blade Cross LH 107 |
| 23 | 532 16 91-66 | Bracket Idler Sprt RF | 162 | 532 18 08-78 | Adapter Weldment Blade 107 |
| 24 | 532 41 34-36 | Bracket Suspension LF | 163 | 532 18 04-25 | Blade Cross RH 107 |
| 25 | 532 40 01-05 | Bracket Suspension RF | 164 | 532 12 49-37 | Bearing |
| 26 | 532 40 01-10 | Brace Susp Frt CRD | 174 | 532 40 02-40 | Guard Susp. Front |
| 27 | 532 16 91-72 | Bracket Asm. Susp RR | 306 | 532 42 30-62 | 1/4" PALNUT |
| 28 | 532 16 91-68 | Bracket Asm. Susp LR | --- | 532 18 18-57 | Mandrel Asm Service |
| 30 | 532 17 39-84 | Screw Thd Rolling Dod. PT Hex | --- | 532 18 18-58 | Mandrel Asm CRD LH Threads VC |
| 31 | 532 18 76-90 | Washer Spacer Mower Vented | --- | 532 42 27-89 | Replacement Mower Complete |
| 32 | 532 19 81-45 | Mandrel Pulley | | | |
| 33 | 532 40 02-34 | Nut Flg Top Lock | | | |
| 34 | 532 40 01-03 | Bracket Gauge Wheel LF | | | |
| 35 | 532 40 01-04 | Bracket Gauge Wheel RF | | | |
| 36 | 532 14 67-63 | Pulley Idler V-Groove Dim 4.25 | | | |
| 38 | 532 16 98-51 | Spacer Hub Arm Idler | | | |
| 39 | 872 11 06-22 | Bolt RhHd 3/8-16 unc x 2-3/4 Gr. 5 | | | |

NOTE: All component dimensions given in U.S. inches
1 inch = 25.4 mm

TRACTOR - - MODEL NO. CTH200 TWIN (96061022701), PRODUCT NO. 960 61 02-27
MOWER LIFT **45**

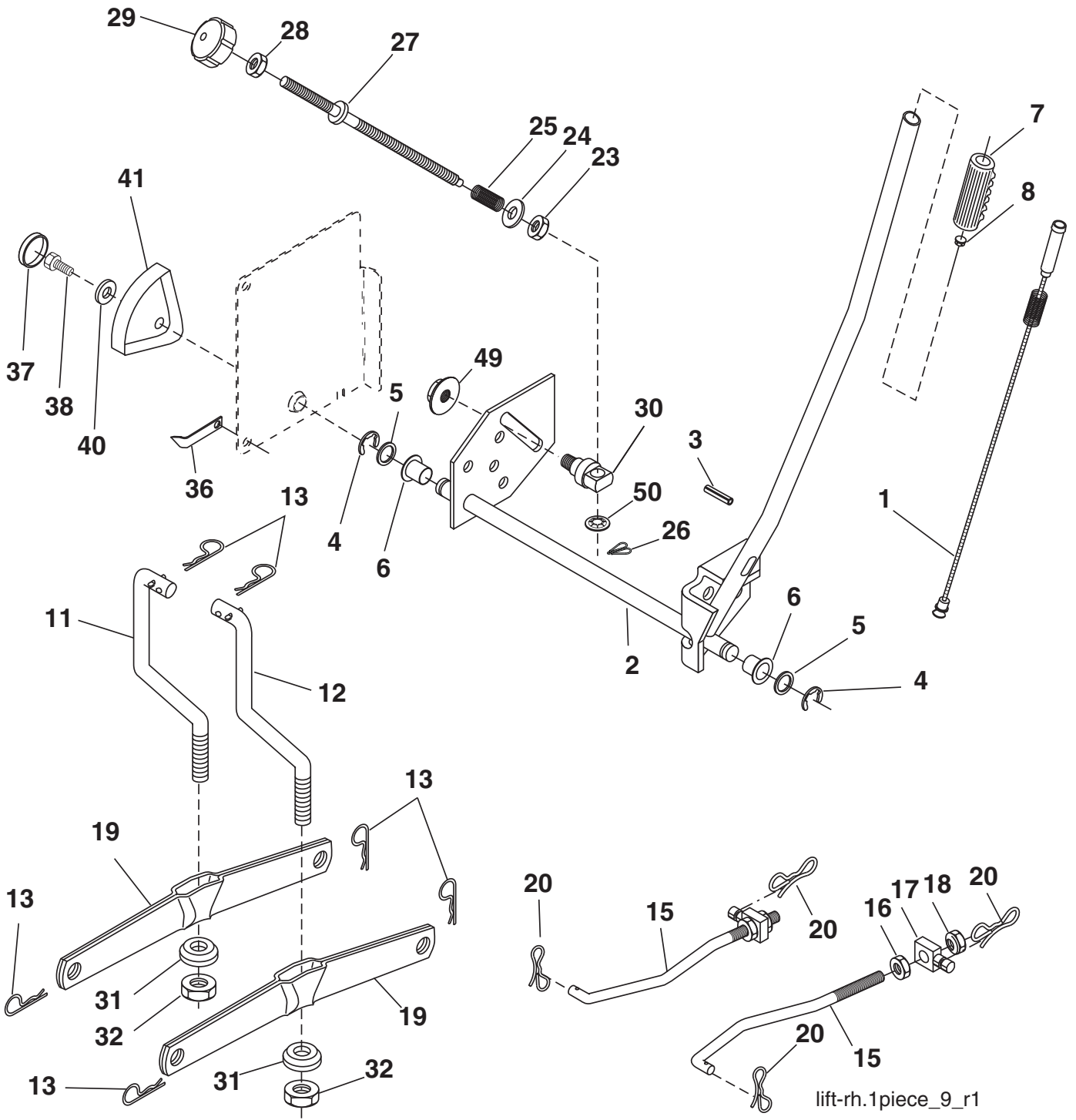

**TRACTOR - - MODEL NO. CTH200 TWIN (96061022701), PRODUCT NO. 960 61 02-27
MOWER LIFT 45**

| KEY NO. | PART NO. | DESCRIPTION |
|----------------|-----------------|-------------------------------|
| 1 | 532 40 50-07 | Plunger Asm Lift Lever |
| 2 | 532 19 80-70 | Shaft Asm. Lift |
| 3 | 532 18 88-22 | Pin Groove |
| 4 | 812 00 00-02 | E Ring #5133-62 |
| 5 | 819 21 16-21 | Washer 21/32 x 1 x 21 Ga. |
| 6 | 532 12 01-83 | Bearing Nylon |
| 7 | 532 12 56-31 | Grip Handle Fluted |
| 8 | 532 12 23-65 | Button Plunger Red |
| 11 | 532 16 58-29 | Link Asm Lift LH |
| 12 | 532 16 58-31 | Link Asm Lift RH |
| 13 | 532 12 46-70 | Retainer Spring |
| 15 | 532 17 32-88 | Link Front |
| 16 | 873 35 08-00 | Nut Jam Hex 1/2-13 unc |
| 17 | 532 17 56-89 | Trunnion Blk Zinc |
| 18 | 873 80 08-00 | Nut Lock w/Wsh 1/2-13 unc |
| 19 | 532 13 98-68 | Arm Suspension Mower |
| 20 | 532 19 42-09 | Pin Cotter 7/16 Bowtie Lock |
| 23 | 532 11 08-07 | Nut Special |
| 24 | 819 13 10-16 | Washer 13/32 x 5/8 x 16 Ga. |
| 25 | 532 16 40-24 | Spring |
| 26 | 532 16 94-84 | Retainer Clip |
| 27 | 532 16 45-43 | Rod Adj Lift |
| 28 | 873 35 06-00 | Nut Hex Jam 3/8-16 unc |
| 29 | 532 13 80-57 | Knob Inf 3/8-16 unc Blk w/Sym |
| 30 | 532 15 02-33 | Trunnion Infin Height |
| 31 | 532 16 98-65 | Bearing, Pvt. Lift. |
| 32 | 873 54 06-00 | Nut Crownlock 3/8-24 |
| 36 | 532 15 50-97 | Pointer Height Indicator |
| 37 | 532 12 39-35 | Plug Hole Blk 1.485/1.515 Dia |
| 38 | 817 06 05-16 | Screw 5/16-18 x 1 |
| 40 | 819 11 24-10 | Washer 11/32 x 1-1/2 x 10 Ga. |
| 41 | 532 12 39-34 | Scale Ind Height Blk |
| 49 | 532 14 52-12 | Nut Hex Flange Lock |
| 50 | 532 11 04-52 | Nut Push Phos & Oil |

NOTE: All component dimensions given in U.S. inches
1 inch = 25.4 mm

TRACTOR - - MODEL NO. CTH200 TWIN (96061022701), PRODUCT NO. 960 61 02-27
STEERING ASSEMBLY [41]

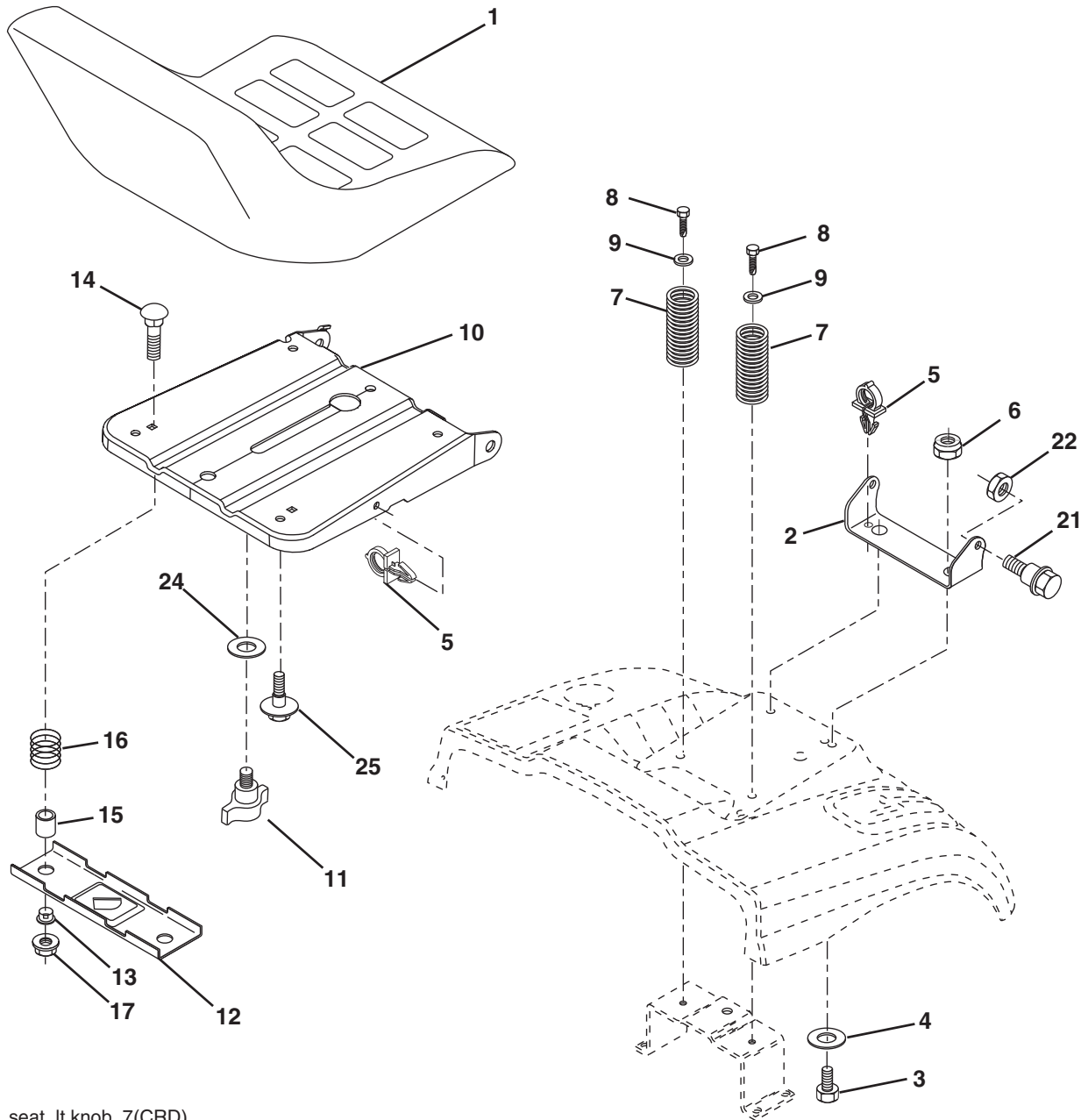

seat_lt.knob_7(CRD)

| KEY NO. | PART NO. | DESCRIPTION |
|---------|--------------|--------------------------------|
| 1 | 532 18 87-15 | Seat |
| 2 | 532 14 05-51 | Bracket Pnt Pivot Seat (blk) |
| 3 | 871 11 06-16 | Bolt Fin Hex 3/8-16 x 1 |
| 4 | 819 13 16-10 | Washer Flat 13/32 x 1 x 10 Ga. |
| 5 | 532 14 50-06 | Clip Push In Hinged |
| 6 | 873 80 06-00 | Nut Lock Hex w/Ins 3/8-16 |
| 7 | 532 12 41-81 | Spring Seat Cprsn 2 250 Blk Zi |
| 8 | 817 00 06-16 | Screw 3/8-16 x 1.5 |
| 9 | 819 13 16-14 | Washer 13/32 x 1 x 14 Ga |
| 10 | 532 19 55-30 | Pan Pnt Seat |
| 11 | 532 16 63-69 | Knob Seat Adj. Wingnut |
| 12 | 532 17 46-48 | Bracket Pnt Mounting Switch |

| KEY NO. | PART NO. | DESCRIPTION |
|---------|--------------|---------------------------------|
| 13 | 532 12 12-48 | Bushing Snap Blk Nyl 50 Id |
| 14 | 872 05 04-12 | Bolt Rdhd Sht Nk 1/4-20 x 1-1/2 |
| 15 | 532 12 12-49 | Spacer Split |
| 16 | 532 12 37-40 | Spring Cprsn |
| 17 | 532 12 39-76 | Nut Lock 1/4 Lge Flg Gr. 5 Zinc |
| 21 | 532 17 18-52 | Bolt Shoulder 5/16-18 unc-2A |
| 22 | 873 80 05-00 | Nut Hex Lock w/Ins 5/16-18 |
| 24 | 819 17 19-12 | Washer 17/32 x 1-3/16 x 12 Ga. |
| 25 | 532 12 70-18 | Bolt Shoulder 5/16-18 x 62 |

NOTE: All component dimensions given in U.S. inches.
 1 inch = 25.4 mm

**TRACTOR - - MODEL NO. CTH200 TWIN (96061022701), PRODUCT NO. 960 61 02-27
BAGGER 46**

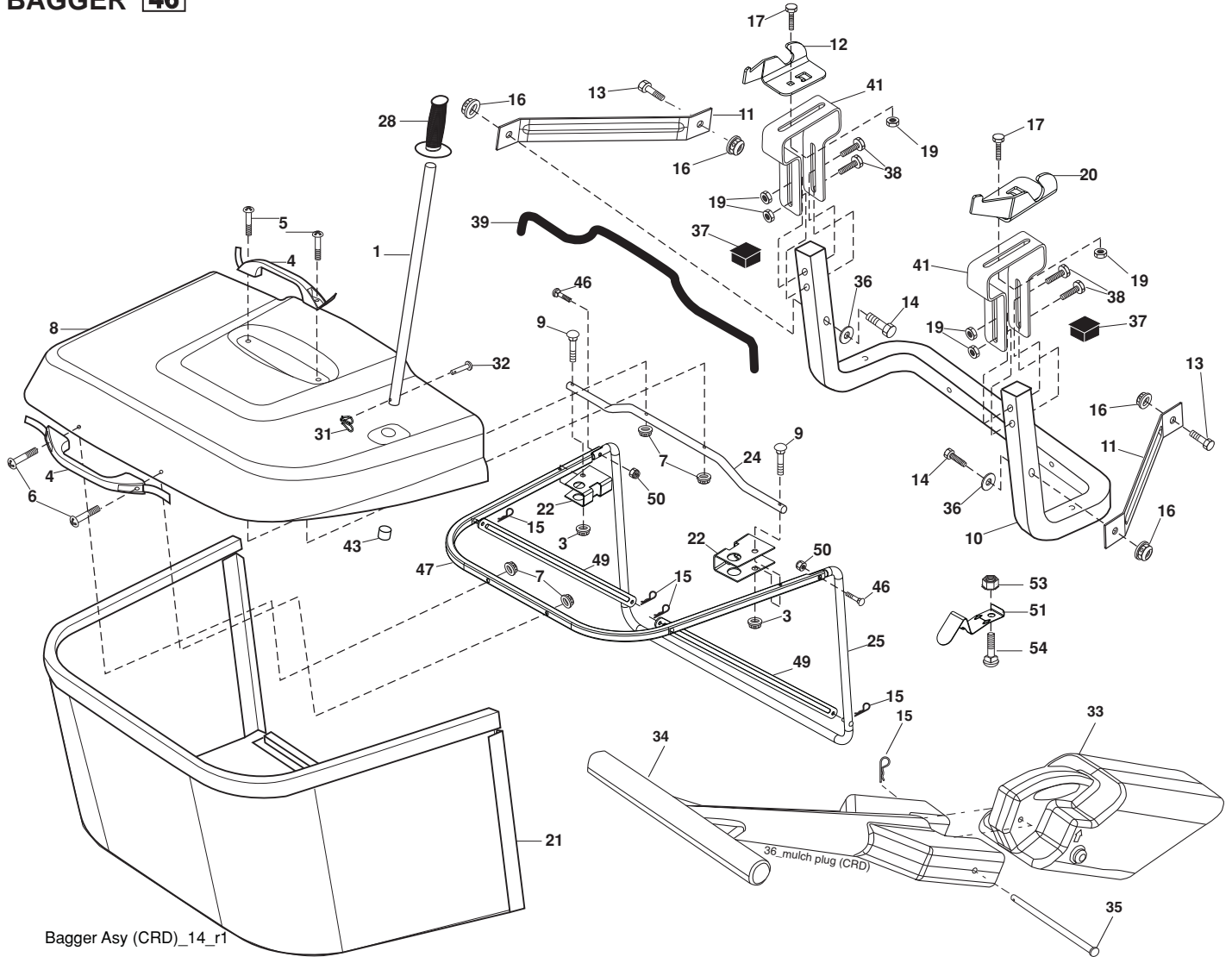

Bagger Asy (CRD)_14_r1

| KEY NO. | PART NO. | DESCRIPTION | KEY NO. | PART NO. | DESCRIPTION |
|---------|--------------|---------------------------------------|---------|--------------|--------------------------------|
| 1 | 532 16 52-49 | Tube Handle Bagger CRD | 28 | 532 16 57-87 | Grip Handle |
| 3 | 532 12 39-76 | Nut Lock 1/4 Lge Flg Gr. 5 Zinc | 31 | 532 16 94-84 | Retainer Clip |
| 4 | 532 16 99-16 | Handle Bagger w/Lvrs Blk CRD | 32 | 532 12 68-75 | Rivet Rd Hd Drilled 3/8 Dia |
| 5 | 874 98 10-24 | Screw Pan Head #10-24 x 1.50 Blk | 33 | 532 16 93-80 | Plug Mulcher |
| 6 | 874 98 10-32 | Screw Pan Hd | 34 | 532 16 55-70 | Handle Mulcher |
| 7 | 873 40 10-00 | Nut Wiz Lock Hex Serr/Hd 10-24 | 35 | 532 16 55-72 | Pin Mulcher |
| 8 | 532 18 10-95 | Cover Bagger | 36 | 819 13 20-12 | Washer 13/32 x 1-1/4 x 12 Ga. |
| 9 | 872 14 04-18 | Bolt Carriage 1/4-20 x 2.25d x Gr. 5 | 37 | 532 17 54-01 | Plug Support Bagger CRD |
| 10 | 532 18 12-82 | Tube Support Bagger CRD | 38 | 872 01 05-20 | Bolt 5/16-18 x 2-1/2 |
| 11 | 532 16 57-19 | Bracket Support Upper Bag CRD | 39 | 532 41 62-57 | Seal |
| 12 | 532 18 88-48 | Bracket Pivot LH | 41 | 532 16 96-83 | Bracket Pnt Adj Pvt Bagger CRD |
| 13 | 874 76 06-12 | Bolt 3/8-16 unc x 3/4 | 43 | 532 17 40-83 | Plug Tubing End |
| 14 | 874 52 06-36 | Bolt Fin Hex 3/8-16 x 2-1/4 Gr. 5 | 46 | 872 11 05-10 | Bolt 5/16-18 x 1-1/4 |
| 15 | 532 12 46-70 | Retainer Spring | 47 | 532 19 37-04 | Tube Upper Bagger |
| 16 | 873 90 06-00 | Nut Lock 3/8-16 unc | 49 | 532 19 33-05 | Bar Spreader |
| 17 | 872 14 05-06 | Bolt Rdhd Sht Sqnk 5/16 -18 unc x 3/4 | 50 | 873 80 05-00 | Nut 5/16-18 |
| 19 | 873 90 05-00 | Nut Lock Hex Flange 5/16-18 | 51 | 532 19 99-03 | Latch Spring Bagger |
| 20 | 532 18 88-47 | Bracket Pivot RH | 53 | 873 51 04-00 | Nut 1/4-20 unc |
| 21 | 532 40 61-80 | Bag Asm CRD | 54 | 872 14 04-06 | Bolt 1/4-20 x 3/4 Gr. 5 |
| 22 | 532 16 57-81 | Bracket Side Bagger CRD | | | |
| 24 | 532 16 57-83 | Tube Pivot Bagger CRD | | | |
| 25 | 532 19 37-05 | Tube Front Bagger | | | |

NOTE: All component dimensions given in U.S. inches
1 inch = 25.4 mm

