

YTH2546 TD

Spare parts

Ersatzteile

Pièces détachées

Reserve onderdelen

Repuestos

Reservdelar

TRACTOR -- MODEL NO. YTH2546TD (96041005502), PRODUCT NO. 960 41 00-55
DECALS 27

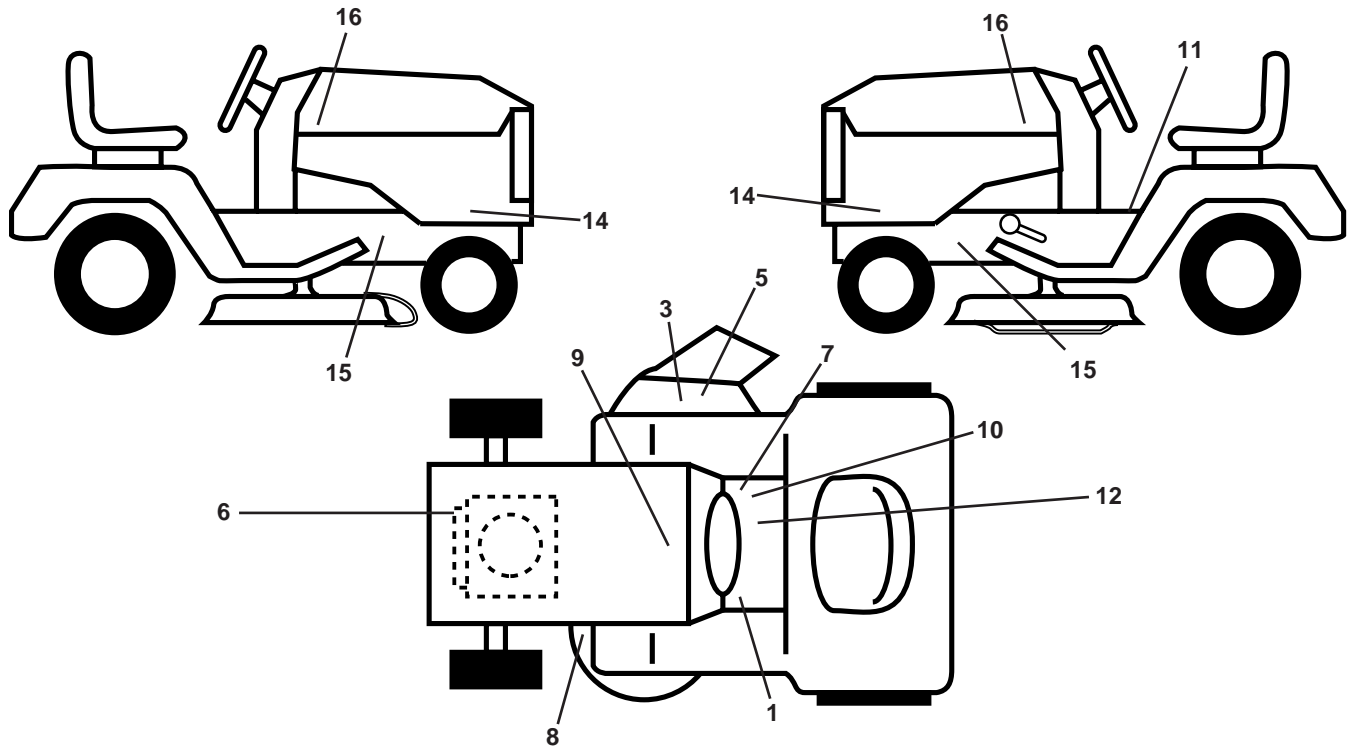

KEY PART NO. NO.

DESCRIPTION

1	532 15 97-37	Decal, Brake/Clutch Sym
3	532 19 63-57	Decal, Warning Deflect. Cutfinger
5	532 18 21-66	Decal, Cutfinger CE
6	532 19 68-41	Decal, Warning Eng. Syms.
7	532 14 08-37	Decal, Saddle Brake Parking
8	532 16 03-96	Decal, Mower Sch. V-Belt
9	532 14 50-05	Decal, Battery Dan./Poi.
10	532 17 83-02	Decal, Oper. Cruise Sym.

KEY PART NO. NO.

DESCRIPTION

11	532 40 03-89	Decal, Warning Sym. CE
14	532 42 39-86	Decal, Panel Side
15	532 15 97-36	Decal, Chassis Hot Muffler
16	532 42 20-12	Decal, Hood Logo
--	532 16 69-60	Decal, Bypass
--	532 40 17-71	Pad, Footrest, LH
--	532 40 37-73	Pad, Footrest, RH
--	532 16 25-98	Decal, Drawbar Load
--	532 42 30-37	Manual, Operator's

WHEELS AND TIRES

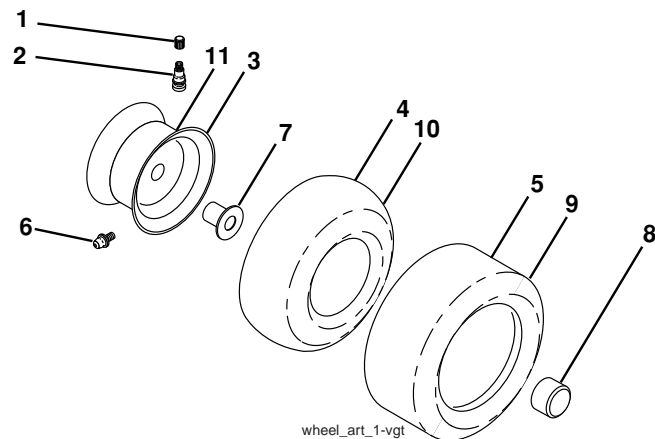

KEY PART NO. NO.

DESCRIPTION

1	532 05 91-92	Cap, Valve, Tire
2	532 06 51-39	Stem, Valve
3	532 13 83-36	Rim Assembly, Front
4	532 05 99-04	Tube, Front (Service Item Only)
5	532 10 62-22	Tire, Front
6	532 12 49-57	Fitting, Grease (Front Wheel Only)
7	532 12 49-59	Bearing, Flange (Front Wheel Only)
8	532 17 50-39	Cap, Axle (Front Wheel Only)
9	532 12 20-82	Tire, Rear
10	532 12 49-26	Tube, Rear (Service Item Only)
11	532 13 83-37	Rim Assembly, Rear
--	532 14 43-34	Sealant, Tire (10 oz. Tube)

NOTE: All component dimensions given in U.S. inches
 1 inch = 25.4 mm

TRACTOR - - MODEL NO. YTH2546TD (96041005502), PRODUCT NO. 960 41 00-55

SCHEMATIC **38**

SCH13

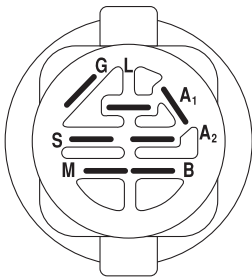
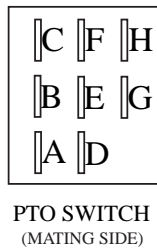
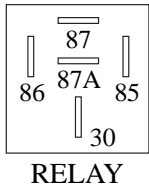
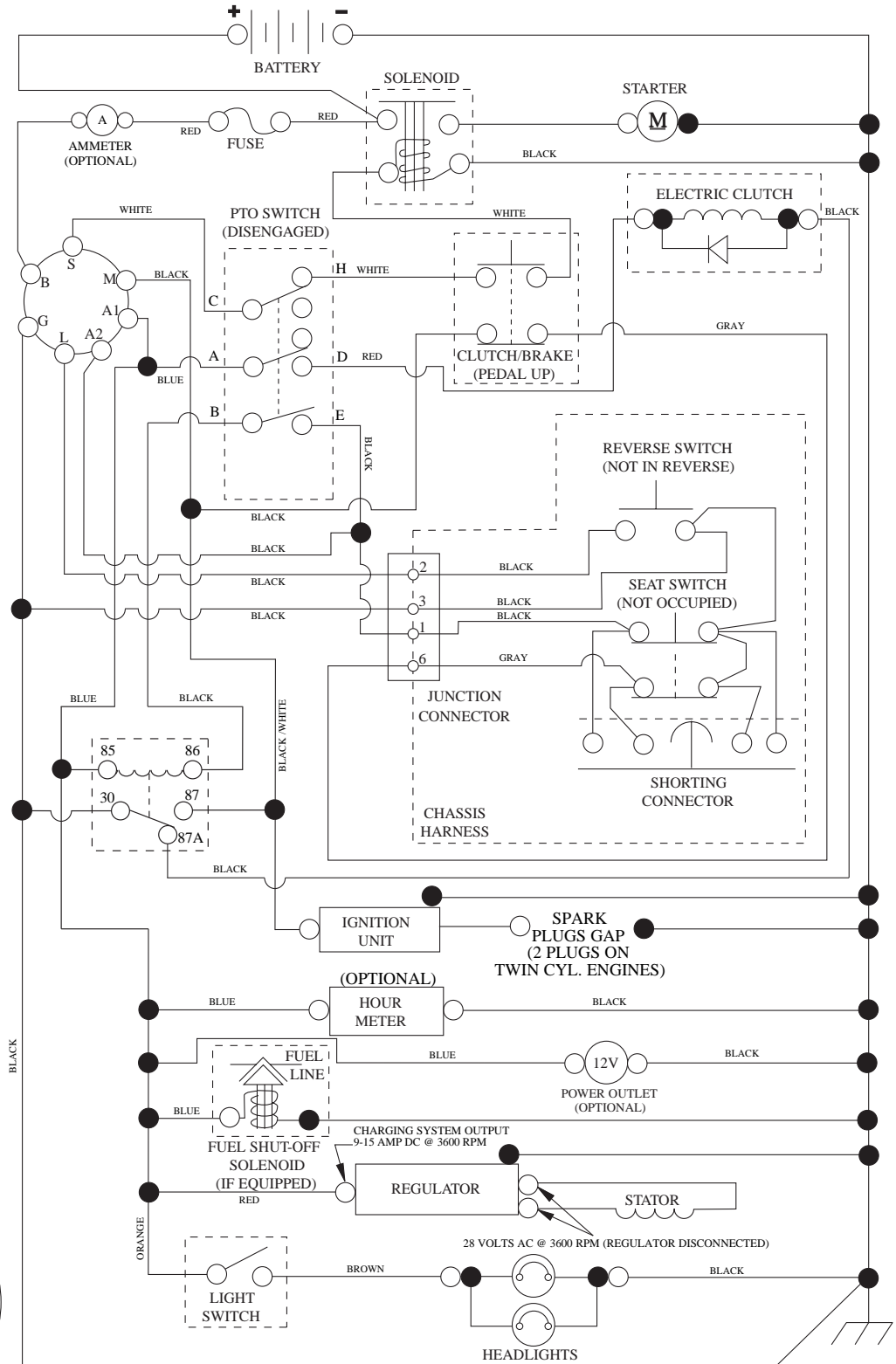

POSITION	CIRCUIT	"MAKE"
OFF	M+G+A1	
RUN/OVERRIDE	B+A1	
RUN	B+A1	L+A2
START	B + S + A1	

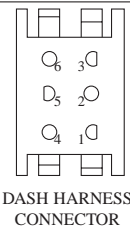

WIRING INSULATED CLIPS
NOTE: IF WIRING INSULATED CLIPS WERE REMOVED FOR SERVICING OF UNIT, THEY SHOULD BE RE-INSTALLED TO PROPERLY SECURE YOUR WIRING.

NON-REMOVABLE CONNECTIONS

REMOVABLE CONNECTIONS

TRACTOR -- MODEL NO. YTH2546TD (96041005502), PRODUCT NO. 960 41 00-55
ELECTRICAL 32

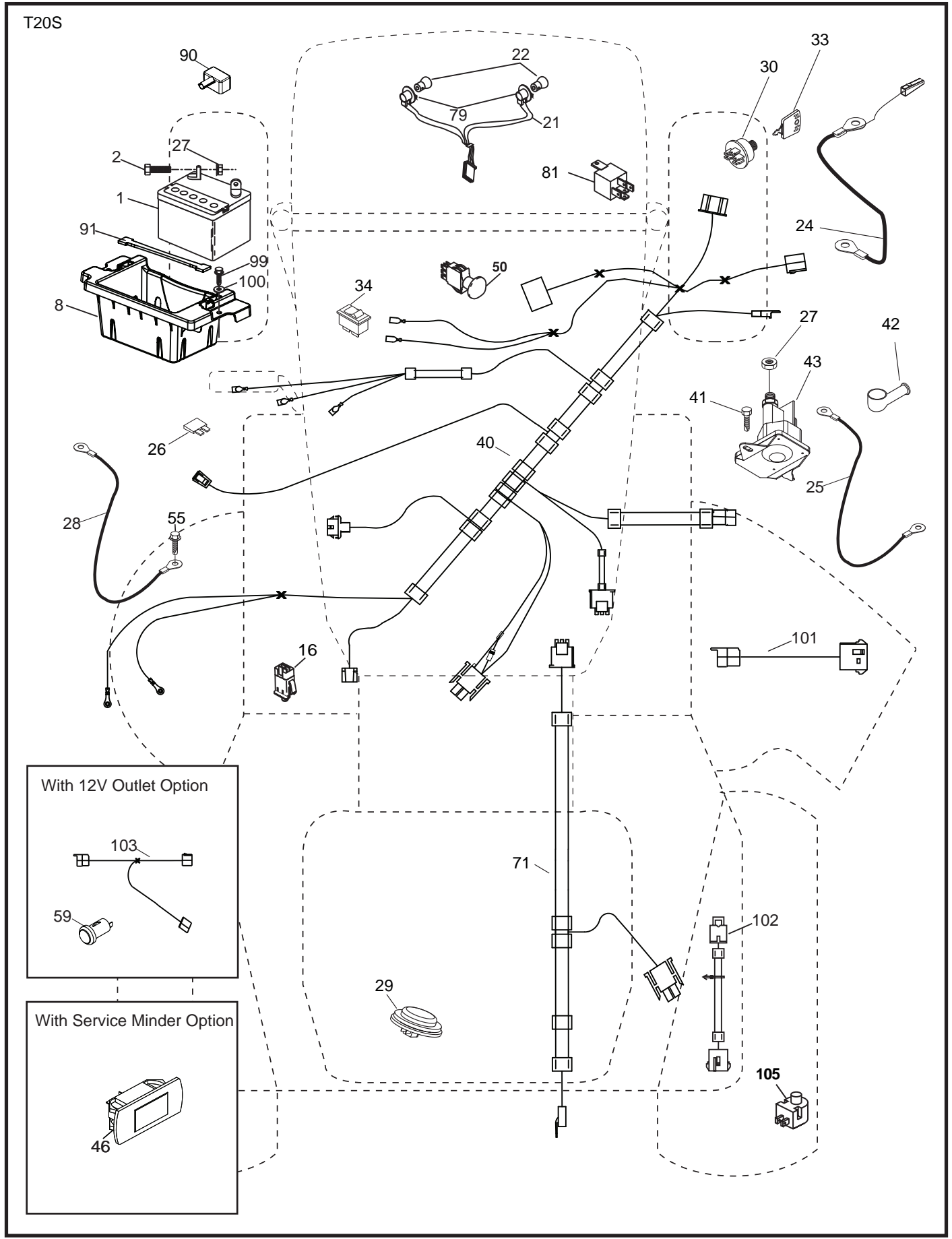

**TRACTOR - - MODEL NO. YTH2546TD (96041005502), PRODUCT NO. 960 41 00-55
ELECTRICAL 32**

KEY NO.	PART NO.	DESCRIPTION
1	532 16 34-65	Battery
2	874 76 04-12	Bolt Hex Hd. 1/4-20 unc x 3/4
8	532 18 64-91	Battery Box
16	532 17 61-38	Switch Interlock
21	532 18 37-59	Harness Socket Light
22	532 00 41-52	Bulb, Light # 1156
24	532 40 02-53	Cable Battery
25	532 41 28-95	Cable Starter
26	532 17 51-58	Fuse
27	873 51 04-00	Nut Keps Hex 1/4-20 unc
28	532 14 54-91	Cable Ground 21" Blk. 6 Ga.
29	532 40 15-45	Switch Seat
30	532 19 33-50	Switch Ign.
33	532 41 19-33	Key/Chain
34	532 11 07-12	Switch Light/Reset
40	532 40 96-14	Harness Ignition Dash
41	817 72 04-08	Screw Thd. Cut 1/4-20 x 1/2
42	532 13 15-63	Cover Terminal Red
43	532 19 25-07	Solenoid
46	532 41 39-31	Gauge Hourmeter
50	532 17 46-51	Switch PTO
55	817 06 05-12	Screw Thdrol. 5/16-18 x 3/4
59	532 40 03-03	Outlet 12-Volt
71	532 19 42-76	Harness Chassis
79	532 17 52-42	Socket Asm. Bulb
81	532 40 96-15	Relay Harness Sealed
90	532 40 07-24	Cover Terminal Battery
91	532 19 02-70	Strap Battery
99	817 67 04-12	Screw Hex Wsh. Thdrol. 1/4-20 x 3/4
100	819 09 14-16	Washer 9/32 x 7/8 x 16 Ga.
101	532 19 83-17	Pigtail Harness Clutch
102	532 40 44-54	Harness Pigtail
103	532 40 79-62	Harness Pigtail 12V Outlet
105	532 40 75-68	Switch Reverse

NOTE: All component dimensions given in U.S. inches
1 inch = 25.4 mm

TRACTOR -- MODEL NO. YTH2546TD (96041005502), PRODUCT NO. 960 41 00-55
CHASSIS AND ENCLOSURES **39**

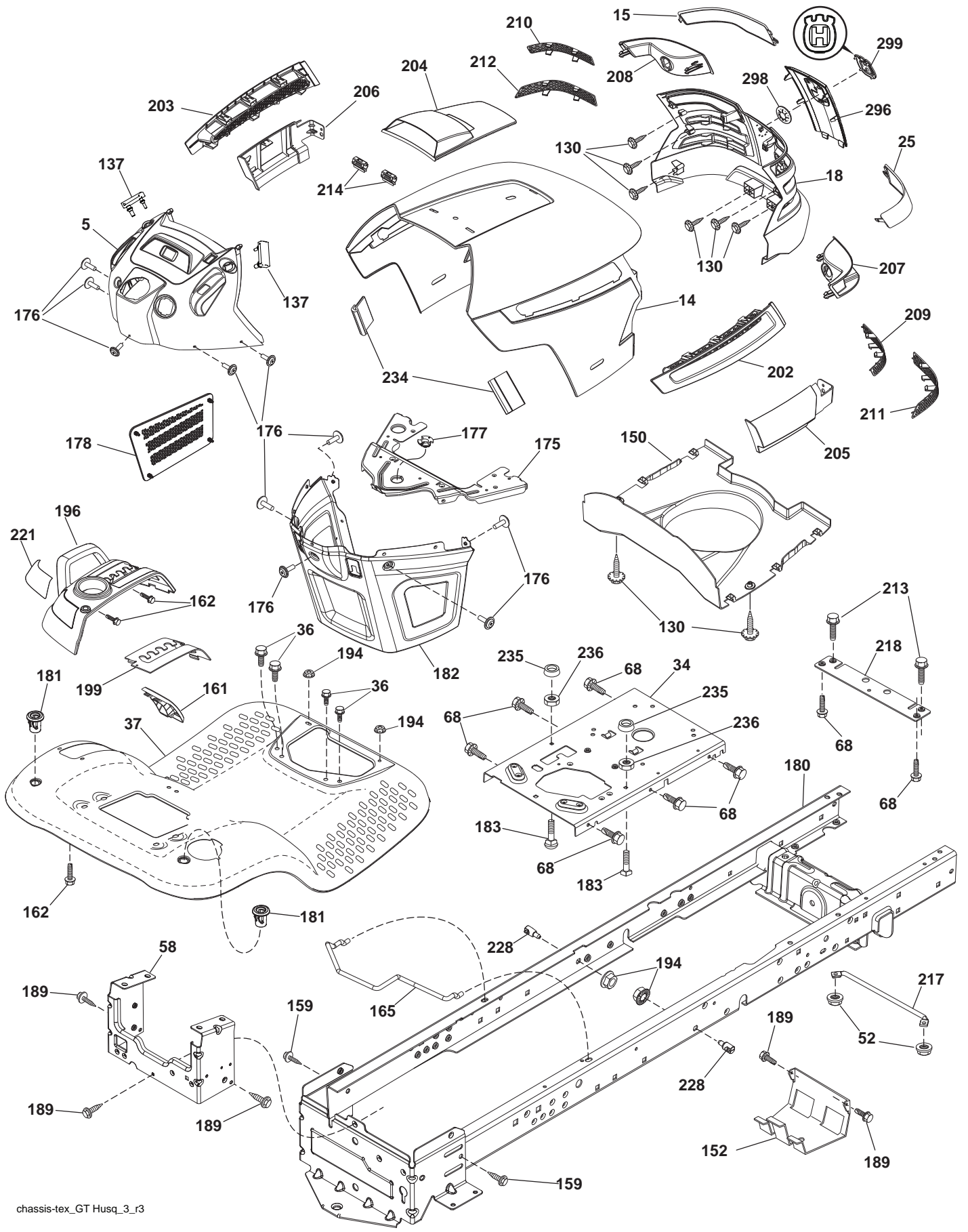

chassis-tex_GT Husq_3_r3

**TRACTOR -- MODEL NO. YTH2546TD (96041005502), PRODUCT NO. 960 41 00-55
CHASSIS AND ENCLOSURES 39**

KEY PART NO. NO.	DESCRIPTION	KEY PART NO. NO.	DESCRIPTION	
3	532 40 50-12	202	532 40 30-48	Vent Side Hood RH
5	532 40 87-03	203	532 40 30-76	Vent Side Hood LH
14	532 41 10-46	204	532 41 66-13	Vent Top Hood
15	532 19 89-09	205	532 40 17-09	Skirt Hood Side RH
18	532 40 86-07	206	532 40 17-11	Skirt Hood Side LH
25	532 19 89-08	207	532 19 71-98	Bezel RH
34	532 19 61-25	208	532 19 71-99	Bezel LH
36	817 06 05-12	209	532 19 91-30	Insert Hex Top RH
37	532 40 18-25	210	532 19 91-31	Insert Hex Top LH
52	873 68 05-00	211	532 19 91-32	Insert Hex Bottom RH
58	532 41 22-81	212	532 19 91-33	Insert Hex Bottom LH
68	817 49 05-08	213	874 76 05-12	Bolt 5/16-18 unc x 3/4
130	532 41 63-58	214	532 19 91-45	Clip Retainer Tinner
137	532 40 75-90	217	532 40 91-67	Rod Pivot
150	532 19 85-12	218	532 19 63-95	X-Piece Hood Stop
152	532 19 95-35	221	532 19 89-09	Reflector LH
159	817 00 06-12	228	532 19 51-61	Stud Fastner
161	532 40 18-26	230	532 17 01-65	Bolt Shoulder 5/16-18
162	532 14 24-32	234	532 40 47-42	Bumper Hood
165	532 19 68-26	235	532 40 61-29	Spacer Fender
175	532 19 63-04	236	873 93 05-00	Nut Lock 5/16-18 unc
176	532 40 07-76	238	532 40 86-06	Trim
177	532 19 52-27	239	532 11 04-52	Nut Push
178	532 19 97-82			
180	532 41 50-64			
181	532 40 30-25			
182	532 40 68-59			
183	874 78 05-20			
189	817 00 05-12			
194	873 90 05-00			
196	532 40 02-99			
199	532 19 82-59			

NOTE: All component dimensions given in U.S. inches
1 inch = 25.4 mm

TRACTOR -- MODEL NO. YTH2546TD (96041005502), PRODUCT NO. 960 41 00-55
DRIVE **40**

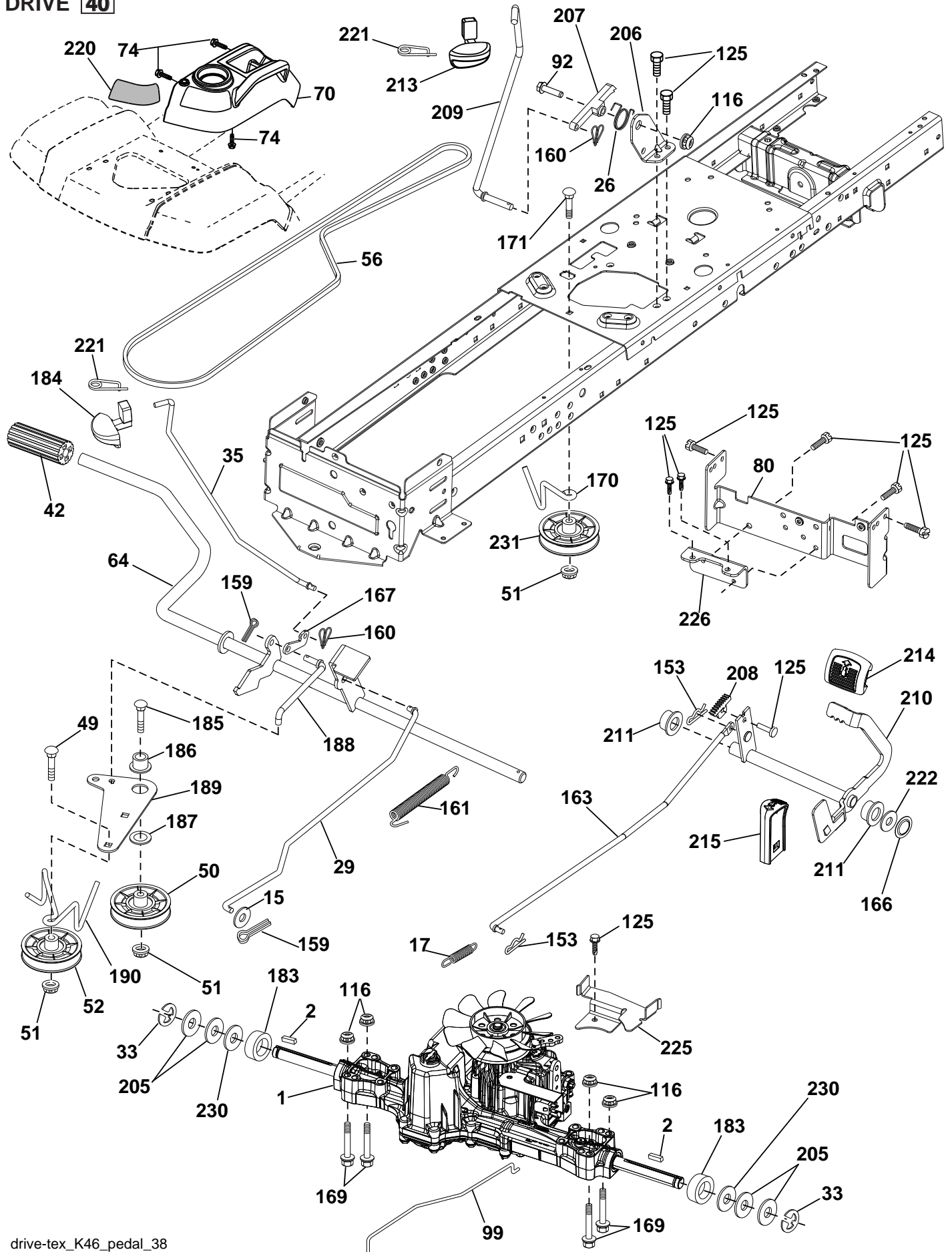

**TRACTOR -- MODEL NO. YTH2546TD (96041005502), PRODUCT NO. 960 41 00-55
DRIVE 40**

KEY PART NO. NO.	DESCRIPTION	KEY PART NO. NO.	DESCRIPTION
1	-----	171	872 11 06-16 Bolt Rdhd. Sqnk. 3/8-16 unc x 2
2	532 12 35-83	183	532 13 70-57 Spacer Split
15	819 13 13-16	184	532 40 31-18 Handle Parking Brake
17	532 41 36-78	185	872 11 06-22 Bolt Rdhd. Sqnk. 3/8-16 x 2-3/4
26	532 19 96-79	186	532 19 43-21 Spacer Retainer
29	532 40 38-06	187	819 13 32-10 Washer
33	812 00 00-01	188	532 19 43-23 Link Clutch Ground Drive
35	532 19 95-91	189	532 19 43-17 Bellcrank Ground Drive
42	532 12 48-72	190	532 19 43-18 Keeper Bellcrank Ground Drive
49	872 11 06-14	196	817 00 06-16 Screw 3/8-16 x 1
50	532 19 43-27	197	532 19 58-04 Link Clutch Anti-Rotation
51	873 90 06-00	205	532 12 17-48 Washer
52	532 19 43-26	206	532 19 78-67 Bracket Mount Latch Cruise
56	532 13 09-69	207	532 19 78-68 Latch Control Cruise
64	532 19 78-65	208	532 19 78-69 Gear Sector Control Cruise
70	532 40 05-30	209	532 19 95-92 Rod Control Cruise
74	532 14 24-32	210	532 19 78-60 Rocker Asm. Pedal Control
80	532 41 00-24	211	532 12 01-83 Bearing Nylon
92	874 76 05-20	213	532 40 31-19 Knob Control Cruise
99	532 41 57-42	214	532 40 17-22 Pedal Forward
116	873 90 05-00	215	532 40 17-23 Pedal Reverse
125	817 00 05-12	216	532 19 61-31 Bracket Pulley Idler
143	817 49 05-08	220	532 19 89-08 Reflector RH
153	532 12 47-88	221	532 40 31-87 Retainer Spring Clip Handle
159	876 02 04-12	222	879 21 20-10 Washer 21/32 x 1-1/4 x 10 Ga.
160	532 16 94-84	225	532 40 33-19 Keeper Belt Trans.
161	532 10 57-09	226	532 40 15-64 Bracket Mount Torque
163	532 40 10-34	230	532 18 89-67 Washer Hardened
166	532 19 72-90		
167	532 40 52-57		
169	874 49 05-44		
170	532 19 43-22		

NOTE: All component dimensions given in U.S. inches
1 inch = 25.4 mm

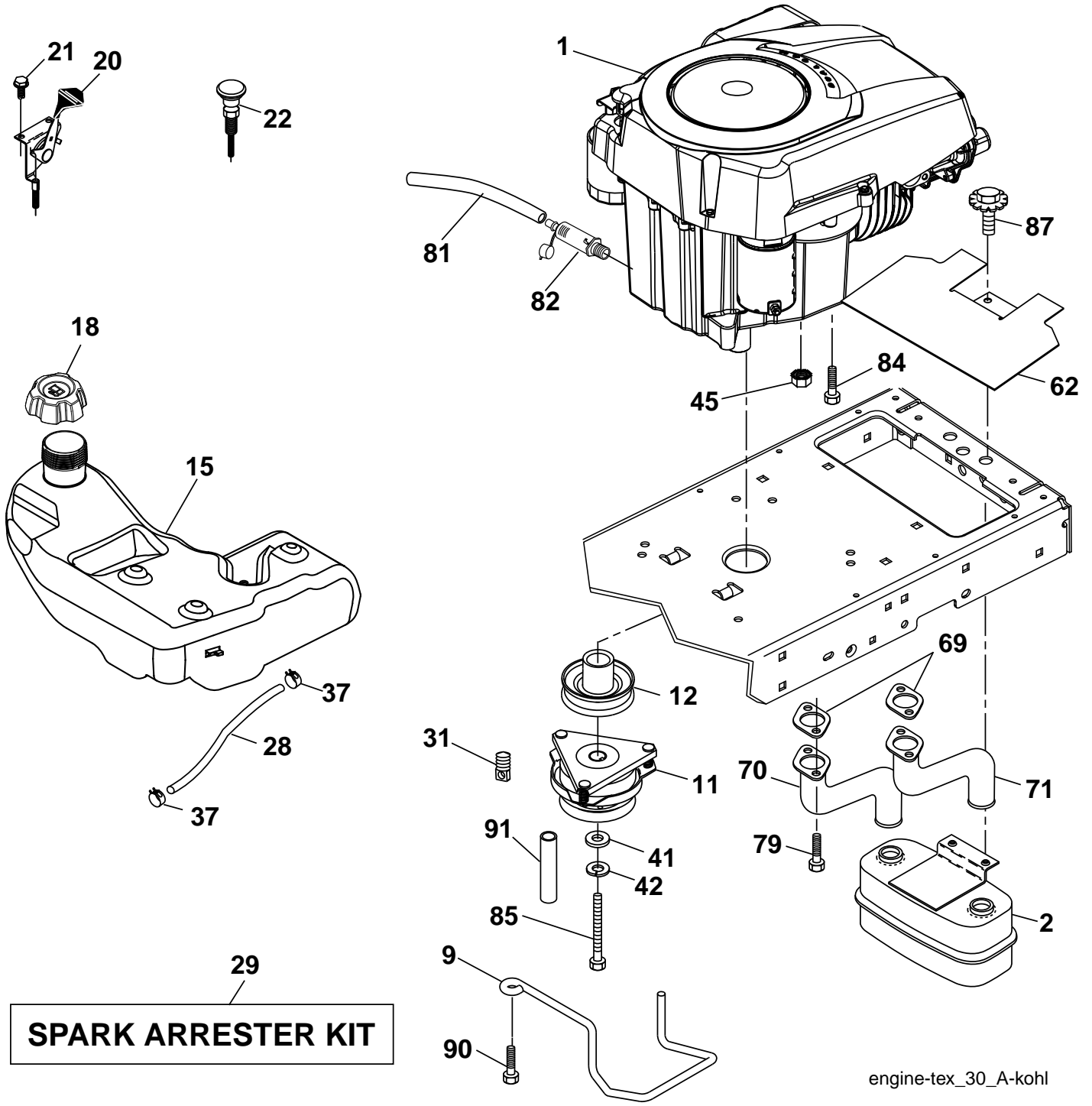

**TRACTOR -- MODEL NO. YTH2546TD (96041005502), PRODUCT NO. 960 41 00-55
ENGINE 24**

KEY PART NO. NO.	DESCRIPTION
1 --- -- ----	Engine KOHL Model No. SV730-0022
2 532 14 97-23	Muffler
9 532 19 43-20	Keeper Belt Engine
11 532 40 00-08	Clutch Electric
12 532 40 50-97	Pulley Engine
15 532 19 34-99	Tank Fuel 4.0
18 532 19 42-67	Cap Asm.
20 532 18 29-37	Control Throttle
21 532 41 63-58	Screw #10 x 0.750 BOS Thread
22 532 19 15-96	Control Choke
28 532 14 21-58	Fuel Line
29 532 13 71-80	Spark Arrester Kit
31 532 14 50-06	Clip Push-In
37 532 12 34-87	Clamp Hose
41 532 12 61-97	Washer 1-1/2 OD x 15/32 ID x .250
42 810 04 07-00	Washer Lock 7/16
45 873 51 04-00	Nut Keps Hex 1/4-20 unc
62 532 14 66-29	Shield Heat Muffler
69 --- -- ----	Gasket
70 532 14 66-99	Tube Exhaust LH
71 532 14 67-00	Tube Exhaust RH
79 532 19 23-34	Screw Socket Head 5/16-18 x .75
81 532 14 84-56	Tube Drain Oil Easy
82 532 18 16-54	Plug Drain Oil
84 817 12 06-16	Screw 3/8-16 x 1
85 532 17 39-37	Bolt Hex 7/16-20 x 4-5 Ga.
87 532 17 18-77	Bolt 5/16-18 unc x 1 w/Sems.
90 817 00 06-16	Screw 3/8-16 x 1
91 532 18 74-95	Bushing

NOTE: All component dimensions given in U.S. inches.
1 inch = 25.4 mm

TRACTOR -- MODEL NO. YTH2546TD (96041005502), PRODUCT NO. 960 41 00-55
STEERING ASSEMBLY **41**

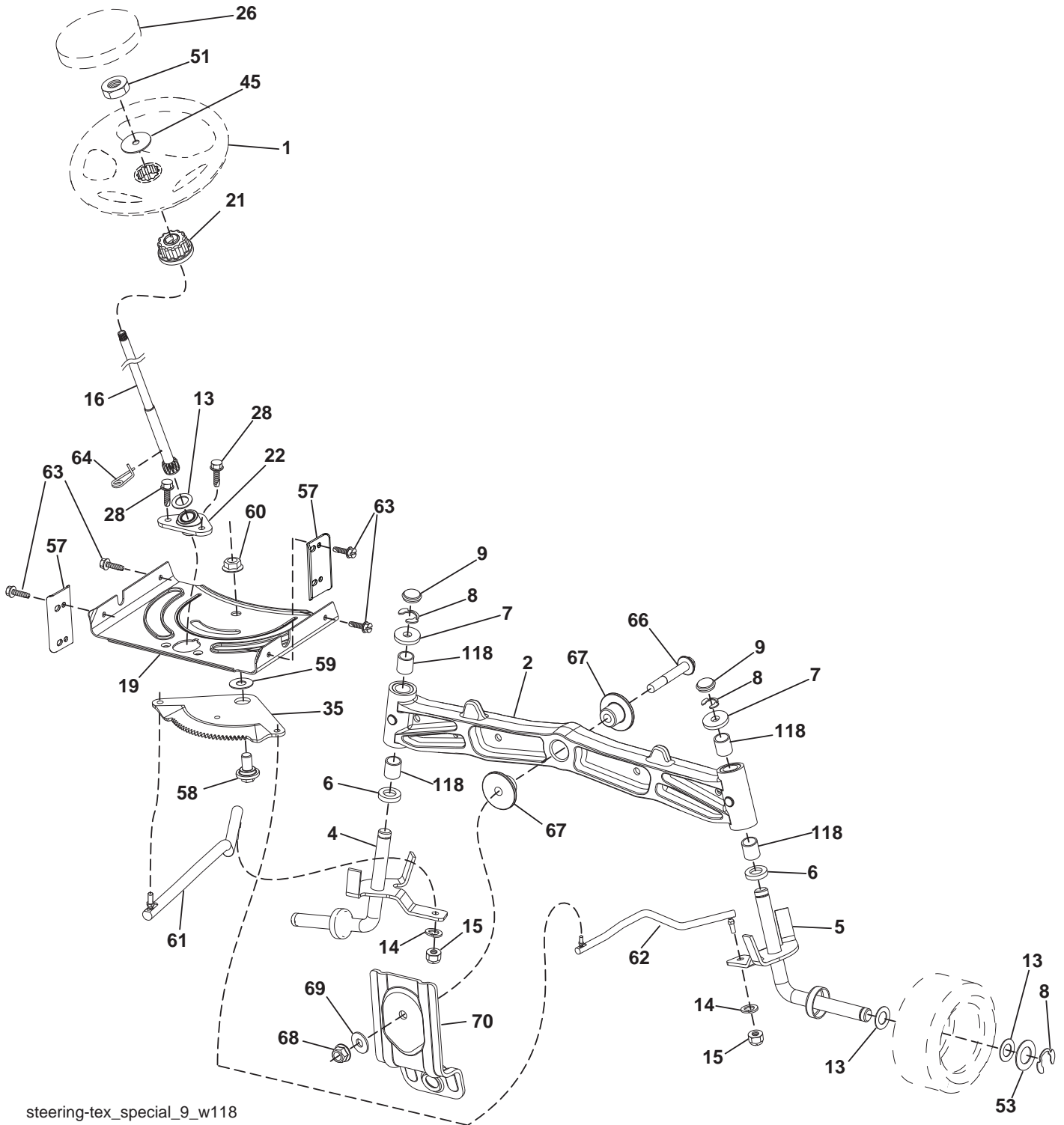

steering-tex_special_9_w118

**TRACTOR - - MODEL NO. YTH2546TD (96041005502), PRODUCT NO. 960 41 00-55
STEERING ASSEMBLY **41****

KEY NO.	PART NO.	DESCRIPTION
1	532 41 64-80	Wheel, Steering Husq SR
2	532 41 35-91	Axle Asm., Front
4	532 40 30-87	Spindle Asm., LH
5	532 40 30-88	Spindle Asm., RH
6	532 12 49-31	Bearing, Race Thrust Harden
7	532 12 17-48	Washer 25/32 x 1-5/8 x 16 Ga.
8	812 00 00-29	Ring, Clip #T5304-75
9	532 12 12-32	Cap, Spindle
13	532 12 17-49	Washer 25/32 x 1-1/4 x 16 Ga.
14	810 04 06-00	Washer, Lock Hvy. Hlcl. Spr. 3/8
15	873 54 06-00	Nut, Crown Lock 3/8-24 unf
16	532 19 47-46	Shaft Steering
19	532 19 47-29	Plate Steering
21	532 18 67-37	Adapter, Wheel Steering
22	532 19 48-45	Bushing, Strg. Blk.
26	532 41 59-87	Insert, Wheel Steering Husq SR
28	817 00 06-12	Screw 3/8-16 x 3/4
35	532 19 47-32	Gear, Sector Plate
45	819 18 38-12	Washer 9/16 x 2-3/8 x 12 Ga.
51	873 94 08-00	Nut Hex Jam Toplock 1/2-20 unf
53	532 18 89-67	Washer Hardened .793 x 1.637 x .060
57	532 40 74-65	Bracket Upstop
58	532 19 47-47	Bolt Shoulder Sector Pivot CFM
59	532 19 47-48	Washer Thrust Sector Steering
60	873 97 10-00	Nut Flange Lock 5/8-11
61	532 19 47-40	Draglink, LH
62	532 19 47-41	Draglink, RH
63	817 00 05-12	Screw 5/16-18 x 3/4
64	532 19 98-49	Retainer Clip Spring Steering
66	871 02 07-48	Bolt Hex Fghd. 7/16-14 x 3 Serr.
67	532 19 47-37	Bushing PM Front Axle
68	873 90 07-00	Nut Lock Flange 7/16-14 Gr. 5
69	532 19 91-62	Washer 1.5 x .505 x .118
70	532 19 61-97	Bracket Deck Susp. Front
118	532 40 60-13	Bushing

NOTE: All component dimensions given in U.S. inches
1 inch = 25.4 mm

TRACTOR -- MODEL NO. YTH2546TD (96041005502), PRODUCT NO. 960 41 00-55
 MOWER DECK **44**

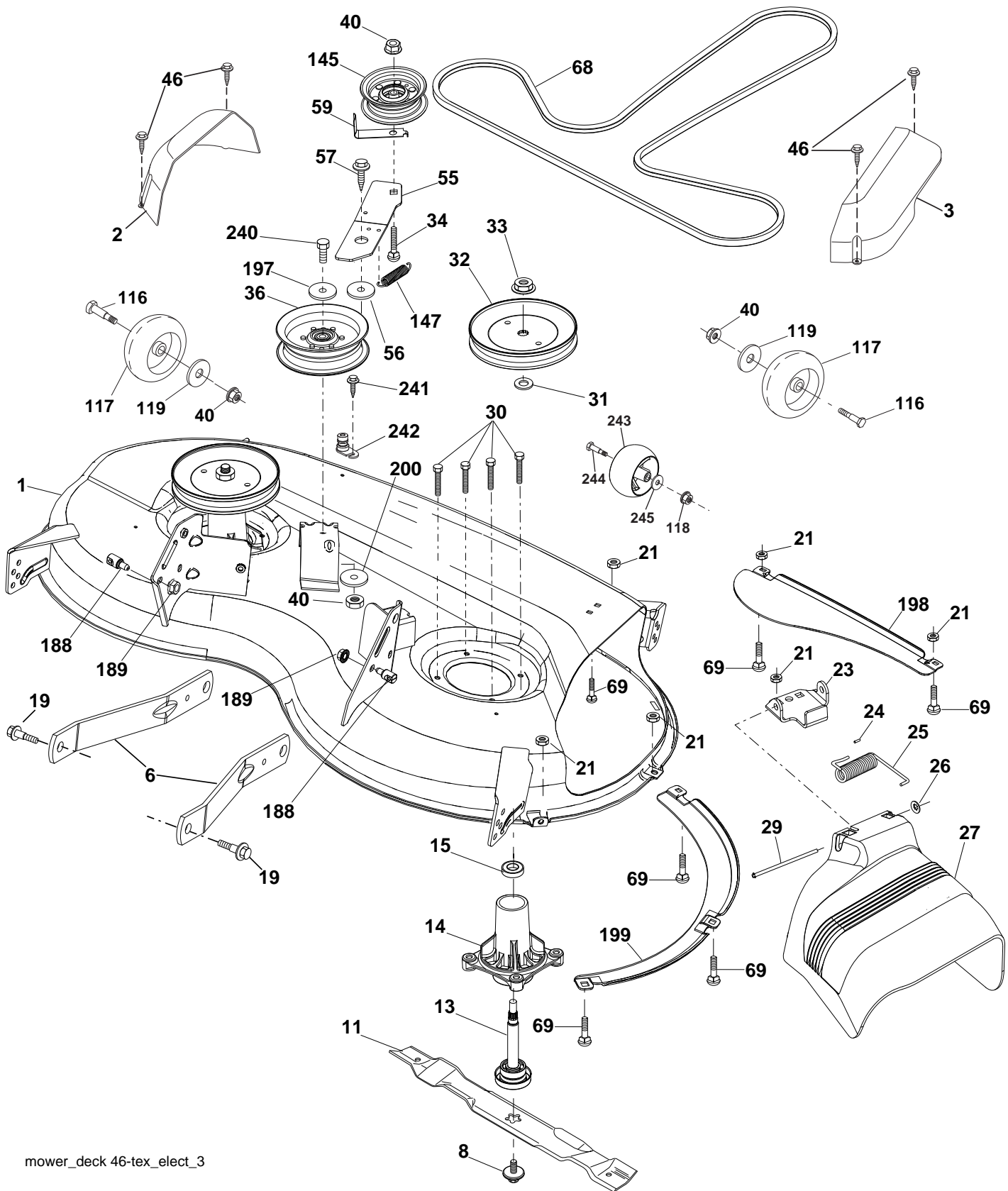

mower_deck 46-tex_elect_3

**TRACTOR -- MODEL NO. YTH2546TD (96041005502), PRODUCT NO. 960 41 00-55
MOWER DECK 44**

KEY NO.	PART NO.	DESCRIPTION	KEY NO.	PART NO.	DESCRIPTION
1	532 42 41-20	Mower Housing	69	872 14 05-05	Bolt
2	532 40 55-07	Cover Mandrel LH	116	532 19 34-06	Bolt, Shoulder
3	532 40 55-06	Cover Mandrel RH	117	532 17 48-73	Wheel, Gauge
6	532 19 51-86	Arm Suspension	118	873 93 06-00	Nut Centerlock 3/8-16 unc
8	532 19 30-03	Bolt/Washer Asm. 7/16-20 unf	119	819 13 20-12	Washer. 13/32 x 1-1/4 x 12 Ga.
11	532 40 53-80	Blade Mower	145	532 19 31-97	Pulley, Idler, Flat
13	532 19 28-72	Shaft Assembly, Mandrel	147	532 19 72-51	Spring
14	532 18 72-81	Housing, Mandrel	188	532 19 51-61	Stud Fastener
15	532 11 04-85	Bearing, Ball, Mandrel	189	873 90 05-00	Nut Lock Hex Flange
19	532 19 65-39	Bolt, Shoulder	197	819 13 13-12	Washer 13-32 x 13/16 x 12 Ga.
21	873 68 05-00	Nut	198	532 40 31-49	Baffle Center Front
23	532 19 25-57	Bracket, Deflector	199	532 40 31-50	Baffle Front RH
24	532 10 53-04	Cap, Sleeve	200	532 41 35-24	Washer 13/32 x 1 x 1/2
25	532 19 70-26	Spring, Torsion, Deflector	240	874 52 06-36	Bolt 3/8-16 x 2-1/4 Gr. 5
26	532 11 04-52	Nut, Push	241	532 15 29-27	Screw
27	532 40 53-57	Shield, Deflector	242	532 41 55-98	Washout Port
29	532 13 14-91	Rod, Hinge	243	532 18 86-06	Wheel Gauge
30	532 17 39-84	Screw Thdrol. Rolling Wsh. Hd.	244	532 00 48-98	Bolt Shoulder
31	532 18 76-90	Washer, Spacer	245	819 12 14-14	Washer 3/8 x 7/8 x 14 Ga.
32	532 19 74-73	Pulley, Mandrel	---	532 41 64-05	Coupling Quick Connect
33	532 40 02-34	Nut, Toplock, Flanged	---	532 19 28-70	Mandrel Assembly (Includes housing, shaft assembly, and bearing only - pulley/nut/washer and blade bolt/washers not included)
34	872 11 06-12	Bolt Carr. Sh. 3/8-16 x 1-1/2 Gr. 5			
36	532 19 73-79	Pulley Idler			
40	873 90 06-00	Nut 3/8-16 unc	---	532 42 17-97	Replacement Mower, Complete
46	532 13 77-29	Screw			
55	532 19 72-49	Arm, Idler			
56	532 19 90-92	Spacer, Retainer			
57	817 00 06-16	Screw Hex Wsh. Thd. 3/8-16 x 1			
59	532 14 10-43	Guard, Tuv. Idler (94)			
68	532 40 51-43	V-Belt			

NOTE: All component dimensions given in U.S. inches
1 inch = 25.4 mm

TRACTOR -- MODEL NO. YTH2546TD (96041005502), PRODUCT NO. 960 41 00-55
MOWER LIFT 45

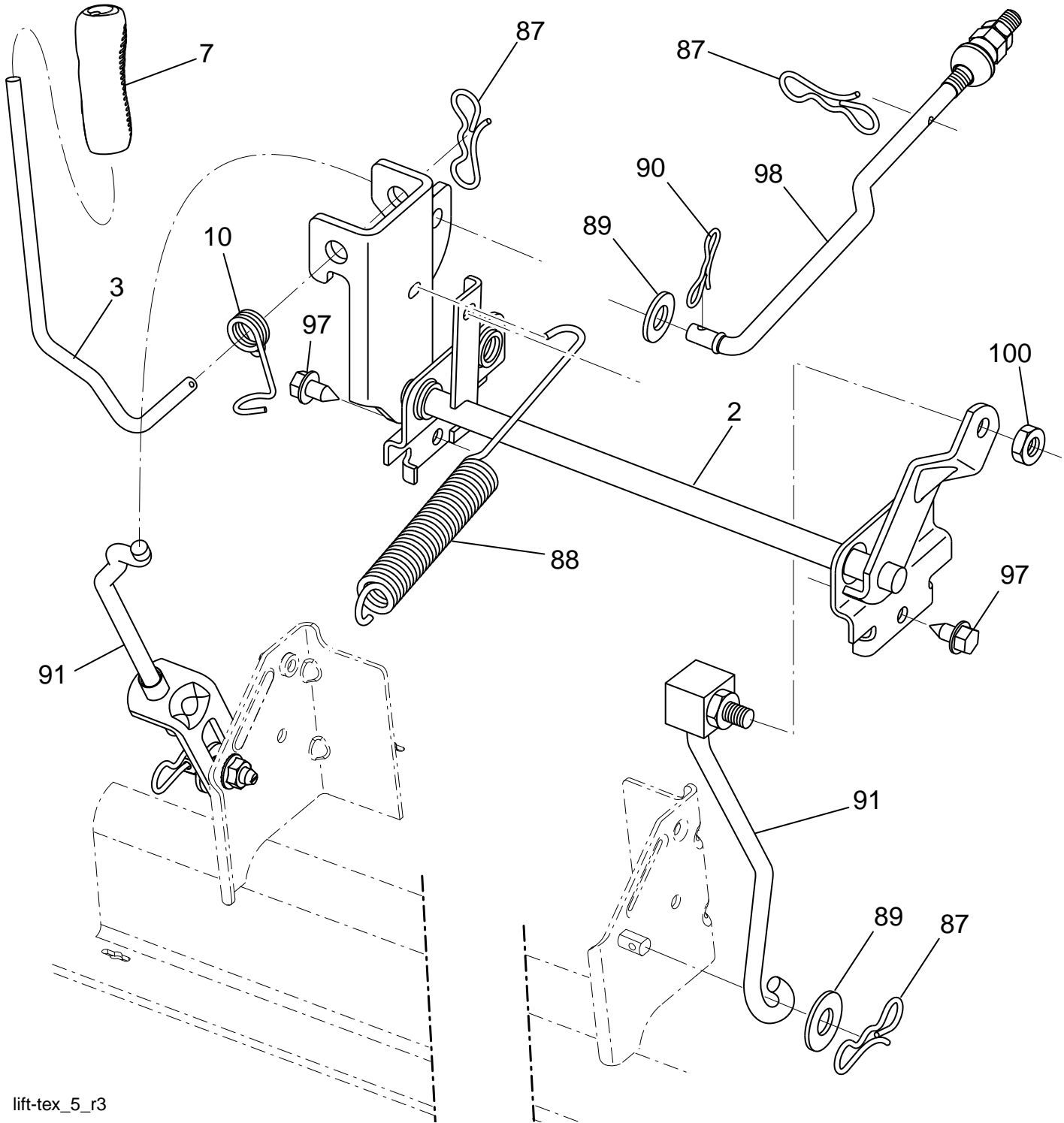

lift-tex_5_r3

KEY PART NO.	PART NO.	DESCRIPTION
2	532 19 52-23	Shaft Asm., Lift
3	532 19 52-30	Lever Asm., Lift
7	532 41 15-55	Grip, Lever
10	532 19 63-14	Spring Torsion
87	532 19 42-09	Pin Cotter 7/16 Bow Tie Lock
88	532 41 07-10	Spring Lift Assist
89	819 17 19-12	Washer Clear Zinc
90	532 19 42-08	Pin Cotter 5/16 Bow Tie Lock

KEY PART NO.	PART NO.	DESCRIPTION
91	532 19 51-81	Link Lift Susp. Mower Rear
97	817 00 06-12	Screw 3/8-16 x .75 Smgml. Tap/R.Z
98	532 19 52-70	Link Lift Susp. Front Mower
100	873 93 06-00	Nut Centerlock 3/8-16 unc

NOTE: All component dimensions given in U.S. inches
 1 inch = 25.4 mm

**TRACTOR -- MODEL NO. YTH2546TD (96041005502), PRODUCT NO. 960 41 00-55
SEAT ASSEMBLY 42**

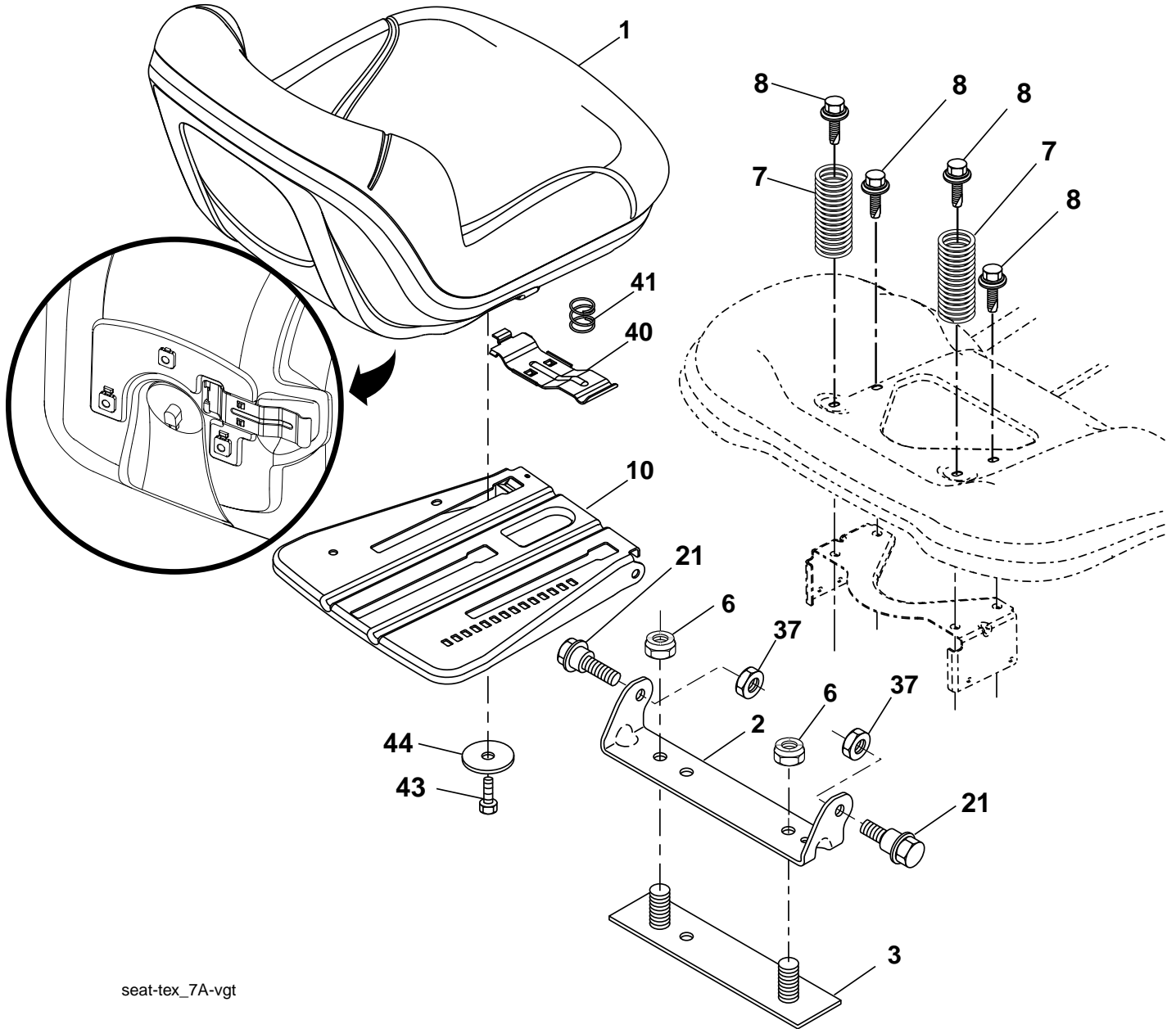

seat-tex_7A-vgt

KEY NO.	PART NO.	DESCRIPTION	KEY NO.	PART NO.	DESCRIPTION
1	532 40 66-21	Seat	37	873 80 05-00	Nut, Lock 5/16-18 unc
2	532 18 01-66	Bracket Pivot Fender	40	532 19 76-61	Handle Slide Seat
3	532 14 06-75	Strap, Asm. Fender	41	532 19 82-00	Spring Latch Seat
6	873 80 06-00	Nut, Lock w/Ins. 3/8-16 unc	43	874 76 06-12	Bolt 3/8-16 x 3/4
7	532 12 41-81	Spring, Seat Cprsn.	44	819 13 38-12	Washer 13/32 x 2-3/8 x 12 Ga.
8	532 17 18-77	Bolt 5/16-18 unc x 3/4 w/Sems.			
10	532 19 69-77	Pan, Seat			
21	532 17 18-52	Bolt, Shoulder 5/16-18			

NOTE: All component dimensions given in U.S. inches
1 inch = 25.4 mm

