

Ride Mower

YTH 20 K 46

96043003301

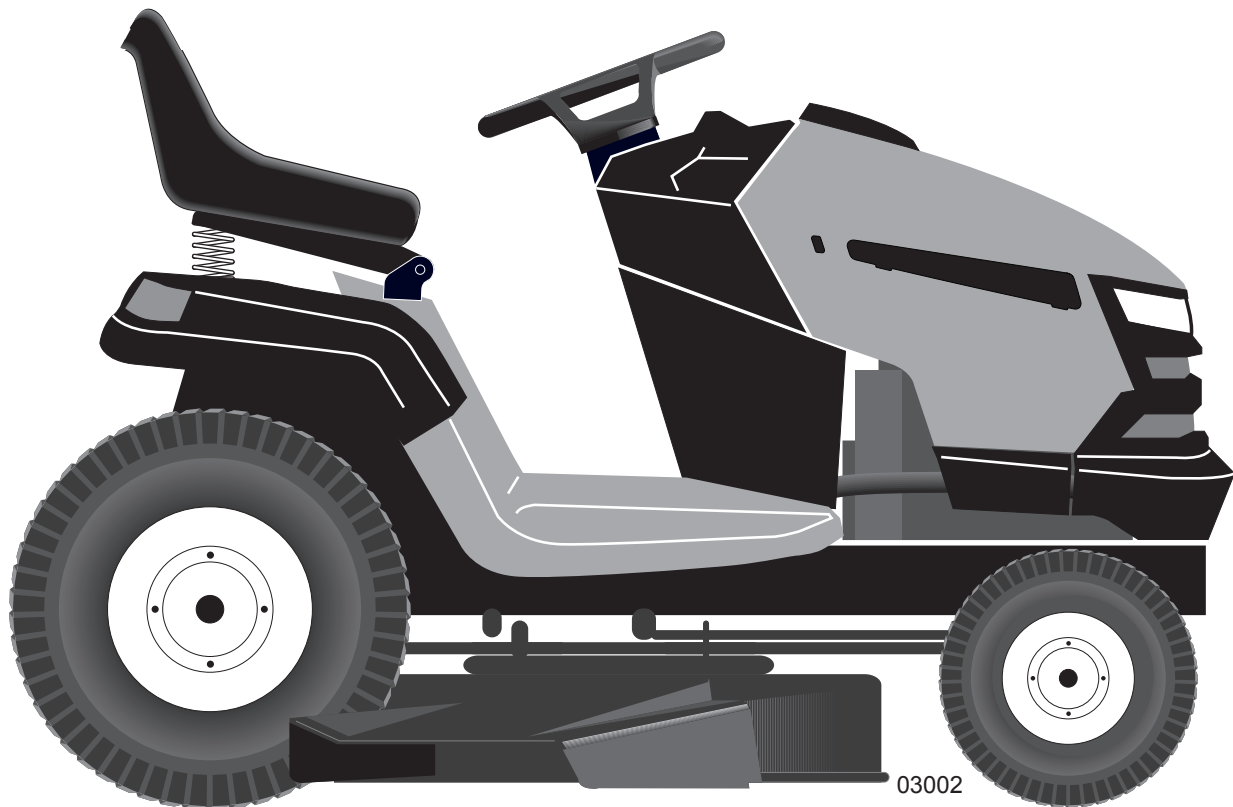

Illustrated Parts List

TRACTOR -- MODEL NUMBER YTH20K46 (96043003301), PRODUCT NO. 960 43 00-33 SCHEMATIC

SCH10

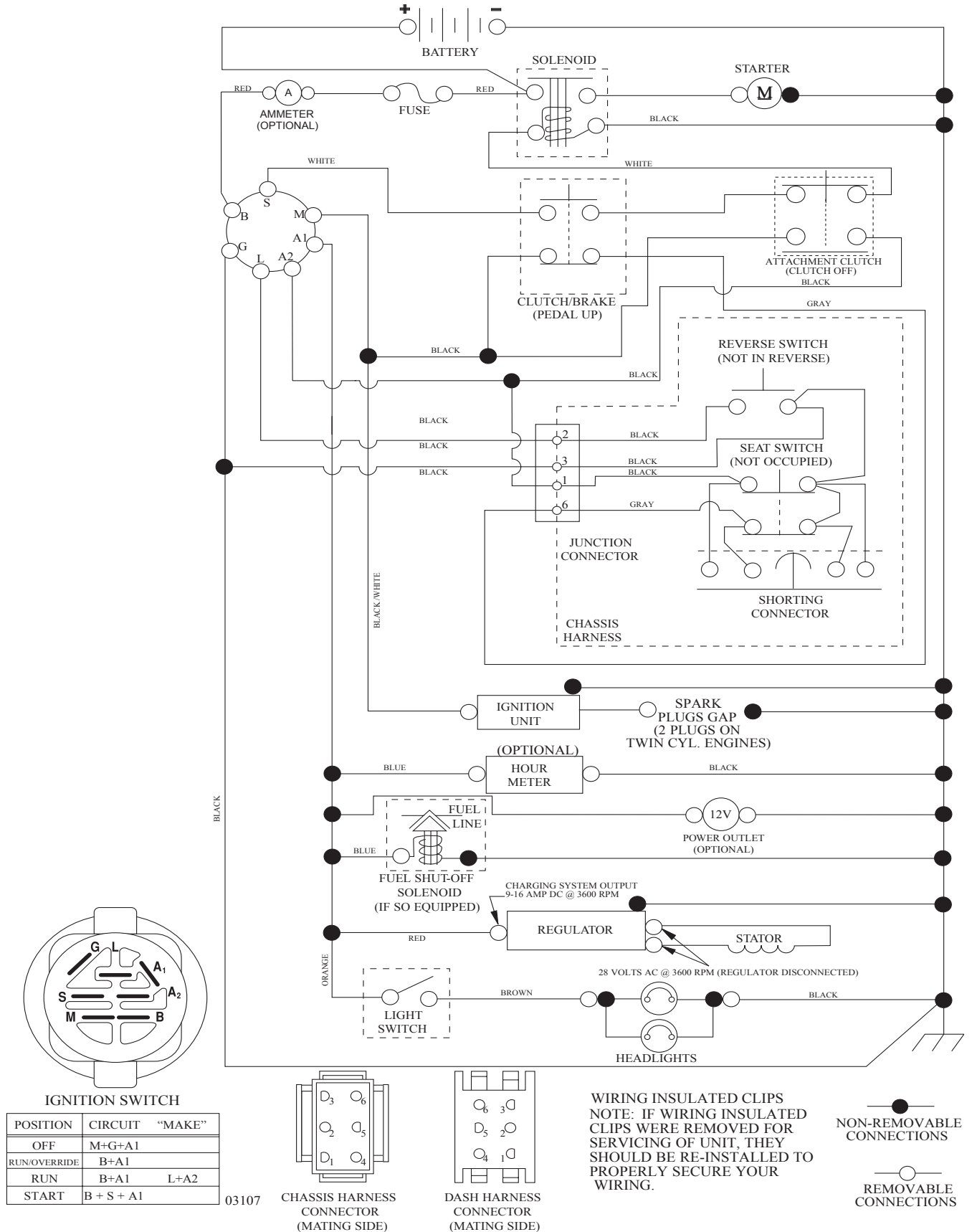

**TRACTOR - - MODEL NUMBER YTH20K46 (96043003301), PRODUCT NO. 960 43 00-33
ELECTRICAL**

KEY NO.	PART NO.	DESCRIPTION
1	532 16 34-65	Battery
2	874 76 04-12	Bolt Hex Head 1/4-20 x 3/4
8	532 19 32-28	Box Battery
16	532 17 61-38	Switch Interlock Push-In
21	532 18 37-59	Harness Socket Light w/4152J
22	532 00 41-52	Bulb Light
25	532 41 28-95	Cable Starter
26	532 17 51-58	Fuse
27	873 51 04-00	Nut Keps Hex 1/4-20 unc
28	532 19 88-85	Cable, Ground
29	532 40 15-45	Switch, Seat
30	532 19 33-50	Switch, Ign
33	532 41 19-35	Key/Chain
34	532 11 07-12	Switch Light/Reset
40	532 40 10-98	Harness Ign.
41	817 72 04-08	Screw Thd Cut 1/4-20 x 1/2
42	532 13 15-63	Cover, Terminal
43	532 19 25-07	Solenoid
46	532 40 17-63	Gauge Servicere minder Hrmtr
55	817 06 05-12	Screw Thdrol 5/16-18 x 3/4 TYTT
71	532 40 04-49	Harness Ign. Dash
79	532 17 52-42	Socket Asm. Bulb
87	532 19 78-02	Switch Interlock Clutch
90	532 40 07-25	Cover Terminal
102	532 40 44-54	Harness Pigtail

NOTE: All component dimensions given in U.S. inches
1 inch = 25.4 mm

**TRACTOR -- MODEL NUMBER YTH20K46 (96043003301), PRODUCT NO. 960 43 00-33
CHASSIS**

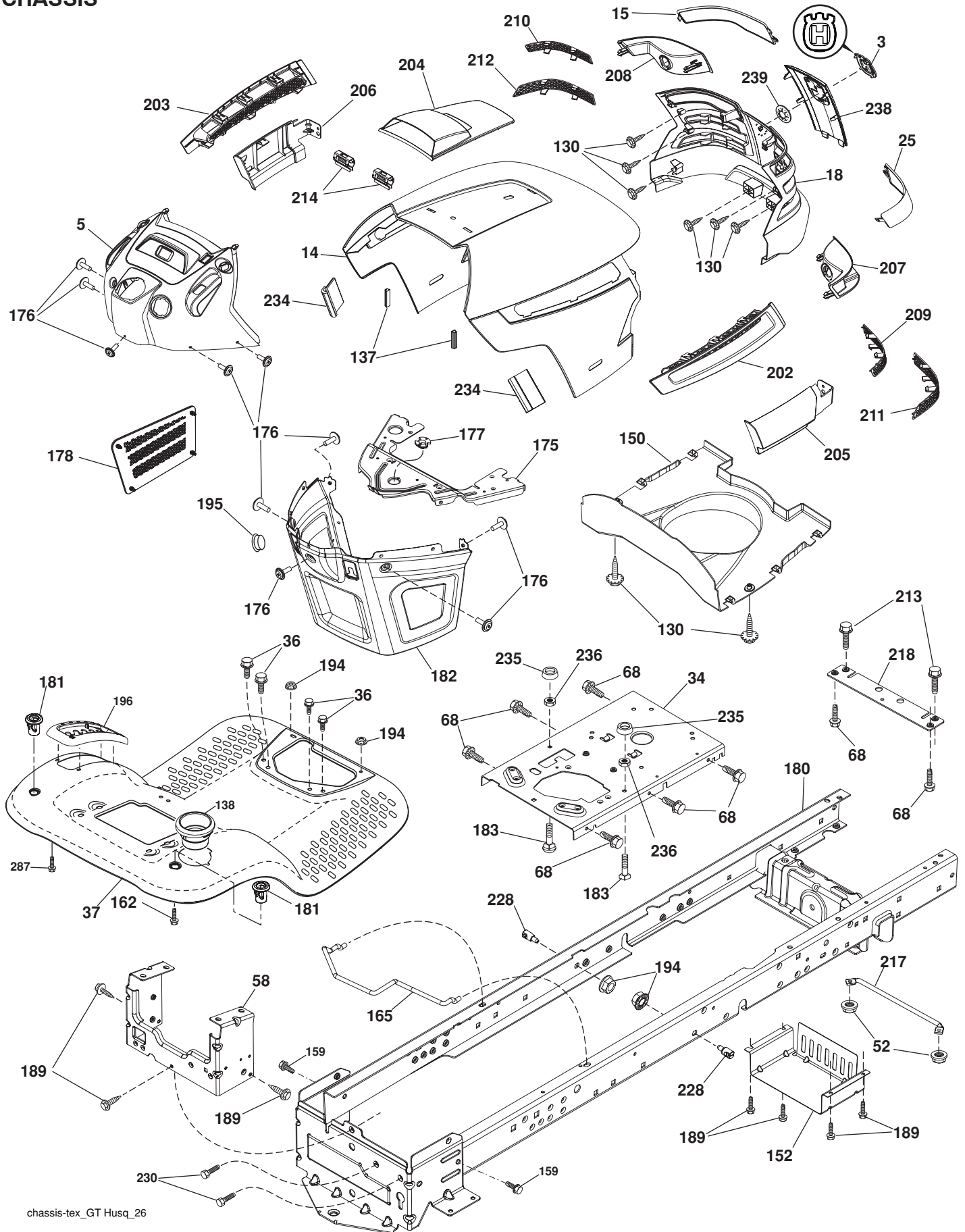

chassis-tex_GT Husq_26

**TRACTOR -- MODEL NUMBER YTH20K46 (96043003301), PRODUCT NO. 960 43 00-33
CHASSIS**

KEY NO.	PART NO.	DESCRIPTION	KEY NO.	PART NO.	DESCRIPTION
3	532 40 50-12	Logo	195	532 40 41-37	Plug Hole Dash Lower
14	532 41 10-46	Hood	196	532 41 91-96	Console Asm. Deck Lift
15	532 19 89-07	Lens LH	202	532 40 30-48	Vent Side Hood RH
18	532 40 86-07	Grille Asm.	203	532 40 30-76	Vent Side Hood LH
25	532 19 89-06	Lens RH	204	532 41 66-13	Vent Top Hood
34	532 19 61-25	Plate Engine	205	532 40 17-09	Skirt Hood Side RH
36	817 06 05-12	Screw 5/16-18 x 3/4	206	532 40 17-11	Skirt Hood Side LH
37	532 41 87-14	Fender	207	532 19 71-98	Bezel RH
52	873 68 05-00	Nut Lock 5/16-18	208	532 19 71-99	Bezel LH
58	532 41 22-80	Drawbar Upper	209	532 19 91-30	Insert Hex Top RH
68	817 49 05-08	Screw Thdrol 5/16-18 x 1/2	210	532 19 91-31	Insert Hex Top LH
130	532 41 63-58	Screw #10 x 0.750	211	532 19 91-32	Insert Hex Bottom RH
137	532 40 75-90	Bumper Dash	212	532 19 91-33	Insert Hex Bottom LH
138	532 40 29-54	Cupholder	213	874 76 05-12	Bolt 5/16-18 x 3/4
150	532 19 85-13	Air Duct	214	532 19 91-45	Clip Retainer Tinner
152	532 19 95-35	Shield Browning	217	532 40 91-67	Rod Pivot
159	817 00 06-12	Screw 3/8-16 x 3/4	218	532 19 63-95	X-Piece Hood Stop
162	532 14 24-32	Screw	228	532 19 51-61	Stud Fastner
175	532 19 63-04	Crossmember	230	532 17 01-65	Bolt Shoulder 5/16-18
176	532 40 07-76	Screw 10-24 x 5/8	234	532 40 47-42	Bumper Hood
177	532 19 52-27	Bushing Steering	235	532 40 61-29	Spacer Fender
178	532 19 97-82	Cargo Net Asm.	236	873 93 05-00	Nut Lock 5/16-18 unc
180	532 41 50-63	Chassis	238	532 40 86-06	Trim
181	532 40 30-25	Bushing Mtg. Fender Crgo	239	532 11 04-52	Nut, Push
182	532 40 68-59	Dash Lower	287	817 60 04-06	Screw 1/4-20 x 3/8
183	874 78 05-20	Bolt Fin Hex 5/16-18 unc x 1-1/4			
189	817 00 05-12	Screw 5/16-18 x 3/4			
194	873 90 05-00	Nut Lock Hex Flange 5/16-18			

NOTE: All component dimensions given in U.S. inches
1 inch = 25.4 mm

TRACTOR -- MODEL NUMBER YTH20K46 (96043003301), PRODUCT NO. 960 43 00-33
DRIVE

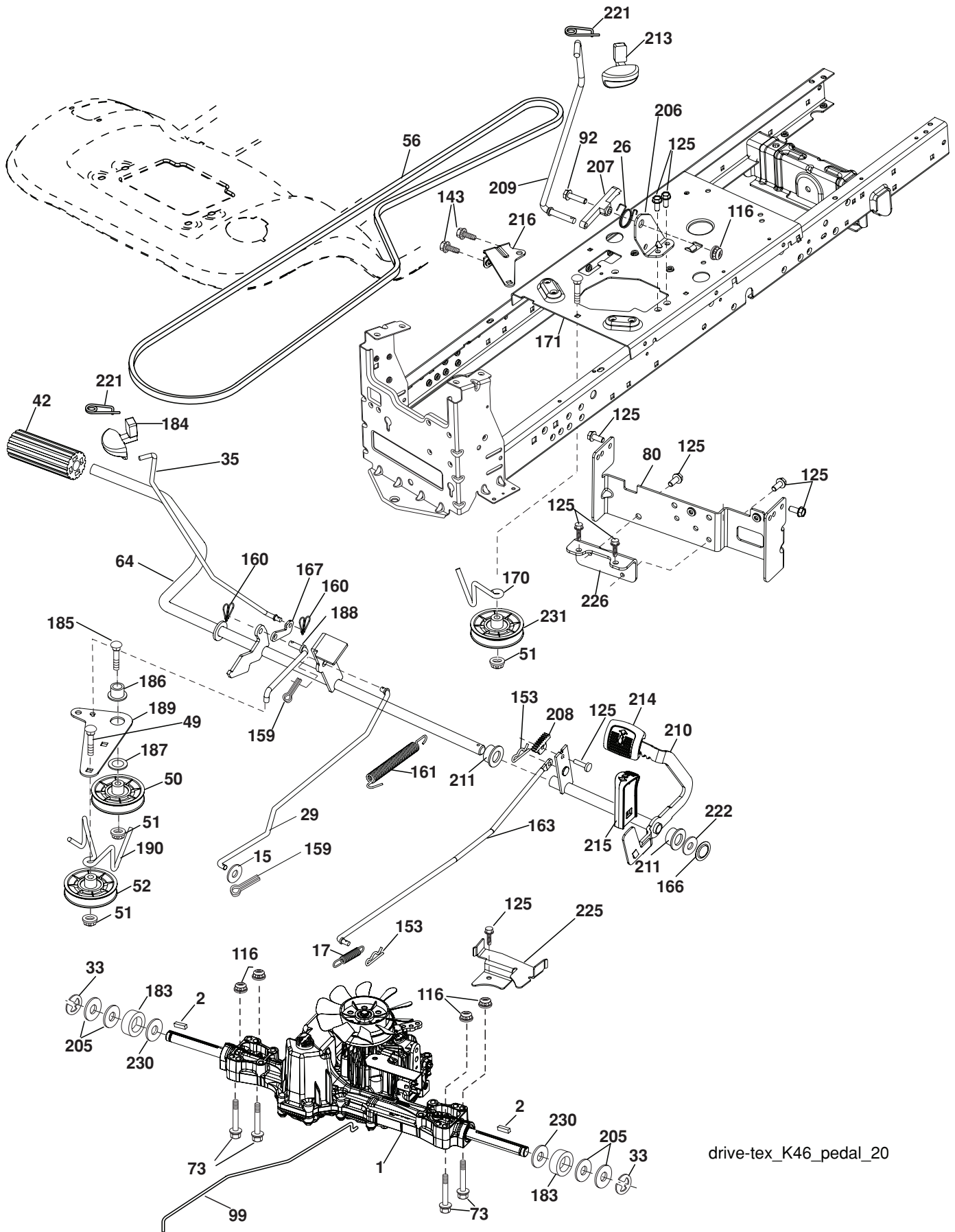

drive-tex_K46_pedal_20

**TRACTOR -- MODEL NUMBER YTH20K46 (96043003301), PRODUCT NO. 960 43 00-33
DRIVE**

KEY NO.	PART NO.	DESCRIPTION	KEY NO.	PART NO.	DESCRIPTION
1	532 40 53-84	Transaxle, TUFFTORQ K46	170	532 41 34-30	Keeper Belt Centerspan
			171	872 11 06-22	Bolt
2	532 12 35-83	Key Square	183	532 13 70-57	Spacer Axle
15	819 13 13-16	Washer 13/32 x 13/16 x 16 Ga.	184	532 40 31-18	Handle Parking Brake
17	532 41 36-78	Spring, Brake	185	872 11 06-20	Bolt
26	532 19 96-79	Spring Return Cruise	186	532 19 43-21	Spacer Retainer
29	532 40 38-06	Rod, Brake	187	819 13 32-10	Washer
33	812 00 00-01	Ring E	188	532 19 43-23	Link Clutch Ground Drive
35	532 19 95-91	Rod, Brake, Park	189	532 19 43-17	Bellcrank Ground Drive
42	532 12 48-72	Cover, Foot Pedal	190	532 19 43-18	Keeper Bellcrank Ground Drive
49	872 11 06-14	Bolt	205	532 12 17-48	Washer 25/32 x 1-5/8 16 Ga.
50	532 19 43-27	Pulley Idler Flat	206	532 19 78-67	Bracket Mount Latch Cruise
51	873 90 06-00	Lock Nut 3/8-16	207	532 19 78-68	Latch Control Cruise
52	532 19 43-26	Idler V-Groove 910" Offset	208	532 19 78-69	Gear Sector Control Cruise
56	532 13 09-69	V-Belt, Drive	209	532 19 95-92	Rod Control Cruise
64	532 19 78-65	Shaft Asm. Pedal Brake Control	210	532 40 09-80	Rockr Asm. Pedal Control
73	874 49 05-60	Bolt Hex 5/16-18 Gr. 5	211	532 12 01-83	Bearing Nylon
80	532 41 00-24	Strap Torque	213	532 40 31-19	Knob control Cruise
92	874 76 05-20	Bolt Fin Hex 5/16-18 unc x 1.25	214	532 40 17-22	Pad Pedal Forward
99	532 41 57-42	Rod Spring Bypass	215	532 40 17-23	Pad Pedal Reverse
116	873 90 05-00	Nut Lock Hex Flange 5/16-18	216	532 19 61-31	Bracket Pulley Idler
125	817 00 05-12	Screw 5/16-18 x 3/4	221	532 40 31-87	Retainer Spring Clip
143	817 49 05-08	Screw 5/16-18 x 1/2	222	879 21 20-10	Washer 21/32 x 1-1/4 10 Ga.
153	532 12 47-88	Retainer Spring	225	532 40 33-19	Keeper Bolt Transaxle
159	876 02 04-12	Pin Cotter 1/8 x 3/4	226	532 40 15-64	Bracket Mount Torque
160	532 16 94-84	Retainer Clip	230	532 18 89-67	Washer Hardened
161	532 10 57-09	Spring, Return, Clutch	231	532 40 72-87	Idler V-Groove 1.688" OFFSET
163	532 40 10-34	Rod Pedal Control			
166	532 19 72-90	Nut Push			
167	532 40 52-57	Latch Brake Parking			

NOTE: All component dimensions given in U.S. inches
1 inch = 25.4 mm

TRACTOR -- MODEL NUMBER YTH20K46 (96043003301), PRODUCT NO. 960 43 00-33
STEERING ASSEMBLY

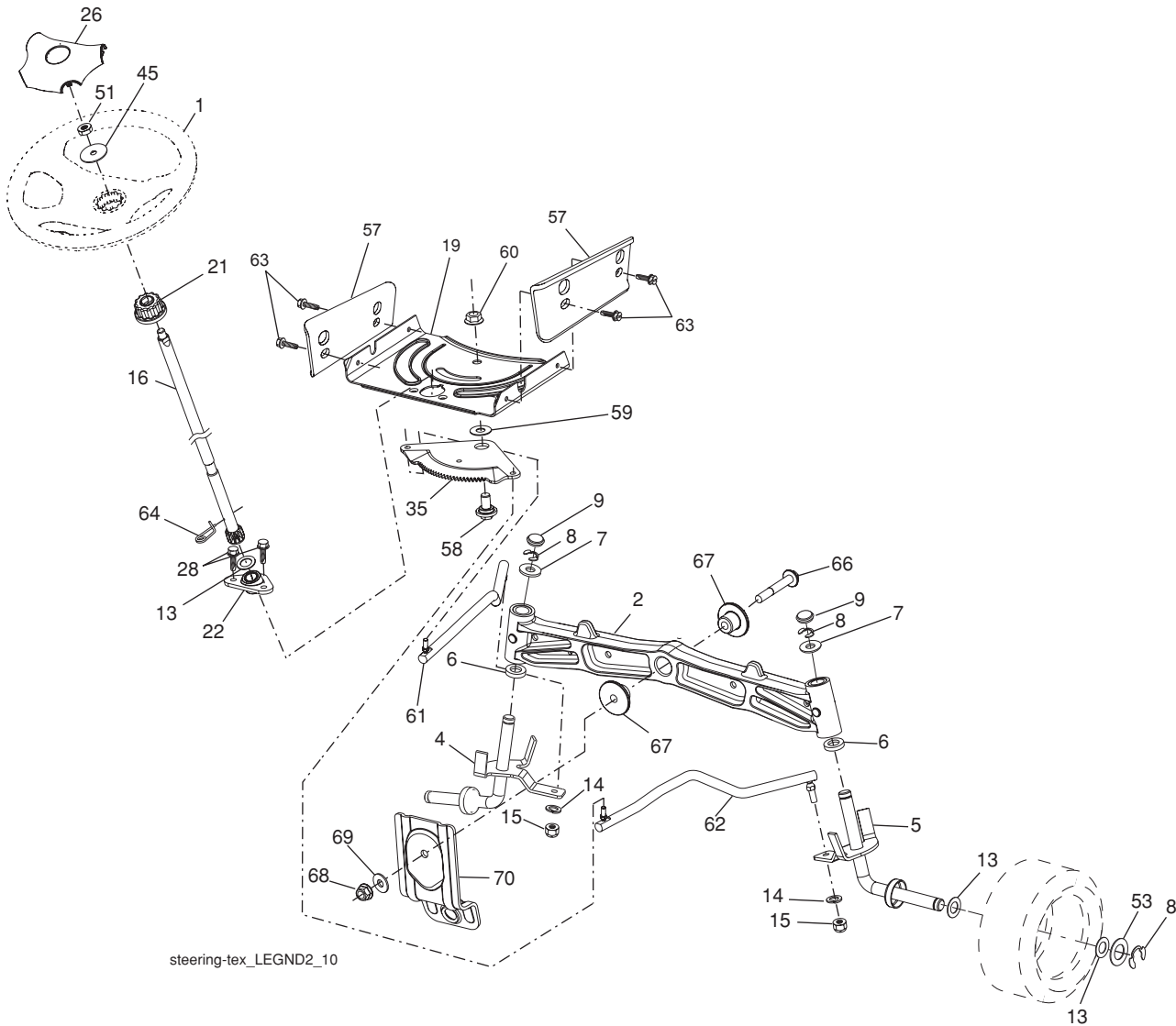

steering-tex_LEGND2_10

KEY NO.	PART NO.	DESCRIPTION	KEY NO.	PART NO.	DESCRIPTION
1	532 19 39-43	Wheel, Steering	45	819 18 38-12	Washer 9/16 ID x 2-3/8 OD 12 Ga.
2	532 18 47-06	Axle Asm., Front	51	873 94 08-00	Nut Hex Jam Toplock 1/2-20 unf
4	532 40 30-87	Spindle Asm., LH	53	532 18 89-67	Washer Hardened .793x1.637x.060
5	532 40 30-88	Spindle Asm., RH	57	532 40 74-65	Bracket Upstop
6	532 12 49-31	Bearing, Race Thrust Harden	58	532 19 47-47	Bolt Shoulder Sector Pivot CFM
7	532 12 17-48	Washer 25/32 x 1-5/8 x 16 Ga.	59	532 19 47-48	Washer Thrust Sector Steering
8	812 00 00-29	Ring, Clip #T5304-75	60	873 97 10-00	Nut Flange Lock 5/8-11
9	532 12 12-32	Cap, Spindle	61	532 19 47-40	Draglink LH
13	532 12 17-49	Washer 25/32 x 1-1/4 x 16 Ga.	62	532 19 47-41	Draglink, RH
14	810 04 06-00	Washer, Lock Hvy Hlcl Spr 3/8	63	817 00 05-12	Screw 5/16-18 x 3/4
15	873 54 06-00	Nut, Crown Lock 3/8-24 unf	64	532 19 98-49	Retainer Clip Spring Steering
16	532 40 82-19	Shaft Steering	66	871 02 07-48	Bolt Hex Fghd 7/16-14 x 3 Serr
19	532 19 47-29	Plate Steering	67	532 19 47-37	Bushing PM Front Axle
21	532 18 67-37	Adapter, Wheel Steering	68	873 90 07-00	Nut Lock Flange 7/16-14 Gr. 5
22	532 19 48-45	Bushing, Strg. Blk	69	532 19 91-62	Washer 1.5 x .505 x .118
26	532 19 36-52	Insert, Wheel Steering	70	532 19 61-97	Bracket Deck Susp. Front
28	817 00 06-12	Screw 3/8-16 x 3/4			
35	532 19 47-32	Gear, Sector Plate			

NOTE: All component dimensions given in U.S. inches
 1 inch = 25.4 mm

**TRACTOR -- MODEL NUMBER YTH20K46 (96043003301), PRODUCT NO. 960 43 00-33
ENGINE**

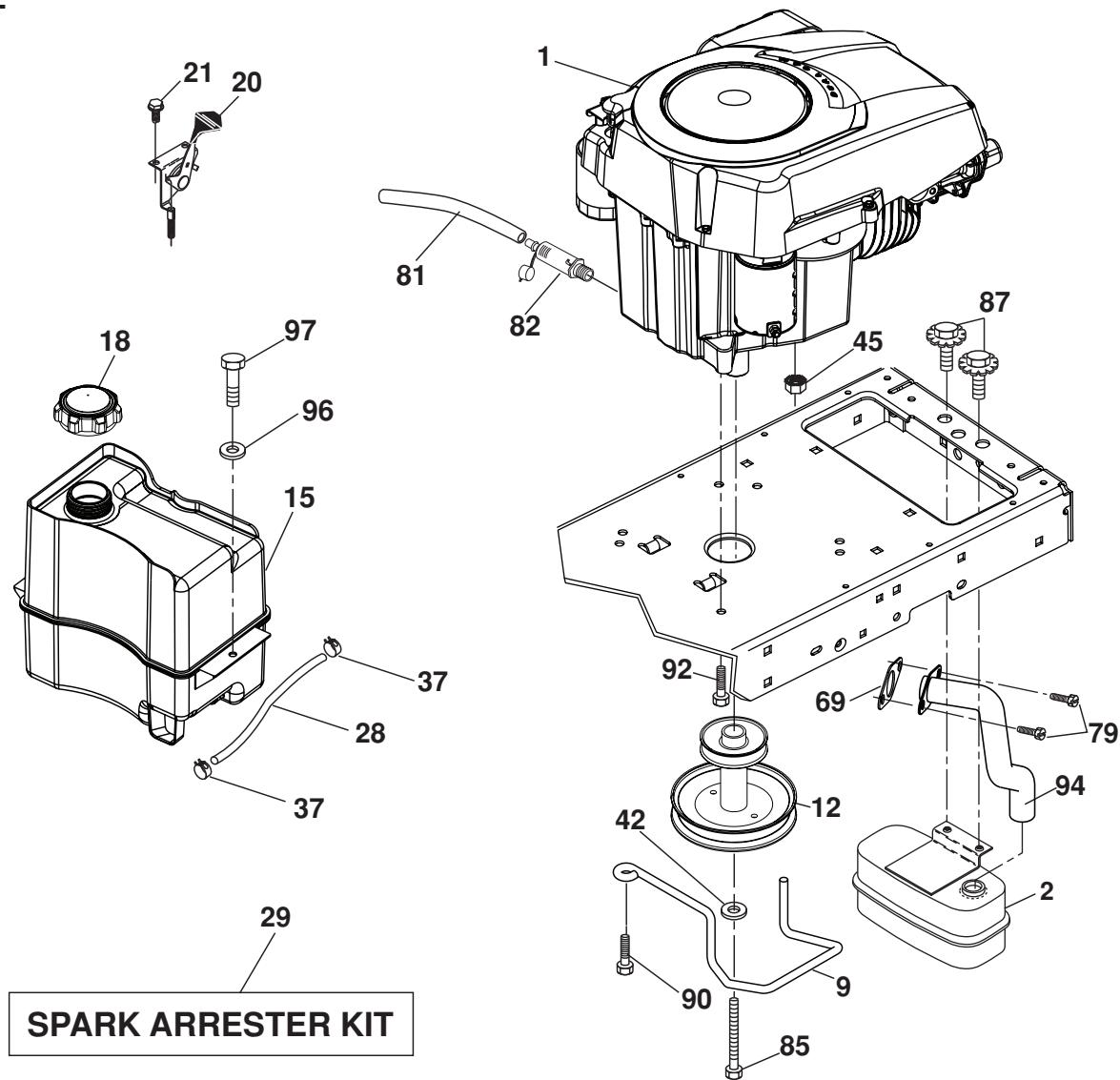

SPARK ARRESTER KIT

engine-tex_Kohl_6

KEY NO.	PART NO.	DESCRIPTION
1	-----	Engine Kohler Model No. SV600
2	532 18 86-55	Muffler
9	532 19 43-20	Keeper Belt Engine
12	532 40 54-72	Pulley Engine
15	532 40 74-89	Tank Fuel
18	532 19 77-25	Cap Asm
20	532 40 15-08	Control Throttle
21	532 41 63-58	Screw #10 x 0.750
28	532 40 11-37	Fuel Line
29	532 13 71-80	Spark Arrester Kit
37	532 12 34-87	Clamp Hose
42	810 04 07-00	Washer Lock 7/16
45	873 51 04-00	Nut Keps Hex 1/4-20 unc
69	532 18 59-09	Gasket
79	532 19 23-34	Screw Socket Hd. 5/16-18 x .75
81	532 14 84-56	Tube Drain Oil Easy
82	532 18 16-54	Plug Drain Oil

KEY NO.	PART NO.	DESCRIPTION
85	532 17 39-37	Bolt Hex 7/16-20x4xGr.5-1.5 Thr
87	537 17 18-77	Bolt 5/16-18 unc x 3/4 w/Sems
96	819 09 14-16	Washer 9/32 x 7/8 x 16 Ga.
97	817 67 04-12	Screw 1/4-20 x 3/4
90	817 00 06-16	Screw 3/8-16 x 1
92	817 12 06-16	Screw 3/8-16 x 1
94	532 18 86-54	Tube Exhaust

NOTE: All component dimensions given in U.S. inches
1 inch = 25.4 mm

For engine service and replacement parts, call the toll free number for your engine manufacturer listed below:

Kohler Co. 1-800-544-2444

**TRACTOR -- MODEL NUMBER YTH20K46 (96043003301), PRODUCT NO. 960 43 00-33
SEAT ASSEMBLY**

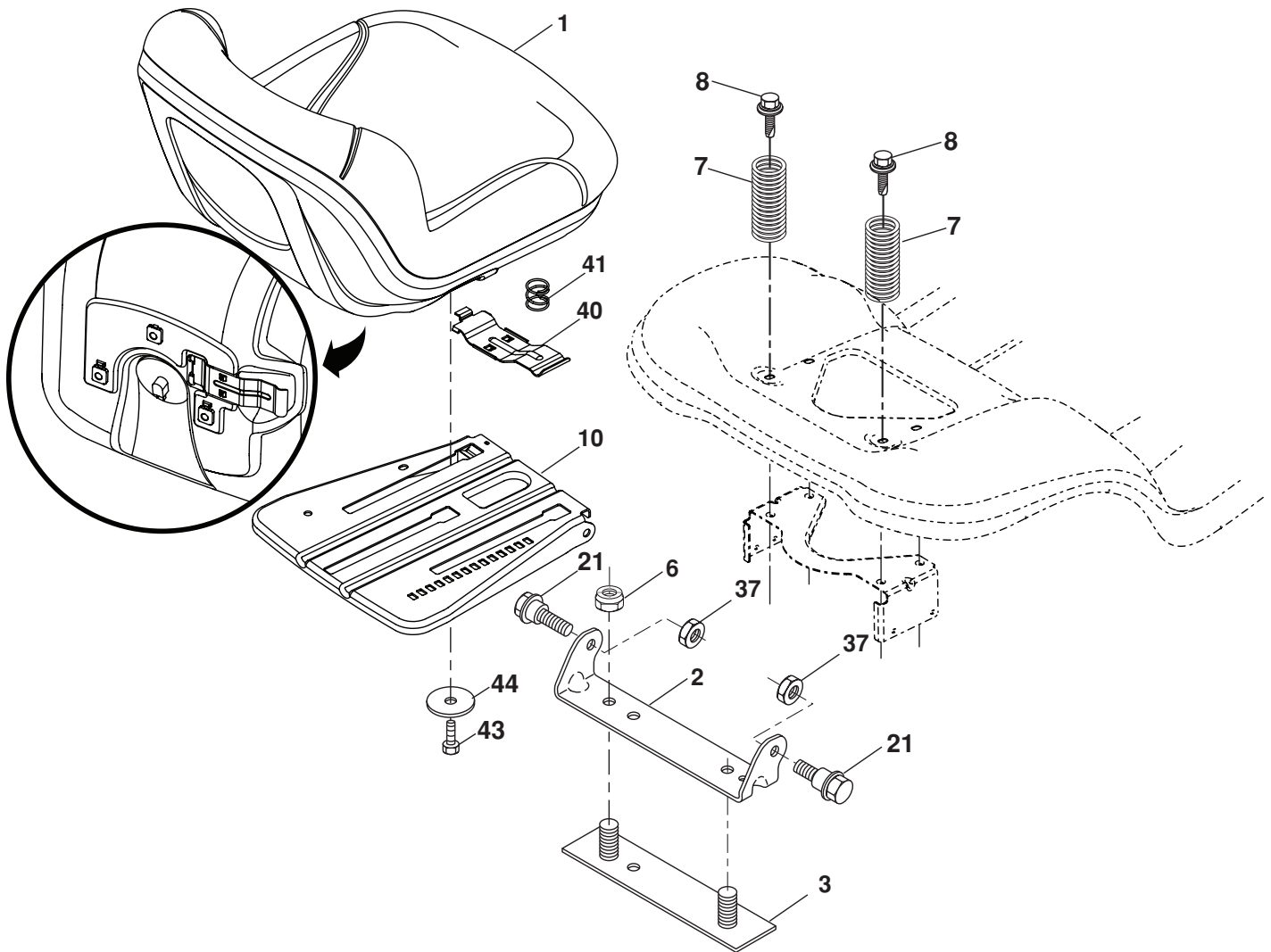

seat-tex_7-vgt

KEY NO.	PART NO.	DESCRIPTION
1	532 19 75-18	Seat
2	532 18 01-66	Bracket Pivot Fender
3	532 14 06-75	Strap, Asm Fender
6	873 80 06-00	Nut, Lock w/Ins. 3/8-16 unc
7	532 12 41-81	Spring, Seat Cprsn
8	532 17 18-77	Bolt 5/16-18 unc x 3/4 w/Sems
10	532 19 69-77	Pan, Seat
21	532 17 18-52	Bolt, Shoulder 5/16-18

KEY NO.	PART NO.	DESCRIPTION
37	873 80 05-00	Nut, Lock 5/16-18 unc
40	532 19 76-61	Handle Slide Seat
41	532 19 82-00	Spring Latch Seat
43	874 76 06-12	Bolt Fin Hex 3/8-16 unc x 3/4
44	819 13 38-12	Washer 13/32 x 2-3/8 x 12 Ga.

NOTE: All component dimensions given in U.S. inches
1 inch = 25.4 mm

**TRACTOR -- MODEL NUMBER YTH20K46 (96043003301), PRODUCT NO. 960 43 00-33
DECALS**

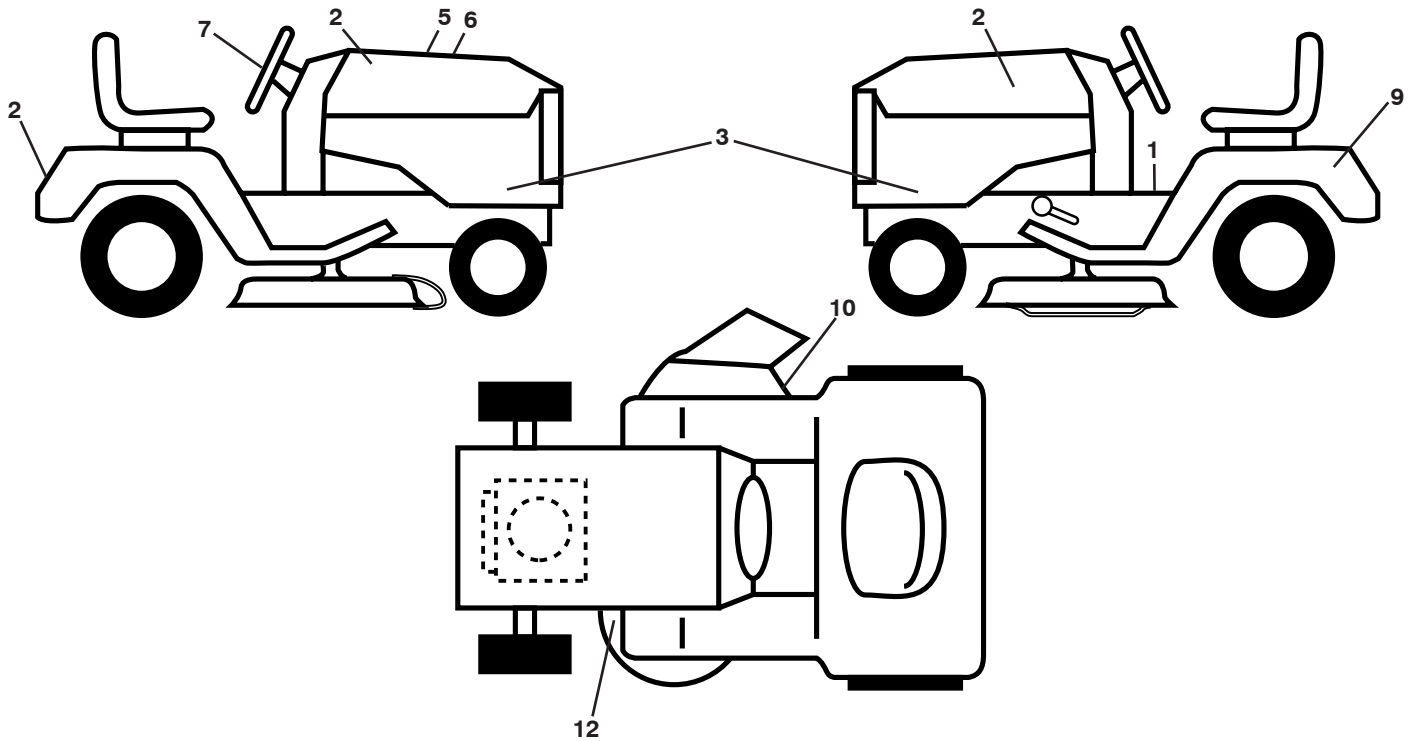

KEY NO.	PART NO.	DESCRIPTION
1	532 41 16-58	Decal, Warning
2	532 40 28-32	Decal, Hood
3	532 41 01-08	Decal, Hood Panel SD
5	532 18 09-41	Decal, Customer Respons.
6	532 41 00-27	Decal, Replacement
7	532 40 44-84	Decal, Steering Wheel
9	532 14 50-05	Decal, Battery Dnge/Poi

KEY NO.	PART NO.	DESCRIPTION
10	532 17 05-63	Decal, Warning
12	532 16 03-96	Decal, Mower V-Belt Schematic
--	532 16 69-60	Decal, Bypass
--	532 41 08-05	Pad, Footrest, LH
--	532 41 08-06	Pad, Footrest, RH

WHEELS AND TIRES

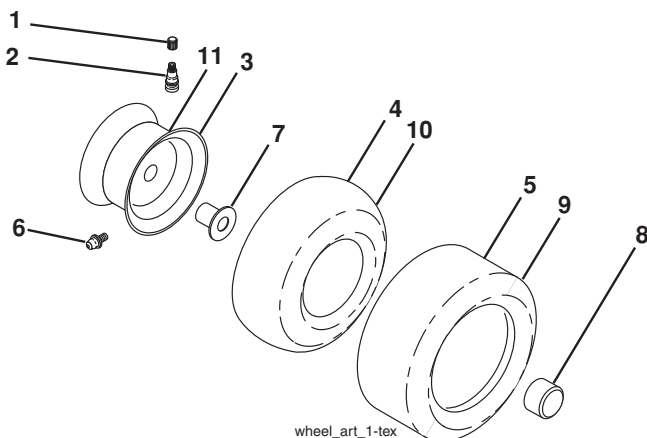

KEY NO.	PART NO.	DESCRIPTION
1	532 05 91-92	Cap Valve Tire
2	532 06 51-39	Stem Valve
3	532 13 83-36	Rim Front Service
4	532 05 99-04	Tube Front (Service Item Only)
5	532 10 62-22	Tire Front 15 x 6.0-6 Service
6	532 12 49-57	Fitting Grease (Front Wheel Only)
7	532 12 49-59	Bearing Flange (Front Wheel Only)
8	532 17 50-39	Cap Axle Blk 1 50 x 1 00
9	532 10 62-68	Tire R T 18 x 9.5-8 Service
10	532 12 49-26	Tube Rear (Service Item Only)
11	532 13 83-37	Rim Asm 8" rear Service
--	532 14 43-34	Sealant, Tire (10 oz. Tube)

NOTE: All component dimensions given in U.S. inches
1 inch = 25.4 mm

TRACTOR -- MODEL NUMBER YTH20K46 (96043003301), PRODUCT NO. 960 43 00-33 MOWER DECK

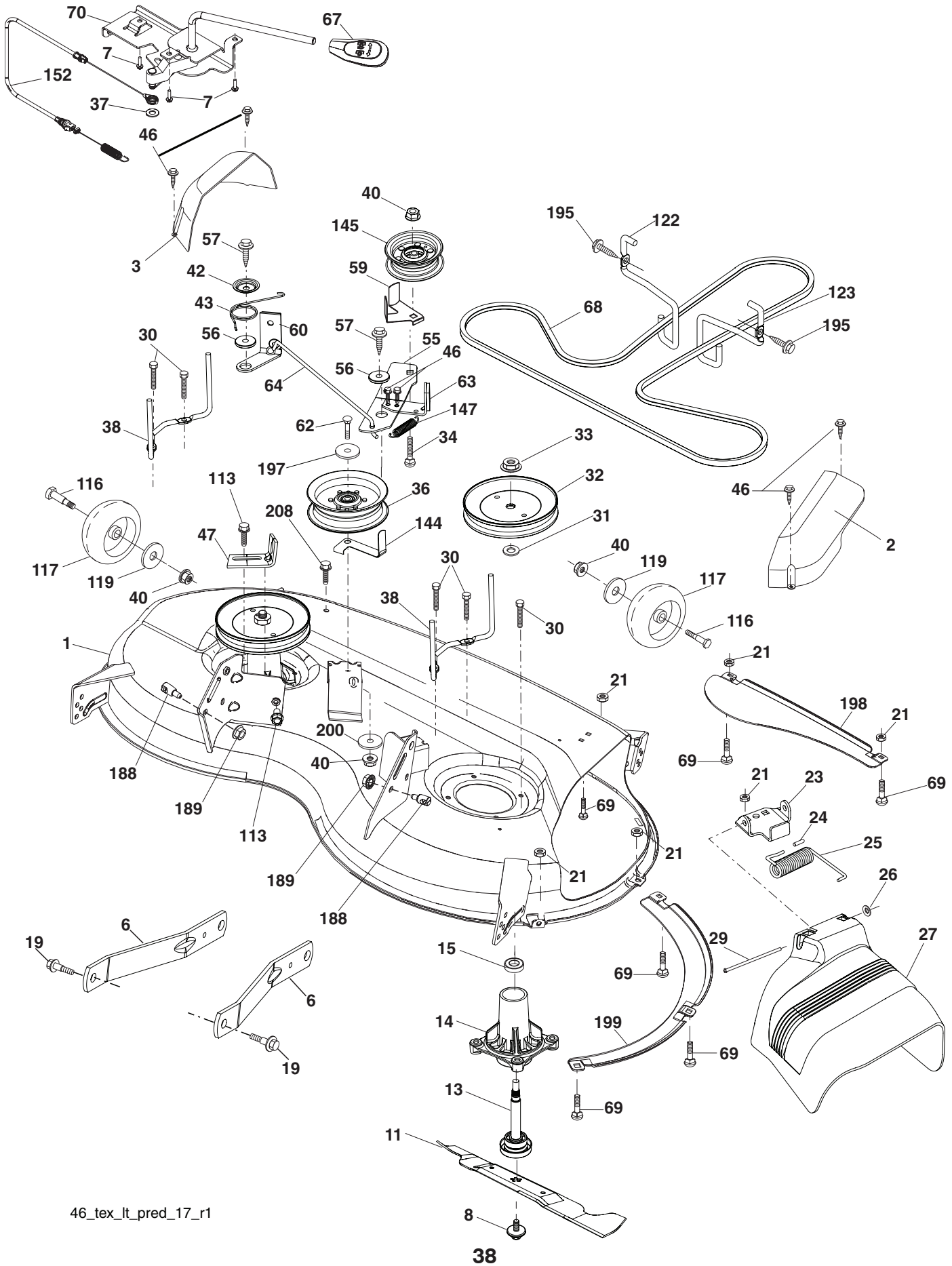

**TRACTOR -- MODEL NUMBER YTH20K46 (96043003301), PRODUCT NO. 960 43 00-33
MOWER DECK**

KEY PART NO. NO.	DESCRIPTION	KEY PART NO. NO.	DESCRIPTION
1	532 41 08-63	62	874 52 06-36
2	532 40 55-06	63	532 19 94-78
3	532 40 55-07	64	532 40 51-39
6	532 19 51-86	67	532 40 30-12
7	532 41 63-58	68	532 40 51-43
8	532 19 30-03	69	872 14 05-05
11	532 40 53-80	70	532 40 65-63
13	532 19 28-72	113	817 00 05-10
14	532 18 72-81	116	532 19 34-06
15	532 11 04-85	117	532 17 48-73
19	532 19 65-39	119	819 13 20-12
21	873 68 05-00	122	532 19 72-58
23	532 19 25-57	123	532 19 72-59
24	532 10 53-04	144	532 19 92-04
25	532 19 70-26	145	532 19 31-97
26	532 11 04-52	147	532 40 18-72
27	532 40 53-57	152	532 40 83-19
29	532 13 14-91	188	532 19 51-61
30	532 17 39-84	189	873 90 05-00
31	532 18 76-90	195	817 00 06-12
32	532 19 74-73	197	819 13 13-12
33	532 40 02-34	198	532 40 31-49
34	872 11 06-12	199	532 40 31-50
36	532 19 73-79	200	532 41 35-24
37	819 13 13-16	208	817 67 06-08
38	532 19 91-89		
40	873 90 06-00	--	532 19 28-70
42	532 19 84-10		
43	532 19 72-56		
46	532 13 77-29		
47	532 19 72-50		
55	532 19 72-49	--	532 40 84-78
56	532 19 90-92		
57	817 00 06-16		
59	532 14 10-43		
60	532 19 94-71		
	Mower Housing		Bolt 3/8-16 unc x 2-1/4 Gr. 5
	Cover Mandrel RH		Arm Brake Mower
	Cover Mandrel LH		Linkage Brake
	Arm Suspension		Handle, Clutch Cable
	Screw #10 x 0.750		V-Belt
	Bolt/Washer asm 7/16-20 unf		Bolt
	Blade Mower		Clutch Asm. Cable
	Shaft Assembly, Mandrel		Screw 5/16-18
	Housing, Mandrel		Bolt, Shoulder
	Bearing, Ball, Mandrel		Wheel, Gauge
	Bolt, Shoulder		Washer 13/32 x 1-1/4 x 12 Ga.
	Nut		Keeper Belt Eng. LH
	Bracket, Deflector		Keeper Belt Eng. RH
	Cap, Sleeve		Keeper Belt
	Spring, Torsion, Deflector		Pulley Idler
	Nut, Push		Spring Return
	Shield, Deflector		Cable Clutch Manual w/Spr.
	Rod, Hinge		Stud Fastener
	Screw Thdrol Rolling Wsh Hd		Nut Lock Hex Flange
	Washer, Spacer		Screw 3/8-16 x 3/4
	Pulley, Mandrel		Washer 13/32 x 13/16 x 12 Ga.
	Nut, Toplock, Flanged		Baffle Center Front
	Bolt Carr Sh. 3/8-16 x 1-1/2 Gr. 5		Baffle Front RH
	Pulley, Idler, Flat		Washer 13/32 x 1 x 1/2 11 Ga.
	Washer 13/32 x 13/16 x 16 Ga.		Screw 3/8-16 x 1/2
	Keeper Belt LH Mandrel		
	Nut, Lock Flg. 3/8-16 unc		Mandrel Assembly (Includes housing, shaft assembly, and bearing only - pulley/nut/washer and blade bolt/washers not included)
	Spring Trosion Brake		
	Spring Torsion Retainer		
	Screw		
	Bracket Clutch Cable		
	Arm, Idler		Replacement Mower, Complete
	Spacer, Retainer		
	Screw Hexwsh Thd 3/8-16 x 1		
	Guard, Tuv Idler (94)		
	Arm Brake Mower LH		

NOTE: All component dimensions given in U.S. inches
1 inch = 25.4 mm

**TRACTOR -- MODEL NUMBER YTH20K46 (96043003301), PRODUCT NO. 960 43 00-33
MOWER LIFT**

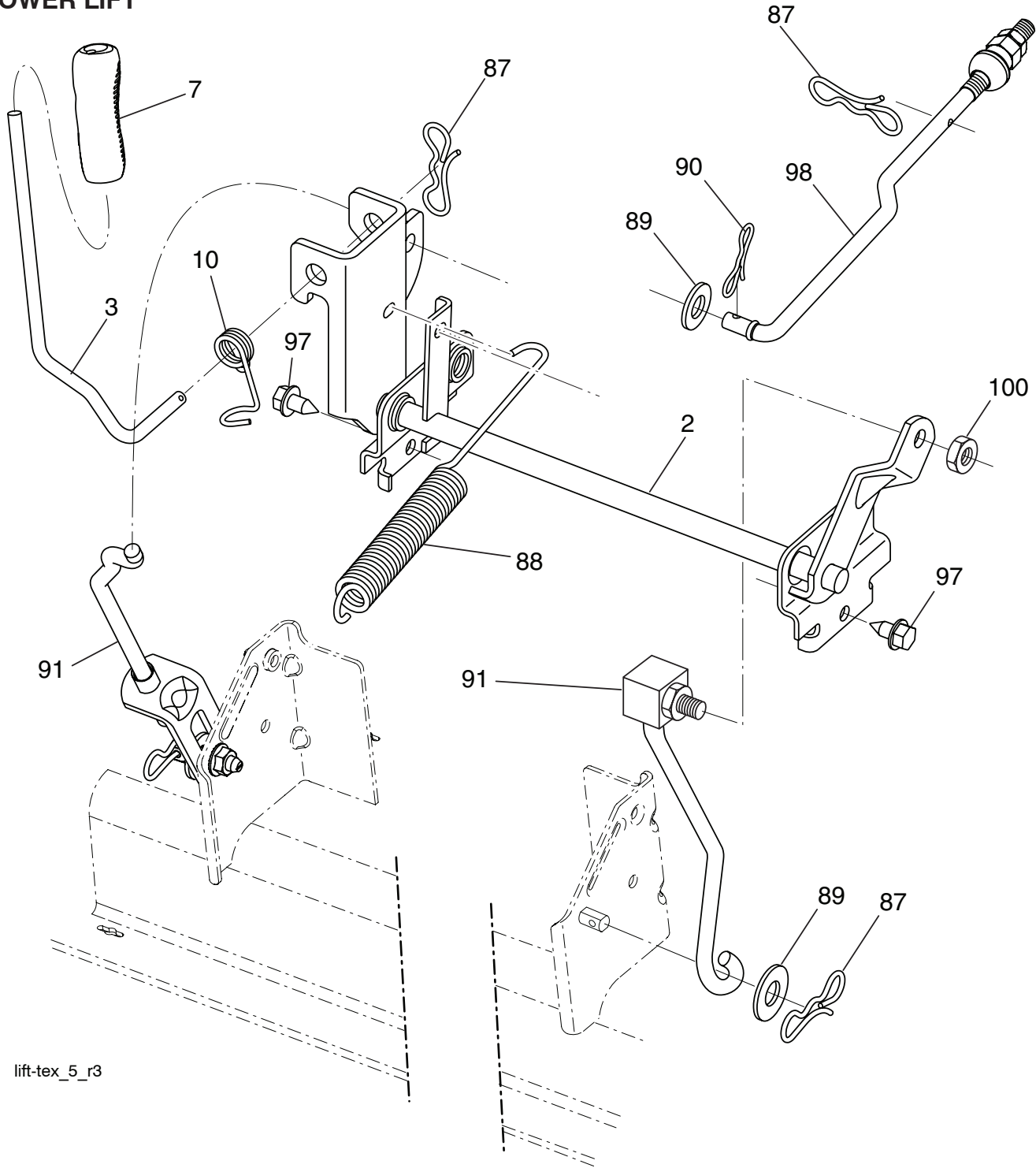

lift-tex_5_r3

KEY NO.	PART NO.	DESCRIPTION
2	532 19 52-23	Shaft Asm., Lift
3	532 19 52-31	Lever Asm., Lift RH
7	532 41 15-55	Grip, Lever
10	532 19 63-14	Spring Torsion
87	532 19 42-09	Pin Cotter 7/16 Bow Tie Lock
88	532 41 07-10	Spring Lift Assist
89	819 19 19-12	Washer Clear Zinc

KEY NO.	PART NO.	DESCRIPTION
90	532 19 42-08	Pin Cotter 5/16 Bow Tie Lock
91	532 19 51-81	Link Lift Susp Mower Rear
97	817 06 06-12	Screw 3/8-16x.75 Smgml Tap/R.Z
98	532 19 52-70	Link Lift Susp. Front Mower
100	873 93 06-00	Nut Center Lock 3/8-16 unc

NOTE: All component dimensions given in U.S. inches
1 inch = 25.4 mm

