

LG T2654

Illustrated Parts List / 96045000702

**TRACTOR - MODEL NO. LGT2654 (96045000702), PRODUCT NO. 960 45 00-07
DECALS**

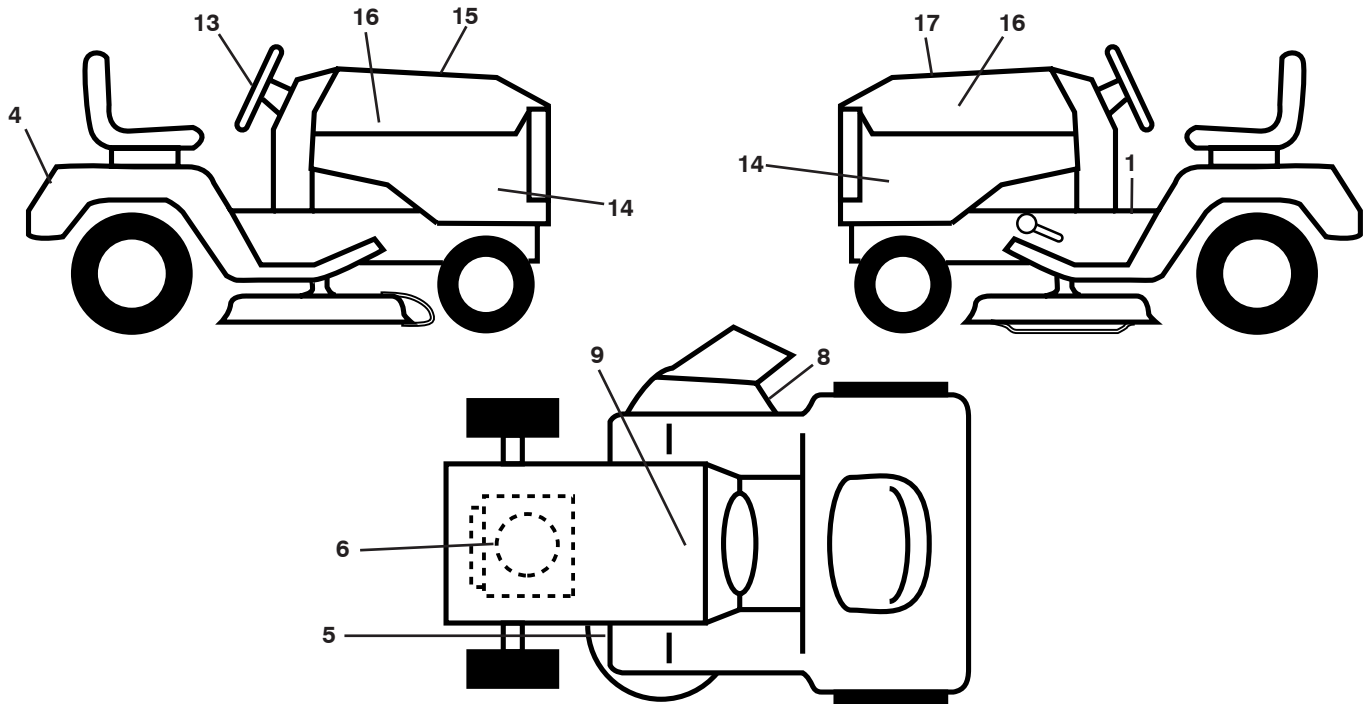

KEY NO.	PART NO.	DESCRIPTION
1	532 41 91-38	Decal, Warning
4	532 19 15-54	Decal, Hood Cust Resp
5	532 17 84-55	Decal, Caution
6	532 41 99-35	Decal, Eng. HP
8	532 19 87-85	Decal, Mower Sch.
9	532 14 50-05	Decal, Battery Dnge/Poi
13	532 40 44-84	Decal, Steering Whl
14	532 41 01-09	Decal, Panel Side

KEY NO.	PART NO.	DESCRIPTION
15	532 18 09-41	Decal, Panel Side
16	532 41 68-38	Decal, Hood Logo
17	532 42 02-38	Decal, Replacement
--	532 16 69-60	Decal, Bypass
--	532 40 17-71	Pad, Footrest, LH
--	532 40 37-73	Pad, Footrest, RH

WHEELS AND TIRES

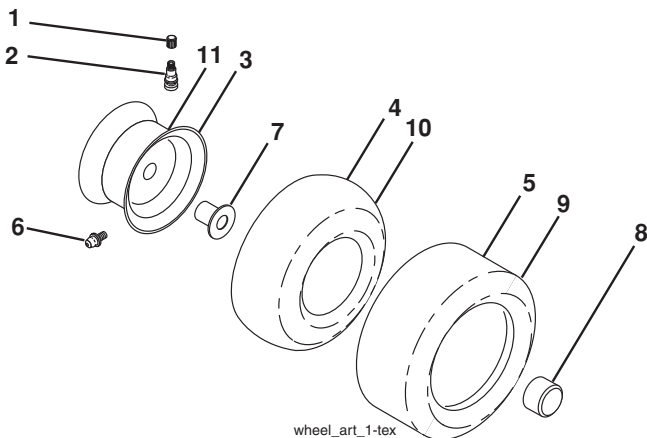

wheel_art_1-tex

KEY NO.	PART NO.	DESCRIPTION
1	532 05 91-92	Cap, Valve, Tire
2	532 06 51-39	Stem, Valve
3	532 14 45-09	Rim Assembly, Front
4	532 00 81-34	Tube, Front (Service Item Only)
5	532 10 62-30	Tire, Front
6	532 12 49-57	Fitting, Grease (Front Wheel Only)
7	532 12 49-59	Bearing, Flange (Front Wheel Only)
8	532 17 50-39	Cap, Axle (Front Wheel Only)
9	532 18 47-08	Tire, Rear
10	532 00 71-54	Tube, Rear (Service Item Only)
11	532 40 17-82	Rim Assembly, Rear
--	532 14 43-34	Sealant, Tire (10 oz. Tube)

NOTE: All component dimensions given in U.S. inches
1 inch = 25.4 mm

TRACTOR - MODEL NO. LGT2654 (96045000702), PRODUCT NO. 960 45 00-07 SCHEMATIC

SCH12

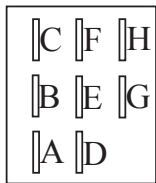
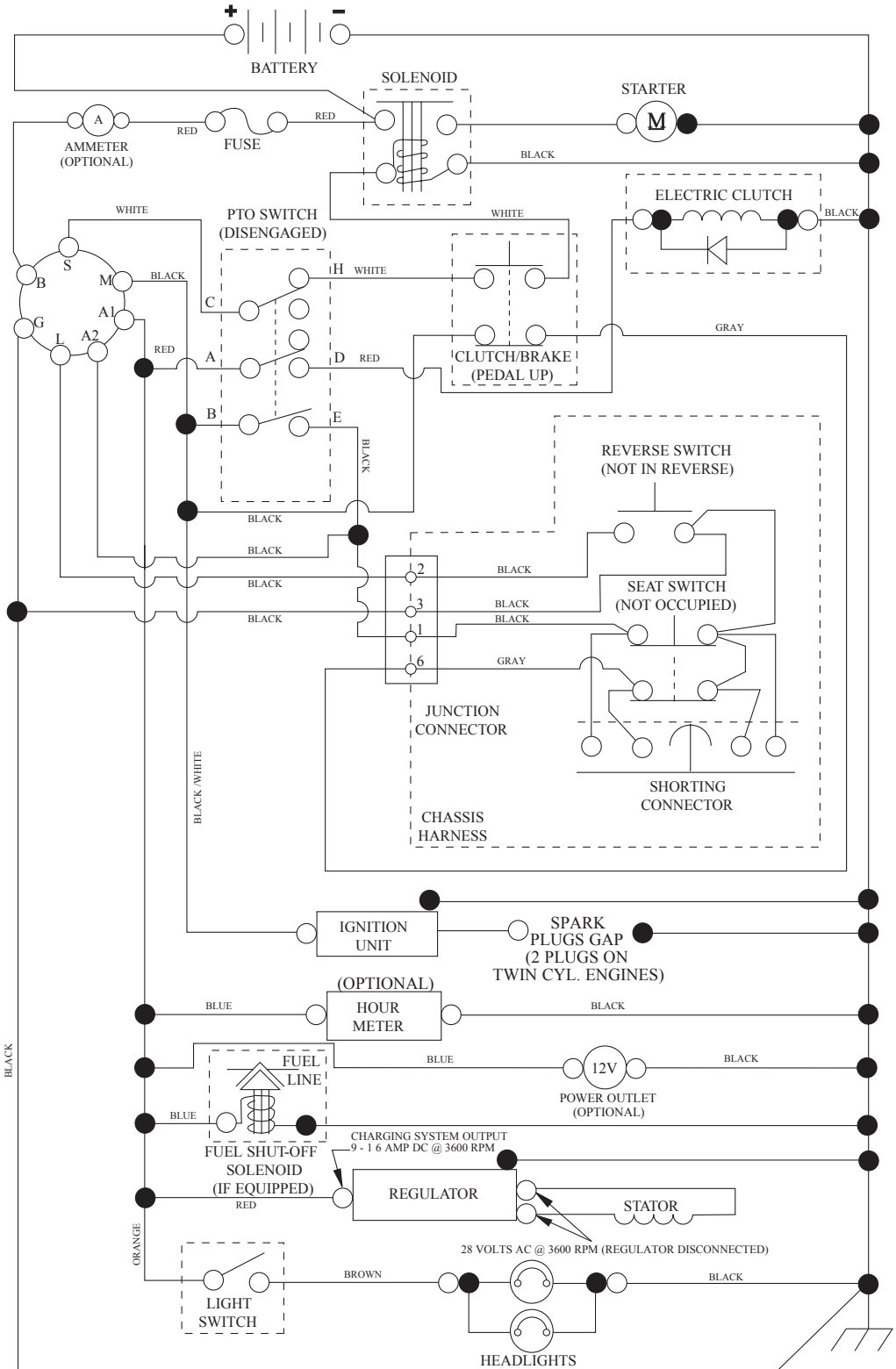

PTO SWITCH
(MATING SIDE)

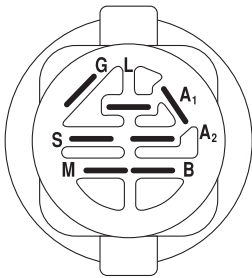

IGNITION SWITCH

POSITION	CIRCUIT	"MAKE"
OFF	M+G+A1	
RUN/OVERRIDE	B+A1	
RUN	B+A1	L+A2
START	B + S + A1	

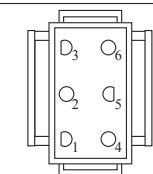

CHASSIS HARNESS
CONNECTOR
(MATING SIDE)

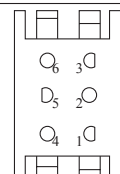

DASH HARNESS
CONNECTOR

WIRING INSULATED CLIPS
NOTE: IF WIRING INSULATED CLIPS WERE REMOVED FOR SERVICING OF UNIT, THEY SHOULD BE RE-INSTALLED TO PROPERLY SECURE YOUR WIRING.

●
NON-REMOVABLE
CONNECTIONS

○
REMOVABLE
CONNECTIONS

**TRACTOR - MODEL NO. LGT2654 (96045000702), PRODUCT NO. 960 45 00-07
ELECTRICAL**

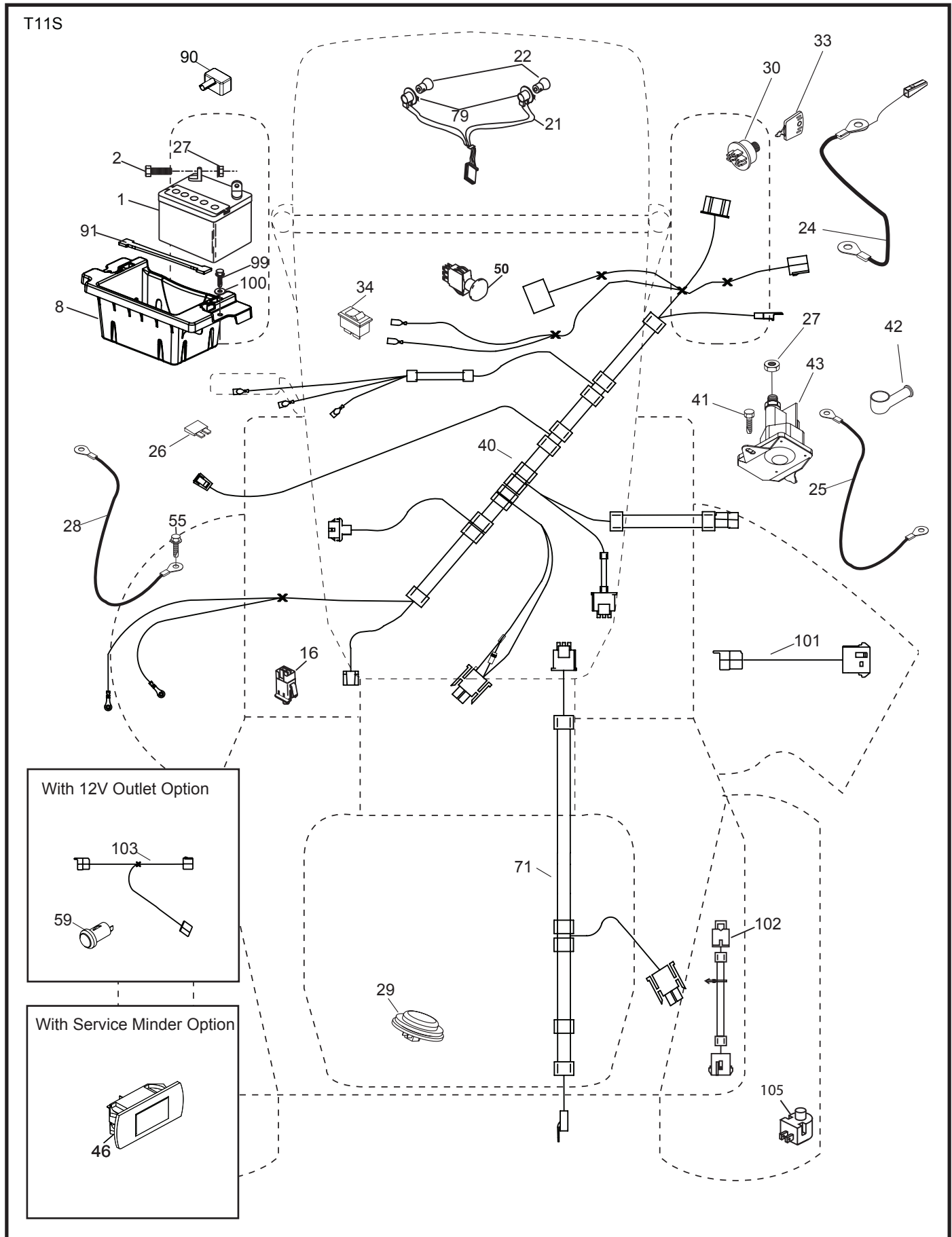

**TRACTOR - MODEL NO. LGT2654 (96045000702), PRODUCT NO. 960 45 00-07
ELECTRICAL**

KEY NO.	PART NO.	DESCRIPTION
1	532 14 49-27	Battery
2	874 76 04-12	Bolt Hex Hd 1/4-20 unc x 3/4
8	532 18 64-91	Battery Box
16	532 17 61-38	Switch Interlock
21	532 18 37-59	Harness Socket Light
22	532 00 41-52	Bulb, Light #1156
24	532 40 02-53	Cable Battery
25	532 41 28-95	Cable Starter
26	532 17 51-58	Fuse
27	873 51 04-00	Nut Keps Hex 1/4-20 unc
28	532 14 54-91	Cable Ground 21" Blk 6 Ga.
29	532 40 15-45	Switch Seat
30	532 19 33-50	Switch Ign
33	532 41 19-33	Key/Chain
34	532 11 07-12	Switch Light/Reset
40	532 40 11-04	Harness Ign. Dash
41	817 72 04-08	Screw Thd Cut 1/4-20 x 1/2
42	532 13 15-63	Cover Terminal Red
43	532 19 25-07	Solenoid
46	532 40 17-63	Gauge Hourmeter
50	532 19 61-12	Switch PTO
55	817 06 05-12	Screw Thdrol 5/16-18 x 3/4
59	532 40 03-03	Outlet 12-Volt
71	532 19 42-76	Harness Ign Chassis
79	532 17 52-42	Socket Asm Bulb
90	532 40 07-24	Cover Terminal Battery
91	532 19 02-70	Strap Battery
99	817 67 04-12	Screw Hexwsh Thdrol 1/4-20 x 3/4
100	819 09 14-16	Washer 9/32 x 7/8 x 16 Ga.
101	532 19 83-17	Pigtail
102	532 40 44-54	Harness Pigtail K46
103	532 40 79-62	Harness Pigtail 12 V Outlet
105	532 40 75-68	TT Pedal Control

NOTE: All component dimensions given in U.S. inches
1 inch = 25.4 mm

**TRACTOR - MODEL NO. LGT2654 (96045000702), PRODUCT NO. 960 45 00-07
CHASSIS**

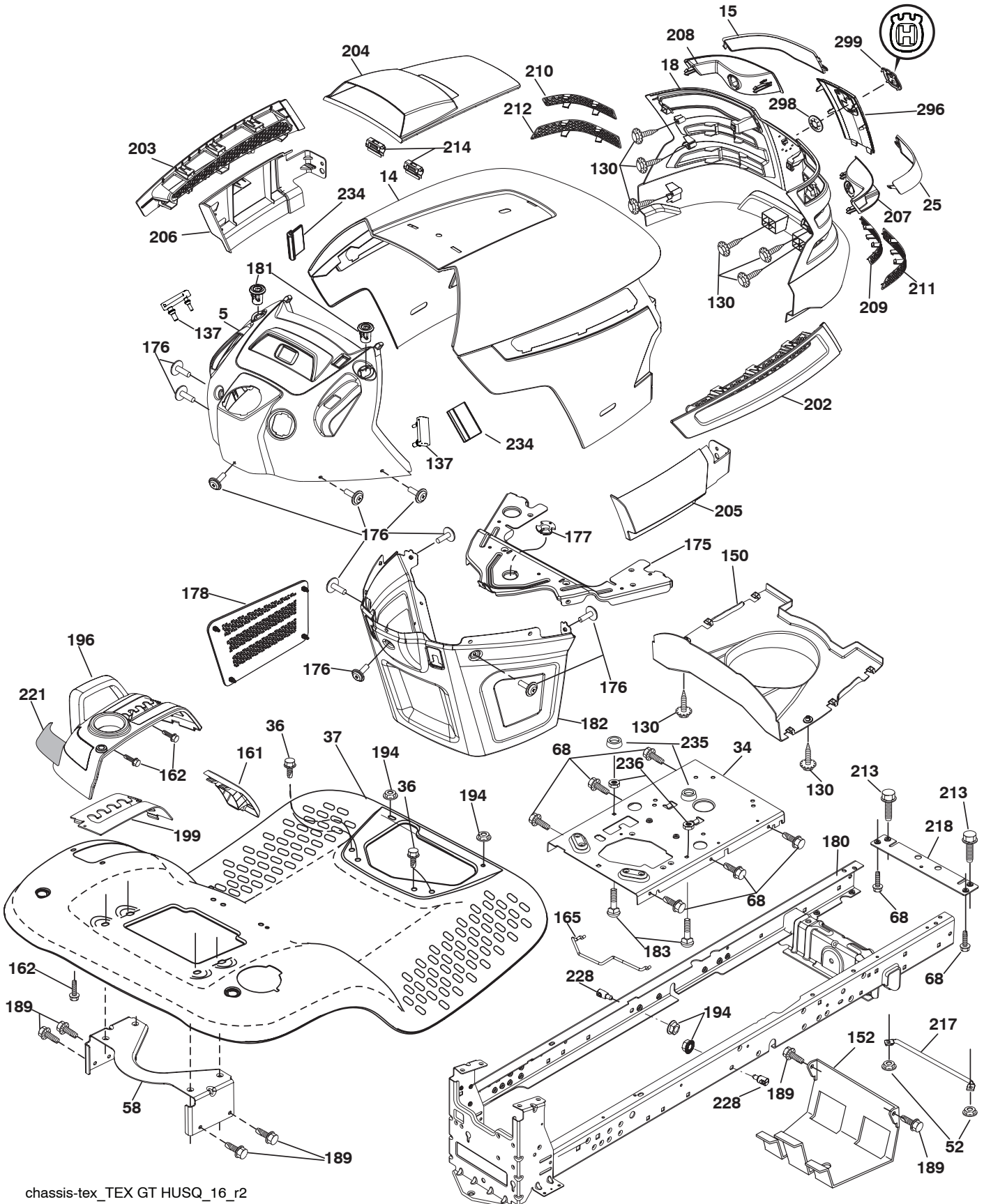

chassis-tex_TEX GT HUSQ_16_r2

**TRACTOR - MODEL NO. LGT2654 (96045000702), PRODUCT NO. 960 45 00-07
CHASSIS**

KEY NO.	PART NO.	DESCRIPTION	KEY NO.	PART NO.	DESCRIPTION
5	532 40 87-01	Dash	202	532 40 30-48	Vent Side Hood RH
14	532 41 10-46	Hood Asm.	203	532 40 30-76	Vent Side Hood LH
15	532 19 89-07	Lens LH	204	532 41 66-13	Vent Asm Hood Top
18	532 40 86-07	Grille Asm.	205	532 40 17-09	Skirt Hood Side RH
25	532 19 89-06	Lens RH	206	532 40 17-11	Skirt Hood Side LH
34	532 19 61-25	Plate Engine	207	532 19 71-98	Bezel RH
36	817 06 05-12	Screw 5/16-18 x 3/4	208	532 19 71-99	Bezel LH
37	532 40 18-25	Fender	209	532 19 91-30	Insert Hex Top RH
52	873 68 05-00	Nut Crown Lock 5/16-18	210	532 19 91-31	Insert Hex Top LH
58	532 19 43-14	Bracket Fender	211	532 19 91-32	Insert Hex Bottom RH
68	817 49 05-08	Screw 5/16-18 x 1/2	212	532 19 91-33	Insert Hex Bottom LH
130	532 41 63-58	Screw #10 x .750 BOS Thread	213	874 76 05-12	Bolt Hex Hd 5/16-18 unc x 3/4
137	532 40 75-90	Bumper Dash	214	532 19 91-45	Clip Retainer
150	532 19 85-12	Duct Heat Hood	217	532 40 91-67	Rod Pivot
152	532 19 95-35	Shield Browning/Debris	218	532 19 63-95	Hood Stop
161	532 40 18-26	Console Fuel Window	221	532 19 89-09	Reflector LH
162	532 14 24-32	Screw Hex Wsh Hi-Lo 1/4 x 1/2	228	532 19 51-61	Stud Fastener
165	532 19 68-26	Bracket Support Tank	234	532 40 47-42	Bumper Hood
175	532 19 63-04	Crossmember	235	532 40 61-29	Spacer Fender
176	532 40 07-76	Screw 10-24 x 5/8	236	873 93 05-00	Nut Center Lock 5/16-18 unc
177	532 19 52-27	Bushing Steering	296	532 40 86-06	Trim
178	532 19 97-82	Cargo Asm. Net	298	532 11 04-52	Nut Push
180	532 19 54-77	Chassis	299	532 40 50-12	Logo
181	532 40 30-25	Bushing Mtg. Fender Crgo.			
182	532 40 68-59	Dash Lower			
183	874 78 05-20	Bolt Fin Hex 5/16-18 unc x 1-1/4			
189	817 00 05-12	Screw 5/16-18 x 3/4			
194	873 80 05-00	Nut Lock Hex Flange 5/16-18			
196	532 40 02-99	Console Asm. Deck Lift			
199	532 19 82-59	Plate Deck Lift			

NOTE: All component dimensions given in U.S. inches
1 inch = 25.4 mm

**TRACTOR - MODEL NO. LGT2654 (96045000702), PRODUCT NO. 960 45 00-07
DRIVE**

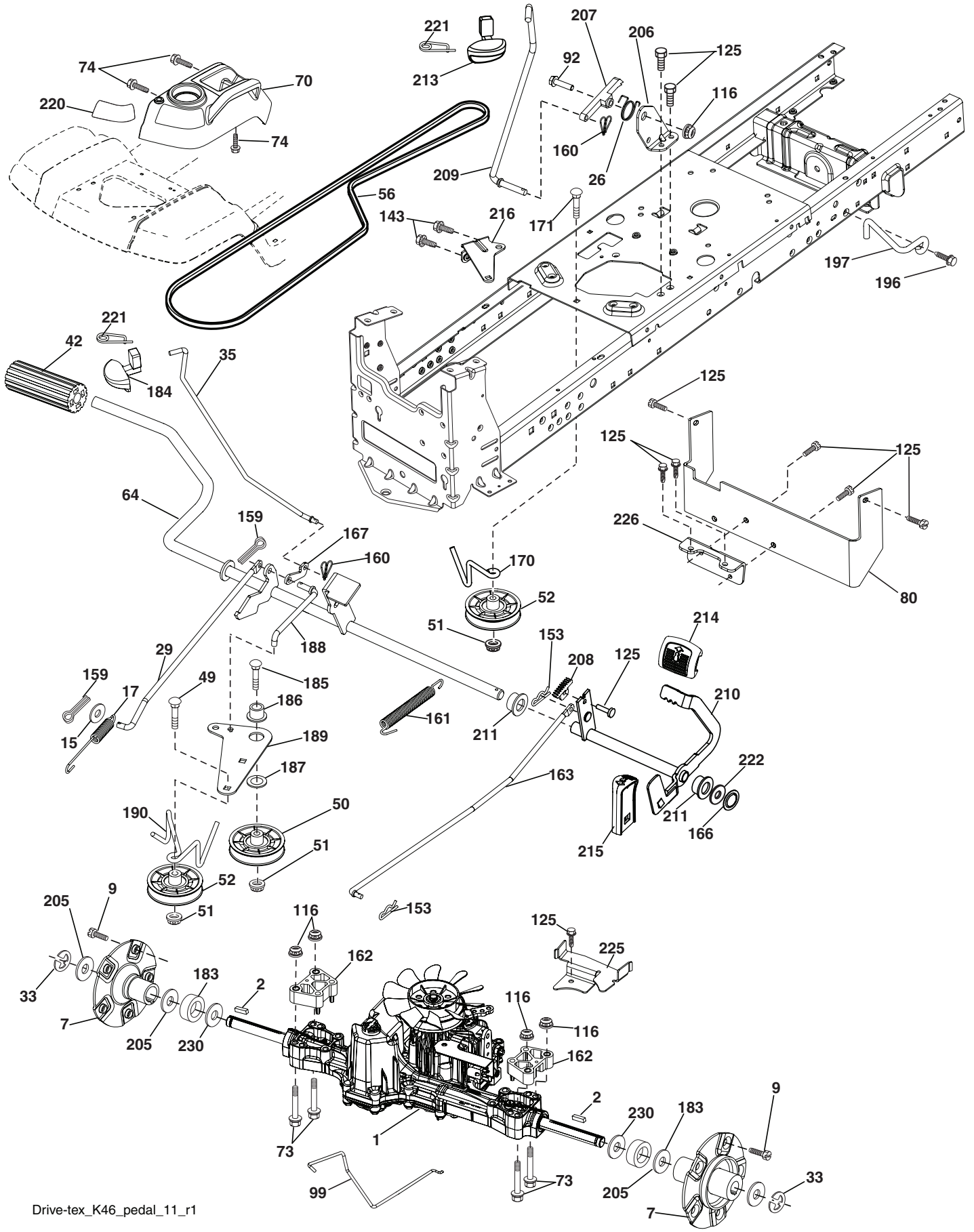

Drive-tex_K46_pedal_11_r1

**TRACTOR - MODEL NO. LGT2654 (96045000702), PRODUCT NO. 960 45 00-07
DRIVE**

KEY NO.	PART NO.	DESCRIPTION	KEY NO.	PART NO.	DESCRIPTION
1	532 41 40-06	Transaxle, TUFFTORQ K46BN	167	532 40 52-57	Latch Brake Parking
2	532 18 62-11	Key 1/4 x 2.5	170	532 19 43-22	Keeper Belt Centerspan
7	532 19 98-44	Hub Asm. Wheel	171	872 11 06-16	Bolt Rdhd Sqnk 3/8-16 unc x 2
9	532 14 00-80	Bolt Hub Wheel	183	532 40 04-24	Spacer Split
15	819 13 13-16	Washer 13/32 x 13/16 x 16 Ga.	184	532 40 31-18	Handle Parking Brake
17	532 41 36-78	Spring, Brake	185	872 11 06-20	Bolt Rdhd Sqnk 3/8-16 x 2-1/2
26	532 19 96-79	Spring Return Cruise	186	532 19 43-21	Spacer Retainer
29	532 40 38-06	Rod, Brake	187	819 13 32-10	Washer
33	812 00 00-01	Ring E	188	532 19 43-23	Link Clutch Ground Drive
35	532 19 95-91	Rod, Brake, Park	189	532 19 43-17	Bellcrank Ground Drive
42	532 12 48-72	Cover, Foot Pedal	190	532 19 43-18	Keeper Bellcrank Ground Drive
49	872 11 06-14	Bolt	196	817 00 06-16	Screw 3/8-16 x 1
50	532 19 43-27	Pulley Idler Flat	197	532 19 97-69	Bracket Clutch Anti-Rotation
51	873 90 06-00	Lock Nut 3/8-16	205	532 12 17-48	Washer
52	532 19 43-26	Idler V-Groove 910" Offset	206	532 19 78-67	Bracket Mount Latch Cruise
56	532 13 09-69	V-Belt, Drive	207	532 19 78-68	Latch Control Cruise
64	532 19 78-65	Shaft Asm. Pedal Brake Control	208	532 19 78-69	Gear Sector Control Cruise
70	532 40 05-30	Control Asm.	209	532 19 95-92	Rod Control Cruise
73	874 49 05-60	Bolt Hex Flghd 5/16-18 x 3.75	210	532 19 78-60	Rocker Asm. Pedal Control
74	532 14 24-32	Screw 1/4 x 1/2	211	532 12 01-83	Bearing Nylon
80	532 41 33-05	Bracket Strap Torque	213	532 40 31-19	Knob Control Cruise
92	874 76 05-20	Bolt Fin Hex 5/16-18 unc x 1.25	214	532 40 17-22	Pedal Forward
99	532 41 57-43	Rod Spring Bypass	215	532 40 17-23	Pedal Reverse
116	873 90 05-00	Nut Lock Hex Flange 5/16-18	216	532 19 61-31	Bracket Pulley Idler
125	817 00 05-12	Screw 5/16-18 x 3/4	220	532 19 89-08	Reflector RH
143	817 49 05-08	Screw Thdrol 5/16-18 x 1/2	221	532 40 31-87	Retainer Spring Clip Handle
153	532 12 47-88	Retainer Spring	222	819 21 20-10	Washer 21/32 x 1-1/4 x 10 Ga.
159	876 02 04-12	Pin Cotter 1/8 x 3/4	225	532 40 33-19	Keeper Belt Trans.
160	532 16 94-84	Retainer Clip	226	532 40 08-31	Bracket Mount Touque
161	532 10 57-09	Spring, Return, Clutch	230	532 18 89-67	Washer Harden
162	532 19 57-85	Spacer Transaxle			
163	532 40 10-34	Rod Pedal Control			
166	532 19 72-90	Nut Push .625			

NOTE: All component dimensions given in U.S. inches
1 inch = 25.4 mm

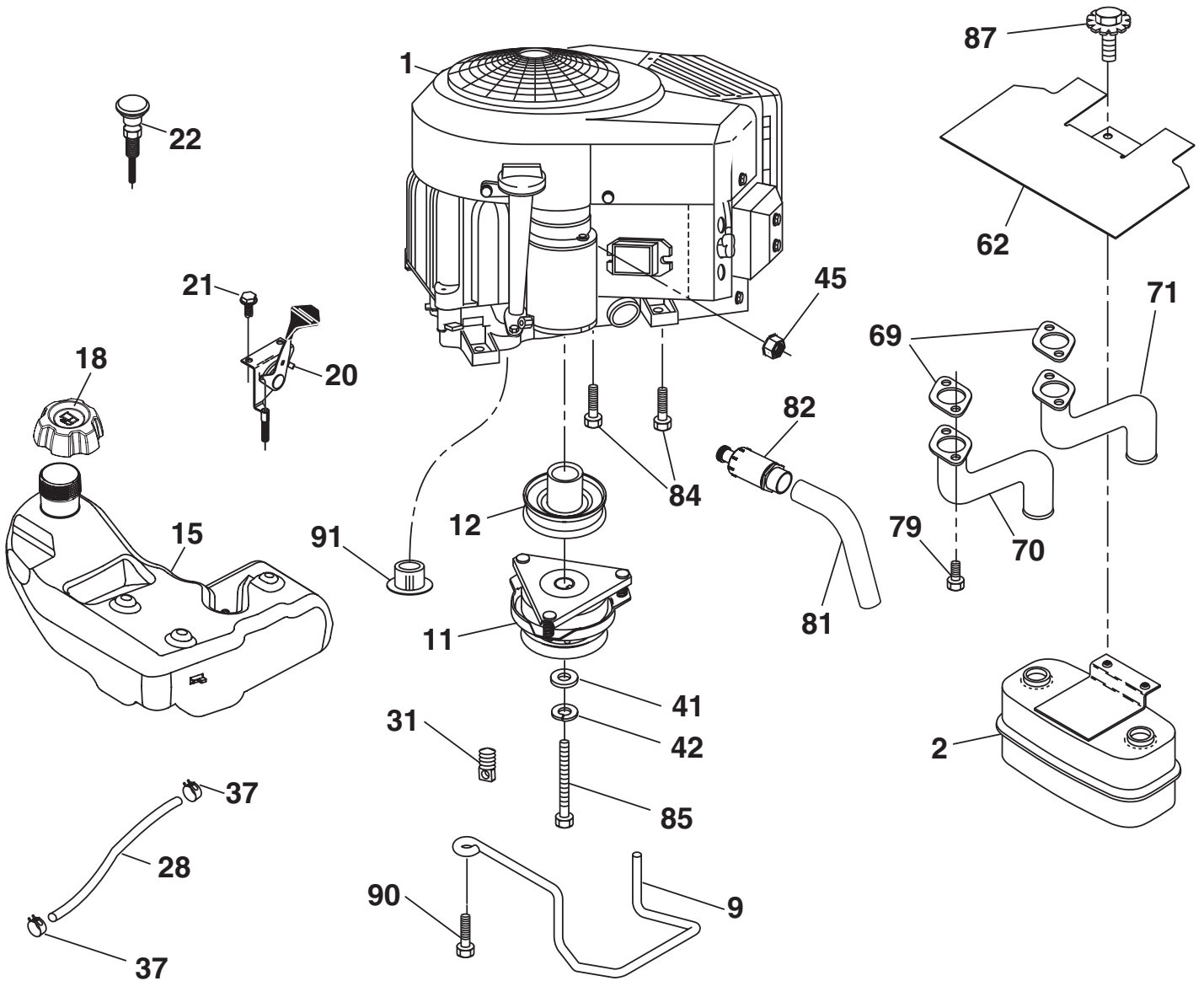

SPARK ARRESTER KIT

engine-tex_bs-2cyl_9

TRACTOR - MODEL NO. LGT2654 (96045000702), PRODUCT NO. 960 45 00-07 ENGINE

KEY NO.	PART NO.	DESCRIPTION
1	-----	Engine Briggs Model No. 44P777
2	532 14 97-23	Muffler
9	532 19 43-20	Keeper Belt Engine
11	532 17 93-35	Clutch Electric
12	532 19 43-43	Pulley Engine
15	532 19 34-99	Tank Fuel 4.0
18	532 19 42-67	Cap Asm
20	532 17 83-85	Control Throttle
21	532 41 63-58	Screw #10 x .750 BOS Thread
22	532 19 15-96	Control Choke
28	532 40 11-35	Fuel Line
29	532 13 71-80	Spark Arrester Kit
31	532 14 50-06	Clip Push-In
37	532 12 34-87	Clamp Hose
41	532 12 61-97	Washer 1-1/2 OD x 15/32 ID x .250
42	810 04 07-00	Washer Lock 7/16
45	873 51 04-00	Nut Keps Hex 1/4-20 unc
62	532 14 66-29	Shield Heat Muffler
69	532 16 53-91	Gasket
70	532 15 99-55	Tube Exhaust LH
71	532 16 05-89	Tube Exhaust RH
79	532 18 39-06	Screw Socket Head 5/16-18 x 1
81	532 14 84-56	Tube Drain Oil Easy
82	532 18 16-54	Plug Drain Oil
84	817 06 06-20	Screw 3/8-16 x 1 1/4
85	532 17 99-53	Bolt Hex 7/16-20 x 3.75 Gr. 5
87	532 19 82-39	Bolt 5/16-18 unc x 1 w/Sems
90	817 00 06-16	Screw 3/8-16 x 1
91	532 18 74-95	Bushing

NOTE: All component dimensions given in U.S. inches
1 inch = 25.4 mm

For engine service and replacement parts, call the toll free number for your engine manufacturer listed below:

Briggs & Stratton 1-800-233-3723

Engine Power Rating Information

The gross power rating for individual gas engine models is labeled in accordance with SAE (Society of Automotive Engineers) code J11940 (Small Engine Power & Torque Rating Procedure), and rating performance has been obtained and corrected in accordance with SAE J1995 (Revision 2002-5). Actual gross engine power will be lower and is affected by, among other things, ambient operating conditions and engine-to-engine variability. Given both the wide array of products on which engines are placed and the variety of environmental issues applicable to operating the equipment, the gas engine will not develop the rated gross power when used in a given piece of power equipment (actual "on-site" or net horsepower). This difference is due to a variety of factors including, but not limited to, accessories (air cleaner, exhaust, charging, cooling, carburetor, fuel pump, etc.), application limitations, ambient operating conditions (temperature, humidity, altitude), and engine-to-engine variability. Due to manufacturing and capacity limitations, Briggs & Stratton may substitute an engine of higher rated power for this Series engine.

**TRACTOR - MODEL NO. LGT2654 (96045000702), PRODUCT NO. 960 45 00-07
STEERING ASSEMBLY**

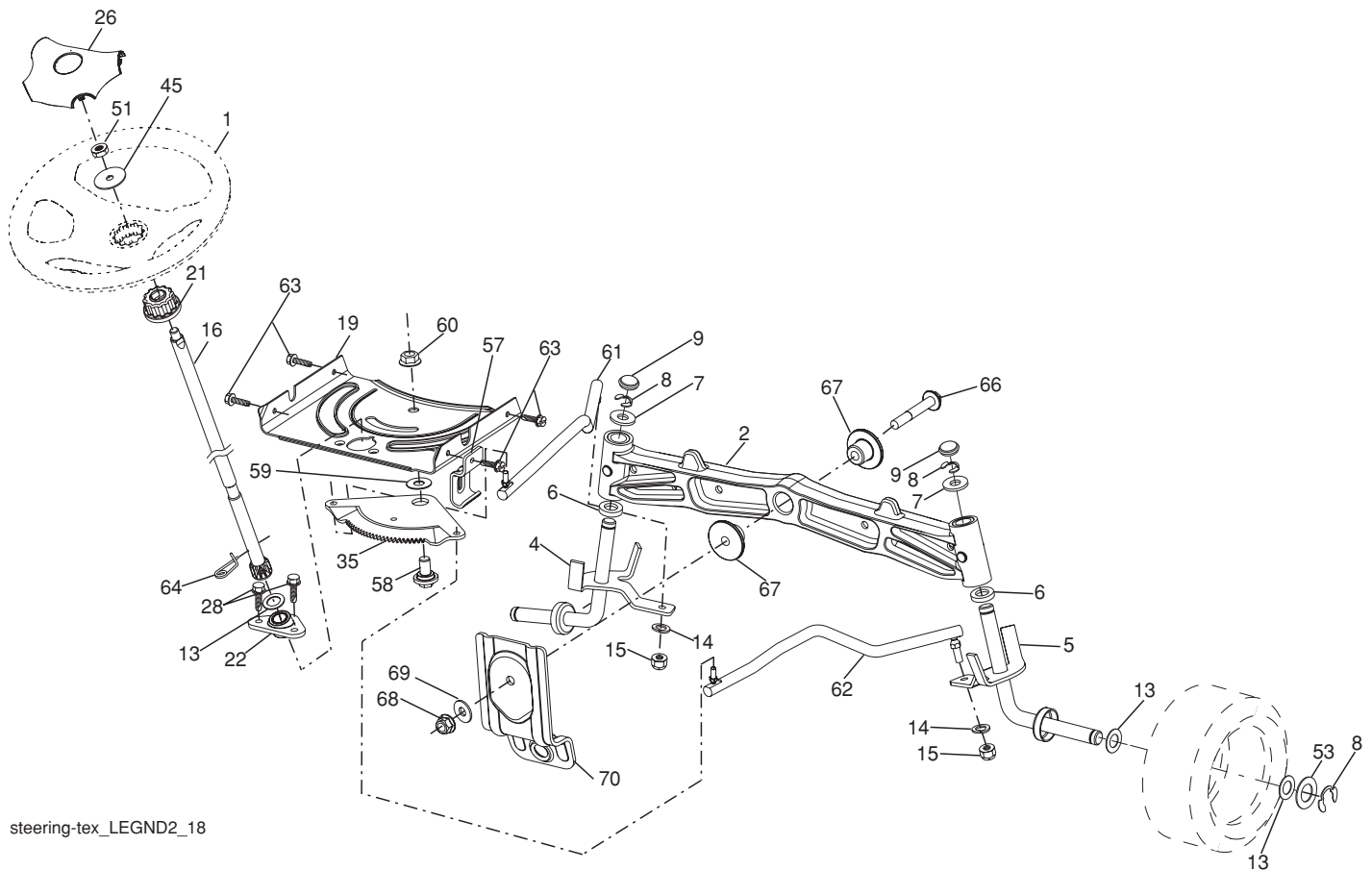

steering-tex_LEGND2_18

KEY NO.	PART NO.	DESCRIPTION	KEY NO.	PART NO.	DESCRIPTION
1	532 19 39-43	Wheel, Steering	51	873 94 08-00	Nut Hex Jam Toplock 1/2-20 unf
2	532 19 59-68	Axle Asm., Front	53	532 18 89-67	WasherHardened.793x1.637x.060
4	532 40 30-89	Spindle Asm., LH	57	532 19 72-46	Bracket Upstop
5	532 40 30-90	Spindle Asm., RH	58	532 19 47-47	Bolt Shoulder Sector Pivot CFM
6	532 12 49-31	Bearing, Race Thrust Harden	59	532 19 47-48	Washer Thrust Sector Steering
7	532 12 17-48	Washer 25/32 x 1-5/8 x 16 Ga.	60	873 97 10-00	Nut Flange Lock 5/8-11
8	812 00 00-29	Ring, Clip #T5304-75	61	532 19 47-40	Draglink, LH
9	532 12 12-32	Cap, Spindle	62	532 19 47-41	Draglink, RH
13	532 12 17-49	Washer 25/32 x 1-1/4 x 16 Ga.	63	817 00 05-12	Screw 5/16-18 x 3/4
14	810 04 06-00	Washer, Lock Hvy Hlcl Spr 3/8	64	532 19 98-49	Retainer Clip Spring Steering
15	873 54 06-00	Nut, Crown Lock 3/8-24 unf	66	871 02 07-48	Bolt Hex Fghd 7/16-14 x 3 Serr
16	532 40 82-19	Shaft Steering	67	532 19 47-37	Bushing PM Front Axle
19	532 19 47-29	Plate Steering	68	873 90 07-00	Nut Lock Flange 7/16-14 Gr. 5
21	532 18 67-37	Adapter, Wheel Steering	69	532 19 91-62	Washer 1.5 x .505 x .118
22	532 19 48-45	Bushing, Strg. Blk	70	532 19 61-97	Bracket Deck Susp. Front
26	532 19 36-52	Insert, Wheel Steering			
28	817 00 06-12	Screw 3/8-16 x 3/4			
35	532 19 47-32	Gear, Sector Plate			
45	819 18 38-12	Washer 9/16 x 2-3/8 x 12 Ga.			

NOTE: All component dimensions given in U.S. inches
1 inch = 25.4 mm

**TRACTOR - MODEL NO. LGT2654 (96045000702), PRODUCT NO. 960 45 00-07
SEAT ASSEMBLY**

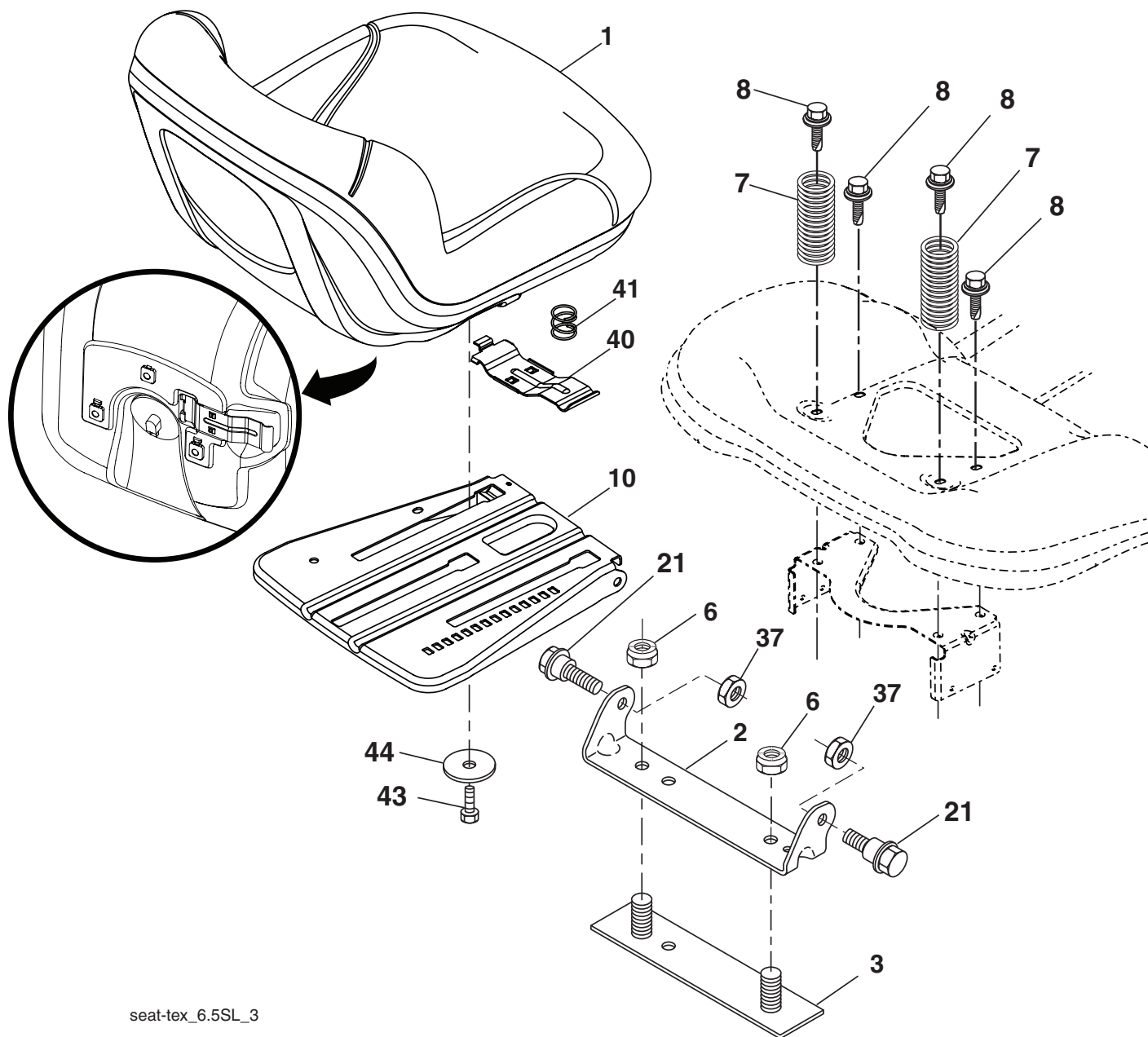

seat-tex_6.5SL_3

KEY NO.	PART NO.	DESCRIPTION
1	532 40 66-21	Seat
2	532 18 01-66	Bracket Pivot Fender
3	532 14 06-75	Strap, Asm Fender
6	873 80 06-00	Nut, Lock w/Ins. 3/8-16 unc
7	532 12 41-81	Spring, Seat Cprsn
8	532 17 18-77	Bolt 5/16-18 unc x 3/4 w/Sems
10	532 19 69-77	Pan, Seat
21	532 17 18-52	Bolt, Shoulder 5/16-18

KEY NO.	PART NO.	DESCRIPTION
37	873 80 05-00	Nut, Lock 5/16-18 unc
40	532 19 76-61	Handle Slide Seat
41	532 19 82-00	Spring Latch Seat
43	874 76 06-12	Bolt 3/8-16 x 3/4
44	819 13 38-12	Washer 13/32 x 2-3/8 x 12 Ga.

NOTE: All component dimensions given in U.S. inches
1 inch = 25.4 mm

**TRACTOR - MODEL NO. LGT2654 (96045000702), PRODUCT NO. 960 45 00-07
MOWER DECK**

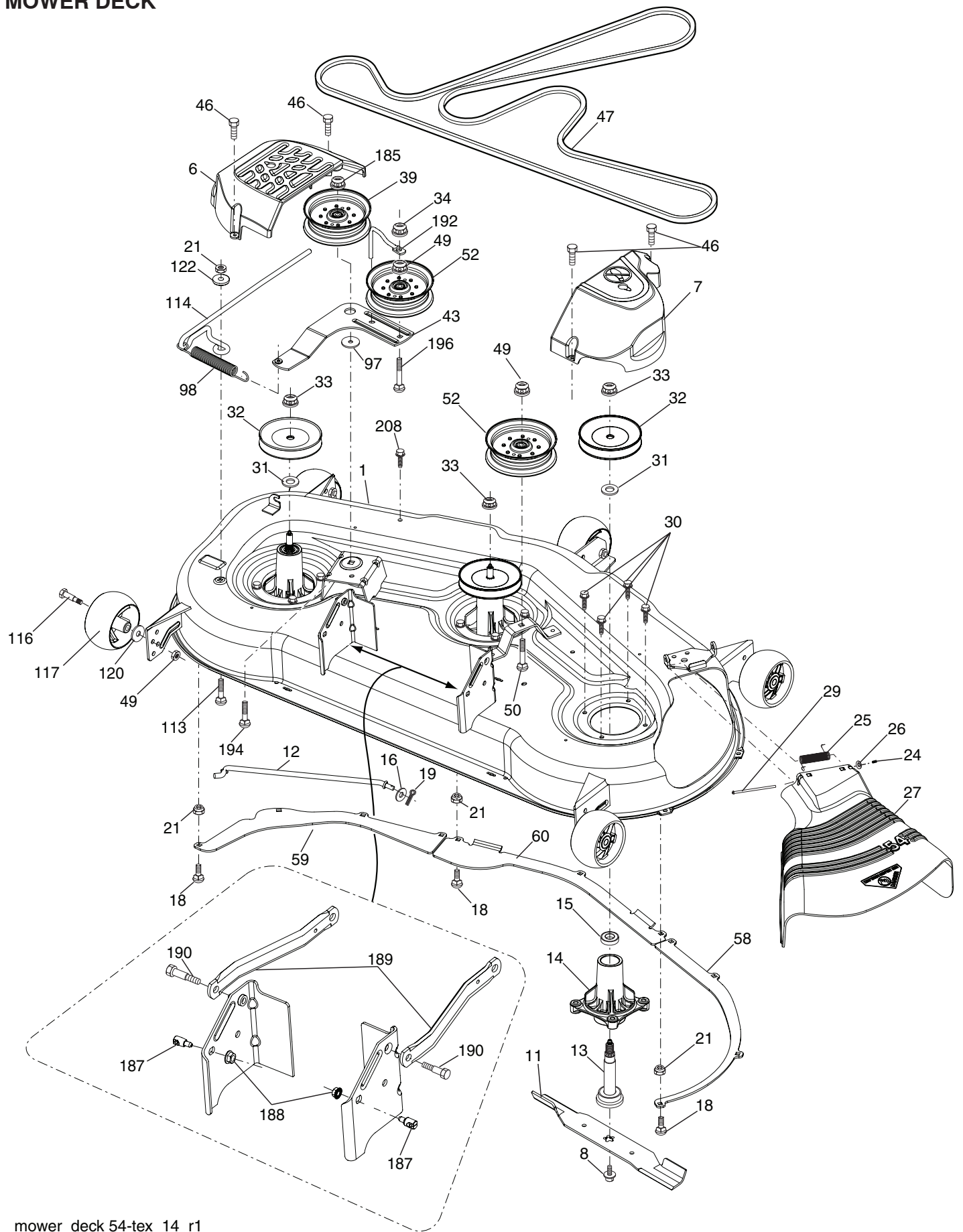

mower_deck 54-tex_14_r1

**TRACTOR - MODEL NO. LGT2654 (96045000702), PRODUCT NO. 960 45 00-07
MOWER DECK**

KEY NO.	PART NO.	DESCRIPTION	KEY NO.	PART NO.	DESCRIPTION
1	532 40 31-25	Deck Weldment Mower	50	872 11 06-16	Bolt Rdhd Sqnk 3/8-16 unc x 2
6	532 19 60-66	Cover Mandrel LH	52	532 19 73-79	Pulley Idler
7	532 19 71-81	Cover Mandrel RH	58	532 18 73-42	Baffle Right
8	532 17 43-65	Bolt 7/16 Asm. Blade	59	532 18 73-44	Baffle Left
11	532 18 72-56	Blade Bagging	60	532 18 76-07	Baffle Center
-	532 18 72-55	Blade Mulching	97	532 17 85-15	Washer Hardened
12	532 40 48-51	Rod Anti Sway	98	532 19 61-05	Spring Drive
13	532 18 72-91	Shaft Asm. w/Lower Bearing	113	872 11 05-08	Bolt Rdhd Sqnk 5/16-18 x 3/4
14	532 18 72-81	Housing, Mandrel	114	532 18 75-56	Rod Tension Relief
16	819 13 13-12	Washer 3/8	116	532 19 34-06	Bolt, Shoulder
15	532 11 04-85	Bearing, Ball, Mandrel	117	532 17 48-73	Gauge Wheel
18	872 14 05-05	Bolt Carriage 5/16-18 x 5/8	120	819 13 20-12	Washer 13/32 x 1-1/4 x 12 Ga.
19	532 19 42-08	Pin Cotter 5/16 Bowtie	122	532 18 75-57	Bushing Tension Relief
21	873 68 05-00	Nut, Crownlock 5/16-18 unc	185	873 90 07-00	Nut Lock Flange 7/16-14 Gr. 5
24	532 10 53-04	Cap Sleeve	187	532 19 51-61	Stud Fastener w/"D" Anti-Rotation
25	532 17 81-02	Spring, Torsion	188	873 90 05-00	Nut Lock Hex Flange
26	532 11 04-52	Nut, Push	189	532 19 51-85	Arm Susp. Mower Rear
27	532 18 89-38	Deflector Shield	190	532 19 65-39	Bolt Shoulder
29	532 13 14-91	Rod, Hinge	192	532 19 84-68	Keeper Belt Idler
30	532 17 39-84	Screw, Thdroll Washer Head	194	872 14 07-16	Bolt Carr Sqnk 7/16-24 x 2
31	532 18 76-90	Washer, Spacer Mower Vented	196	872 14 06-20	Bolt Rdhd 3/8-16 x 2-1/2 Gr. 5
32	532 15 35-35	Pulley, Mandrel	208	817 67 06-08	Screw Thdrol 3/8-16 x 1 1/2
33	532 40 02-34	Nut, Flg. Top Lock	- -	532 18 72-92	Mandrel Asm. Service (Includes Key Nos. 13-15 and 33)
34	873 68 06-00	Nut Crownlock 3/8-16 unc	- -	532 19 93-00	Replacement Mower, Complete
39	532 19 73-80	Pulley, Idler, Stationary LH			
43	532 19 60-65	Arm, Idler			
46	532 13 77-29	Screw, Thdroll. 1/4-20 x 5/8			
47	532 19 61-03	Belt Deck Drive			
49	873 90 06-00	Nut, Lock Flg. 3/8-16 unc			

NOTE: All component dimensions given in U.S. inches
1 inch = 25.4 mm

**TRACTOR - MODEL NO. LGT2654 (96045000702), PRODUCT NO. 960 45 00-07
MOWER LIFT**

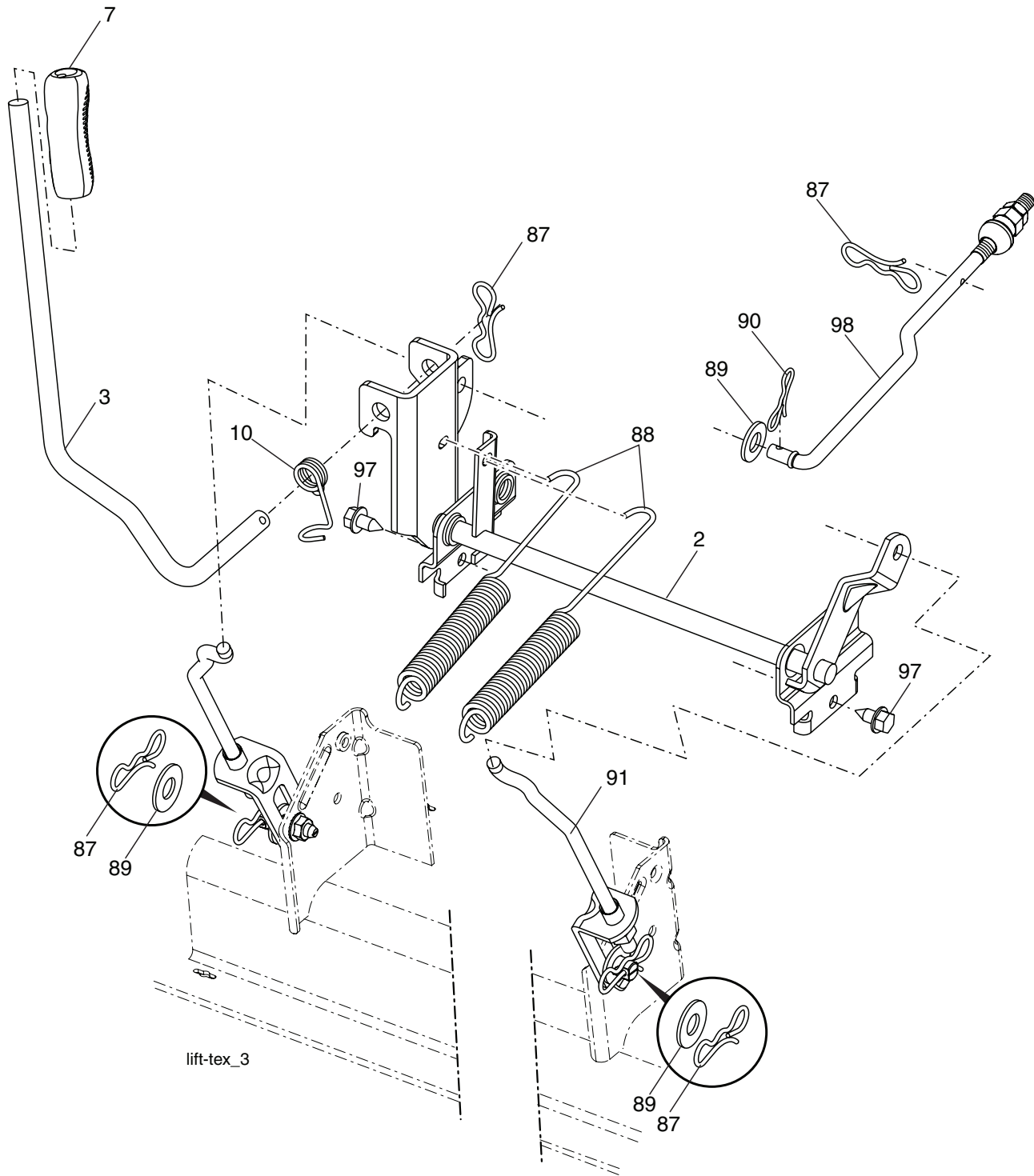

KEY NO.	PART NO.	DESCRIPTION
2	532 19 52-23	Shaft Asm., Lift
3	532 19 52-30	Lever Asm., Lift RH
7	532 41 15-55	Grip, Lever
10	532 19 63-14	Spring Torsion
87	532 19 42-09	Pin Cotter 7/16 Bow Tie Lock
88	532 19 53-04	Spring Lift Assist
89	819 19 19-12	Washer Clear Zinc

KEY NO.	PART NO.	DESCRIPTION
90	532 19 42-08	Pin Cotter 5/16 Bow Tie Lock
91	532 40 34-07	Link Lift Susp Mower Rear
97	817 00 06-12	Screw 3/8-16 x 3/4
98	532 19 52-64	Link Lift Susp. Front Mower

NOTE: All component dimensions given in U.S. inches
1 inch = 25.4 mm