



YTH20K46

Illustrated Parts List / 96045000407 / 2008-07

TRACTOR - - MODEL NUMBER YTH20K46 (96045000407), PRODUCT NO. 960 45 00-04 SCHEMATIC

SCH10

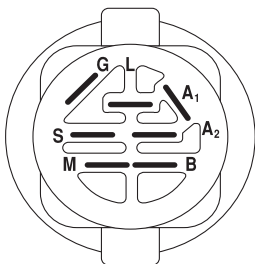
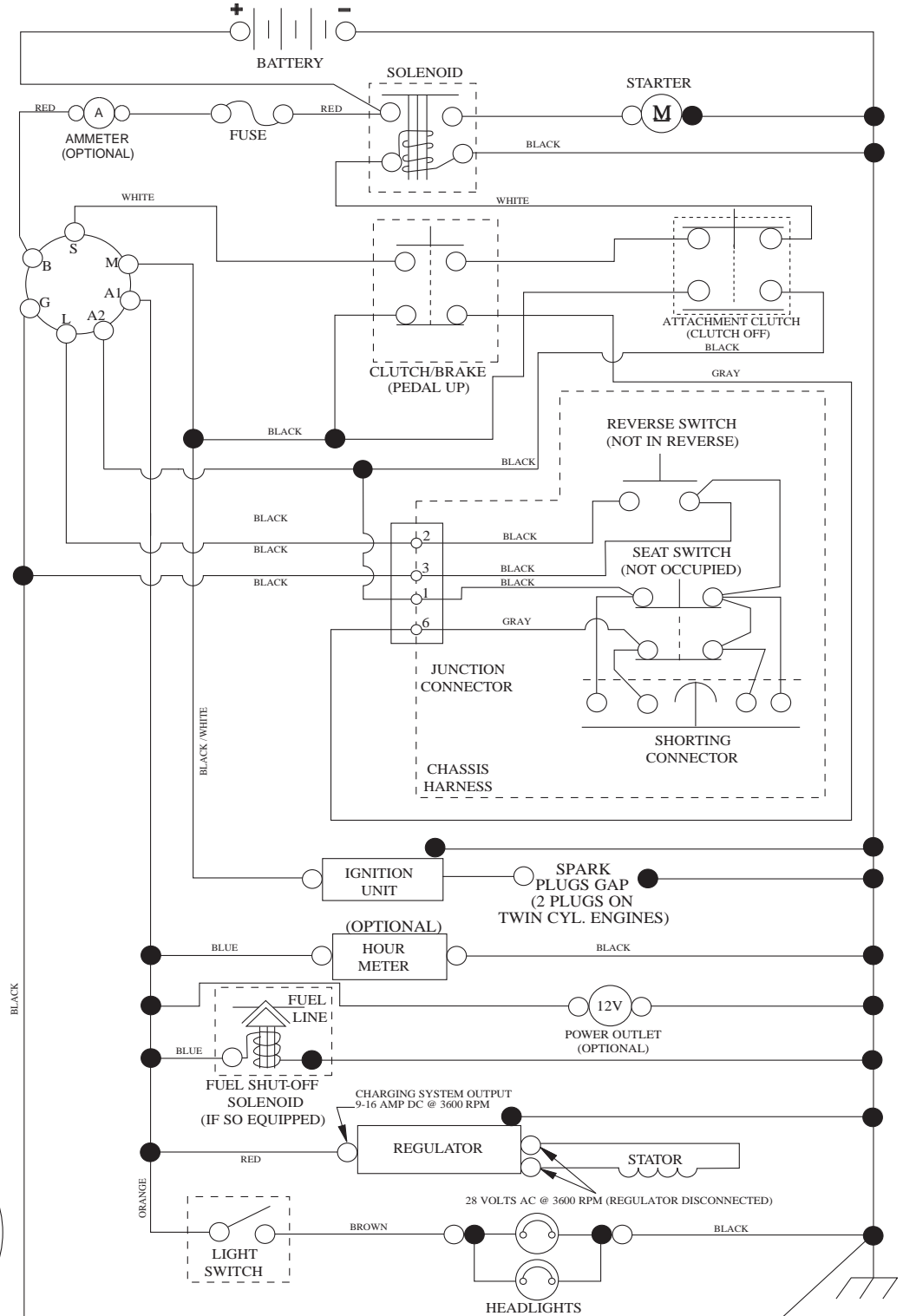

IGNITION SWITCH

POSITION	CIRCUIT	"MAKE"
OFF	M+G+A1	
RUN/OVERRIDE	B+A1	
RUN	B+A1	L+A2
START	B + S + A1	

03107

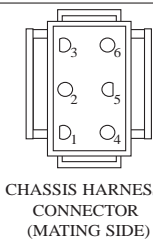

CHASSIS HARNESS CONNECTOR (MATING SIDE)

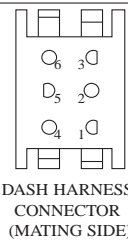

DASH HARNESS CONNECTOR (MATING SIDE)

WIRING INSULATED CLIPS
NOTE: IF WIRING INSULATED CLIPS WERE REMOVED FOR SERVICING OF UNIT, THEY SHOULD BE RE-INSTALLED TO PROPERLY SECURE YOUR WIRING.

●
NON-REMOVABLE CONNECTIONS

○
REMOVABLE CONNECTIONS

**TRACTOR - - MODEL NUMBER YTH20K46 (96045000407), PRODUCT NO. 960 45 00-04
ELECTRICAL**

T04S

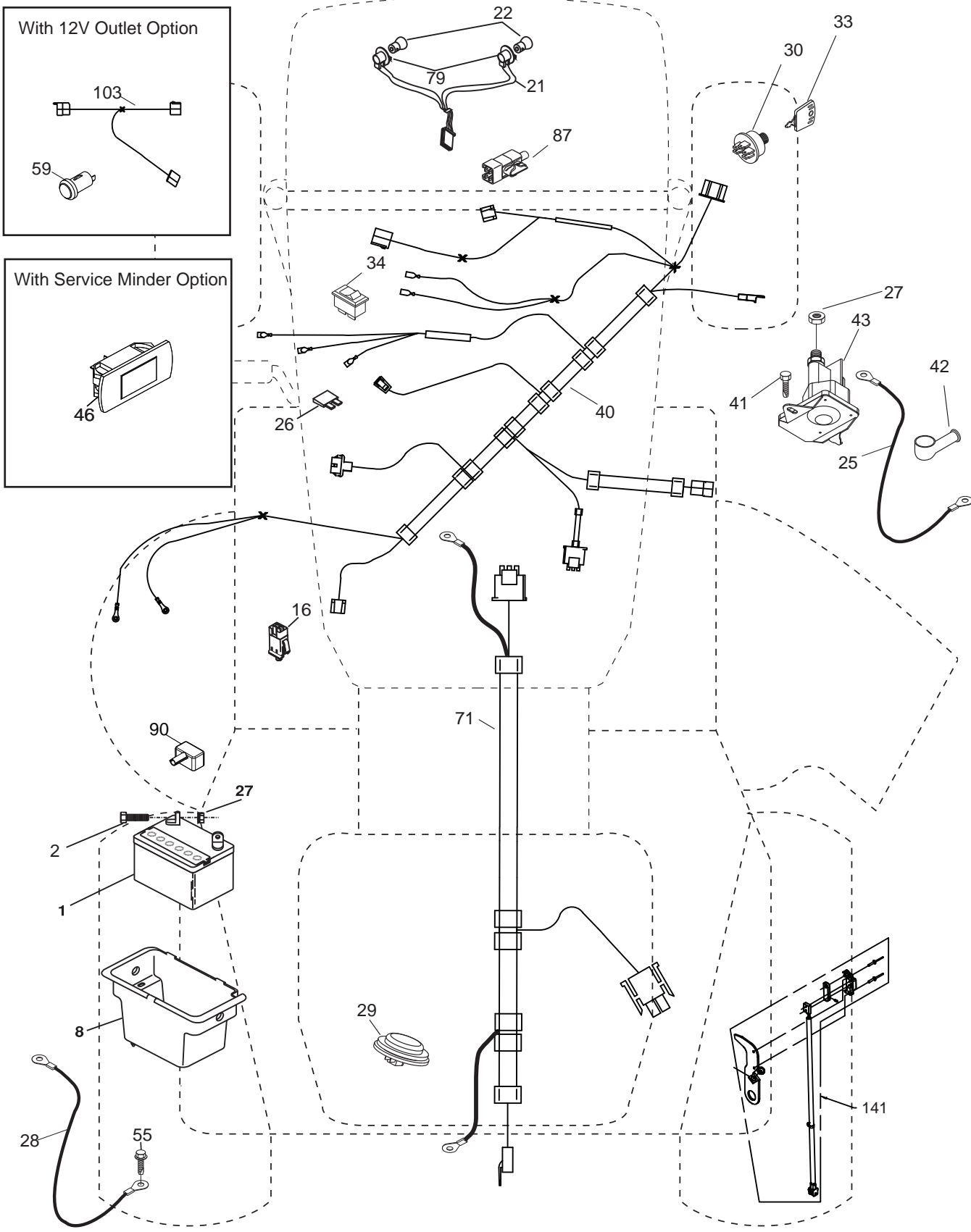
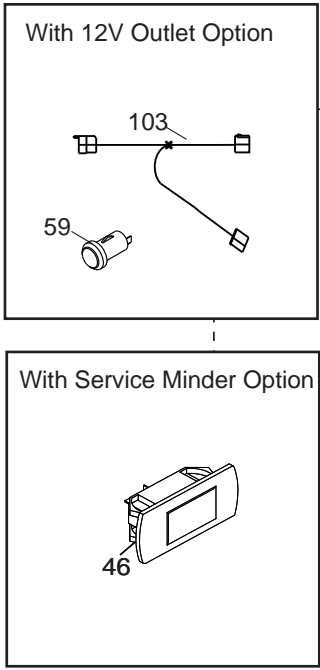

**TRACTOR - - MODEL NUMBER YTH20K46 (96045000407), PRODUCT NO. 960 45 00-04
ELECTRICAL**

KEY NO.	PART NO.	DESCRIPTION
1	532 16 34-65	Battery
2	874 76 04-12	Bolt Hex Head 1/4-20 x 3/4
8	532 19 32-28	Box Battery
16	532 17 61-38	Switch Interlock Push-In
21	532 18 37-59	Harness Socket Light W/4152J
22	532 00 41-52	Bulb Light
25	532 41 28-95	Cable Starter
26	532 17 51-58	Fuse
27	873 51 04-00	Nut Keps Hex 1/4-20 unc
28	532 19 88-85	Cable, Ground
29	532 40 15-45	Switch, Seat
30	532 19 33-50	Switch, Ign
33	532 41 19-33	Key/Chain
34	532 11 07-12	Switch Light / Reset
40	532 40 10-98	Harness Ign. Dash
41	817 72 04-08	Screw Thd Cut 1/4-20 x 1/2
42	532 13 15-63	Cover, Terminal
43	532 19 25-07	Solenoid
46	532 40 17-63	Gauge Servicere minder Hrmtr
55	817 06 05-12	Screw Thdrol 5/16-18 x 3/4 TYTT
71	532 40 04-49	Harness Ign.
79	532 17 52-42	Socket Asm. Bulb
87	532 19 78-02	Switch
90	532 40 07-25	Cover Terminal
141	532 41 69-77	Kit T2 ROS

NOTE: All component dimensions given in U.S. inches
1 inch = 25.4 mm

**TRACTOR - - MODEL NUMBER YTH20K46 (96045000407), PRODUCT NO. 960 45 00-04
CHASSIS**

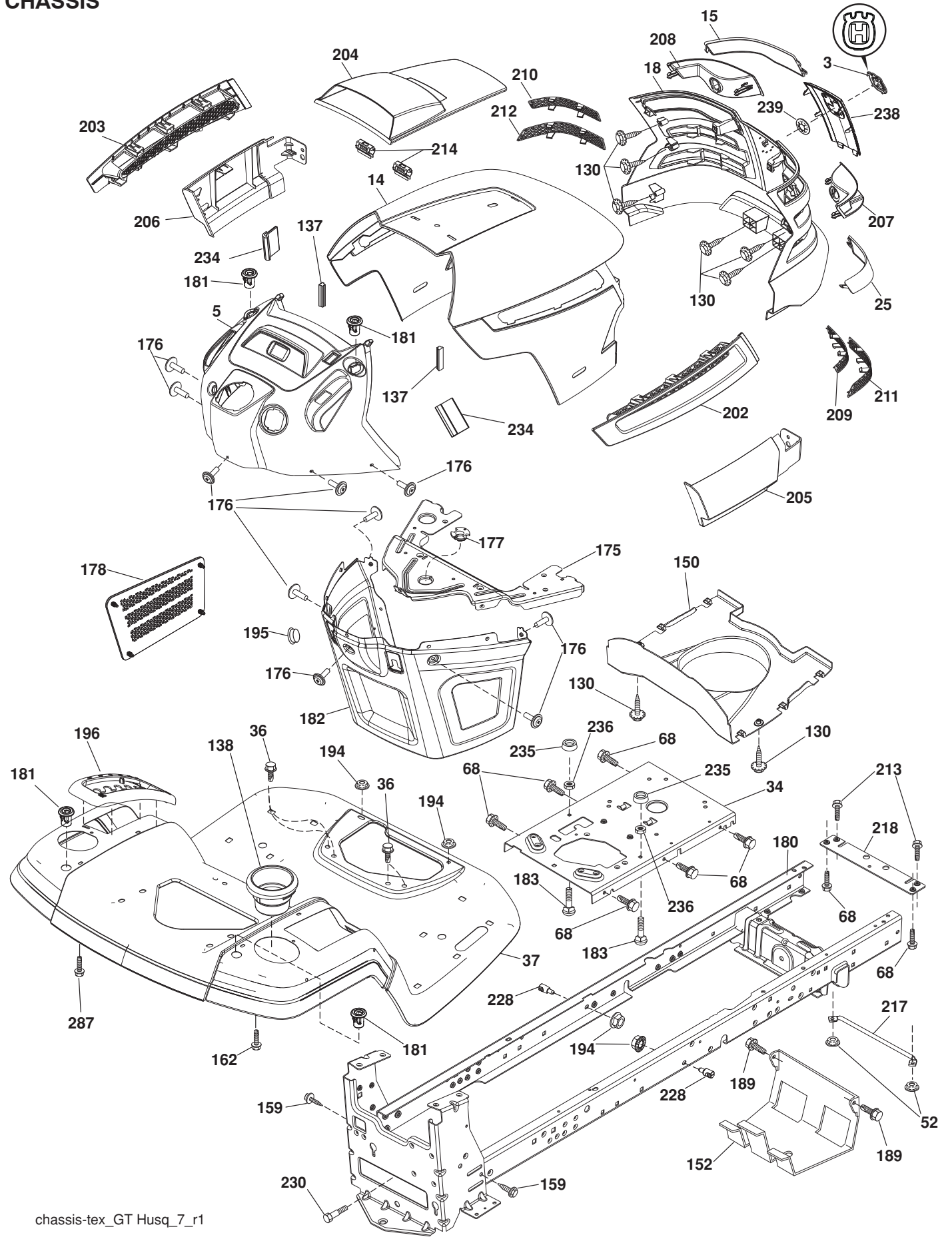

chassis-tex_GT Husq_7_r1

TRACTOR - - MODEL NUMBER YTH20K46 (96045000407), PRODUCT NO. 960 45 00-04 CHASSIS

KEY NO.	PART NO.	DESCRIPTION	KEY NO.	PART NO.	DESCRIPTION
3	532 40 50-12	Logo	196	532 41 45-80	Console Asm. Deck Lift
5	532 40 87-03	Dash	202	532 40 30-48	Vent Side Hood RH
14	532 41 10-46	Hood	203	532 40 30-76	Vent Side Hood LH
15	532 19 89-07	Lens LH	204	532 41 66-13	Vent Top Hood
18	532 40 86-07	Grille/Lens Asm.	205	532 40 17-09	Skirt Hood Side RH
25	532 19 89-06	Lens RH	206	532 40 17-11	Skirt Hood Side LH
34	532 19 61-25	Plate Engine	207	532 19 71-98	Bezel RH
36	817 06 05-12	Screw 5/16-18 x 3/4	208	532 19 71-99	Bezel LH
37	532 41 87-14	Fender	209	532 19 91-30	Insert Hex Top RH
52	873 68 05-00	Nut Lock 5/16-18	210	532 19 91-31	Insert Hex Top LH
68	817 49 05-08	Screw Thdrol 5/16-18 x 1/2	211	532 19 91-32	Insert Hex Bottom RH
130	532 41 63-58	Screw #10 x 0.750	212	532 19 91-33	Insert Hex Bottom LH
137	532 40 75-90	Bumper Dash	213	874 76 05-12	Bolt 5/16-18 x 3/4
138	532 40 29-54	Cupholder	214	532 19 91-45	Clip Retainer Tinner
150	532 19 85-13	Air Duct	217	532 40 91-67	Rod Pivot
152	532 19 95-35	Shield Browning	218	532 19 63-95	X-Piece Hood Stop
159	817 00 06-12	Screw 3/8-16 x 3/4	228	532 19 51-61	Stud Fastner
162	532 14 24-32	Screw	230	532 17 01-65	Bolt Shoulder 5/16-18
175	532 19 63-04	Crossmember	234	532 40 47-42	Bumper Hood
176	532 40 07-76	Screw 10-24 x 5/8	235	532 40 61-29	Spacer Fender
177	532 19 52-27	Bushing Steering	236	873 93 05-00	Nut Lock 5/16-18 UNC
178	532 19 97-82	Cargo Net Asm.	238	532 40 86-06	Trim
180	532 19 54-57	Chassis	239	532 11 04-52	Nut, Push
181	532 40 30-25	Bushing Mtg. Fender Crgo	287	817 60 04-06	Screw 1/4-20 x 3/8
182	532 40 68-59	Dash Lower			
183	874 78 05-20	Bolt Fin Hex 5/16-18 unc x 1-1/4			
189	817 00 05-12	Screw 5/16-18 x 3/4			
194	873 90 05-00	Nut Lock Hex Flange 5/16-18			
195	532 40 41-37	Plug Hole Dash Lower			

NOTE: All component dimensions given in U.S. inches
1 inch = 25.4 mm

TRACTOR - - MODEL NUMBER YTH20K46 (96045000407), PRODUCT NO. 960 45 00-04 DRIVE

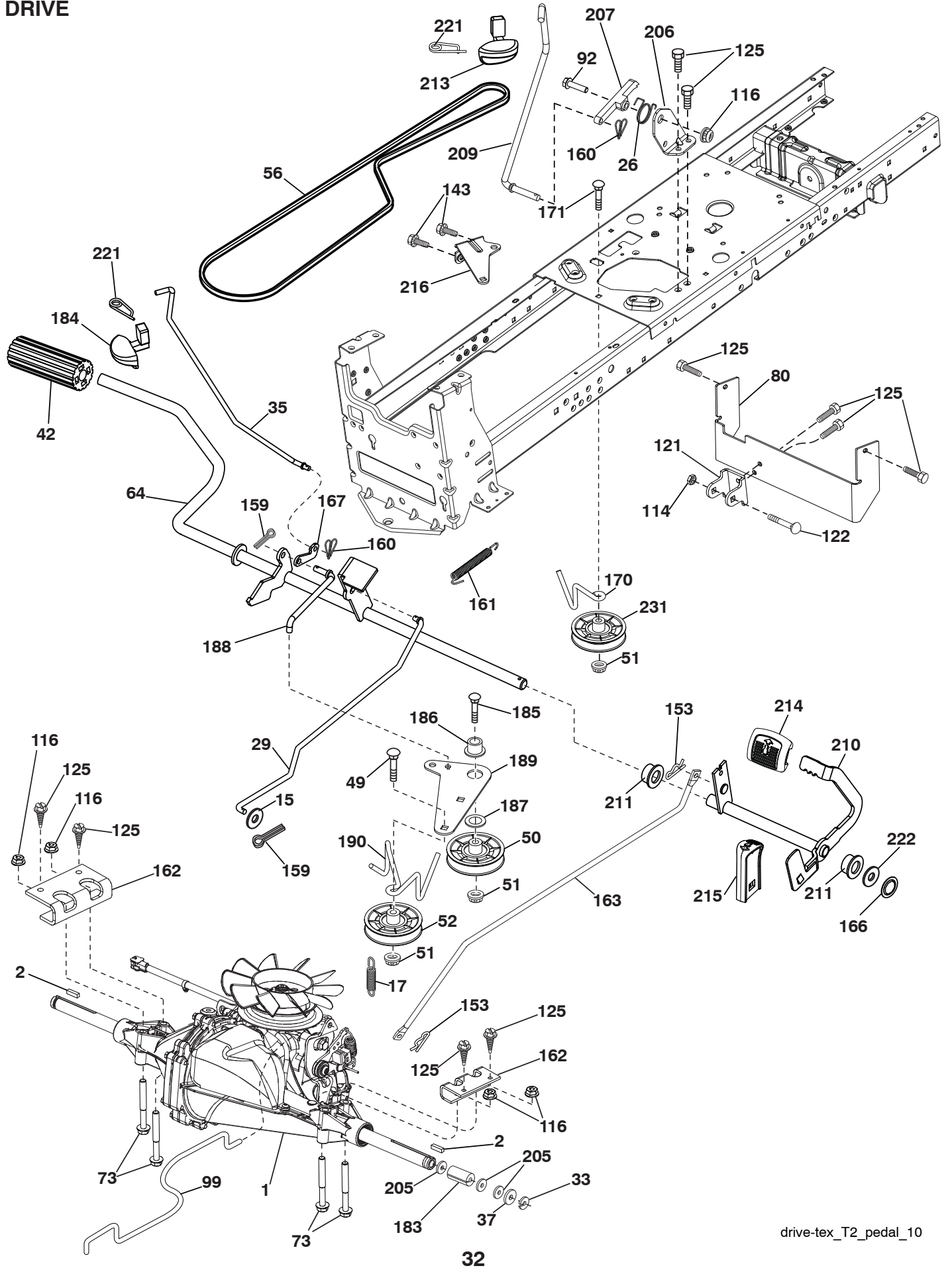

**TRACTOR - - MODEL NUMBER YTH20K46 (96045000407), PRODUCT NO. 960 45 00-04
DRIVE**

KEY NO.	PART NO.	DESCRIPTION	KEY NO.	PART NO.	DESCRIPTION
1		Transaxle, Hydro Gear T2	163	532 41 33-22	Rod Control
2	532 12 35-83	Key Square	166	532 19 72-90	Nut Push
15	819 13 13-16	Washer 13/32 x 13/16 x 16 Ga.	167	532 40 52-57	Latch Brake Parking
17	532 19 72-96	Spring, Brake	170	532 41 34-30	Keeper V-Idler
26	532 19 96-79	Spring Return Cruise	171	872 11 06-22	Bolt
29	532 40 83-91	Rod, Brake	183	532 15 69-72	Spacer Axle
33	812 00 00-01	Ring E	184	532 40 31-18	Handle Parking Brake
35	532 19 95-91	Rod, Brake, Park	185	872 11 06-20	Bolt
37	532 12 17-49	Washer 25/32 x 1-1/4 x 16 Ga.	186	532 19 43-21	Spacer Retainer
42	532 12 48-72	Cover, Foot Pedal	187	819 13 32-10	Washer
49	872 11 06-14	Bolt	188	532 19 43-23	Link Clutch Ground Drive
50	532 19 43-27	Pulley Idler Flat	189	532 19 43-17	Bellcrank Ground Drive
51	873 90 06-00	Lock Nut 3/8-16	190	532 19 43-18	Keeper Bellcrank Ground Drive
52	532 19 43-26	Idler V-Groove 910" Offset	205	532 12 17-48	Washer 25/32 x 1-5/8 x 16 Ga.
56	532 12 59-07	V-Belt, Drive	206	532 19 78-67	Bracket Mount Latch Cruise
64	532 19 78-65	Shaft Asm. Pedal Brake Control	207	532 19 78-68	Latch Control Cruise
73	874 49 05-44	Bolt Hex 5/16-18 Gr. 5	208	532 19 78-69	Gear Sector Control Cruise
80	532 40 83-93	Strap Torque	209	532 19 95-92	Rod Control Cruise
92	874 76 05-20	Bolt Fin Hex 5/16-18 unc x 1.25	210	532 40 09-80	Rocker Asm. Pedal Control
99	532 40 84-18	Rod Spring Bypass	211	532 12 01-83	Bearing Nylon
114	873 80 05-00	Nut Lock HX W/Ins 5/16-18	213	532 40 31-19	Knob Control Cruise
116	873 90 05-00	Nut Lock Hex Flange 5/16-18	214	532 40 17-22	Pedal Forward
121	532 17 56-11	Bracket Strap Torque	215	532 40 17-23	Pedal Reverse
122	872 01 05-20	Bolt 5/16-18 x 2.50	216	532 19 61-31	Bracket Pulley Idler
125	817 00 05-12	Screw 5/16-18 x 3/4	221	532 40 31-87	Retainer Spring Clip Handle
143	817 49 05-08	Screw 5/16-18 x 1/2	222	879 21 20-10	Washer 21/32 x 1-1/4 10 Ga.
153	532 12 47-88	Retainer Spring 1"	231	532 40 72-87	Idler V-Groove 1.688" Offset
159	876 02 04-12	Pin Cotter 1/8 x 3/4			
160	532 16 94-84	Retainer Clip			
161	532 10 57-09	Spring, Return, Clutch			
162	532 40 87-84	Adapter Transaxle			

NOTE: All component dimensions given in U.S. inches
1 inch = 25.4 mm

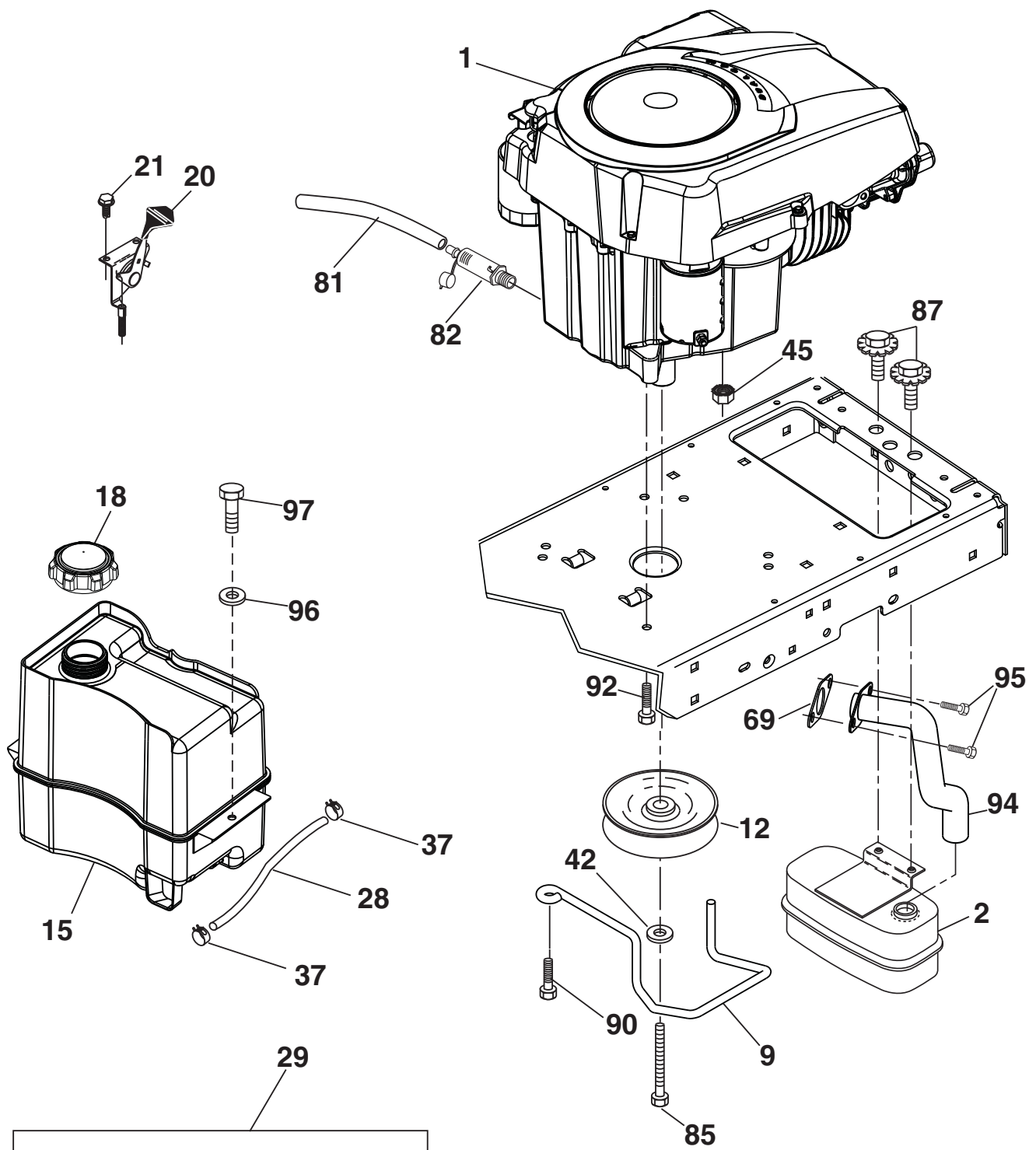

SPARK ARRESTER KIT

engine-tex_Kohl_7

**TRACTOR - - MODEL NUMBER YTH20K46 (96045000407), PRODUCT NO. 960 45 00-04
ENGINE**

KEY NO.	PART NO.	DESCRIPTION
1	-----	Engine Kohler Model No. SV620
2	532 18 86-55	Muffler
9	532 19 43-19	Keeper Belt Engine
12	532 40 51-40	Pulley Engine
15	532 40 74-89	Tank Fuel
18	532 19 77-25	Cap Asm
20	532 40 15-08	Control Throttle
21	532 41 63-58	Screw # 10 x 0.750
28	532 40 11-37	Fuel Line
29	532 13 71-80	Spark Arrester Kit
37	532 12 34-87	Clamp Hose
42	810 04 07-00	Washer Lock 7/16
45	873 51 04-00	Nut Keps Hex 1/4-20 unc
69	532 18 59-09	Gasket
81	532 14 84-56	Tube Drain Oil Easy
82	532 18 16-54	Plug Drain Oil
85	532 17 39-37	Bolt Hex 7/16-20 x 4 x Gr. 5-1.5 Thr
87	537 17 18-77	Bolt 5/16-18 UNC x 3/4 w/Sems
90	817 00 06-16	Screw 3/8-16 x 1
92	817 12 06-16	Screw 3/8-16 x 1
94	532 18 86-54	Tube Exhaust
95	532 19 23-34	Screw Socket Hd. 5/16-18 x .75
96	819 09 14-16	Washer 9/32 x 7/8 x 16 Ga.
97	817 67 04-12	Screw 1/4-20 x 3/4

NOTE: All component dimensions given in U.S. inches
1 inch = 25.4 mm

**TRACTOR - - MODEL NUMBER YTH20K46 (96045000407), PRODUCT NO. 960 45 00-04
STEERING ASSEMBLY**

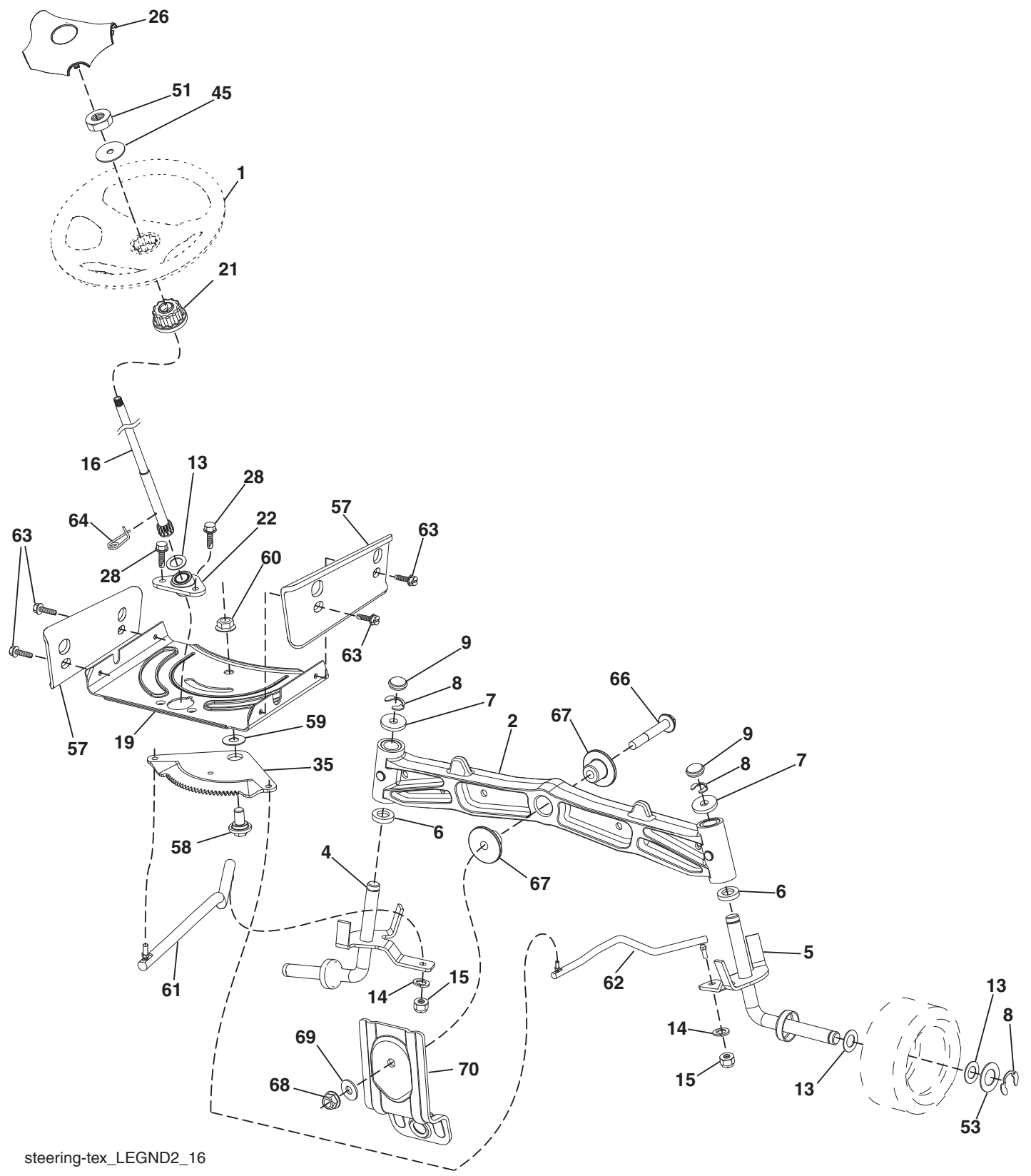

steering-tex_LEGND2_16

**TRACTOR - - MODEL NUMBER YTH20K46 (96045000407), PRODUCT NO. 960 45 00-04
STEERING ASSEMBLY**

KEY NO.	PART NO.	DESCRIPTION
1	532 19 39-43	Wheel, Steering
2	532 19 59-68	Axle Cast Iron
4	532 40 30-87	Spindle Asm., LH
5	532 40 30-88	Spindle Asm., RH
6	532 12 49-31	Bearing, Race Thrust Harden
7	532 12 17-48	Washer 25/32 x 1-5/8 x 16 Ga.
8	812 00 00-29	Ring, Klip #T5304-75
9	532 12 12-32	Cap, Spindle
13	532 12 17-49	Washer 25/32 x 1-1/4 x 16 Ga.
14	810 04 06-00	Washer, Lock Hvy Hlcl Spr 3/8
15	873 54 06-00	Nut, Crown Lock 3/8-24 unf
16	532 40 82-19	Shaft Steering
19	532 19 47-29	Plate Steering
21	532 18 67-37	Adapter, Wheel Steering
22	532 19 48-45	Bushing, Strg. Blk
26	532 19 36-52	Insert, Wheel Steering
28	817 00 06-12	Screw 3/8-16 x 3/4
35	532 19 47-32	Gear, Sector Plate
45	819 18 38-12	Washer 9/16 ID x 2-3/8 OD 12 Ga.
51	873 94 08-00	Nut Hex Jam Toplock 1/2-20 unf
53	532 18 89-67	Washer Hardened .793x1.637x.060
57	532 40 74-65	Bracket Upstop
58	532 19 47-47	Bolt Shoulder Sector Pivot CFM
59	532 19 47-48	Washer Thrust Sector Steering
60	873 97 10-00	Nut Flange Lock 5/8-11
61	532 19 47-40	Draglink LH
62	532 19 47-41	Draglink, RH
63	817 00 05-12	Screw 5/16-18 x 3/4
64	532 19 98-49	Retainer Clip Spring Steering
66	871 02 07-48	Bolt Hex Fghd 7/16-14 x 3 Serr
67	532 19 47-37	Bushing PM Front Axle
68	873 90 07-00	Nut Lock Flange 7/16-14 Gr. 5
69	532 19 91-62	Washer 1.5 x .505 x .118
70	532 19 61-97	Bracket Deck Susp. Front

NOTE: All component dimensions given in U.S. inches
1 inch = 25.4 mm

**TRACTOR - - MODEL NUMBER YTH20K46 (96045000407), PRODUCT NO. 960 45 00-04
DECALS**

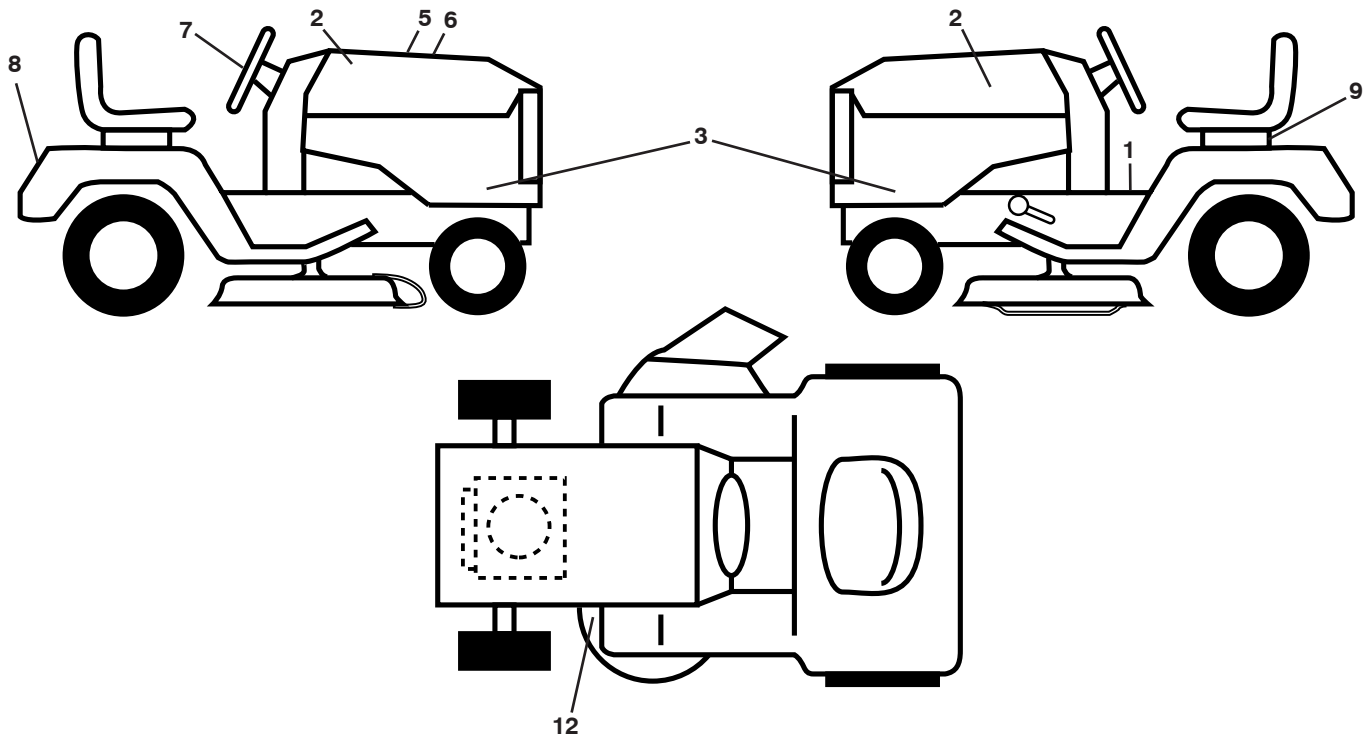

KEY NO.	PART NO.	DESCRIPTION
1	532 41 91-38	Decal, Fender Warning
2	532 41 68-38	Decal, Hood
3	532 41 01-08	Decal, Hood Panel SD
5	532 18 09-41	Decal, Customer Respons.
6	532 41 54-99	Decal, Replacement
7	532 40 44-84	Decal, Steering Wheel
8	532 19 15-54	Decal, Fender

KEY NO.	PART NO.	DESCRIPTION
9	532 14 50-05	Decal, Battery Dnge/Poi
12	532 16 03-96	Decal, Mower V-Belt Schematic
--	532 16 69-60	Decal, Bypass
--	532 41 08-05	Pad, Footrest, LH
--	532 41 08-06	Pad, Footrest, RH

WHEELS AND TIRES

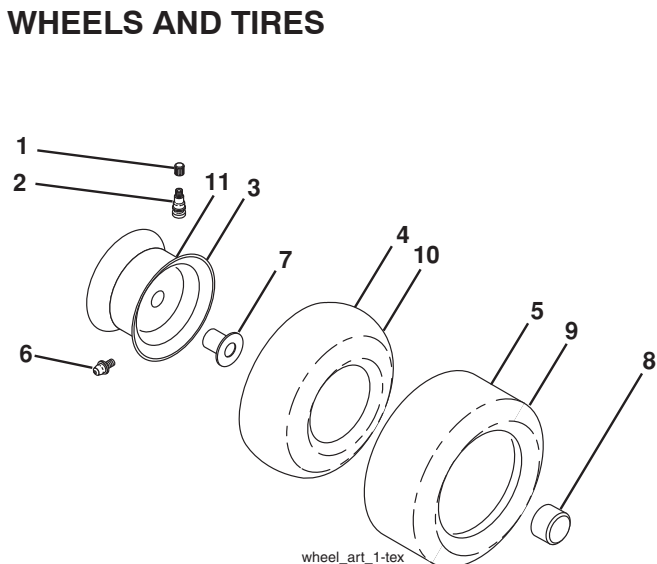

KEY NO.	PART NO.	DESCRIPTION
1	532 05 91-92	Cap Valve Tire
2	532 06 51-39	Stem Valve
3	532 13 83-36	Rim Front
4	532 05 99-04	Tube Front (Service Item Only)
5	532 10 62-22	Tire Front 15 x 6.0-6
6	532 12 49-57	Fitting Grease (Front Wheel Only)
7	532 12 49-59	Bearing Flange (Front Wheel Only)
8	532 17 50-39	Cap Axle Blk 1 50 x 1 00
9	532 10 62-68	Tire R 18 x 9.5-8 Turf Saver
10	532 12 49-26	Tube Rear (Service Item Only)
11	532 13 83-37	Rim Asm 8" rear
--	532 42 05-31	Tire R 18 x 9.5-8 Turf Saver LT
--	532 14 43-34	Sealant, Tire (10 oz. Tube)

NOTE: All component dimensions given in U.S. inches
1 inch = 25.4 mm

**TRACTOR - - MODEL NUMBER YTH20K46 (96045000407), PRODUCT NO. 960 45 00-04
SEAT ASSEMBLY**

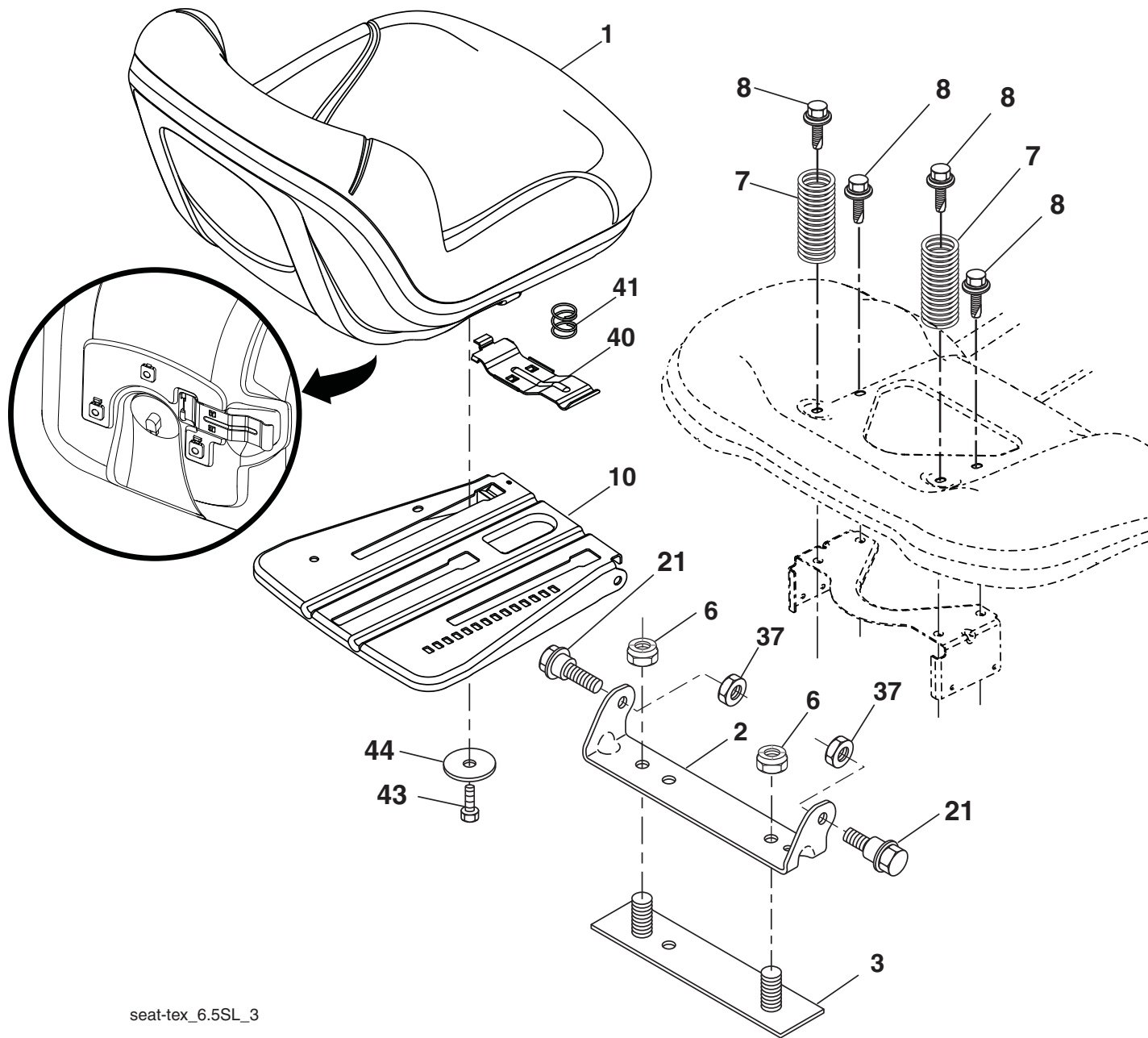

seat-tex_6.5SL_3

KEY NO.	PART NO.	DESCRIPTION
1	532 40 66-21	Seat
2	532 18 01-66	Bracket Pivot Fender
3	532 14 06-75	Strap, Asm Fender
6	873 80 06-00	Nut, Lock W/Ins. 3/8-16 unc
7	532 12 41-81	Spring, Seat Cprsn
8	532 17 18-77	Bolt 5/16-18 uncx 3/4 w/Sems
10	532 19 69-77	Pan, Seat
21	532 17 18-52	Bolt, Shoulder 5/16-18

KEY NO.	PART NO.	DESCRIPTION
37	873 80 05-00	Nut, Lock 5/16-18 unc
40	532 19 76-61	Handle Slide Seat
41	532 19 82-00	Spring Latch Seat
43	874 76 06-12	Bolt Fin Hex 3/8-16 unc x 3/4
44	819 13 38-12	Washer 13/32 x 2-3/8 x 12 Ga.

NOTE: All component dimensions given in U.S. inches
1 inch = 25.4 mm

TRACTOR - - MODEL NUMBER YTH20K46 (96045000407), PRODUCT NO. 960 45 00-04
MOWER DECK

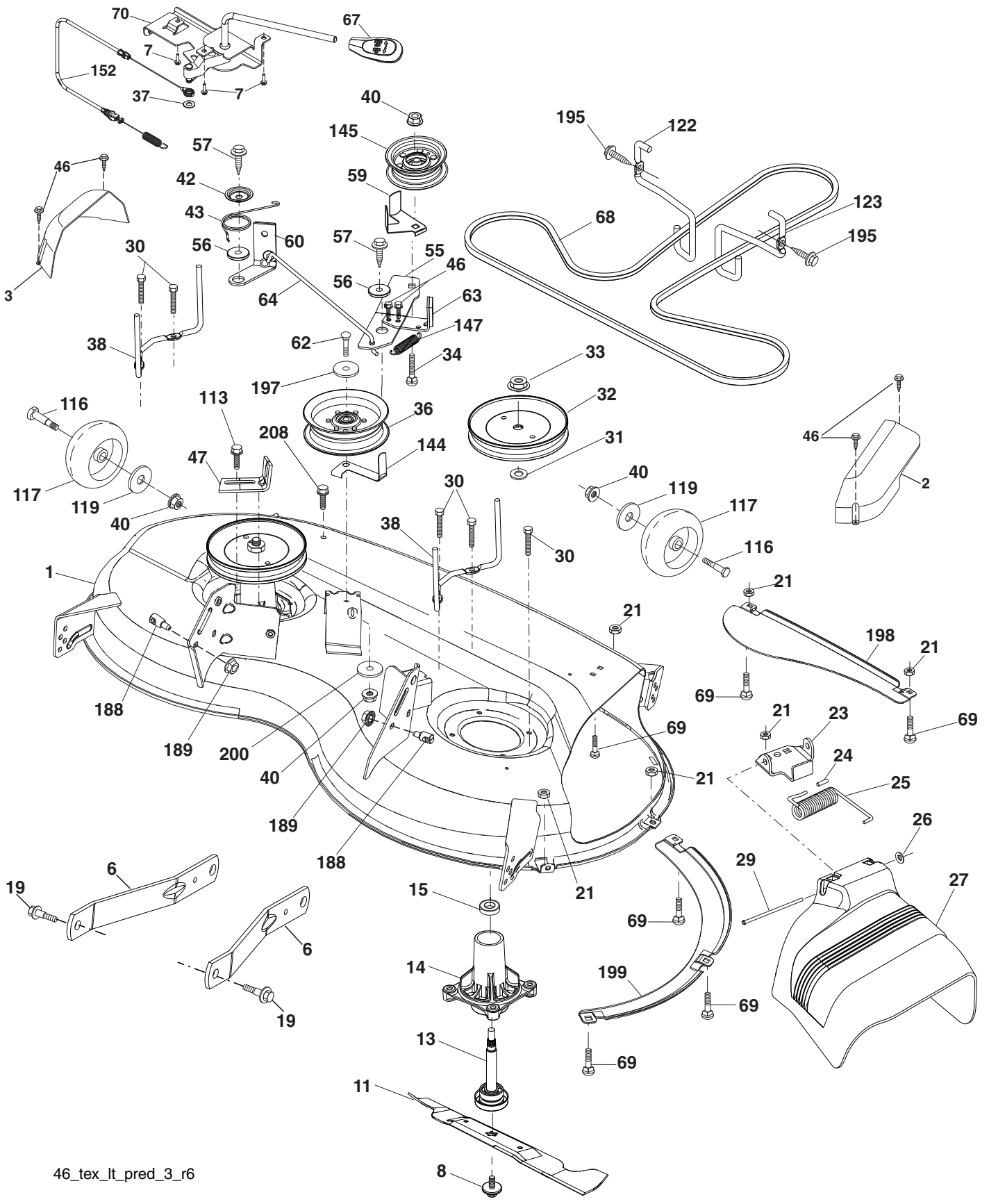

46_text_lt_pred_3_r6

**TRACTOR - - MODEL NUMBER YTH20K46 (96045000407), PRODUCT NO. 960 45 00-04
MOWER DECK**

KEY PART NO. NO.	DESCRIPTION	KEY PART NO. NO.	DESCRIPTION		
1	532 41 08-63	Mower Housing	62	874 52 06-36	Bolt 3/8-16 UNC x 2-1/4 Gr. 5
2	532 40 55-06	Cover Mandrel RH	63	532 19 94-77	Arm Brake Mower
3	532 40 55-07	Cover Mandrel LH	64	532 40 51-38	Linkage Brake
6	532 19 51-86	Arm Suspension	67	532 40 30-12	Handle, Clutch Cable
7	532 41 63-58	Screw # 10 x 0.750	68	532 40 51-43	V-Belt
8	532 19 30-03	Bolt/Washer asm 7/16-20 unf	69	872 14 05-05	Bolt
11	532 40 53-80	Blade Mower Hi Lift	70	532 40 65-63	Clutch Asm. Cable
13	532 19 28-72	Shaft Assembly, Mandrel	113	817 00 05-10	Screw 5/16-18
14	532 18 72-81	Housing, Mandrel	116	532 19 34-06	Bolt, Shoulder
15	532 11 04-85	Bearing, Ball, Mandrel	117	532 17 48-73	Wheel, Gauge
19	532 19 65-39	Bolt, Shoulder	119	819 13 20-12	Washer 13/32 x 1-1/4 x 12 Ga.
21	873 68 05-00	Nut	122	532 19 72-58	Keeper Belt Eng. LH
23	532 19 25-57	Bracket, Deflector	123	532 19 72-59	Keeper Belt Eng. RH
24	532 10 53-04	Cap, Sleeve	144	532 19 92-04	Keeper Belt
25	532 19 70-26	Spring, Torsion, Deflector	145	532 19 31-97	Pulley Idler
26	532 11 04-52	Nut, Push	147	532 40 18-72	Spring Return
27	532 40 53-57	Shield, Deflector	152	532 40 83-19	Cable Clutch Manual w/Spr.
29	532 13 14-91	Rod, Hinge	188	532 19 51-61	Stud Fastener
30	532 17 39-84	Screw Thdrol Rolling Wsh Hd	189	873 90 05-00	Nut Lock Hex Flange
31	532 18 76-90	Washer, Spacer	195	817 00 06-12	Screw 3/8-16 x 3/4
32	532 19 74-73	Pulley, Mandrel	197	819 13 13-12	Washer 13/32 x 13/16 x 12 Ga.
33	532 40 02-34	Nut, Toplock, Flanged	198	532 40 31-49	Baffle Center Front
34	872 11 06-12	Bolt Carr Sh. 3/8-16 x 1-1/2 Gr. 5	199	532 40 31-50	Baffle Front RH
36	532 19 73-79	Pulley, Idler, Flat	200	532 41 35-24	Washer 13/32 x 1 x 1/2 11 Ga.
37	819 13 13-16	Washer 13/32 x 13/16 x 16 Ga.	208	817 67 06-08	Screw 3/8-16 x 1/2
38	532 19 91-89	Keeper Belt LH Mandrel	--	532 19 28-70	Mandrel Assembly (Includes hous- ing, shaft assembly, and bearing only - pulley/nut/washer and blade bolt/washers not included)
40	873 90 06-00	Nut, Lock Flg. 3/8-16 unc	--	532 40 84-78	Replacement Mower, Complete
42	532 19 84-10	Spring Torsion Brake			
43	532 19 72-56	Spring Torsion Retainer			
46	532 13 77-29	Screw			
47	532 19 72-50	Bracket Clutch Cable			
55	532 19 72-49	Arm, Idler			
56	532 19 90-92	Spacer, Retainer			
57	817 00 06-16	Screw Hexwsh Thd 3/8-16 x 1			
59	532 14 10-43	Guard, Tuv Idler (94)			
60	532 19 94-71	Arm Brake Mower LH			

NOTE: All component dimensions given in U.S. inches
1 inch = 25.4 mm

**TRACTOR - - MODEL NUMBER YTH20K46 (96045000407), PRODUCT NO. 960 45 00-04
MOWER LIFT**

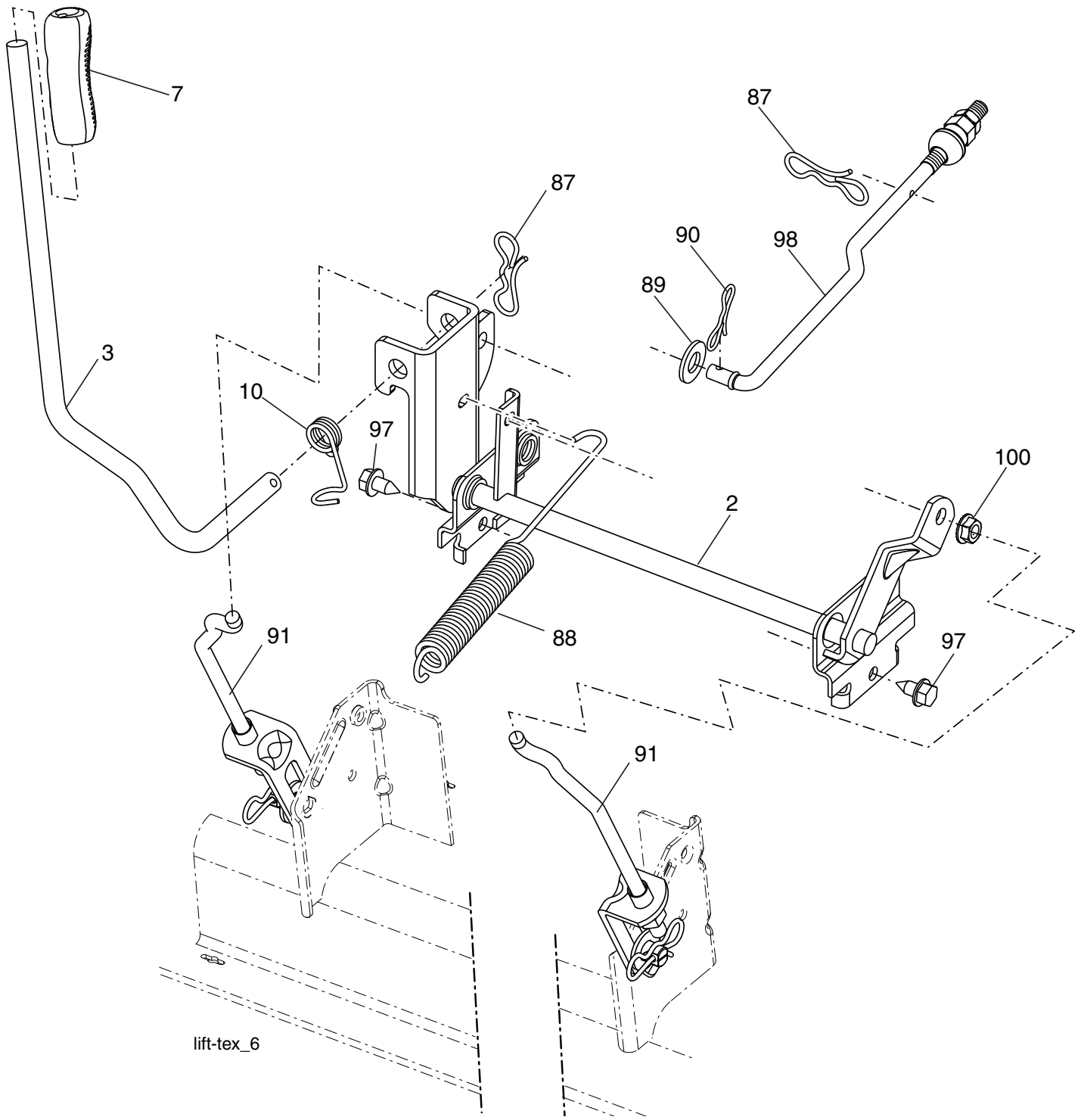

KEY NO.	PART NO.	DESCRIPTION
2	532 19 52-23	Shaft Asm., Lift
3	532 19 52-31	Lever Asm., Lift RH
7	532 41 15-55	Grip, Lever
10	532 19 63-14	Spring Torsion
87	532 19 42-09	Pin Cotter 7/16 Bow Tie Lock
88	532 41 07-10	Spring Lift Assist
89	819 19 19-12	Washer Clear Zinc
90	532 19 42-08	Pin Cotter 5/16 Bow Tie Lock

KEY NO.	PART NO.	DESCRIPTION
91	532 19 51-81	Link Lift Susp Mower Rear
97	817 00 06-12	Screw 3/8-16 x .75 Smgml Tap/R.Z
98	532 19 52-70	Link Lift Susp. Front Mower
100	873 93 06-00	Nut Center Lock 3/8-16 UNC

NOTE: All component dimensions given in U.S. inches
1 inch = 25.4 mm

