

Parts Manual

WH3615/966947001

WH4817/966947002

WH5217/966947003

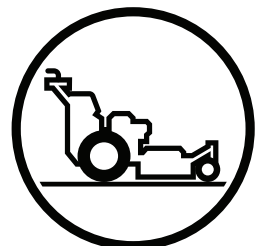

Please read the operator's manual carefully and make sure you understand the instructions before using the machine.

English

CONTENTS

FRAME.....	4	48" MOWER DECK	
ENGINE.....	6	Upper Deck.....	20
HANDLE AND CONTROLS.....	8	Lower Deck.....	22
PARKING BRAKE.....	10	52" MOWER DECK	
HYDRO PUMP-MOTOR.....	12	Upper Deck.....	24
WHEELS AND TIRES.....	14	Lower Deck.....	26
36" MOWER DECK		DECALS.....	28
Upper Deck.....	16		
Lower Deck.....	18		

NOTE: ALL FASTENERS ARE GRADE 5 UNLESS OTHERWISE SPECIFIED.

FRAME

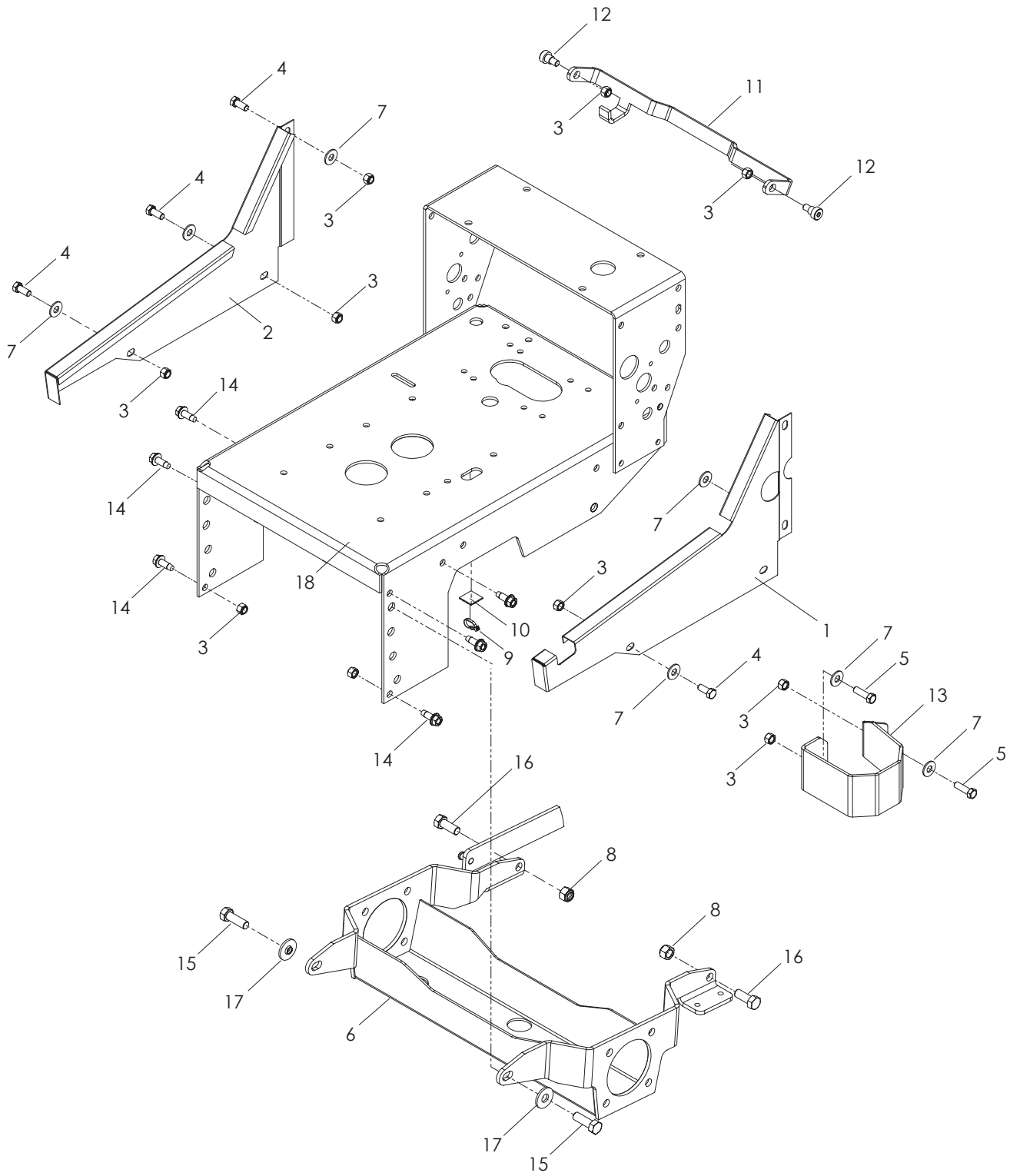

FRAME

ITEM	PART NO.	QTY.	DESCRIPTION	ITEM	PART NO.	QTY.	DESCRIPTION
1..	539 132558....	1....	PANEL, SIDE, RH	12..	539 113621	2....	SB $\frac{3}{8}$ -16 x $\frac{3}{8}$ SKT HD
2..	539 132560....	1....	PANEL, SIDE, LH	13..	505 189002....	1....	GUARD, FILTER
3..	539 976979..	14....	NUT $\frac{3}{8}$ -16 HEX NYLOC	14..	539 107476....	6....	BOLT $\frac{3}{8}$ -16 x 1 THD FRM
4..	539 108507...11....	HCS $\frac{3}{8}$ -16 x $\frac{7}{8}$		15..	539 108374....	2....	HCS $\frac{1}{2}$ -13 x $1\frac{1}{2}$
5..	539 976941....	4....	HCS $\frac{3}{8}$ -16 x $1\frac{1}{4}$	16..	539 108369....	2....	HCS $\frac{1}{2}$ -13 x $1\frac{1}{4}$
6..	539 132509....	1....	AXLE, HYDRO	17..	539 109554....	2....	WASHER $\frac{1}{2}$ FLAT
7..	539 990517....	8....	WASHER $\frac{3}{8}$ FLAT	18..	522 478001....	1....	ENGINE DECK W/DECAL
8..	539 101331....	2....	NUT $\frac{1}{2}$ HEX NYLOC		NOT SHOWN		
9..	539 976856....	2....	WIRE TIE		539 109104	1	HARNES, LOWER
10..	539 110863....	1....	MOUNTING BLOCK		532 198316	1	ADAPTER, HARNES
11..	539 132556....	1....	BAR, THROW OUT				

ENGINE

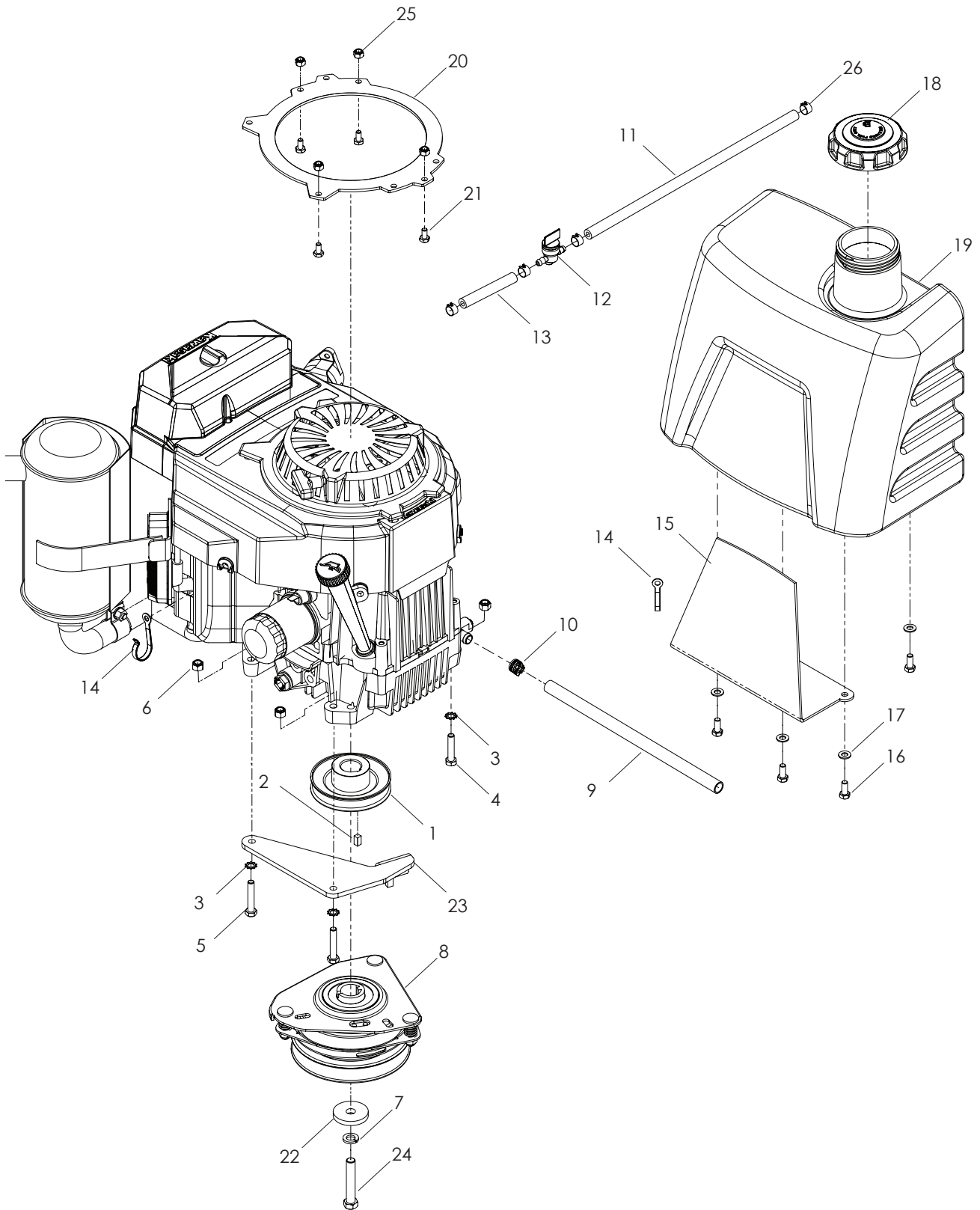

ENGINE

ITEM	PART NO.	QTY.	DESCRIPTION	ITEM	PART NO.	QTY.	DESCRIPTION
1..	539 132525....	1....	PULLEY	14..	539 107098....	2....	CLAMP
2..	539 105718....	1....	KEY ¼" SQ x ½"	15..	539 132633....	1....	PLATE
3..	539 109556....	4....	LOCK WASHER 5/16 STAR	16..	539 976934....	4....	HCS 5/16-18 x ¾
4..	539 976935....	2....	HCS 5/16-18 x 1½	17..	539 990188....	4....	WASHER 5/16 SAE FLAT
5..	539 990669....	2....	HCS 5/16-18 x 1¾	18..	539 106188....	1....	CAP, FUEL TANK
6..	539 990717....	4....	NUT 5/16-18 HEX NYLOC	19..	539 132549....	1....	TANK, FUEL
7..	539 990247....	1....	LOCKWASHER 7/16 SLOT	20..	539 132548....	1....	ADAPTER, RECOIL
8..	532 400008....	1....	CLUTCH 90 FT/LB	21..	539 990071....	4....	HCS ¼-20 x ½
9..	539 107937....	1....	HOSE, OIL DRAIN	22..	539 106504....	1....	WASHER, HEAVY
10..	539 976966....	4....	CLAMP, HOSE	23..	539 132527....	1....	CLUTCH STOP
11..	539 108212....	1....	FUEL LINE, 12"	24..	539 991120....	1....	HCS 7/16-20 x 2½
12..	539 916325....	1....	FUEL VALVE	25..	539 976978....	4....	NUT ¼-20 HEX NYLOC
13..	505 215101....	1....	FUEL LINE, 2½"	26..	539 912222....	3....	CLAMP

HANDLE AND CONTROLS

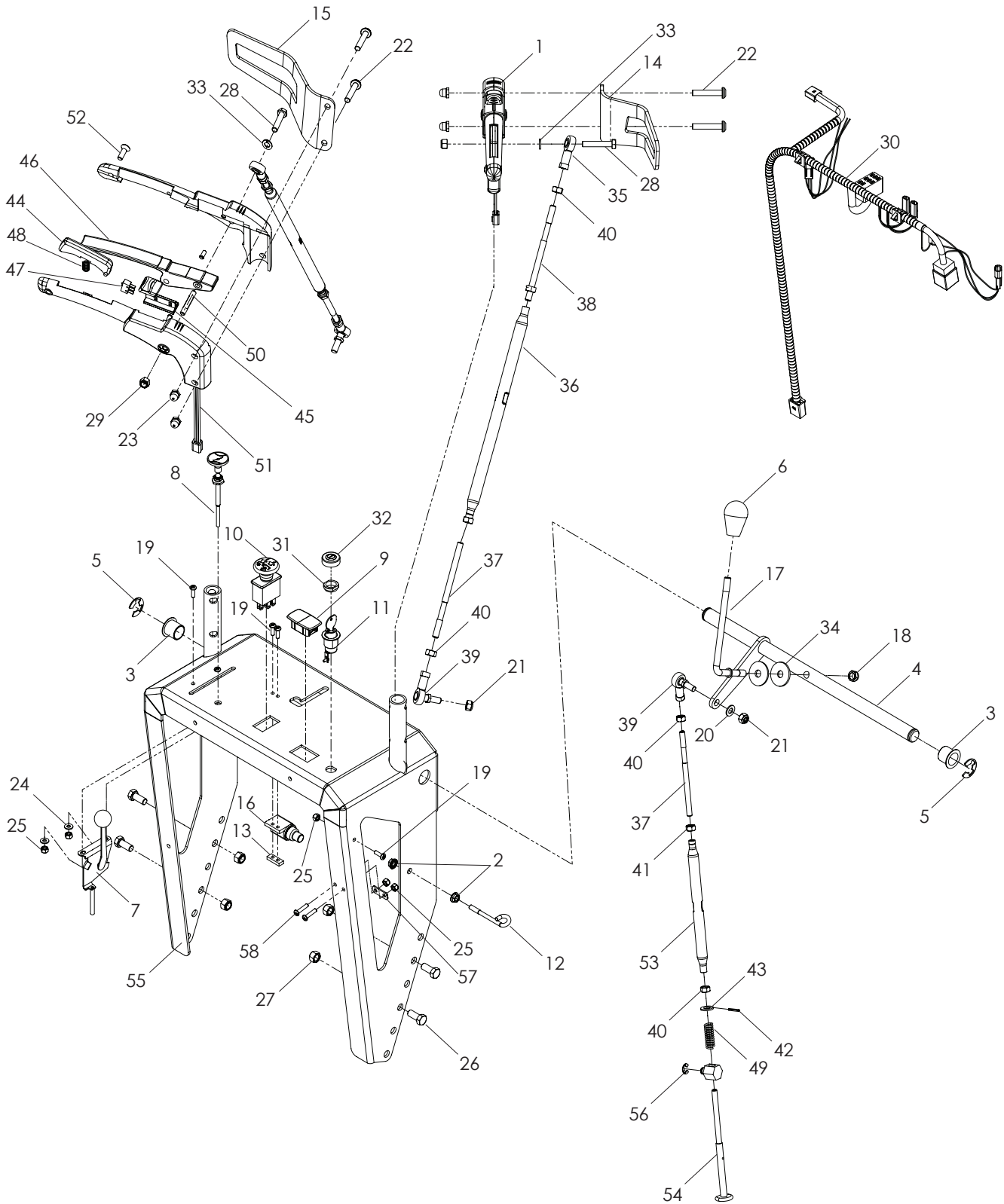

HANDLE AND CONTROLS

ITEM	PART NO.	QTY.	DESCRIPTION	ITEM	PART NO.	QTY.	DESCRIPTION
1..	539 132623....	2....	GRIP ASSEM	32..	539 103178....	1....	CAP, IGNITION SWITCH NUT
2..	539 990585....	2....	NUT ⁵ / ₁₆ -18 HEX WHIZLK	33..	539 990187....	2....	WASHER ⁵ / ₁₆ SLW
3..	539 132520....	2....	BEARING, FLANGE	34..	539 912063....	2....	WASHER, CONE
4..	539 132628....	1....	SPEED CONTROL	35..	539 132602....	1....	ROD END 8 MM, RH
5..	539 132629....	2....	E RING, 20MM	36..	539 132601....	1....	TUBE, ADJUSTING
6..	539 132624....	1....	KNOB, SHIFT	37..	539 132605....	1....	STUD, LH
7..	539 132688....	1....	THROTTLE CONTROL	38..	539 132604....	1....	STUD, RH
8..	539 130208....	1....	CONTROL, CHOKE	39..	539 132603....	1....	ROD END 8 MM, W/STUD
9..	532 404951....	1....	PLUG, DASH, SVC MINDER	40..	539 132607....	3....	NUT .8MM x 1.25 HEX
10..	539 101768....	1....	CLUTCH SWITCH	41..	510 098701....	1....	NUT .8MM x 1.25 LH
11..	539 911853....	1....	SWITCH, IGNITION	42..	539 132614....	1....	ROLL PIN 3 MM
12..	539 132676....	1....	GUIDE, ROPE	43..	510 098601....	1....	WASHER, 10 MM
13..	539 102678....	1....	PLATE, NUT	44..	539 132674....	2....	ACTUATOR, OPC
14..	522 421802....	1....	GUARD, HAND RH	45..	539 132617....	2....	LOCK, NEUTRAL
15..	522 421702....	1....	GUARD, HAND LH	46..	539 132618....	2....	LEVER
16..	539 020017....	1....	SWITCH, NC	47..	539 132620....	2....	SWITCH
17..	539 132626....	1....	ROD, SHIFT	48..	539 132599....	2....	SPRING
18..	539 200282....	1....	NUT ³ / ₈ -16 HEX JAM NYLOC	49..	539 101224....	1....	SPRING
19..	539 990411....	5....	SCREW #10-24 x 1/2 HEX	50..	539 132635....	2....	PIN, GROOVE 1/4 x 1/2
20..	539 990188....	1....	WASHER ⁵ / ₁₆ SAE FLAT	51..	539 132675....	2....	HARNESS, SWITCH
21..	539 103153....	3....	NUT M8 x 1.25 NYLOC	52..	539 132677....	2....	SCREW, OVAL HEAD 6MM
22..	505 203301....	4....	SCREW, PAN HD ⁵ / ₁₆ -18 x 1 1/4	53..	539 132609....	1....	TUBE, ADJUSTING
23..	505 203401....	4....	NUT, ACORN ⁵ / ₁₆ -18	54..	539 132608....	1....	ROD, HEADED
24..	539 105408....	2....	WASHER #10 FLAT	55..	522 478101....	1....	UPPER HANDLE W/DECAL
25..	539 976977....	5....	NUT #10-24 HEX NYLOC	56..	539 132613....	1....	E-RING, 10MM
26..	539 108507....	4....	HCS ³ / ₈ -16 x 7/8	57..	510 417602....	1....	PLATE, RESISTOR
27..	539 976979....	4....	NUT ³ / ₈ -16 HEX NYLOC	58..	539 102617....	2....	SCREW #10-24 x 7/8 RD HD
28..	539 990669....	2....	HCS ⁵ / ₁₆ -18 x 1 3/4	NOT SHOWN			
29..	539 990717....	2....	NUT ⁵ / ₁₆ -18 HEX NYLOC	539 110802....	1....	SERVICE METER (OPTIONAL)	
30..	510 366901....	1....	HARNESS, UPPER HANDLE				
31..	539 103177....	1....	NUT, IGNITION SWITCH				

PARKING BRAKE

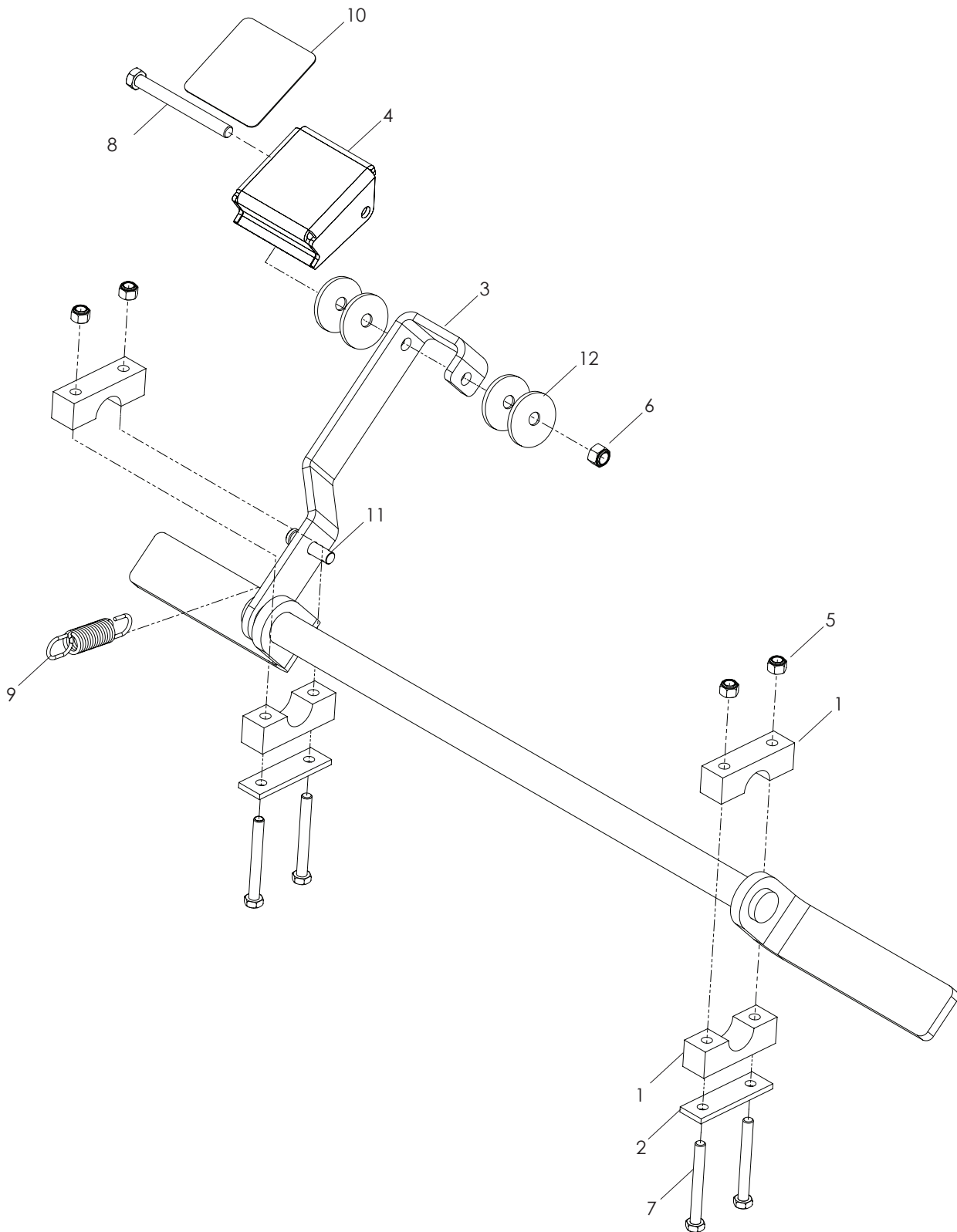

PARKING BRAKE

ITEM	PART NO.	QTY.	DESCRIPTION
1..	539 104808....	4....	PILLOW BLOCK
2..	539 104807....	2....	REINFORCEMENT BAR
3..	539 132685....	1....	PARK BRAKE
4..	510 283402....	1....	PEDAL
5..	539 990717....	4....	NUT $5/16$ -18 HEX NYLOC
6..	539 976979....	1....	NUT $3/8$ -16 HEX NYLOC

ITEM	PART NO.	QTY.	DESCRIPTION
7..	539 101721....	4....	HCS $5/16$ -18 x $2\frac{3}{4}$
8..	539 991126....	1....	HCS $3/8$ -16 x $3\frac{3}{4}$
9..	510 136301....	1....	SPRING, EXTENSION
10..	539 105187....	1....	PAD, ANTI-SKID
11..	539 102455....	1....	PIN, CLEVIS $3/8$ x $1\frac{1}{2}$
12..	539 102998....	4....	WASHER, FRICTION

HYDRO PUMP-MOTOR

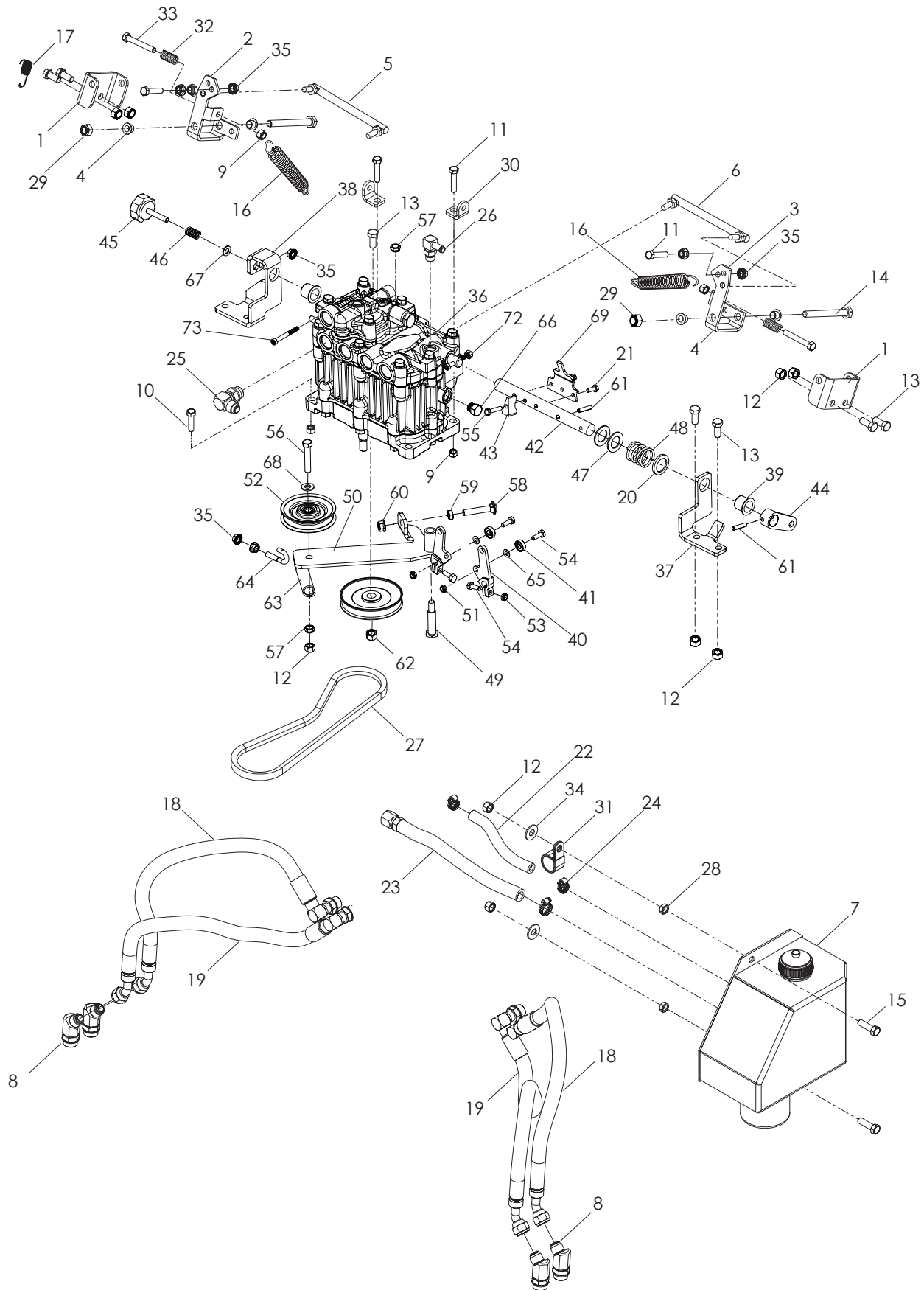

HYDRO PUMP-MOTOR

ITEM	PART NO.	QTY.	DESCRIPTION	ITEM	PART NO.	QTY.	DESCRIPTION
1..	539 132535....	2....	U BRACKET	38..	539 132513....	1....	SUPPORT, CAM RH
2..	539 132537....	1....	BELLCRANK, RH	39..	539 132520....	2....	BEARING, FLANGE
3..	539 132539....	1....	BELLCRANK, LH	40..	539 132516....	2....	ARM, HYDRO
4..	539 132533....	4....	BEARING, FLANGE	41..	539 132523....	2....	BEARING, FOLLOWER
5..	539 132550....	1....	LINK, CONTROL, RH	42..	539 132519....	1....	SHAFT, CAM
6..	539 132551....	1....	LINK, CONTROL, LH	43..	539 132518....	1....	CAM, TRACKING
7..	505 247301....	1....	RESERVOIR	44..	539 132517....	1....	ARM, SPEED CONTROL
8..	539 132561....	4....	ELBOW 45° STRAIGHT THD	45..	539 103003....	1....	KNOB, ADJUSTMENT
9..	539 990717....	6....	NUT ⁵ / ₁₆ -18 HEX NYLOC	46..	539 132687....	1....	SPRING, COMPRESSION
10..	539 990627....	2....	HCS ⁵ / ₁₆ -18 x 1¼	47..	539 132521....	2....	WASHER, 20MM
11..	539 976935....	4....	HCS ⁵ / ₁₆ -18 x 1½	48..	539 132524....	1....	SPRING, COMPRESSION
12..	539 976979....	8....	NUT ³ / ₈ -16 HEX NYLOC	49..	539 131727....	1....	PULLEY, PUMP
13..	539 108507....	7....	HCS ³ / ₈ -16 x ⁷ / ₈	50..	539 132532....	1....	IDLER ARM, BLK
14..	510 129901....	2....	HCS M10-1.58 x 100 GR 8.8	51..	539 110222....	1....	SHOULDER BOLT
15..	539 976941....	4....	HCS ³ / ₈ -16 x 1¼	52..	539 113683....	1....	V-IDLER
16..	539 916159....	2....	SPRING	53..	539 108120....	4....	NUT ¼-20 HEX THIN NYLOC
17..	510 206101....	1....	SPRING, EXTENSION	54..	539 990580....	4....	HCS ¼-20 x ³ / ₄
18..	505 203201....	2....	HOSE, 4	55..	539 106307....	1....	HCS M6-1.0 x 30MM GR 8.8
19..	505 203101....	2....	HOSE, 3	56..	539 990588....	1....	HCS ³ / ₈ -16 x 2
20..	510 362801....	1....	WASHER, FIBER	57..	539 200282....	2....	NUT ³ / ₈ -16 HEX JAM NYLOC
21..	539 107705....	2....	HCS M6-1.0 x 16MM GR 8.8	58..	539 100145....	1....	RHSNB ³ / ₈ -16 x 2
22..	505 280201....	1....	HOSE, RETURN	59..	539 109332....	1....	NUT ³ / ₈ -16 HEX JAM
23..	505 280101....	1....	HOSE, SUCTION	60..	539 990613....	1....	NUT ³ / ₈ -16 HEX WHIZLK
24..	539 976966....	3....	CLAMP, HOSE	61..	505 224001....	2....	ROLL PIN, 6 MM x 30 MM
25..	539 101242....	1....	ELBOW 90°	62..	539 131528....	1....	NUT, M10-1.5 L/H HEX
26..	505 280401....	1....	FITTING 90°	63..	539 010195....	1....	SPRING
27..	539 106725....	1....	BELT	64..	539 112896....	1....	J-BOLT
28..	539 109332....	2....	NUT ³ / ₈ -16 HEX JAM	65..	539 103547....	2....	WASHER
29..	510 130001....	2....	NUT, M10-1.5 NYLON RING	66..	539 131895....	1....	PLUG
30..	510 111002....	2....	BRACKET, SPRING	67..	539 990188....	1....	WASHER ⁵ / ₁₆ SAE FLAT
31..	539 107891....	1....	CLIP	68..	539 990122....	1....	WASHER, ³ / ₈ SAE FLT
32..	539 101224....	2....	SPRING	69..	539 132515....	1....	PLATE, NEUTRAL STOP
33..	539 976938....	2....	HCS ⁵ / ₁₆ -18 x 2¼	70..	539 103153....	4....	NUT M8 x 1.25 NYLOC
34..	539 990517....	2....	WASHER ³ / ₈ FLAT	71..	539 990187....	2....	WASHER ⁵ / ₁₆ SLW
35..	539 990585....	7....	NUT ⁵ / ₁₆ -18 HEX WHIZLK	72..	539 976977....	2....	NUT #10-24 HEX NYLOC
36..	521 976001....	1....	PUMP, DUP10S	73..	521 976101....	2....	SCREW #10-24 SCKT HD
37..	539 132511....	1....	SUPPORT, CAM LH				

WHEELS AND TIRES

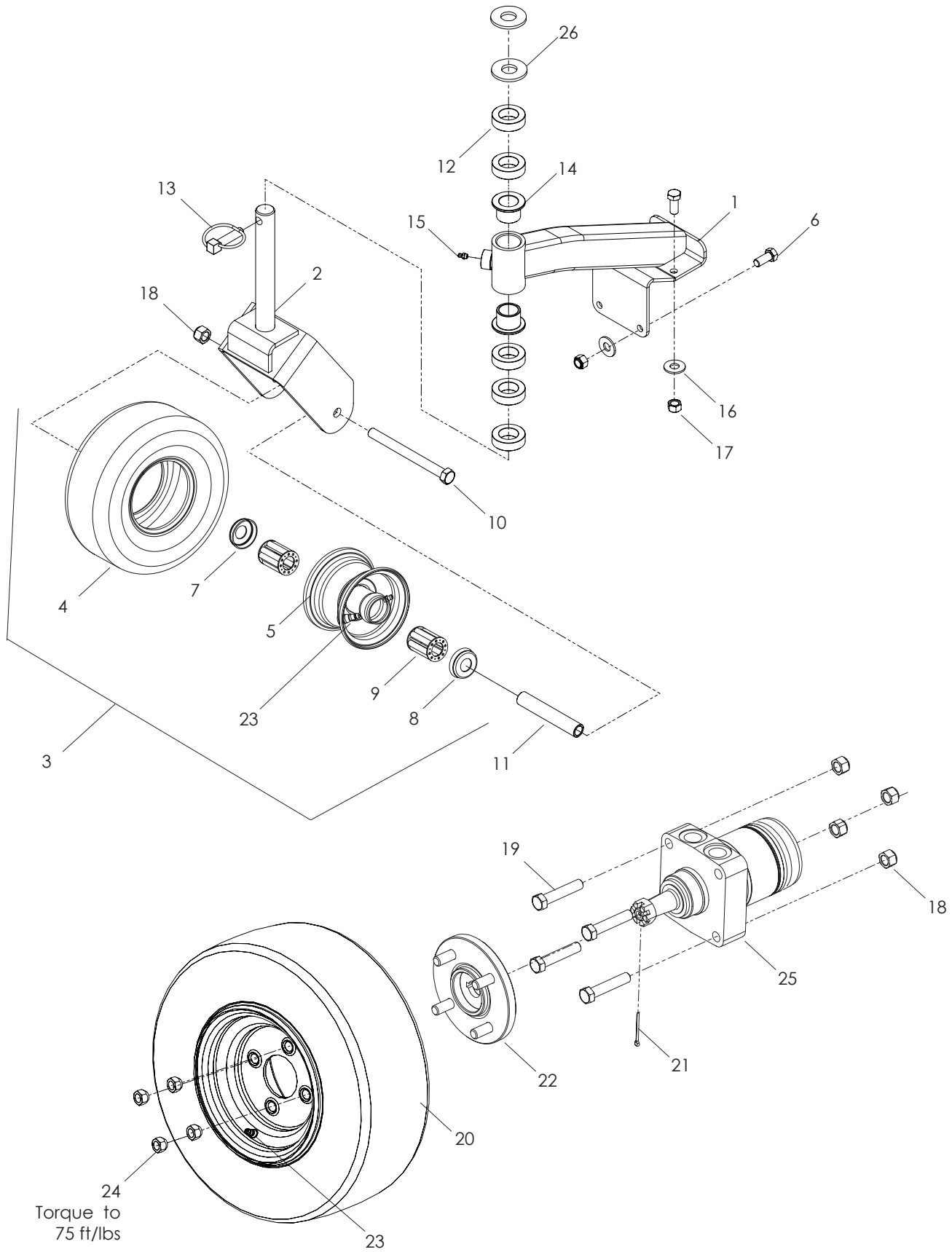

WHEELS AND TIRES

ITEM	PART NO.	QTY.	DESCRIPTION	ITEM	PART NO.	QTY.	DESCRIPTION
1..	539 132683....	1....	CASTER ARM	15..	539 976998....	1....	ZERK
2..	539 132588....	1....	CASTER FORK	16..	539 990517....	8....	WASHER $\frac{3}{8}$ FLAT
3..	539 104556....	1....	WHEEL ASSEMBLY, CASTER	17..	539 976979....	7....	NUT $\frac{3}{8}$ -16 HEX NYLOC
4..	539 101905....	1....	TIRE, CASTER	18..	539 101331..	10....	NUT $\frac{1}{2}$ HEX NYLOC
5..	539 104618....	1....	RIM	19..	539 108346....	8....	HCS $\frac{1}{2}$ -13 x $2\frac{1}{2}$
6..	539 108507....	8....	HCS $\frac{3}{8}$ -16 x $\frac{7}{8}$	20..	522 412901....	2....	WHEEL ASSM, REAR 36
7..	539 923557....	1....	ENDCAP		522 413001	2	WHEEL ASSM, REAR 48/52
8..	539 977356....	1....	NOTCHED ENDCAP	21..	539 990297....	2....	PIN $\frac{1}{8}$ x $1\frac{1}{2}$ COTTER
9..	539 977353....	2....	ROLLER BEARING	22..	539 132689....	2....	HUB, WHEEL
10..	539 101907....	1....	HCS $\frac{1}{2}$ -13 x $5\frac{1}{2}$	23..	539 912234....	4....	AIR VALVE
11..	539 101872....	1....	SPACER, CASTER	24..	539 101173....	8....	NUT, LUG $\frac{1}{2}$
12..	539 132678....	6....	SPACER, HEIGHT	25..	539 103527....	1....	MOTOR, LT
13..	539 101874....	1....	LYNCH PIN $\frac{7}{16}$		521 911601	1	MOTOR, REVERSED, RT
14..	539 106656....	2....	BUSHING	26..	521 994501....	2....	SPACER, HT ADJ $\frac{1}{4}$

36" MOWER DECK

Upper Deck

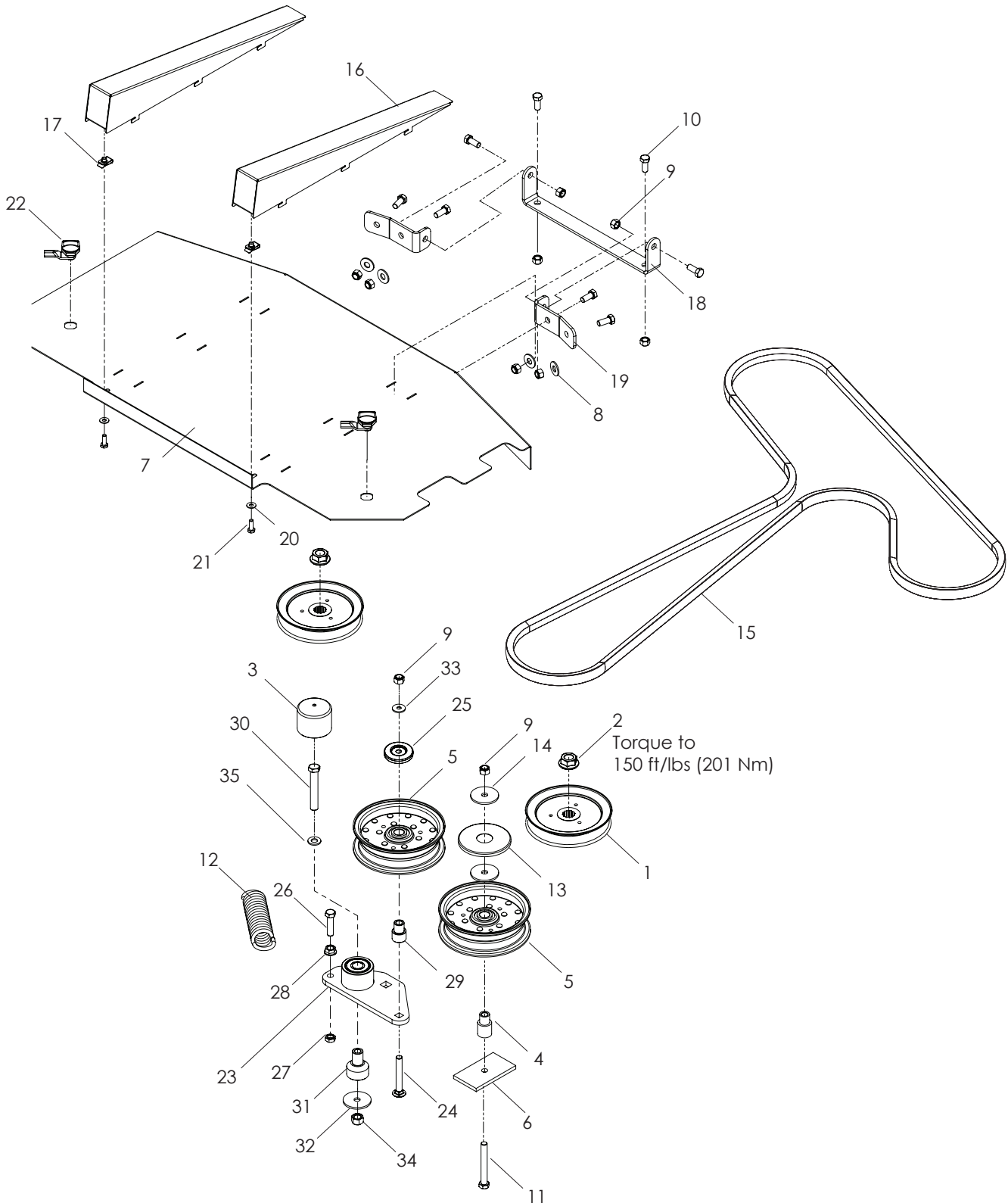

36" MOWER DECK

ITEM	PART NO.	QTY.	DESCRIPTION	ITEM	PART NO.	QTY.	DESCRIPTION
1..	522 023801....	2....	PULLEY	19..	539 132579....	1....	BASE, HINGE
2..	539 130563....	2....	NUT 3/4-16 FLANGE	20..	539 990055....	2....	WASHER, 1/4 FLAT SAE
3..	539 114823....	1....	CAP, VINYL	21..	539 990580....	2....	HCS 1/4-20 x 3/4
4..	539 103295....	1....	BUSHING, IDLER	22..	510 126701....	2....	LATCH, SHORT WING
5..	539 103257....	1....	PULLEY, IDLER	23..	539 130391....	1....	ARM, IDLER, W/BEARINGS
6..	539 103303....	1....	PAD, PAINTED	24..	539 130235....	1....	RHSNB 3/8-16 x 2 3/4
7..	505 290102....	1....	COVER, BELT, 36	25..	510 254501....	1....	SHIELD, DUST
8..	539 990517....	4....	WASHER 3/8 FLAT	26..	539 107042....	1....	HCS 3/8-16 x 1 1/2 GR 8
9..	539 976979....	9....	NUT 3/8-16 HEX NYLOC	27..	539 109332....	1....	NUT 3/8-16 HEX JAM
10..	539 108507....	8....	HCS 3/8-16 x 7/8	28..	539 990613....	1....	NUT 3/8-16 HEX WHIZLK
11..	539 101341....	1....	HCS 3/8-16 x 3	29..	539 130242....	1....	BUSHING, IDLER
12..	539 110655....	1....	SPRING	30..	539 103433....	1....	HCS 1/2-13 x 3 1/4
13..	539 108450....	1....	DUST CAP, TOP	31..	510 206301....	1....	PIVOT, BEARING
14..	539 111897....	2....	WASHER, 3/8 SPECIAL	32..	539 102243....	1....	WASHER, SUPPORT
15..	505 247401....	1....	BELT, DECK 36	33..	522 023401....	1....	WASHER, THICK 3/8
16..	505 290402....	2....	WEDGE	34..	539 101331....	1....	NUT 1/2 HEX NYLOC
17..	539 110813....	2....	RETAINER 1/4-20 "U" TYPE	35..	539 115528....	1....	WASHER, BELLEVILLE 1/2
18..	539 132581....	2....	HINGE, BIN				

36" MOWER DECK

Lower Deck

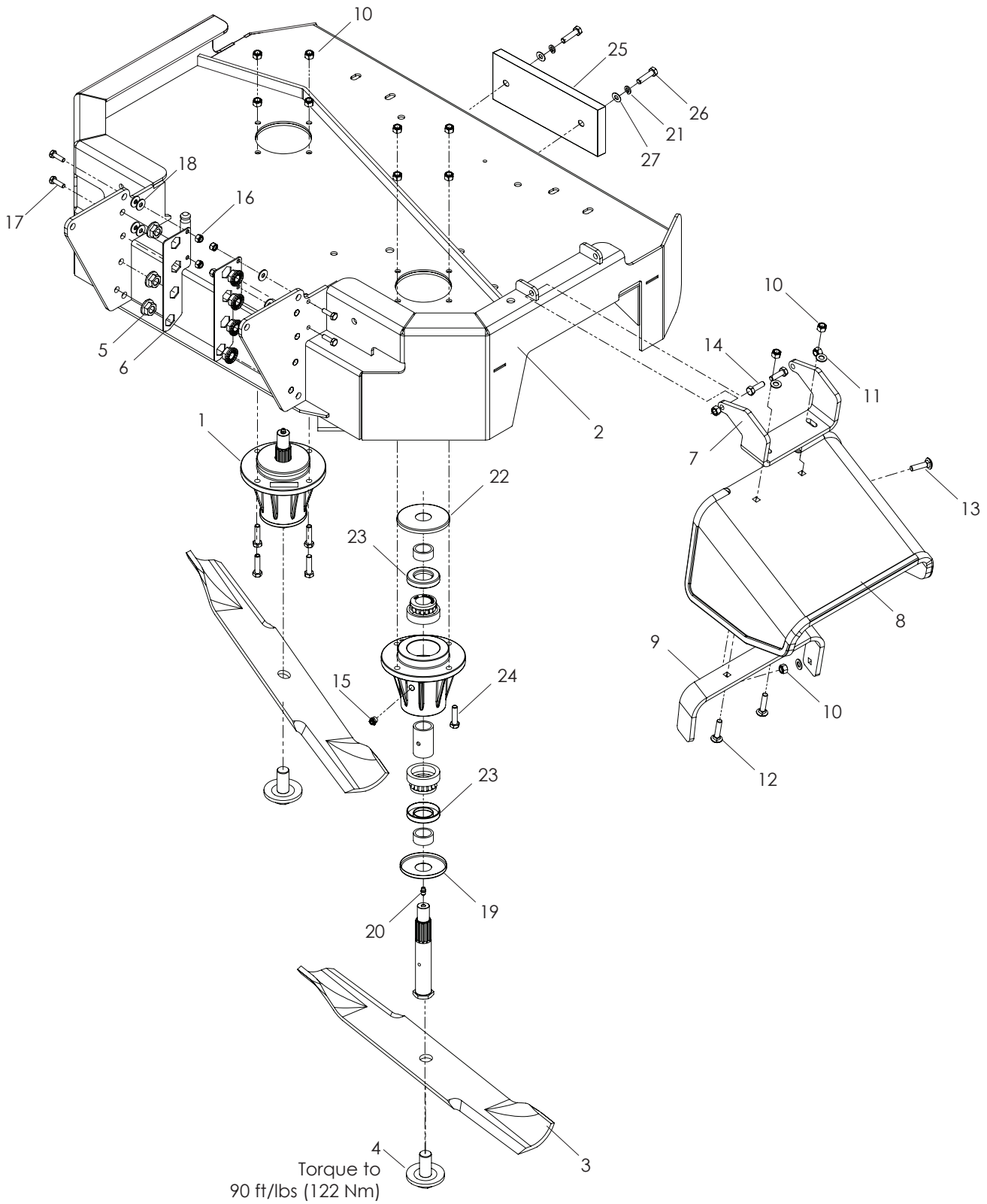

36" MOWER DECK

ITEM	PART NO.	QTY.	DESCRIPTION	ITEM	PART NO.	QTY.	DESCRIPTION
1..	539 131385....	2....	SPINDLE ASSEM	15..	539 977326....	1....	GREASE POPPET
2..	522 478201....	1....	DECK W DECALS, 36"	16..	539 976978....	4....	NUT ¼-20 HEX NYLOC
3..	539 100341....	2....	BLADE, 18"	17..	539 990643....	4....	HCS ¼-20 x 7/8
4..	539 119007....	2....	BOLT, BLADE	18..	539 990598....	8....	WASHER ¼ FLAT
5..	506 113501....	7....	NUT, FLANGE, ½-13	19..	539 108449....	1....	DUST CAP, BOTTOM
6..	539 132592....	2....	NUT, PLATE	20..	539 101474....	1....	ZERK
7..	539 132583....	1....	HINGE, CHUTE	21..	539 990254....	4....	WASHER ½ SLW
8..	539 130903....	1....	RUBBER CHUTE	22..	539 108450....	2....	DUST CAP, TOP
9..	539 130922....	1....	REINFORCEMENT, BRKT	23..	539 108754....	2....	SEAL, SHAFT
10..	539 990717..	13....	NUT 5/16-18 HEX NYLOC	24..	539 990627....	8....	HCS 5/16-18 x 1¼
11..	539 990188....	3....	WASHER 5/16 SAE FLAT	25..	522 000502....	2....	WEIGHT, COUNTER
12..	539 102933....	2....	RHSNB 5/16-18 x 1½	26..	539 108374....	4....	HCS ½-13 x 1½
13..	539 100472....	1....	RHSNB 5/16-18 x 1¼	27..	539 990250....	4....	WASHER ½ SAE FLAT
14..	539 990209....	2....	HCS 5/16-18 x 1				

48" MOWER DECK

Upper Deck

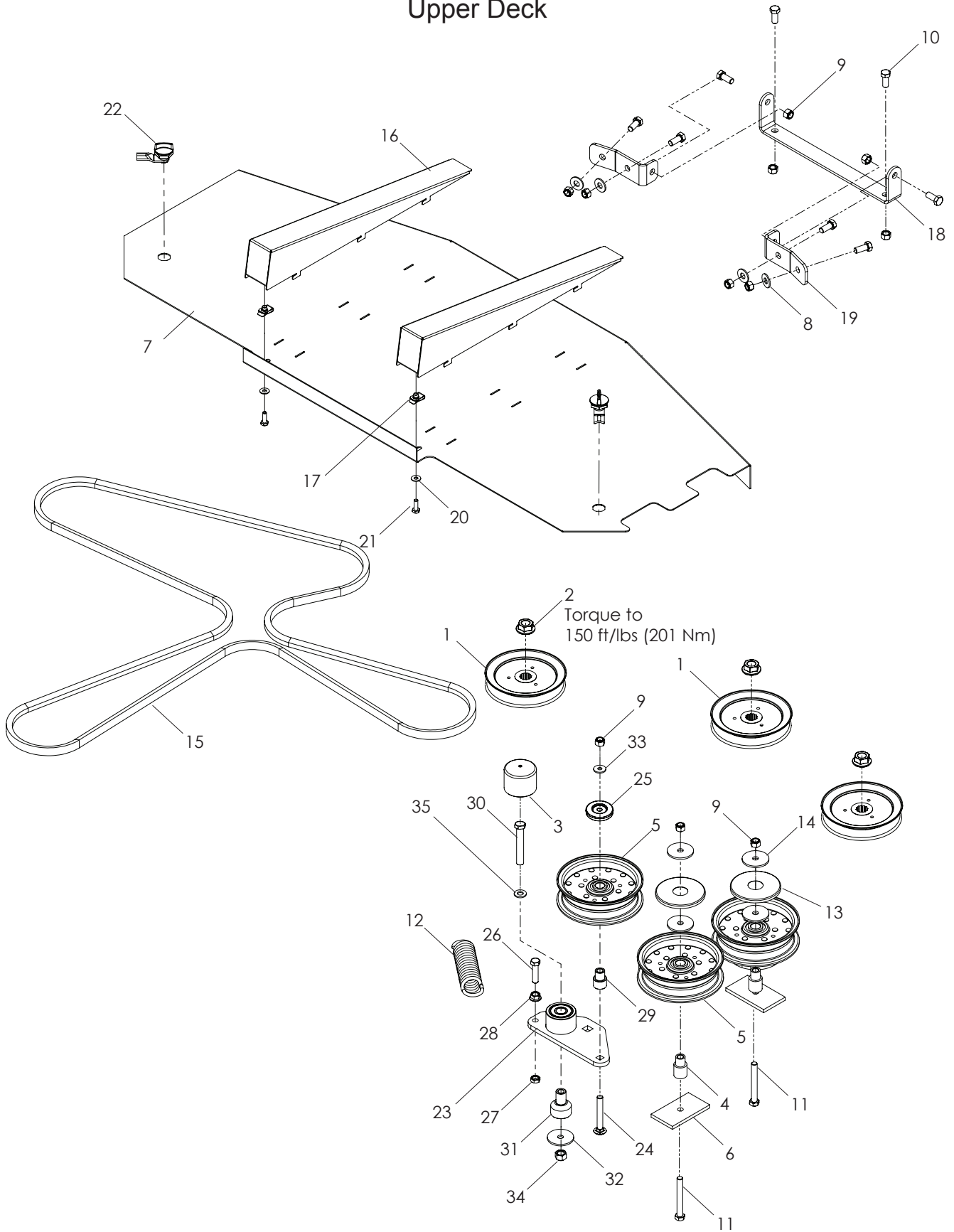

48" MOWER DECK

ITEM	PART NO.	QTY.	DESCRIPTION	ITEM	PART NO.	QTY.	DESCRIPTION
1..	522 023701....	3....	PULLEY	19..	539 132579....	1....	BASE, HINGE
2..	539 130653....	3....	NUT 3/4-16 FLANGE	20..	539 990055....	2....	WASHER, 1/4 FLAT SAE
3..	539 114823....	1....	CAP, VINYL	21..	539 990580....	2....	HCS 1/4-20 x 3/4
4..	539 103295....	1....	BUSHING, IDLER	22..	510 126701....	2....	LATCH, SHORT WING
5..	539 103257....	1....	PULLEY, IDLER	23..	539 130391....	1....	ARM, IDLER, W/BEARINGS
6..	539 103303....	2....	PAD, PAINTED	24..	539 130235....	1....	RHSNB 3/8-16 x 2 3/4
7..	505 290202....	1....	COVER, BELT, 48	25..	510 254501....	1....	SHIELD, DUST
8..	539 990517....	4....	WASHER 3/8 FLAT	26..	539 107042....	1....	HCS 3/8-16 x 1 1/2 GR 8
9..	539 976979..	18....	NUT 3/8-16 HEX NYLOC	27..	539 109332....	1....	NUT 3/8-16 HEX JAM
10..	539 108507..	16....	HCS 3/8-16 x 7/8	28..	539 990613....	1....	NUT 3/8-16 HEX WHIZLK
11..	539 101341....	2....	HCS 3/8-16 x 3	29..	539 130242....	1....	BUSHING, IDLER
12..	539 110655....	1....	SPRING	30..	539 103433....	1....	HCS 1/2-13 x 3 1/4
13..	539 108450....	2....	DUST CAP, TOP	31..	510 206301....	1....	PIVOT, BEARING
14..	539 111897....	4....	WASHER, 3/8 SPECIAL	32..	539 102243....	1....	WASHER, SUPPORT
15..	539 109244....	1....	BELT, DECK	33..	522 023401....	1....	WASHER, THICK 3/8
16..	505 290402....	2....	WEDGE	34..	539 101331....	1....	NUT 1/2 HEX NYLOC
17..	539 110813....	2....	RETAINER 1/4-20 "U" TYPE	35..	539 115528....	1....	WASHER, BELLEVILLE 1/2
18..	539 132581....	2....	HINGE, BIN				

48" MOWER DECK

ITEM	PART NO.	QTY.	DESCRIPTION	ITEM	PART NO.	QTY.	DESCRIPTION
1..	539 131385....	3....	SPINDLE ASSEM	17..	539 990643....	4....	HCS ¼-20 x 7/8
2..	522 478301....	1....	DECK W DECALS, 48"	18..	539 990598....	8....	WASHER ¼ FLAT
3..	539 100340....	3....	BLADE	19..	539 108754....	6....	SEAL, SHAFT
4..	539 119007....	3....	BOLT, BLADE	20..	539 990254....	4....	WASHER ½ SLW
5..	506 113501....	7....	NUT, FLANGE, ½-13	21..	539 105444....	1....	CENTER BAFFLE
6..	539 132592....	2....	NUT, PLATE	22..	539 990799....	6....	RHSNB 5/16-18 x 5/8
7..	539 132583....	1....	HINGE, CHUTE	23..	539 990692....	2....	WASHER 5/16 STD FLT
8..	539 130903....	1....	RUBBER CHUTE	24..	539 108450....	3....	DUST CAP, TOP
9..	539 130922....	1....	REINFORCEMENT, BRKT	25..	539 990184....	6....	NUT 5/16-18 HEX CTRLK
10..	539 990717..	17....	NUT 5/16-18 HEX NYLOC	26..	539 990627....	8....	HCS 5/16-18 x 1¼
11..	539 990188....	3....	WASHER 5/16 SAE FLAT	27..	510 283202....	1....	MAIN BAFFLE
12..	539 102933....	2....	RHSNB 5/16-18 x 1½	28..	539 108449....	3....	DUST CAP, BOTTOM
13..	539 100472....	1....	RHSNB 5/16-18 x 1¼	29..	522 000502....	2....	WEIGHT, COUNTER
14..	539 990209....	2....	HCS 5/16-18 x 1	30..	539 108374....	4....	HCS ½-13 x 1½
15..	539 101474....	3....	ZERK	31..	539 990250....	4....	WASHER ½ SAE FLAT
16..	539 976978....	4....	NUT ¼-20 HEX NYLOC				

52" MOWER DECK

ITEM	PART NO.	QTY.	DESCRIPTION	ITEM	PART NO.	QTY.	DESCRIPTION
1..	522 023801....	3....	PULLEY	19..	539 132579....	1....	BASE, HINGE
2..	539 130653....	3....	NUT 3/4-16 FLANGE	20..	539 990055....	2....	WASHER, 1/4 FLAT SAE
3..	522 023401....	1....	WASHER, THICK 3/8	21..	539 990580....	2....	HCS 1/4-20 x 3/4
4..	539 103295....	1....	BUSHING, IDLER	22..	510 126701....	2....	LATCH, SHORT WING
5..	539 103257....	1....	PULLEY, IDLER	23..	539 130391....	1....	ARM, IDLER, W/BEARINGS
6..	539 103303....	2....	PAD, PAINTED	24..	539 130235....	1....	RHSNB 3/8-16 x 2 3/4
7..	505 290302....	1....	COVER, BELT, 52	25..	539 103433....	1....	HCS 1/2-13 x 3 1/4
8..	539 990517....	4....	WASHER 3/8 FLAT	26..	539 107042....	1....	HCS 3/8-16 x 1 1/2 GR 8
9..	539 976979..	10....	NUT 3/8-16 HEX NYLOC	27..	539 109332....	1....	NUT 3/8-16 HEX JAM
10..	539 108507....	8....	HCS 3/8-16 x 7/8	28..	539 990613....	1....	NUT 3/8-16 HEX WHIZLK
11..	539 101341....	2....	HCS 3/8-16 x 3	29..	539 130242....	1....	BUSHING, IDLER
12..	539 130690....	1....	SPRING	30..	539 102243....	1....	WASHER, SUPPORT
13..	539 108450....	2....	DUST CAP, TOP	31..	510 206301....	1....	PIVOT, BEARING
14..	539 111897....	4....	WASHER, 3/8 SPECIAL	32..	539 114823....	1....	CAP, VINYL
15..	539 116424....	1....	BELT, DECK 52	33..	539 101331....	1....	NUT 1/2 HEX NYLOC
16..	505 290402....	2....	WEDGE	34..	539 115528....	1....	WASHER, BELLEVILLE 1/2
17..	539 110813....	2....	RETAINER 1/4-20 "U" TYPE	35..	510 254501....	1....	SHIELD, DUST
18..	539 132581....	2....	HINGE, BIN				

52" MOWER DECK

Lower Deck

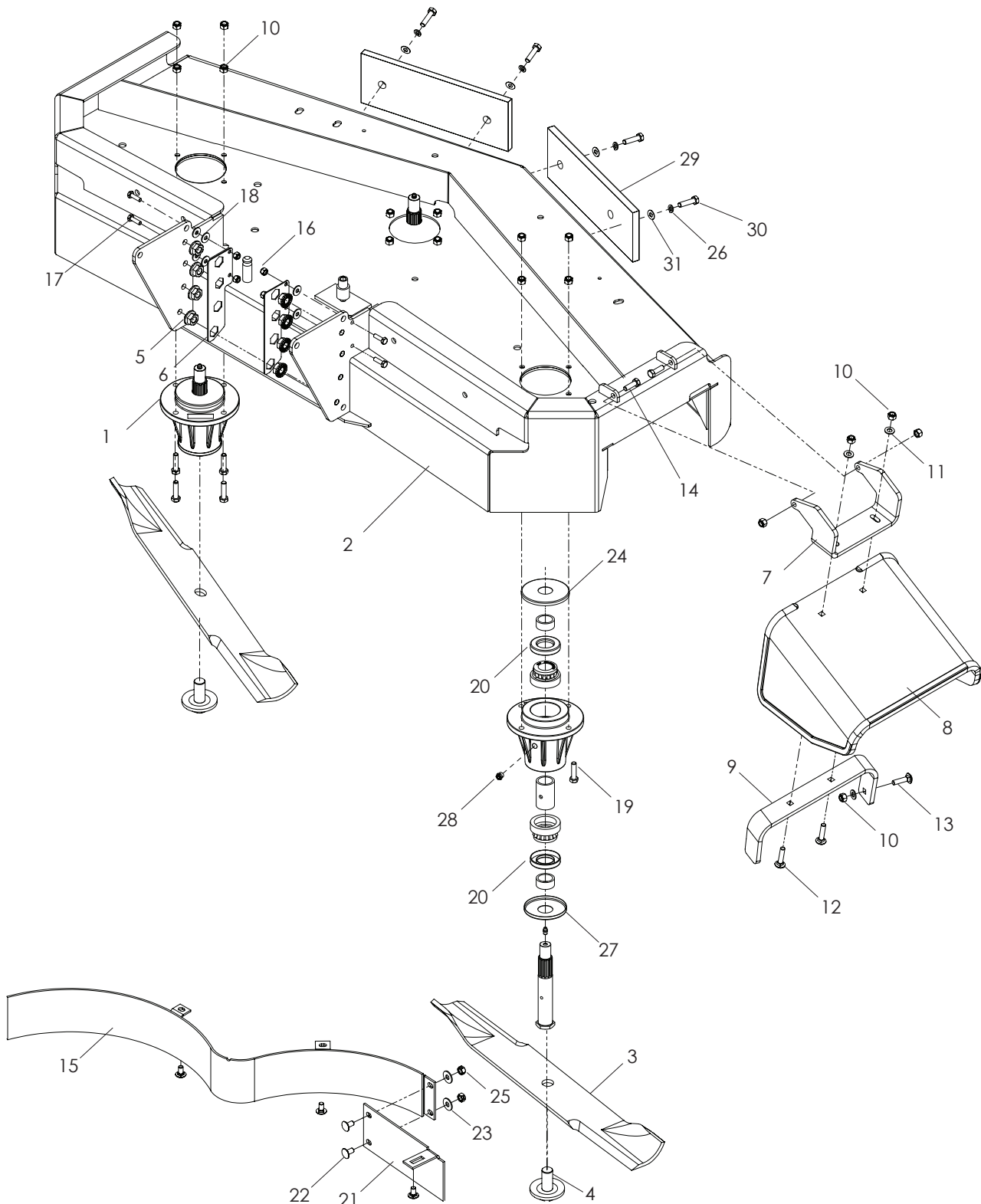

Torque to
90 ft/lbs (122 Nm)

52" MOWER DECK

ITEM	PART NO.	QTY.	DESCRIPTION	ITEM	PART NO.	QTY.	DESCRIPTION
1..	539 131385....	3....	SPINDLE ASSEM	17..	539 990643....	4....	HCS ¼-20 x 7/8
2..	522 478401....	1....	DECK W DECALS, 52"	18..	539 990598....	8....	WASHER ¼ FLAT
3..	539 100341....	3....	BLADE	19..	539 990627..	12....	HCS 5/16-18 x 1¼
4..	539 119007....	3....	BOLT, BLADE	20..	539 108754....	6....	SEAL, SHAFT
5..	506 113501....	7....	NUT, FLANGE, ½-13	21..	539 105453....	1....	CENTER BAFFLE
6..	539 132592....	2....	NUT, PLATE	22..	539 990799....	5....	RHSNB 5/16-18 x 5/8
7..	539 132583....	1....	HINGE, CHUTE	23..	539 990692....	2....	WASHER 5/16 STD FLT
8..	539 130903....	1....	RUBBER CHUTE	24..	539 108450....	3....	DUST CAP, TOP
9..	539 130922....	1....	REINFORCEMENT, BRKT	25..	539 990184....	5....	NUT 5/16-18 HEX CTRLK
10..	539 990717..	17....	NUT 5/16-18 HEX NYLOC	26..	539 990254....	4....	WASHER ½ SLW
11..	539 990188....	3....	WASHER 5/16 SAE FLAT	27..	539 108449....	3....	DUST CAP, BOTTOM
12..	539 102933....	2....	RHSNB 5/16-18 x 1½	28..	539 101474....	3....	ZERK
13..	539 100472....	1....	RHSNB 5/16-18 x 1¼	29..	522 000502....	2....	WEIGHT, COUNTER
14..	539 990209....	2....	HCS 5/16-18 x 1	30..	539 108374....	4....	HCS ½-13 x 1½
15..	539 105457....	1....	MAIN BAFFLE	31..	539 990250....	4....	WASHER ½ SAE FLAT
16..	539 976978....	4....	NUT ¼-20 HEX NYLOC				

DECALS

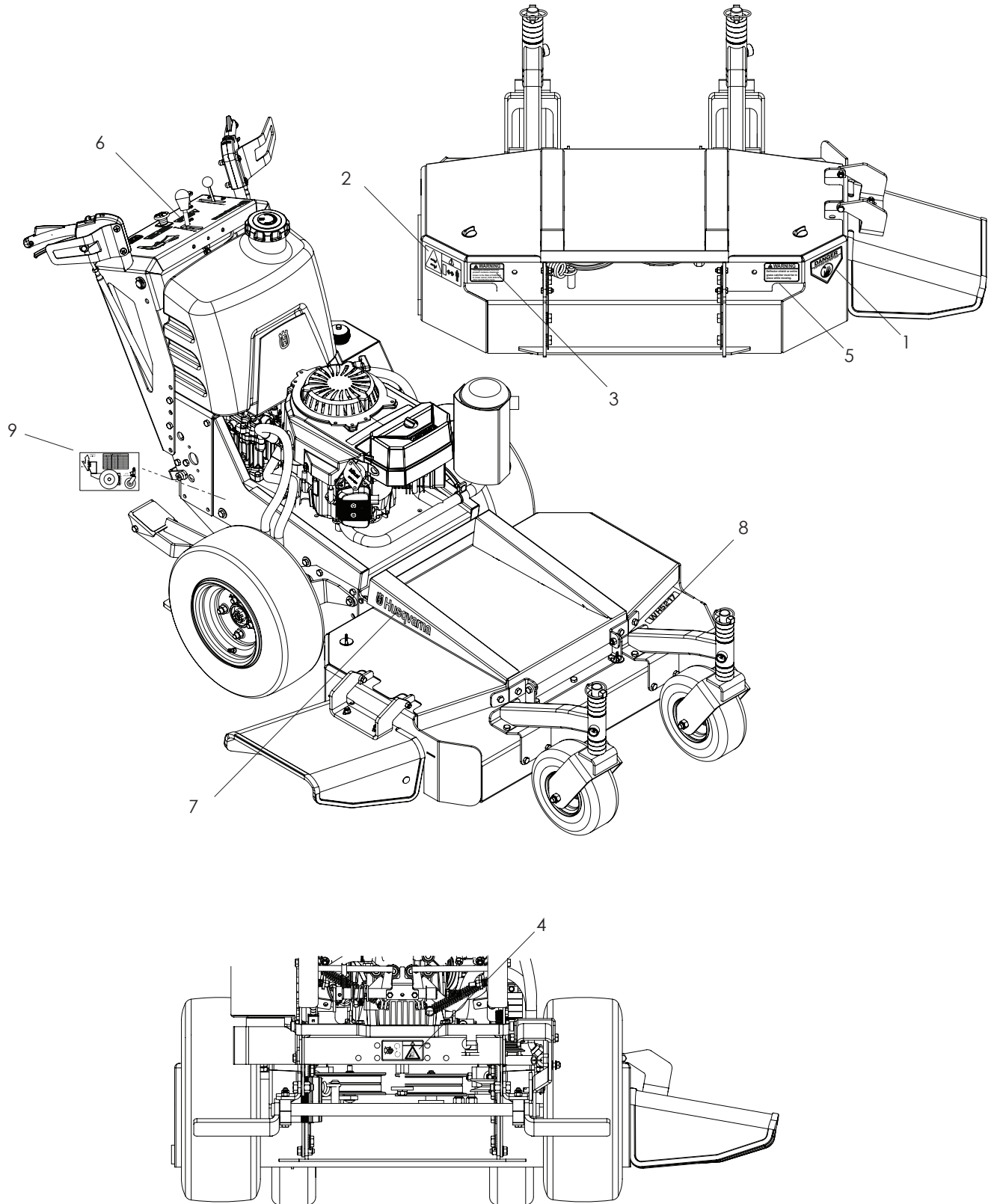

DECALS

ITEM	PART NO.	QTY.	DESCRIPTION	ITEM	PART NO.	QTY.	DESCRIPTION
1..	539 913010....	1....	DECAL, WARNING	7..	532 422012....	2....	DECAL, HUSQVARNA
2..	539 105746....	1....	DECAL, SEVERING	8..	532 422011....	1....	DECAL, CROWN
3..	539 101881....	1....	DECAL, PROP 65	9..	521 933701....	1....	DECAL, HEIGHT OF CUT
4..	539 105744....	1....	DECAL, BELT DRIVES	10..	520 282101....	1....	DECAL, WH5217
5..	539 113224....	1....	DECAL, WARNING		520 282301....	1....	DECAL, WH4817
6..	520 282601....	1....	DECAL, INSTRUMENT PNL		520 282201....	1....	DECAL, WH3615

