

GTH2648

Illustrated Parts List / 96043003001 / 2008-01

**TRACTOR - MODEL NO. GTH2648 (96043003001), PRODUCT NO. 960 43 00-30
DECALS**

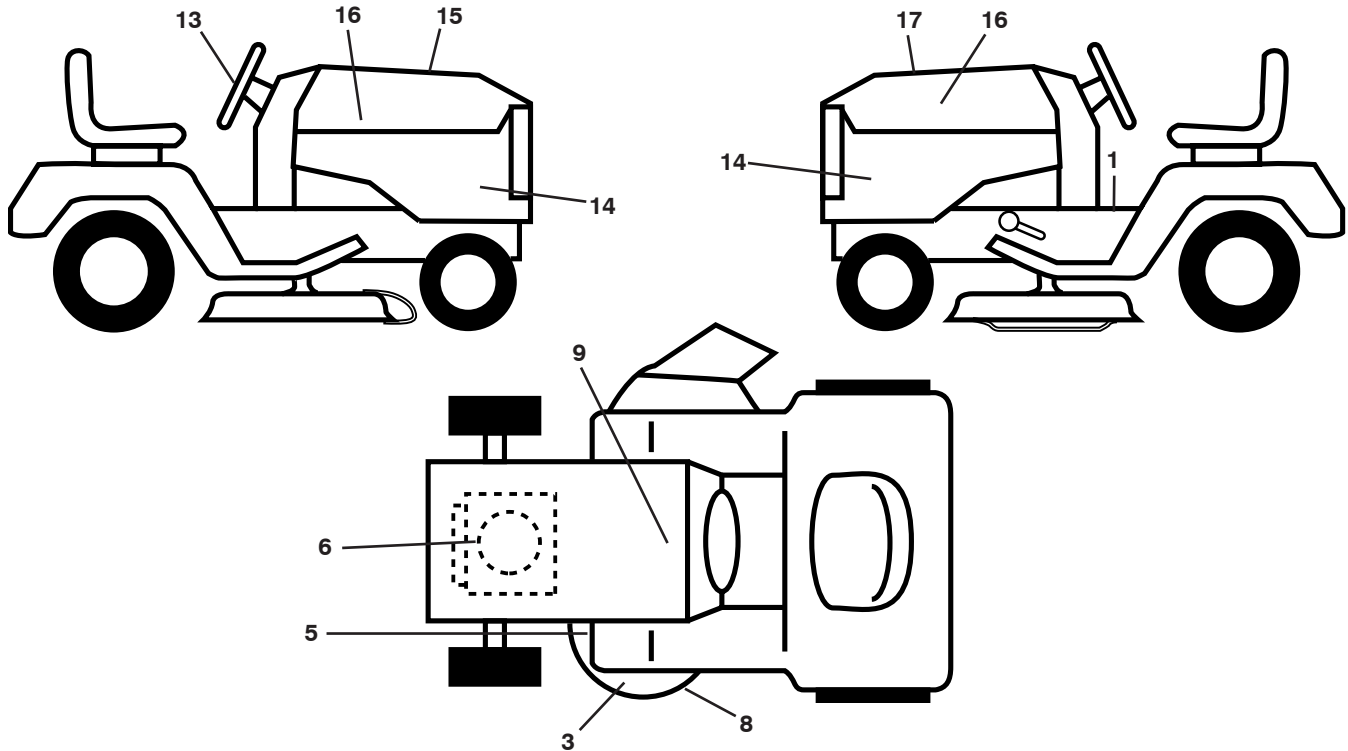

KEY NO.	PART NO.	DESCRIPTION
1	532 41 16-58	Decal, Fender Warning
3	532 17 05-63	Decal, Warning
5	532 17 85-02	Decal, Caution
6	532 40 88-43	Decal, Eng. HP
8	532 19 87-85	Decal, Mower Sch.
9	532 14 50-05	Decal, Battery Dnge/Poi
13	532 40 44-84	Decal, Steering Whl
14	532 41 06-64	Decal, Panel Side

KEY NO.	PART NO.	DESCRIPTION
15	532 18 09-41	Decal, Cust. Resp.
16	532 41 68-38	Decal, Hood Logo
17	532 40 84-64	Decal, Replacement
--	532 16 69-60	Decal, Bypass
--	532 40 17-71	Pad, Footrest, LH
--	532 40 17-70	Pad, Footrest, RH

WHEELS AND TIRES

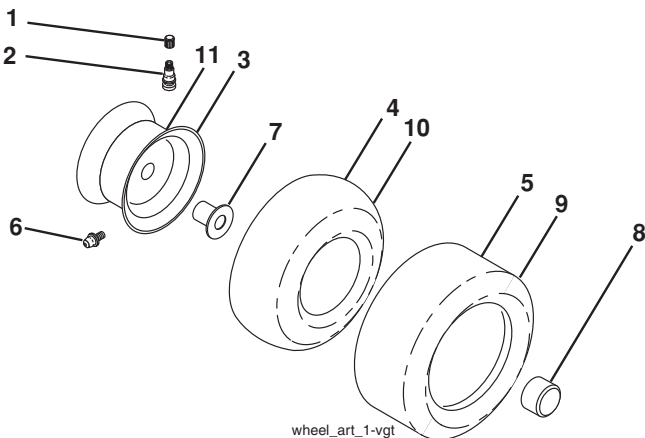

KEY NO.	PART NO.	DESCRIPTION
1	532 05 91-92	Cap, Valve, Tire
2	532 06 51-39	Stem, Valve
3	532 14 45-09	Rim Assembly, Front
4	532 00 81-34	Tube, Front (Service Item Only)
5	532 10 62-30	Tire, Front
6	532 12 49-57	Fitting, Grease (Front Wheel Only)
7	532 12 49-59	Bearing, Flange (Front Wheel Only)
8	532 17 50-39	Cap, Axle (Front Wheel Only)
9	532 10 55-88	Tire, Rear
10	532 12 49-26	Tube, Rear (Service Item Only)
11	532 14 45-10	Rim Assembly, Rear
--	532 14 43-34	Sealant, Tire (10 oz. Tube)

NOTE: All component dimensions given in U.S. inches
1 inch = 25.4 mm

TRACTOR - MODEL NO. GTH2648 (96043003001), PRODUCT NO. 960 43 00-30 SCHEMATIC

SCH12

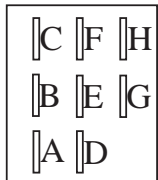
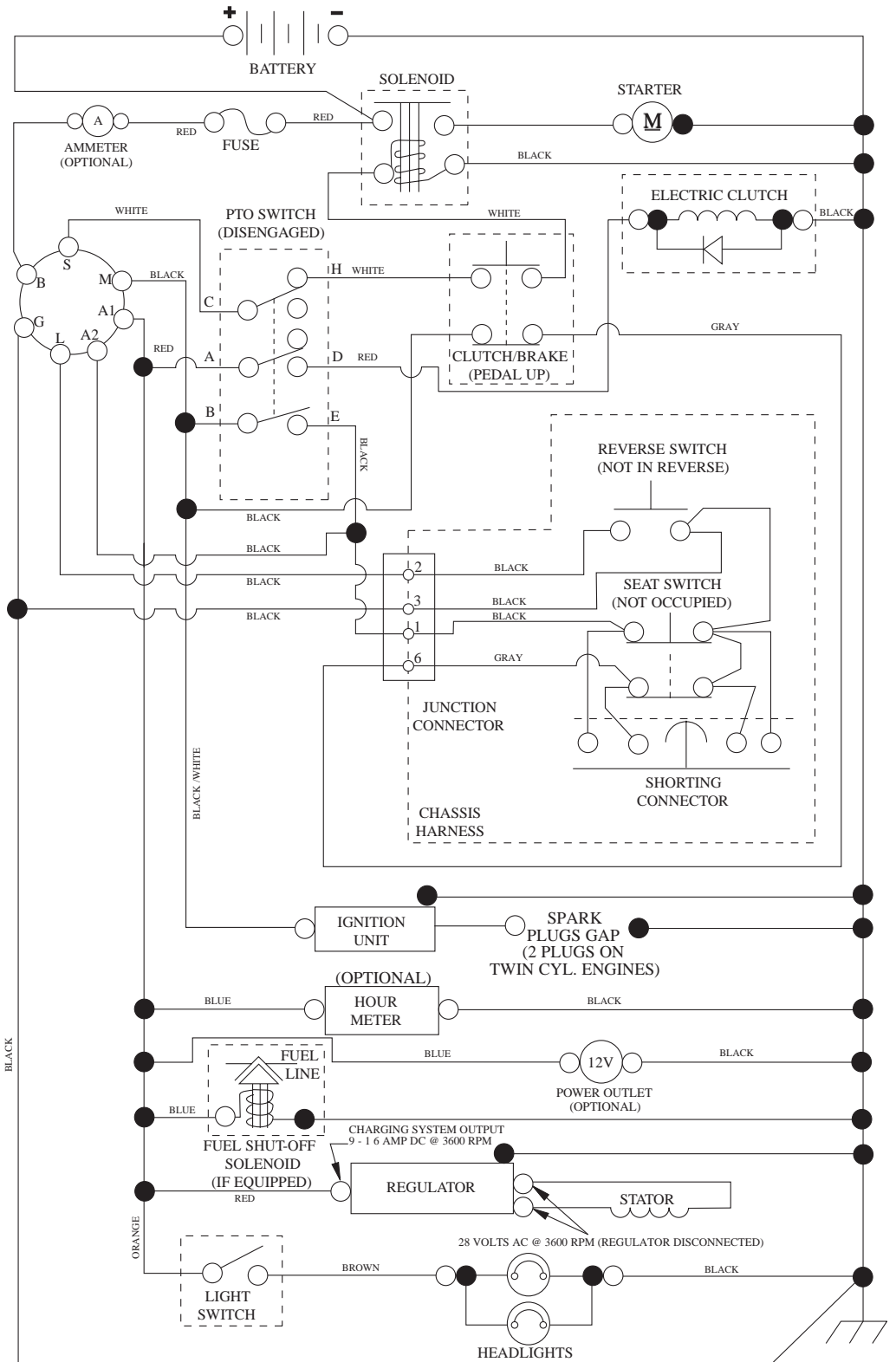

PTO SWITCH
(MATING SIDE)

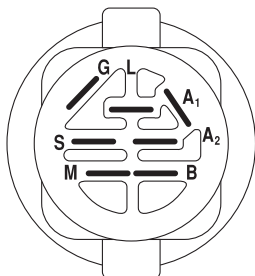

IGNITION SWITCH

POSITION	CIRCUIT "MAKE"
OFF	M+G+A1
RUN/OVERRIDE	B+A1
RUN	B+A1 L+A2
START	B + S + A1

BLACK



CHASSIS HARNESS
CONNECTOR
(MATING SIDE)

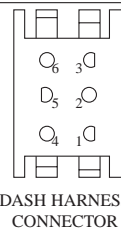

DASH HARNESS
CONNECTOR

WIRING INSULATED CLIPS
NOTE: IF WIRING INSULATED
CLIPS WERE REMOVED FOR
SERVICING OF UNIT, THEY
SHOULD BE RE-INSTALLED TO
PROPERLY SECURE YOUR
WIRING.

●
NON-REMOVABLE
CONNECTIONS

○
REMOVABLE
CONNECTIONS

**TRACTOR - MODEL NO. GTH2648 (96043003001), PRODUCT NO. 960 43 00-30
ELECTRICAL**

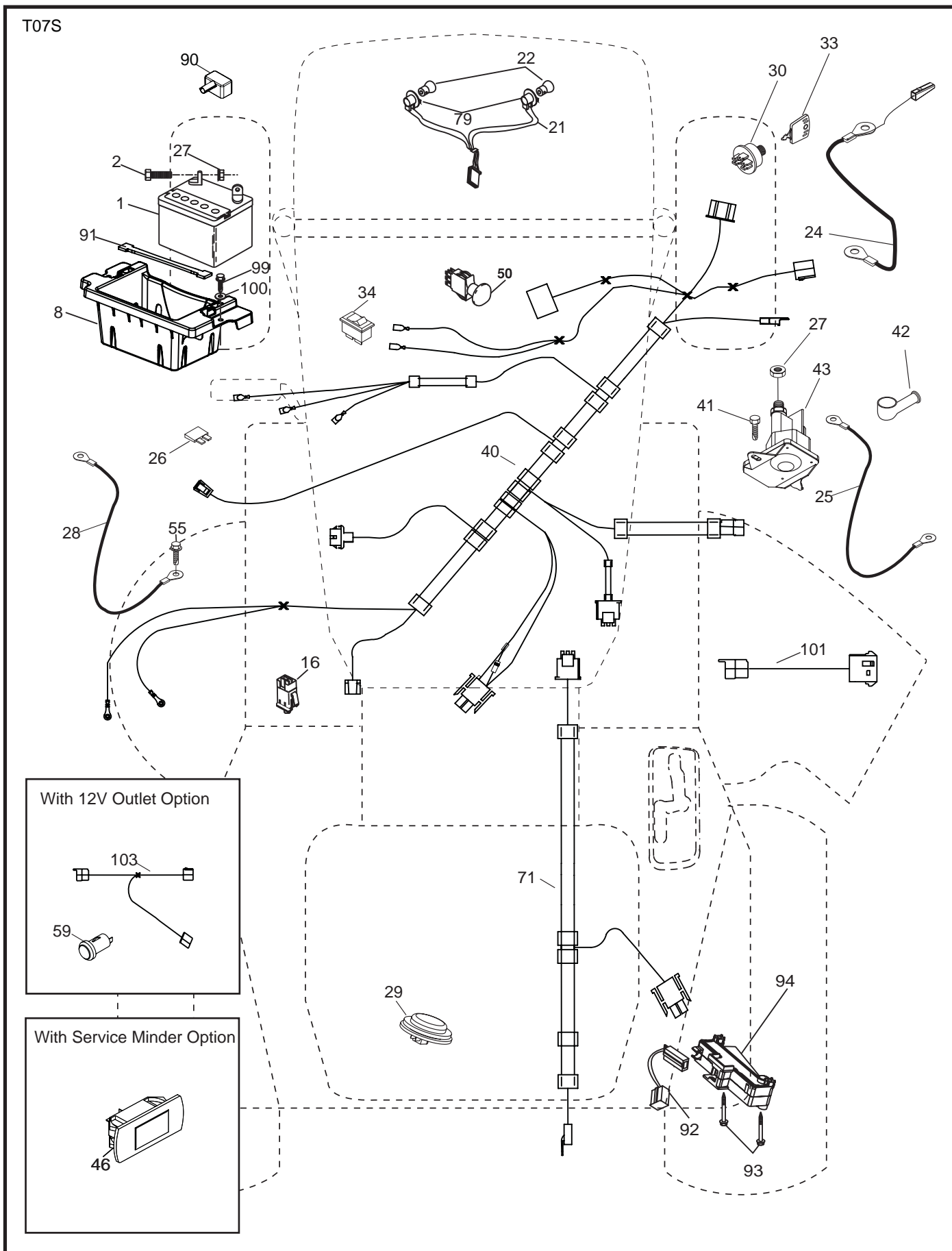

**TRACTOR - MODEL NO. GTH2648 (96043003001), PRODUCT NO. 960 43 00-30
ELECTRICAL**

KEY NO.	PART NO.	DESCRIPTION
1	532 14 49-27	Battery
2	874 76 04-12	Bolt Hex Hd 1/4-20 unc x 3/4
8	532 18 64-91	Battery Box
16	532 17 61-38	Switch Interlock
21	532 18 37-59	Harness Socket Light
22	532 00 41-52	Bulb, Light # 1156
24	532 40 02-53	Cable Battery
25	532 41 28-95	Cable Starter
26	532 17 51-58	Fuse
27	873 51 04-00	Nut Keps Hex 1/4-20 unc
28	532 14 54-91	Cable Ground 21" Blk 6 Ga.
29	532 40 15-45	Switch Seat
30	532 19 33-50	Switch Ign
33	532 41 19-35	Key/Chain
34	532 11 07-12	Switch Light/Reset
40	532 40 11-04	Harness Ign. Dash
41	817 72 04-08	Screw Thd Cut 1/4-20 x 1/2
42	532 13 15-63	Cover Terminal Red
43	532 19 25-07	Solenoid
46	532 40 17-63	Gauge Hourmeter
50	532 17 46-51	Switch PTO
55	817 06 05-12	Screw Thdrol 5/16-18 x 3/4
59	532 40 03-03	Outlet 12-Volt
71	532 19 42-76	Harness Chassis
79	532 17 52-42	Socket Asm. Bulb Twistlock
90	532 40 07-24	Cover Terminal Battery
91	532 19 02-70	Strap Battery
92	532 19 66-15	Harness Pigtail Console ROS
93	532 19 25-40	Screw Plastite 10-14 x 2.0
94	532 19 18-34	Module Reverse ROS
99	817 67 04-12	Screw Hexwsh Thdrol 1/4-20 x 3/4
100	819 09 14-16	Washer 9/32 x 7/8 x 16 Ga.
102	532 19 83-17	Pigtail MATNLK Harness
103	532 40 79-62	Harness Pigtail 12v Outlet

NOTE: All component dimensions given in U.S. inches
1 inch = 25.4 mm

**TRACTOR - MODEL NO. GTH2648 (96043003001), PRODUCT NO. 960 43 00-30
CHASSIS**

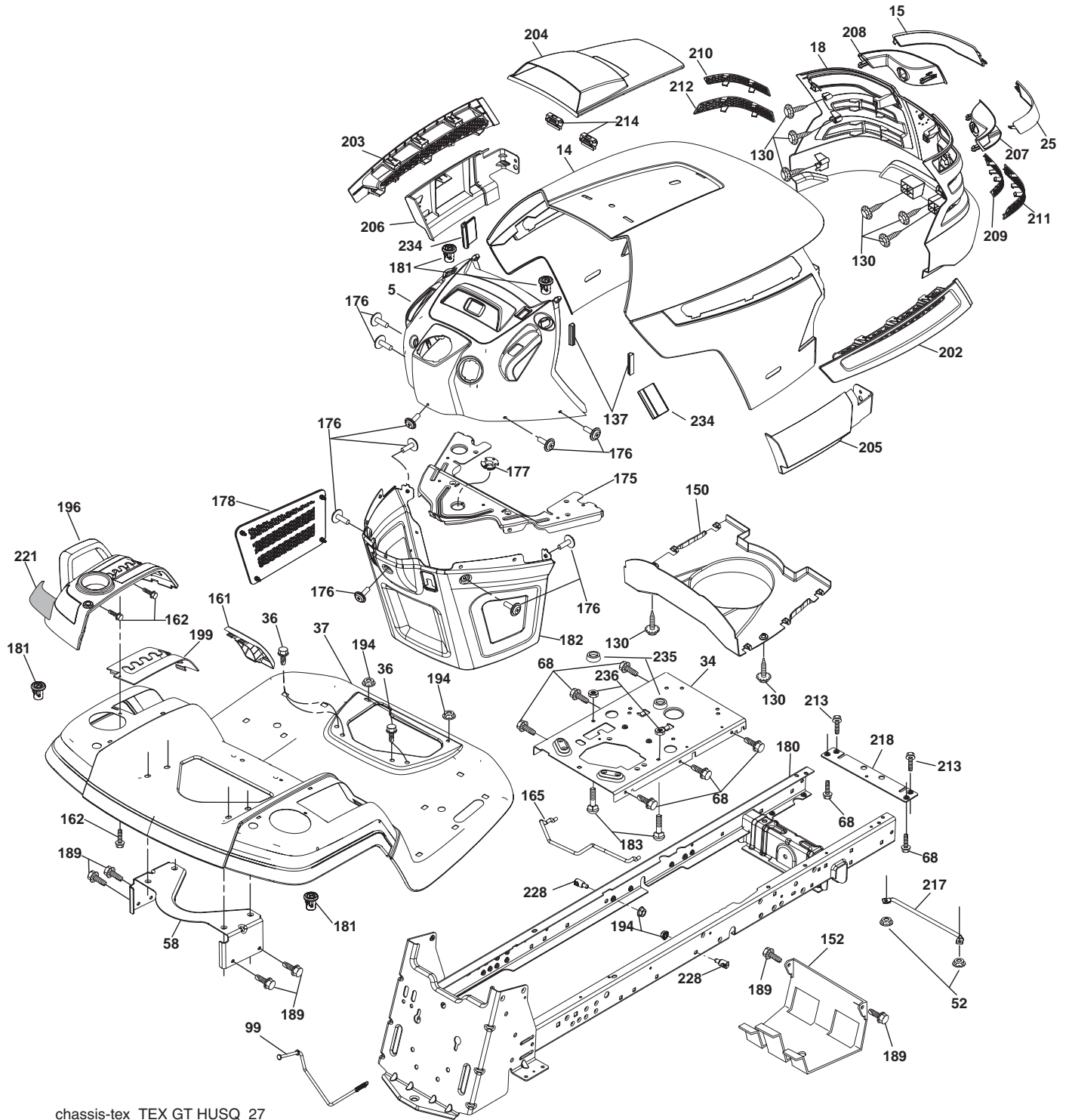

chassis-tex_TEX GT HUSQ_27

**TRACTOR - MODEL NO. GTH2648 (96043003001), PRODUCT NO. 960 43 00-30
CHASSIS**

KEY NO.	PART NO.	DESCRIPTION
5	532 40 87-01	Dash
14	532 41 10-46	Hood
15	532 19 89-07	Lens LH
18	532 40 86-07	Grille Asm.
25	532 19 89-06	Lens RH
34	532 19 61-25	Plate Engine
36	817 06 05-12	Screw 5/16-18 x 3/4
37	532 40 18-25	Fender
52	873 68 05-00	Nut Crown Lock 5/16-18
58	532 19 43-14	Bracket Fender
68	817 49 05-08	Screw 5/16-18 x 1/2
99	532 19 72-73	Rod Bypass Asm.
130	532 41 63-58	Screw #10 x .750 BOS Thread
137	532 40 75-90	Bumper Dash
150	532 19 85-12	Duct Heat Hood
152	532 19 95-35	Shield Browning/Debris
161	532 40 18-26	Console Fuel Window
162	532 14 24-32	Screw Hex Wsh Hi-Lo 1/4 x 1/2
165	532 19 68-26	Bracket Support Tank
175	532 19 63-04	Crossmember
176	532 40 07-76	Screw 10-24 x 5/8 Wshd Qdrx
177	532 19 52-27	Bushing Steering
178	532 19 97-82	Cargo Asm. Net
180	532 19 54-77	Chassis
181	532 40 30-25	Bushing Mtg. Fender Crgo.
182	532 40 68-59	Dash Lower
183	874 78 05-20	Bolt Fin Hex 5/16-18 unc x 1-1/4

KEY NO.	PART NO.	DESCRIPTION
189	817 00 05-12	Screw 5/16-18 x 3/4
194	873 90 05-00	Nut Lock Hex Flange 5/16-18
196	532 40 02-99	Console Asm. Deck Lift
199	532 19 82-59	Plate Deck Lift
202	532 40 30-48	Vent Side Hood RH
203	532 40 30-76	Vent Side Hood LH
204	532 41 66-15	Vent Asm Hood Top
205	532 40 17-09	Skirt Hood Side RH
206	532 40 17-11	Skirt Hood Side LH
207	532 19 71-98	Bezel RH
208	532 19 71-99	Bezel LH
209	532 19 91-30	Insert Hex Top RH
210	532 19 91-31	Insert Hex Top LH
211	532 19 91-32	Insert Hex Bottom RH
212	532 19 91-33	Insert Hex Bottom LH
213	874 76 05-12	Bolt Hex Hd 5/16-18 unc x 3/4
214	532 19 91-45	Clip Retainer
217	532 40 91-67	Rod Pivot
218	532 19 63-95	Hood Stop
221	532 19 89-09	Reflector LH
228	532 19 51-61	Stud Fastener
234	532 40 47-42	Bumper Hood
235	532 40 61-29	Spacer Fender
236	873 93 05-00	Nut Center Lock 5/16-18 unc

NOTE: All component dimensions given in U.S. inches
1 inch = 25.4 mm

**TRACTOR - MODEL NO. GTH2648 (96043003001), PRODUCT NO. 960 43 00-30
DRIVE**

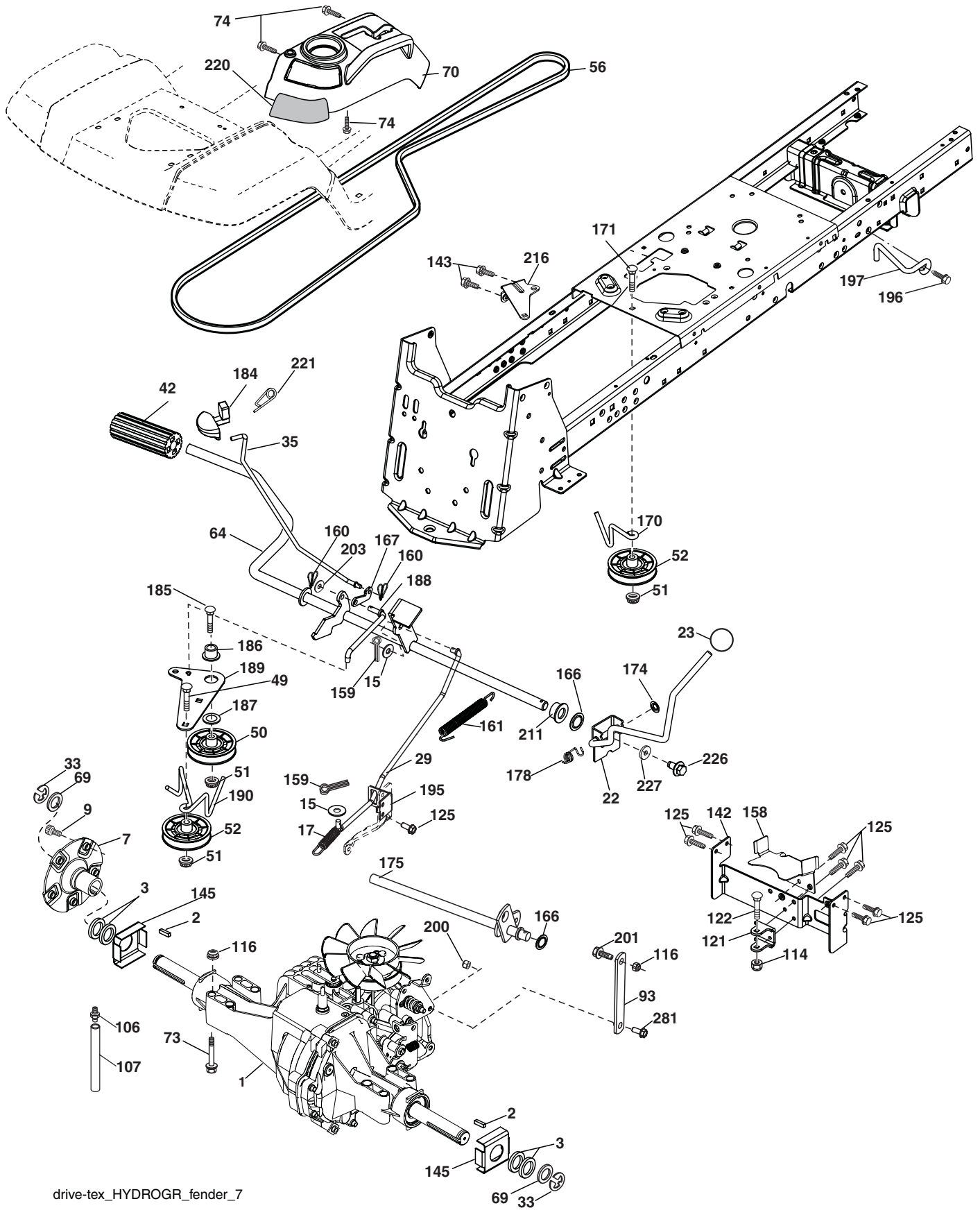

drive-tex_HYDROGR_fender_7

**TRACTOR - MODEL NO. GTH2648 (96043003001), PRODUCT NO. 960 43 00-30
DRIVE**

KEY NO.	PART NO.	DESCRIPTION
1	-----	Transaxle, Hydro 344-3000 (Order Parts from Transaxle Manufacturer)
2	532 00 70-70	Key 1/4 x 2.5
3	532 00 75-63	Washer
7	532 19 98-37	Hub Asm. Wheel
9	532 14 00-80	Bolt Hub Wheel
15	819 13 13-16	Washer 13/32 x 13/16 x 16 Ga.
17	532 19 72-96	Spring, Brake
22	532 40 05-04	Shifter Rod
23	532 14 08-45	Knob
29	532 19 72-69	Rod, Brake
33	812 00 00-53	Ring E
35	532 19 95-91	Rod, Brake, Park
42	532 12 48-72	Cover, Foot Pedal
49	872 11 06-14	Bolt
50	532 19 43-27	Pulley Idler Flat
51	873 90 06-00	Lock Nut 3/8-16
52	532 19 43-26	Idler V-Groove 910" Offset
56	532 16 58-13	V-Belt, Drive
64	532 19 62-00	Shaft Asm. Pedal Brake Control
69	532 12 38-00	Washer 11/32 x 1-5/8 x 16 Ga.
70	532 40 02-98	Control Asm.
73	874 49 05-48	Bolt Hex Flghd 5/16-18 x 3.00
74	532 14 24-32	Screw 1/4 x 1/2
93	532 19 62-13	Link Shift
106	532 14 29-17	Cap Asm. Vent
107	532 41 04-81	Tube Vent
114	873 80 05-00	Nut Lock Hex w/Insert 5/16-18 unc
116	873 90 05-00	Nut Lock Hex Flange 5/16-18
121	532 17 56-11	Bracket Strap Torque
122	872 01 05-20	Bolt 5/16 - 18 x 2.50
125	817 00 05-12	Screw 5/16-18 x 3/4
142	532 40 44-83	Strap Torque
143	817 49 05-08	Screw Thdrol 5/16-18 x 1/2

KEY NO.	PART NO.	DESCRIPTION
145	532 16 31-68	Washer Axle flange
158	532 19 43-51	Keeper Belt
159	876 02 04-12	Pin Cotter 1/8 x 3/4
160	532 16 94-84	Retainer Clip
161	532 10 57-09	Spring, Return, Clutch
166	532 19 72-90	Nut Push .625
167	532 40 52-57	Latch Brake Parking
170	532 19 43-22	Keeper Belt Centerspan
171	872 11 06-16	Bolt
174	532 19 72-89	Nut Push
175	532 19 62-04	Shaft Asm Shift
178	532 19 74-56	Spring Shift
184	532 40 31-18	Handle Parking Brake
185	872 11 06-20	Bolt Rdhd Sqnk 3/8-16 x 2-1/2
186	532 19 43-21	Spacer Retainer
187	819 13 32-10	Washer
188	532 19 43-23	Link Clutch Ground Drive
189	532 19 43-17	Bellcrank Ground Drive
190	532 19 43-18	Keeper Bellcrank Ground Dr.
195	532 40 51-13	Bracket Rod Brake
196	817 00 06-16	Screw 3/8-16 x 1
197	532 19 97-69	Bracket Clutch Anti-Rotation
200	873 93 05-00	Nut Centerlock 5/16-18
201	532 16 96-12	Bolt Shoulder 5/16-18 unc
203	819 11 11-16	Washer 11/32 x 11/16 x 16 Ga.
211	532 19 62-12	Bushing
216	532 19 61-31	Bracket Pulley Idler
220	532 19 89-08	Reflector RH
221	532 40 31-87	Retainer Spring Clip Handle
226	874 78 07-16	Bolt Fin Hex 7/16 - 14 x 1 Gr. 5
227	532 40 52-96	Washer Serrated
281	532 41 15-54	Shoulder Bolt
- -	532 40 35-71	Phone Holder

NOTE: All component dimensions given in U.S. inches
1 inch = 25.4 mm

**TRACTOR - MODEL NO. GTH2648 (96043003001), PRODUCT NO. 960 43 00-30
ENGINE**

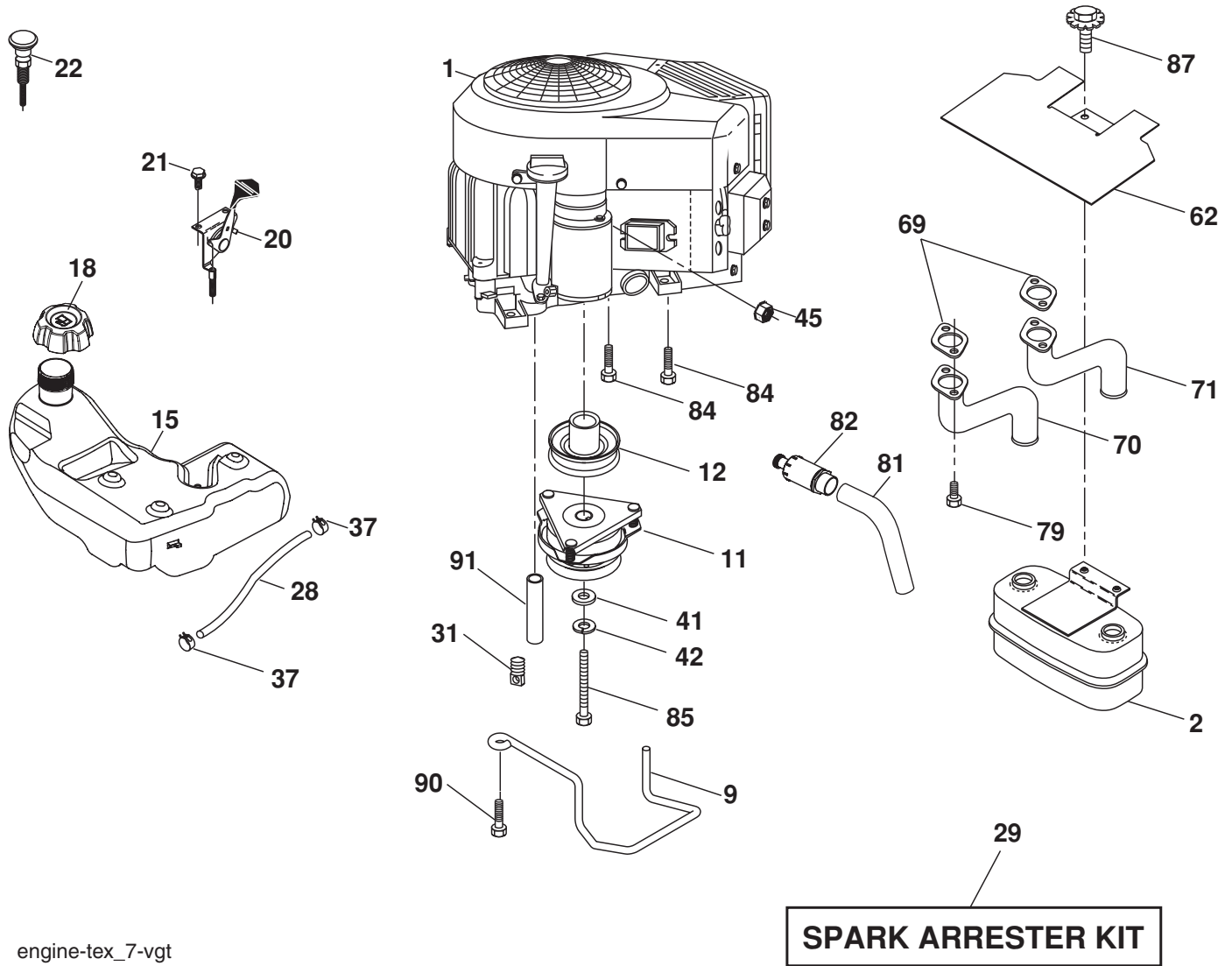

engine-tex_7-vgt

TRACTOR - MODEL NO. GTH2648 (96043003001), PRODUCT NO. 960 43 00-30 ENGINE

KEY NO.	PART NO.	DESCRIPTION
1	-----	Engine Briggs Model No. 445877
2	532 14 97-23	Muffler
9	532 19 43-20	Keeper Belt Engine
11	532 17 93-35	Clutch Electric
12	532 19 43-43	Pulley Engine
15	532 19 34-99	Tank Fuel 4.0
18	532 19 42-67	Cap Asm
20	532 17 83-85	Control Throttle
21	532 41 63-58	Screw #10 x .750 BOS Thread
22	532 19 15-96	Control Choke
28	532 40 11-35	Fuel Line
29	532 13 71-80	Spark Arrester Kit
31	532 14 50-06	Clip Push-In
37	532 12 34-87	Clamp Hose
41	532 12 61-97	Washer 1-1/2 OD x 15/32 ID x .250
42	810 04 07-00	Washer Lock 7/16
45	873 51 04-00	Nut Keps Hex 1/4-20 unc
62	532 14 66-29	Shield Heat Muffler

KEY NO.	PART NO.	DESCRIPTION
69	532 16 53-91	Gasket
70	532 15 99-55	Tube Exhaust LH
71	532 16 05-89	Tube Exhaust RH
79	532 18 39-06	Screw Socket Head 5/16-18 x 1
81	532 14 84-56	Tube Drain Oil Easy
82	532 18 16-54	Plug Drain Oil
84	817 06 06-20	Screw 3/8-16 x 1-1/4
85	532 17 99-53	Bolt Hex 7/16-20 x 3.75 Gr. 5
87	532 19 82-39	Bolt 5/16-18 unc x 1 w/Sems
90	817 00 06-16	Screw 3/8-16 x 1
91	532 18 74-95	Bushing

NOTE: All component dimensions given in U.S. inches
1 inch = 25.4 mm

For engine service and replacement parts, call the toll free
number for your engine manufacturer listed below:

Briggs & Stratton 1-800-233-3723

Engine Power Rating Information

The gross power rating for individual gas engine models is labeled in accordance with SAE (Society of Automotive Engineers) code J11940 (Small Engine Power & Torque Rating Procedure), and rating performance has been obtained and corrected in accordance with SAE J1995 (Revision 2002-5). Actual gross engine power will be lower and is affected by, among other things, ambient operating conditions and engine-to-engine variability. Given both the wide array of products on which engines are placed and the variety of environmental issues applicable to operating the equipment, the gas engine will not develop the rated gross power when used in a given piece of power equipment (actual "on-site" or net horsepower). This difference is due to a variety of factors including, but not limited to, accessories (air cleaner, exhaust, charging, cooling, carburetor, fuel pump, etc.), application limitations, ambient operating conditions (temperature, humidity, altitude), and engine-to-engine variability. Due to manufacturing and capacity limitations, Briggs & Stratton may substitute an engine of higher rated power for this Series engine.

TRACTOR - MODEL NO. GTH2648 (96043003001), PRODUCT NO. 960 43 00-30
STEERING ASSEMBLY

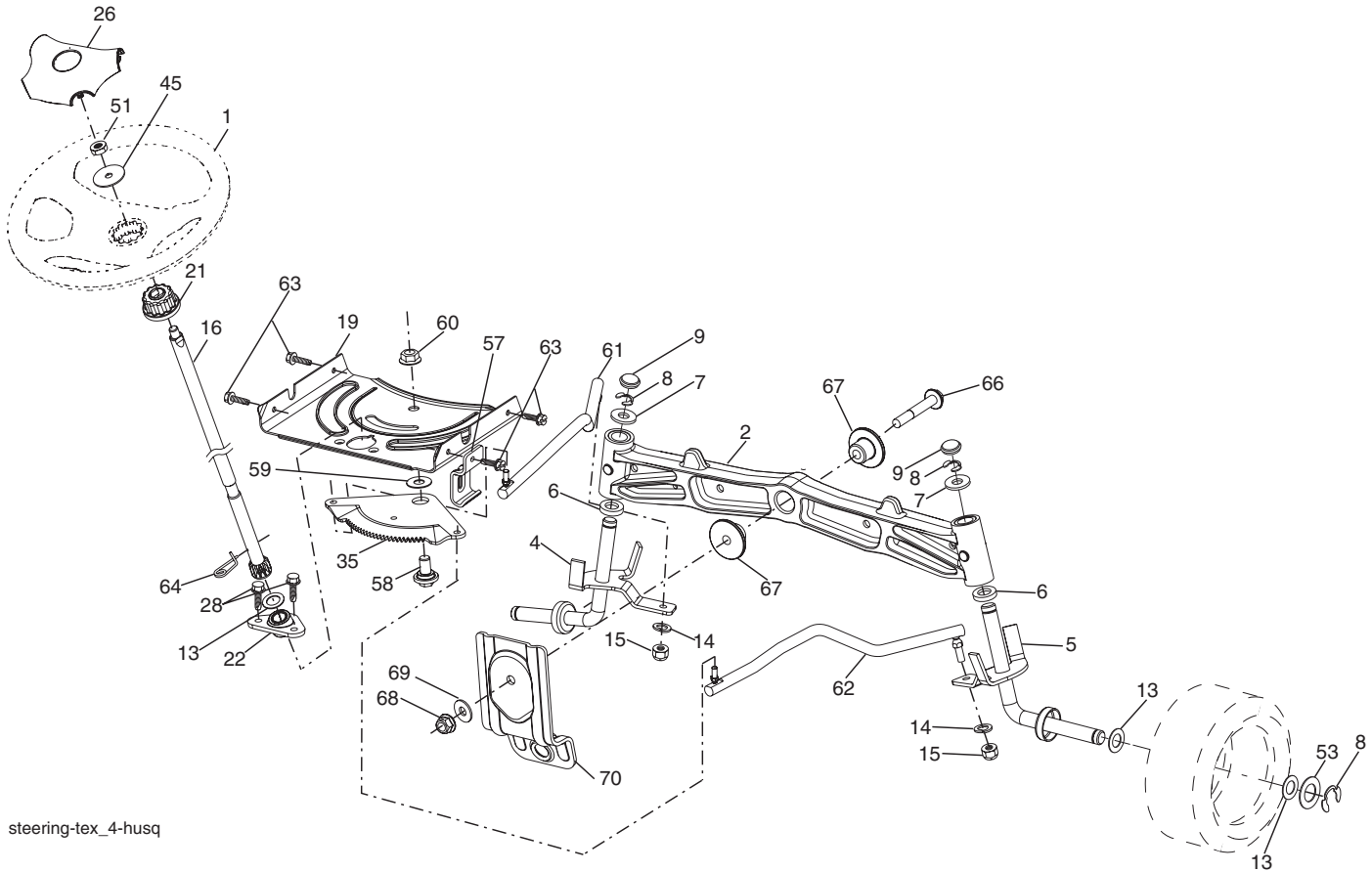

steering-tex_4-husq

KEY NO.	PART NO.	DESCRIPTION
1	532 19 39-43	Wheel, Steering
2	532 19 59-68	Axle Asm., Front
4	532 40 30-89	Spindle Asm., LH
5	532 40 30-90	Spindle Asm., RH
6	532 12 49-31	Bearing, Race Thrust Harden
7	532 12 17-48	Washer 25/32 x 1-5/8 x 16 Ga.
8	812 00 00-29	Ring, Klip #T5304-75
9	532 12 12-32	Cap, Spindle
13	532 12 17-49	Washer 25/32 x 1-1/4 x 16 Ga.
14	810 04 06-00	Washer, Lock Hvy Hlcl Spr 3/8
15	873 54 06-00	Nut, Crown Lock 3/8-24 unf
16	532 40 82-19	Shaft Steering
19	532 19 47-29	Plate Steering
21	532 18 67-37	Adapter, Wheel Steering
22	532 19 48-45	Bushing, Strg. Blk
26	532 19 36-52	Insert, Wheel Steering
28	817 00 06-12	Screw 3/8-16 x 3/4
35	532 19 47-32	Gear, Sector Plate
45	819 18 38-12	Washer 9/16 x 2-3/8 x 12 Ga.

KEY NO.	PART NO.	DESCRIPTION
51	873 94 08-00	Nut Hex Jam Toplock 1/2-20 unf
53	532 18 89-67	Washer Hardened .793 x 1.637 x .060
57	532 19 72-46	Bracket Upstop
58	532 19 47-47	Bolt Shoulder Sector Pivot CFM
59	532 19 47-48	Washer Thrust Sector Steering
60	873 97 10-00	Nut Flange Lock 5/8-11
61	532 19 47-40	Draglink, LH
62	532 19 47-41	Draglink, RH
63	817 00 05-12	Screw 5/16-18 x 3/4
64	532 19 98-49	Retainer Clip Spring Steering
66	871 02 07-48	Bolt Hex Fghd 7/16-14 x 3 Serr
67	532 19 47-37	Bushing PM Front Axle
68	873 90 07-00	Nut Lock Flange 7/16-14 Gr. 5
69	532 19 91-62	Washer 1.5 x .505 x .118
70	532 19 61-97	Bracket Deck Susp. Front

NOTE: All component dimensions given in U.S. inches
 1 inch = 25.4 mm

**TRACTOR - MODEL NO. GTH2648 (96043003001), PRODUCT NO. 960 43 00-30
SEAT ASSEMBLY**

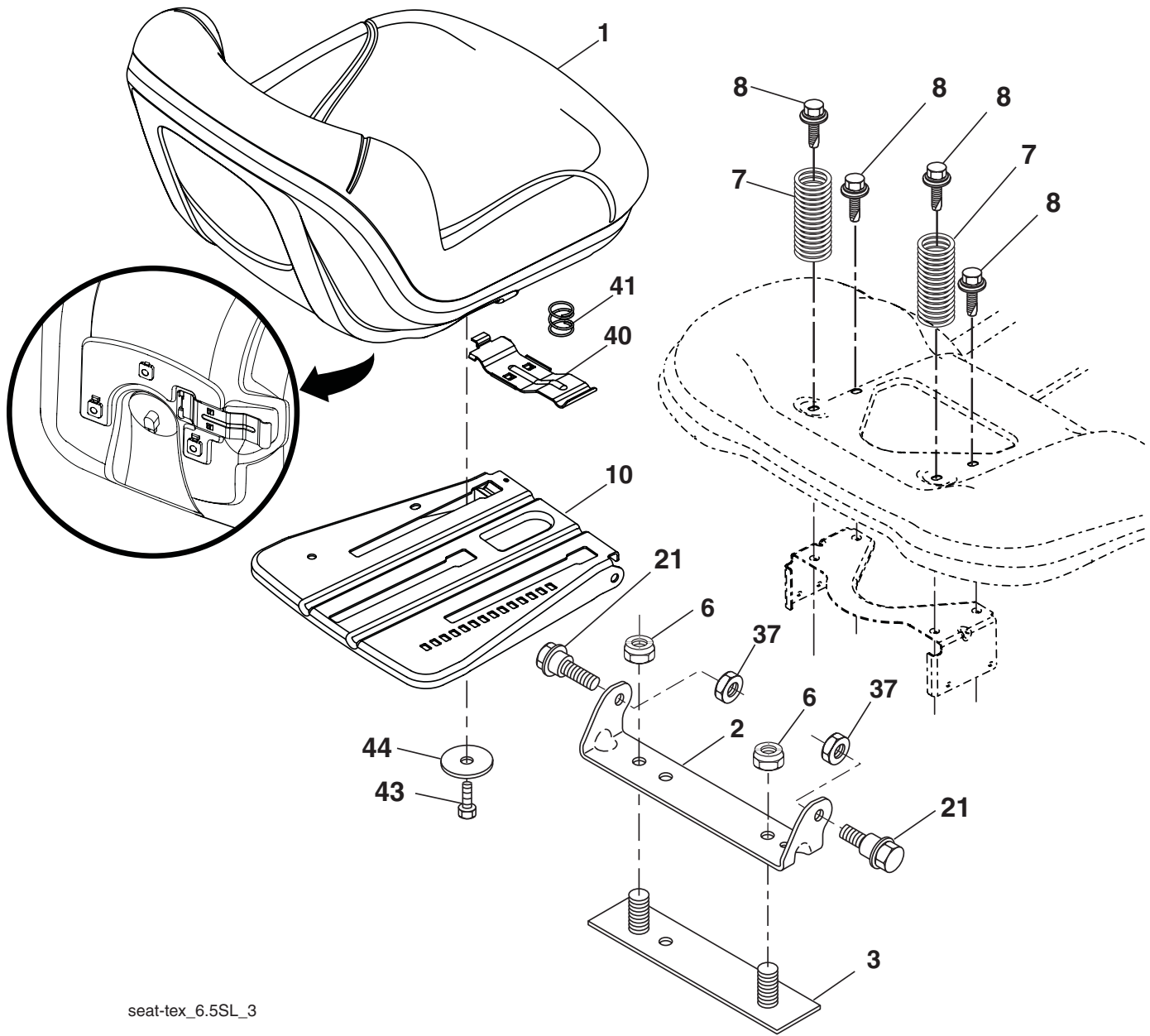

seat-tex_6.5SL_3

KEY NO.	PART NO.	DESCRIPTION
1	532 40 66-21	Seat
2	532 18 01-66	Bracket Pivot Fender
3	532 14 06-75	Strap, Asm Fender
6	873 80 06-00	Nut, Lock w/Ins. 3/8-16 unc
7	532 12 41-81	Spring, Seat Cprsn
8	532 17 18-77	Bolt 5/16-18 unc x 3/4 w/Sems
10	532 19 69-77	Pan, Seat
21	532 17 18-52	Bolt, Shoulder 5/16-18

KEY NO.	PART NO.	DESCRIPTION
37	873 80 05-00	Nut, Lock 5/16-18 unc
40	532 19 76-61	Handle Slide Seat
41	532 19 82-00	Spring Latch Seat
43	874 76 06-12	Bolt Fin Hex 3/8-16 unc x 3/4
44	819 13 38-12	Washer 13/32 x 2-3/8 x 12 Ga.

NOTE: All component dimensions given in U.S. inches
1 inch = 25.4 mm

TRACTOR - MODEL NO. GTH2648 (96043003001), PRODUCT NO. 960 43 00-30 MOWER DECK

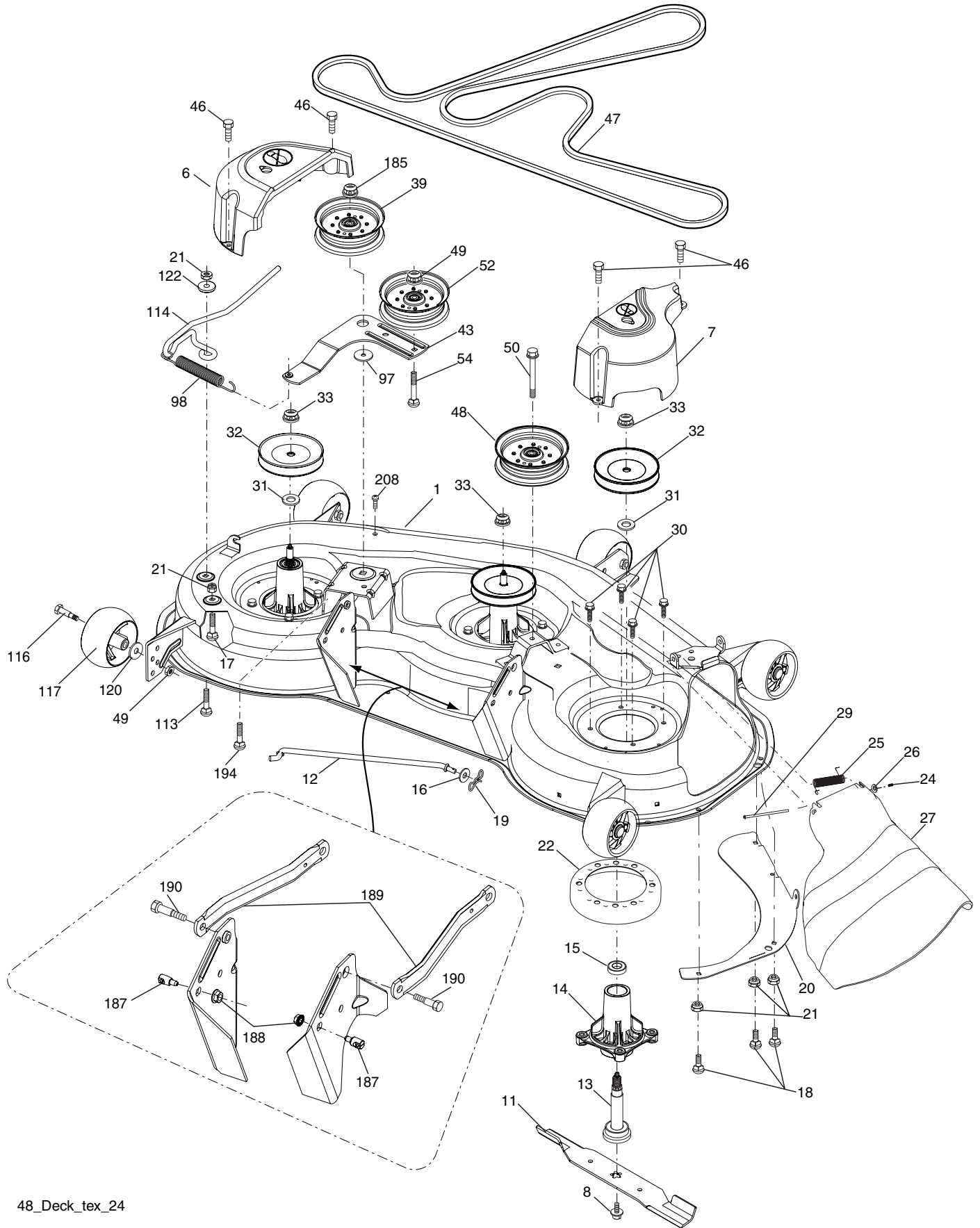

48_Deck_tex_24

**TRACTOR - MODEL NO. GTH2648 (96043003001), PRODUCT NO. 960 43 00-30
MOWER DECK**

KEY NO.	PART NO.	DESCRIPTION
1	532 40 35-82	Deck Weldment Mower
6	532 19 72-48	Cover Mandrel LH
7	532 19 91-02	Cover Mandrel RH
8	532 17 43-65	Bolt 7/16 Asm. Blade
11	532 18 00-54	Blade High Lift
12	532 40 03-37	Rod Anti-Sway
13	532 18 72-91	Shaft Asm. w/Lower Bearing
14	532 18 72-81	Housing, Mandrel
15	532 11 04-85	Bearing, Ball, Mandrel
16	819 13 13-12	Washer 13/32 x 13/16 x 12 Ga.
17	872 11 05-05	Bolt Carriage 5/16-18 x 5/8
18	872 14 05-05	Bolt RdHd 5/16-18 unc x 5/8
19	532 19 42-08	Pin Cotter 5/16 Bowtie Lock
20	532 17 43-78	Baffle Vortex Mower
21	873 68 05-00	Nut, Crownlock 5/16-18 unc
22	532 17 44-93	Stripper Mandrel Deck
24	532 10 53-04	Cap Sleeve
25	532 17 81-02	Spring, Torsion
26	532 11 04-52	Nut, Push
27	532 18 17-07	Deflector Shield
29	532 13 14-91	Rod, Hinge
30	532 17 39-84	Screw, Thdroll Washer Head
31	532 18 76-90	Washer, Spacer Mower Vented
32	532 15 35-32	Pulley, Mandrel
33	532 40 02-34	Nut, Flg. Top Lock
39	532 19 73-80	Pulley, Idler, 4.50
43	532 19 60-65	Arm, Idler
46	532 13 77-29	Screw, Thdroll. 1/4-20 x 5/8
47	532 19 72-42	Belt Deck Drive

KEY NO.	PART NO.	DESCRIPTION
48	532 19 31-97	Pulley Idler Clutching
49	873 90 06-00	Nut, Lock Flg. 3/8-16 unc
50	872 11 06-12	Bolt Carriage 3/8-16 x 1-1/2 Gr. 5
52	532 19 73-79	Pulley Idler
54	817 49 06-36	Screw 3/8-16 x 2-1/4
97	532 17 85-15	Washer Hardened
98	532 19 61-05	Spring Drive
113	872 11 05-08	Bolt Rdhd Sqnk 5/16-18 x 3/4
114	532 19 74-51	Rod Tension Relief
116	532 19 34-06	Bolt, Shoulder
117	532 17 48-73	Gauge Wheel
120	819 13 20-12	Washer 13/32 x 1-1/4 x 12 Ga.
122	532 18 75-57	Bushing Tension Relief
185	873 90 07-00	Nut Lock Flange 7/16-14 Gr. 5
187	532 19 51-61	Stud Fastener w/"D" Anti-Rotation
188	873 90 05-00	Nut Lock Hex Flange
189	532 19 51-85	Arm Susp. Mower Rear
190	532 19 65-39	Bolt Shoulder
194	872 14 07-16	Bolt Carr Sqnk 7/16-24 x 2
208	817 67 06-08	Screw THDROL 3/8-16 x 1/2
--	532 18 72-92	Mandrel Assembly (Includes housing, shaft assembly, and bearing only - pulley/nut/washer and blade bolt/washers not included)
--	532 40 12-38	Replacement Mower, Complete

NOTE: All component dimensions given in U.S. inches
1 inch = 25.4 mm

**TRACTOR - MODEL NO. GTH2648 (96043003001), PRODUCT NO. 960 43 00-30
MOWER LIFT**

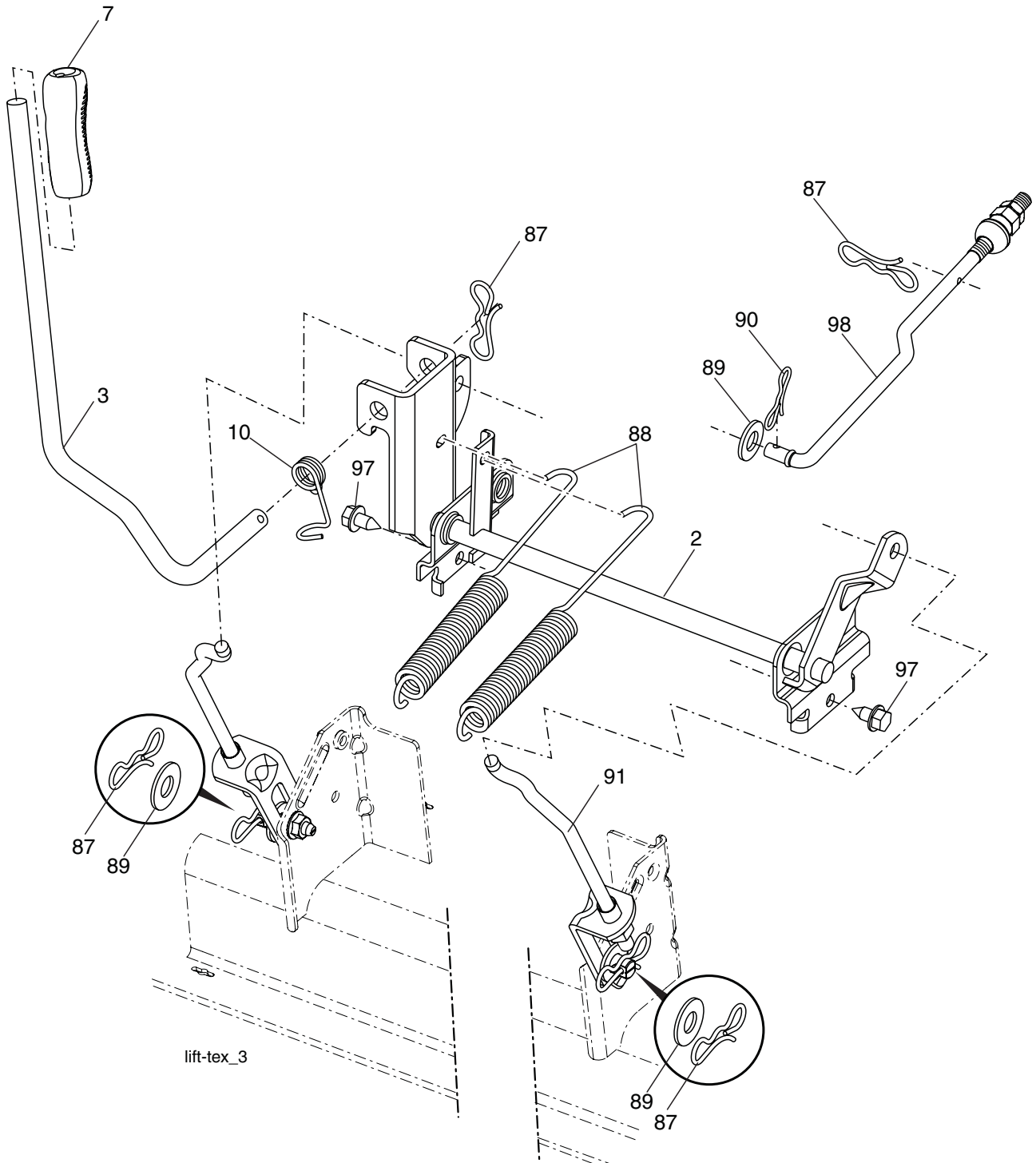

KEY NO.	PART NO.	DESCRIPTION
2	532 19 52-23	Shaft Asm., Lift
3	532 19 52-30	Lever Asm., Lift RH
7	532 19 64-92	Grip, Lever
10	532 19 63-14	Spring Torsion
87	532 19 42-09	Pin Cotter 7/16 Bow Tie Lock
88	532 19 53-04	Spring Lift Assist
89	819 19 19-12	Washer Clear Zinc

KEY NO.	PART NO.	DESCRIPTION
90	532 19 42-08	Pin Cotter 5/16 Bow Tie Lock
91	532 19 79-84	Link Lift Susp Mower Rear
97	817 00 06-12	Screw 3/8-16 x 3/4
98	532 19 52-64	Link Lift Susp. Front Mower

NOTE: All component dimensions given in U.S. inches
1 inch = 25.4 mm