

YTH2454

Illustrated Parts List / 96043005401 / 2008-12

**TRACTOR - MODEL NO. YTH2454 (96043005401), PRODUCT NO. 960 43 00-54
DECALS**

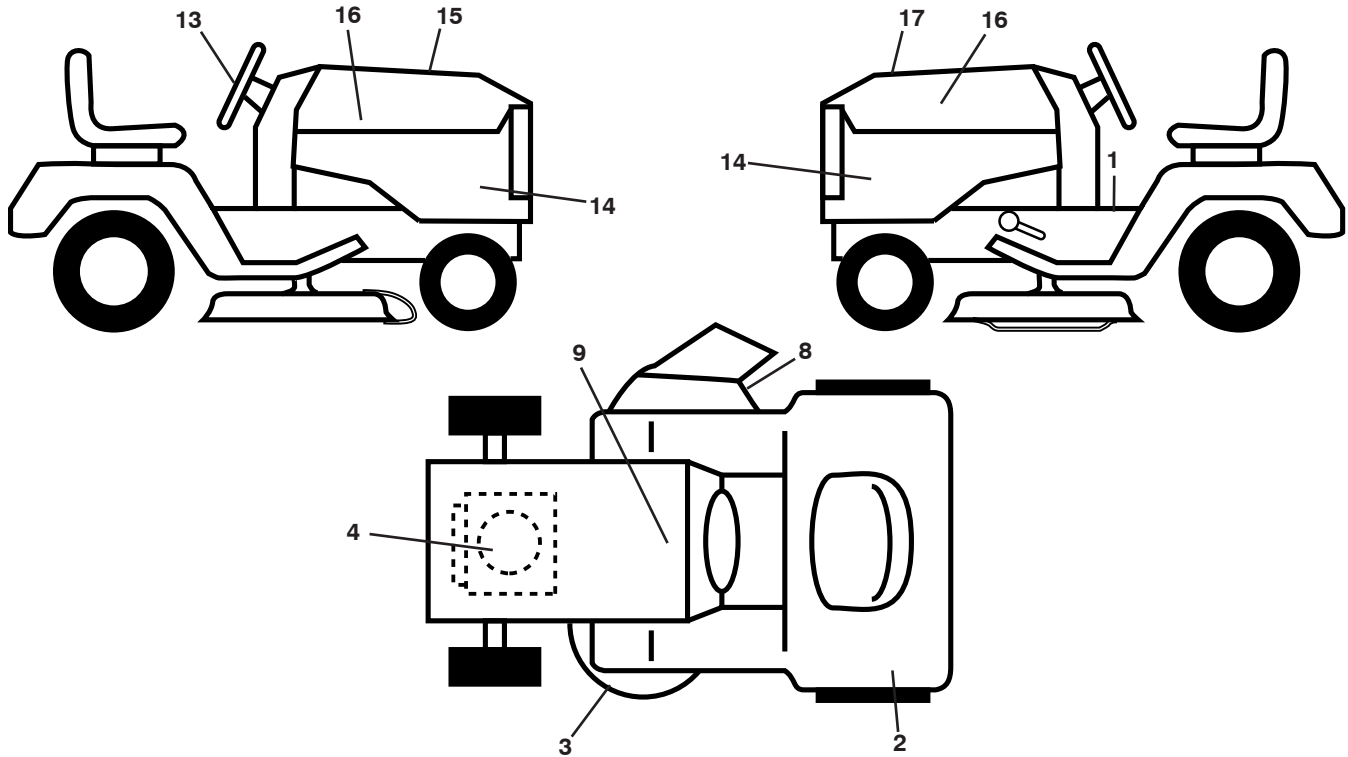

KEY NO.	PART NO.	DESCRIPTION
1	532 41 16-58	Decal, Warning
2	532 42 38-30	Decal, Ethanol Warning
3	532 17 05-63	Decal, Warning
4	532 42 20-57	Decal, Engine HP
8	532 19 87-85	Decal, Mower Sch.
9	532 14 50-05	Decal, Battery Dnge/Poi
13	532 40 44-84	Decal, Steering Whl
14	532 41 05-01	Decal, Panel Side

KEY NO.	PART NO.	DESCRIPTION
15	532 42 38-29	Decal, Cust. Resp.
16	532 42 20-12	Decal, Hood Logo
17	532 42 57-35	Decal, Replacement
--	532 16 69-60	Decal, Bypass
--	532 40 17-71	Pad, Footrest, LH
--	532 40 37-73	Pad, Footrest, RH

WHEELS AND TIRES

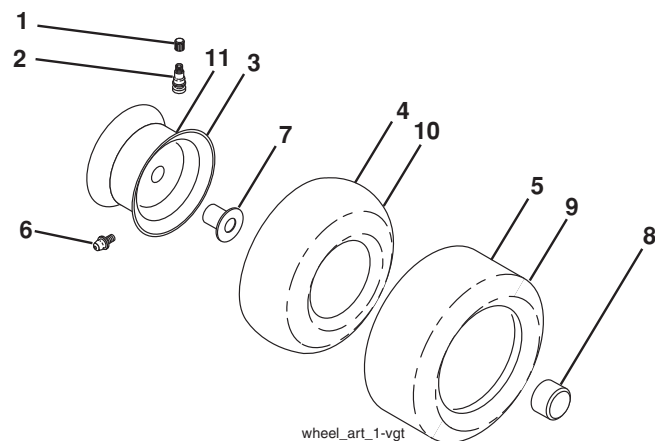

KEY NO.	PART NO.	DESCRIPTION
1	532 05 91-92	Cap, Valve, Tire
2	532 06 51-39	Stem, Valve
3	532 14 45-09	Rim Assembly, Front
4	532 00 81-34	Tube, Front (Service Item Only)
5	532 10 62-30	Tire, Front
6	532 12 49-57	Fitting, Grease (Front Wheel Only)
7	532 12 49-59	Bearing, Flange (Front Wheel Only)
8	532 17 50-39	Cap, Axle (Front Wheel Only)
9	532 12 20-82	Tire, Rear
10	532 12 49-26	Tube, Rear (Service Item Only)
11	532 13 83-37	Rim Assembly, Rear
--	532 14 43-34	Sealant, Tire (10 oz. Tube)

NOTE: All component dimensions given in U.S. inches
1 inch = 25.4 mm

TRACTOR - MODEL NO. YTH2454 (96043005401), PRODUCT NO. 960 43 00-54 SCHEMATIC

SCH12

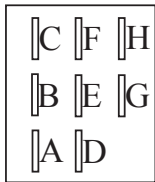
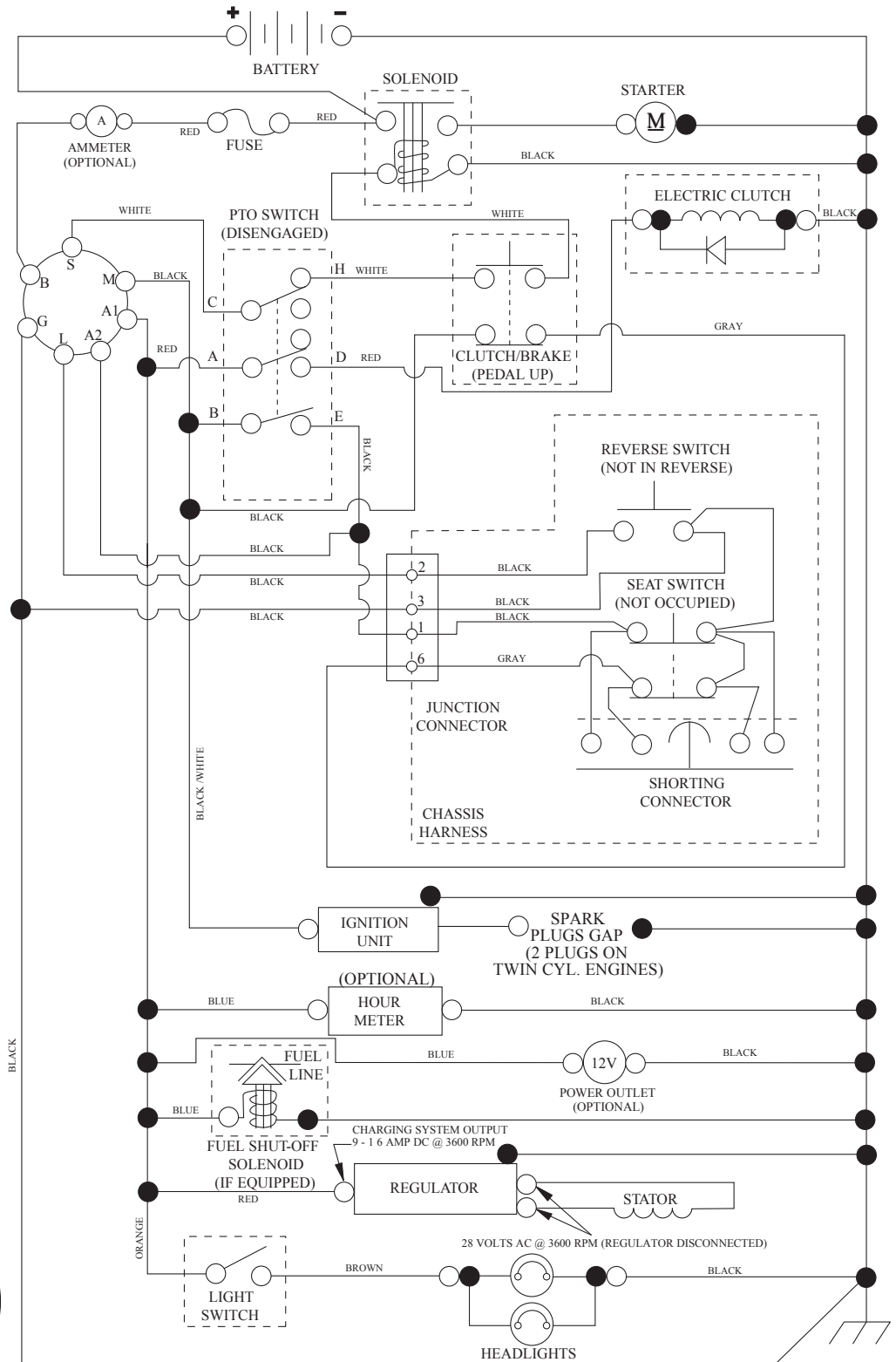

PTO SWITCH
(MATING SIDE)

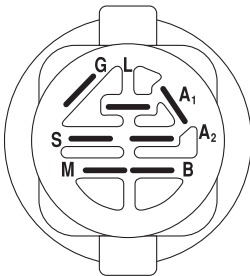

IGNITION SWITCH

POSITION	CIRCUIT	"MAKE"
OFF	M+G+A1	
RUN/OVERRIDE	B+A1	
RUN	B+A1	L+A2
START	B + S + A1	

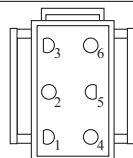

CHASSIS HARNESS
CONNECTOR
(MATING SIDE)

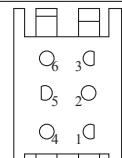

DASH HARNESS
CONNECTOR

WIRING INSULATED CLIPS
NOTE: IF WIRING INSULATED
CLIPS WERE REMOVED FOR
SERVICING OF UNIT, THEY
SHOULD BE RE-INSTALLED TO
PROPERLY SECURE YOUR
WIRING.

●
NON-REMOVABLE
CONNECTIONS

○
REMOVABLE
CONNECTIONS

**TRACTOR - MODEL NO. YTH2454 (96043005401), PRODUCT NO. 960 43 00-54
ELECTRICAL**

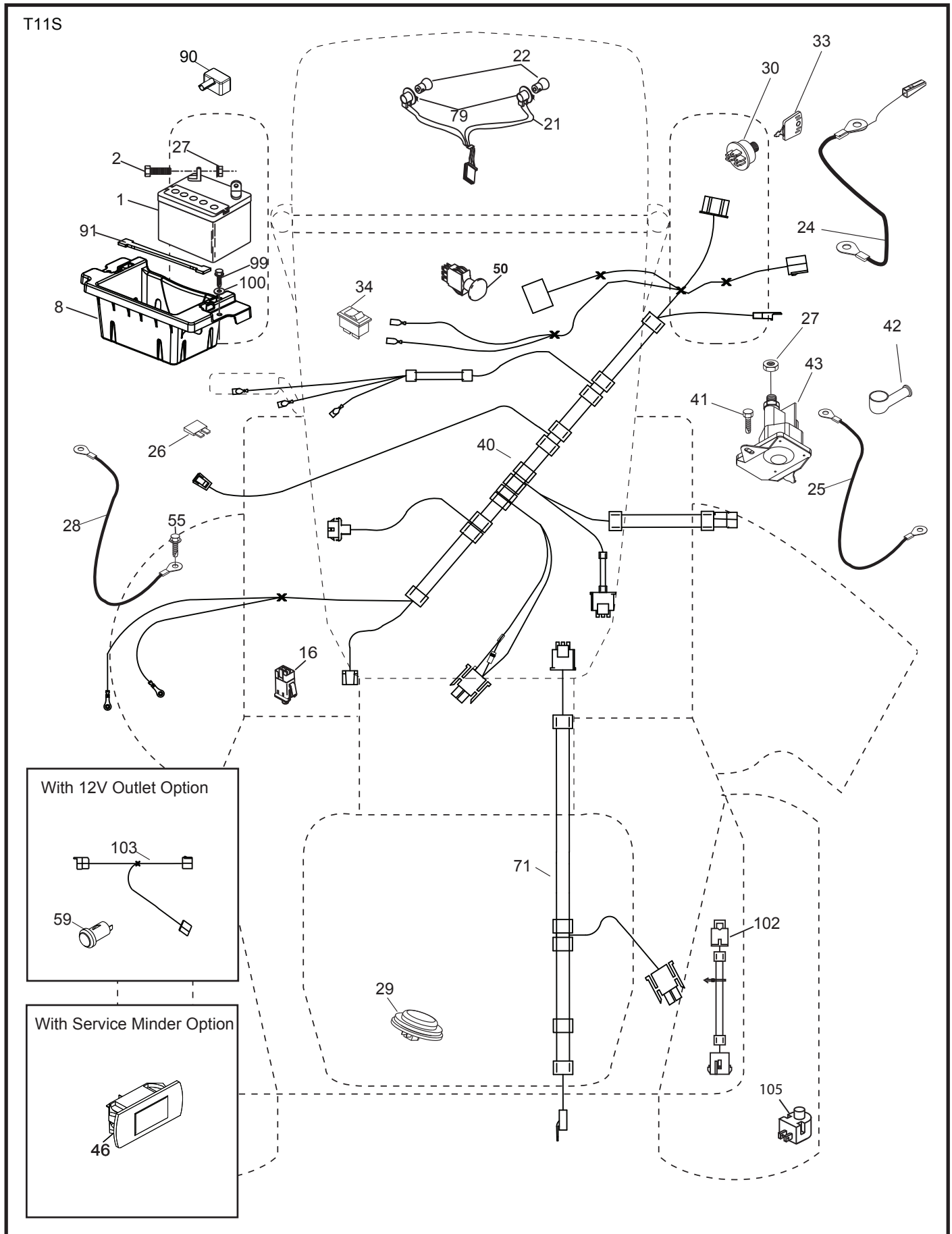

**TRACTOR - MODEL NO. YTH2454 (96043005401), PRODUCT NO. 960 43 00-54
ELECTRICAL**

KEY NO.	PART NO.	DESCRIPTION
1	532 16 34-65	Battery
2	874 76 04-12	Bolt Hex Hd 1/4-20 unc x 3/4
8	532 18 64-91	Battery Box
16	532 17 61-38	Switch Interlock
21	532 18 37-59	Harness Socket Light
22	532 00 41-52	Bulb, Light #1156
24	532 40 02-53	Cable Battery
25	532 41 28-95	Cable Starter
26	532 17 51-58	Fuse
27	873 51 04-00	Nut Keps Hex 1/4-20 unc
28	532 14 54-91	Cable Ground 21" Blk 6 Ga.
29	532 40 15-45	Switch Seat
30	532 19 33-50	Switch Ign
33	532 41 19-35	Key/Chain
34	532 11 07-12	Switch Light/Reset
40	532 40 11-04	Harness Ign. Dash
41	817 72 04-08	Screw Thd Cut 1/4-20 x 1/2
42	532 13 15-63	Cover Terminal Red
43	532 19 25-07	Solenoid
46	532 40 17-63	Gauge Hourmeter
50	532 17 46-51	Switch PTO
55	817 06 05-12	Screw Thdrol 5/16-18 x 3/4
59	532 40 03-03	Outlet 12-Volt
71	532 19 42-76	Harness Chassis
79	532 17 52-42	Socket Asm Bulb
90	532 40 07-24	Cover Terminal Battery
91	532 19 02-70	Strap Battery
99	817 67 04-12	Screw Hexwsh Thdrol 1/4-20 x 3/4
100	819 09 14-16	Washer 9/32 x 7/8 x 16 Ga.
102	532 40 44-54	Harness Pigtail
103	532 40 79-62	Harness Pigtail
105	532 40 75-68	Switch Reverse

NOTE: All component dimensions given in U.S. inches
1 inch = 25.4 mm

**TRACTOR - MODEL NO. YTH2454 (96043005401), PRODUCT NO. 960 43 00-54
CHASSIS**

KEY NO.	PART NO.	DESCRIPTION	KEY NO.	PART NO.	DESCRIPTION
3	532 40 50-12	Logo	198	532 41 18-81	Indicator Deck Lift
5	532 40 87-01	Dash	199	532 19 63-77	Plate Deck Lift
14	532 41 10-46	Hood	202	532 40 30-48	Vent Side Hood RH
15	532 19 89-07	Lens LH	203	532 40 30-76	Vent Side Hood LH
18	532 40-86-07	Grille/Lens Asm.	204	532 41 66-13	Vent Top Hood
25	532 19 89-06	Lens RH	205	532 40 17-09	Skirt Hood Side RH
34	532 19 61-25	Plate Engine	206	532 40 17-11	Skirt Hood Side LH
36	817 06 05-12	Screw 5/16-18 x 3/4	207	532 19 71-98	Bezel RH
37	532 42 58-79	Fender	208	532 19 71-99	Bezel LH
52	873 68 05-00	Nut Lock 5/16-18	209	532 19 91-30	Insert Hex Top RH
58	532 41 22-81	Drawbar Upper	210	532 19 91-31	Insert Hex Top LH
68	817 49 05-08	Screw Thdrol. 5/16-18 x 1/2	211	532 19 91-32	Insert Hex Bottom RH
130	532 41 63-58	Screw #10 x 0.750	212	532 19 91-33	Insert Hex Bottom LH
137	532 40 75-90	Bumper Dash	213	874 76 05-12	Bolt 5/16-18 x 3/4
150	532 19 85-12	Air Duct	214	532 19 91-45	Clip Retainer
152	532 19 95-35	Shield Browning	217	532 40 91-67	Rod Pivot
161	532 42 58-83	Console Fuel Window	218	532 19 63-95	X-Piece Hood Stop
162	532 14 24-32	Screw	222	532 13 77-29	Screw 1/4-20 x 5/8
165	532 19 68-26	Support Tank Rear	228	532 19 51-61	Stud Fastner
175	532 19 63-04	Crossmember	233	532 19 65-39	Bolt Shoulder
176	532 40 07-76	Screw 10-24 x 5/8	234	532 40 47-42	Bumper Hood
177	532 19 52-27	Bushing Steering	235	532 40 61-29	Spacer Fender
178	532 19 97-82	Cargo Net Asm.	236	873 93 05-00	Nut Lock 5/16-18 unc
180	532 41 50-63	Chassis	238	532 40 86-06	Trim
181	532 40 30-25	Bushing Mtg. Fender Crgo	239	532 11 04-52	Nut, Push
182	532 40 68-59	Dash Lower			
183	874 78 05-20	Bolt Fin. Hex 5/16-18 unc x 1-1/4			
189	817 00 05-12	Screw 5/16-18 x 3/4			
194	873 90 05-00	Nut Lock Hex Flange 5/16-18			
196	532 42 58-84	Console Asm. Deck Lift			

NOTE: All component dimensions given in U.S. inches
1 inch = 25.4 mm

TRACTOR - MODEL NO. YTH2454 (96043005401), PRODUCT NO. 960 43 00-54 DRIVE

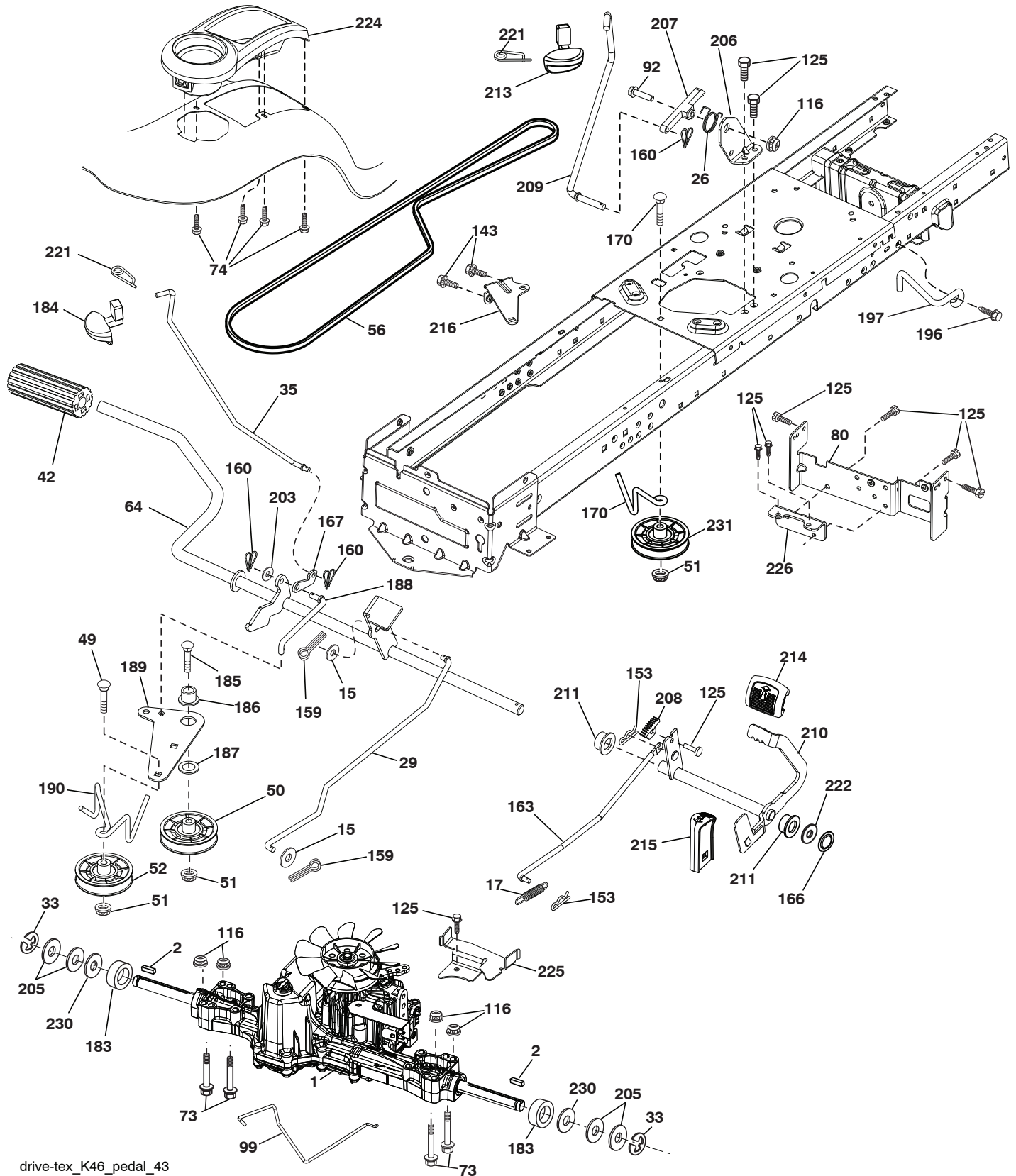

drive-tex_K46_pedal_43

**TRACTOR - MODEL NO. YTH2454 (96043005401), PRODUCT NO. 960 43 00-54
DRIVE**

KEY NO.	PART NO.	DESCRIPTION	KEY NO.	PART NO.	DESCRIPTION
1	532 40 53-84	Transaxle, TUFFTORQ K46 BT (Internal parts not available)	183	532 13 70-57	Spacer Split
2	532 12 35-83	Key 1/4 x 2.5	184	532 40 31-18	Handle Parking Brake
15	819 13 13-16	Washer 13/32 x 13/16 x 16 Ga.	185	872 11 06-22	Bolt Rdhd. Sqnk. 3/8-16uncx2-3/4
17	532 41 36-78	Spring, Brake	186	532 19 43-21	Spacer Retainer
26	532 19 96-79	Spring Return Cruise	187	819 13 32-10	Washer
29	532 40 38-06	Rod, Brake	188	532 19 43-23	Link Clutch Ground Drive
33	812 00 00-01	Ring E	189	532 19 43-17	Bellcrank Ground Drive
35	532 19 95-91	Rod, Brake, Park	190	532 19 43-18	Keeper Bellcrank Ground Drive
42	532 12 48-72	Cover, Foot Pedal	196	817 00 06-16	Screw 3/8-16 x 1
49	872 11 06-14	Bolt	197	532 19 97-69	Link Clutch Anti-Rotation
50	532 19 43-27	Pulley Idler Flat	205	532 12 17-48	Washer
51	873 90 06-00	Lock Nut 3/8-16	206	532 19 78-67	Bracket Mount Latch Cruise
52	532 19 43-26	Idler V-Groove 910" Offset	207	532 19 78-68	Latch Control Cruise
56	532 13 09-69	V-Belt, Drive	208	532 19 78-69	Gear Sector Control Cruise
64	532 19 78-65	Shaft Asm. Pedal Brake Control	209	532 19 95-92	Rod Control Cruise
70	532 40 05-30	Console Asm.	210	532 19 78-60	Rocker Asm. Pedal Control
73	874 49 05-44	Bolt Hex Flghd. 5/16-18 x Gr. 5	211	532 12 01-83	Bearing Nylon
74	532 14 24-32	Screw 1/4 x 1/2	213	532 40 31-19	Knob Control Cruise
80	532 41 00-24	Bracket Strap Torque	214	532 42 12-63	Pedal Forward Pad
92	874 76 05-20	Bolt Fin. Hex 5/16-18 unc x 1.25	215	532 40 17-23	Pedal Reverse
99	532 41 57-42	Rod Bypass	216	532 19 61-31	Bracket Pulley Idler
116	873 90 05-00	Nut Lock Hex Flange 5/16-18	220	532 19 89-08	Reflector RH
125	817 00 05-12	Screw 5/16-18 x 3/4	221	532 40 31-87	Retainer Spring Clip Handle
143	817 49 05-08	Screw 5/16-18 x 1/2	222	879 21 20-10	Washer 21/32 x 1-1/4 x 10 Ga.
153	532 12 47-88	Retainer Spring	224	532 42 58-90	Console Toolbox
159	876 02 04-12	Pin Cotter 1/8 x 3/4	225	532 40 33-19	Keeper Belt Trans.
160	532 16 94-84	Retainer Clip	226	532 40 15-64	Bracket Mount Torque
161	532 10 57-09	Spring, Return, Clutch	230	532 18 89-67	Washer Hardened
163	532 40 10-34	Rod Pedal Control	231	532 40 72-87	Idler V-Groove
166	532 19 72-90	Nut Push .625			
167	532 40 52-57	Latch Brake Parking			
170	532 41 34-30	Keeper Belt Centerspan			

NOTE: All component dimensions given in U.S. inches
1 inch = 25.4 mm

**TRACTOR - MODEL NO. YTH2454 (96043005401), PRODUCT NO. 960 43 00-54
ENGINE**

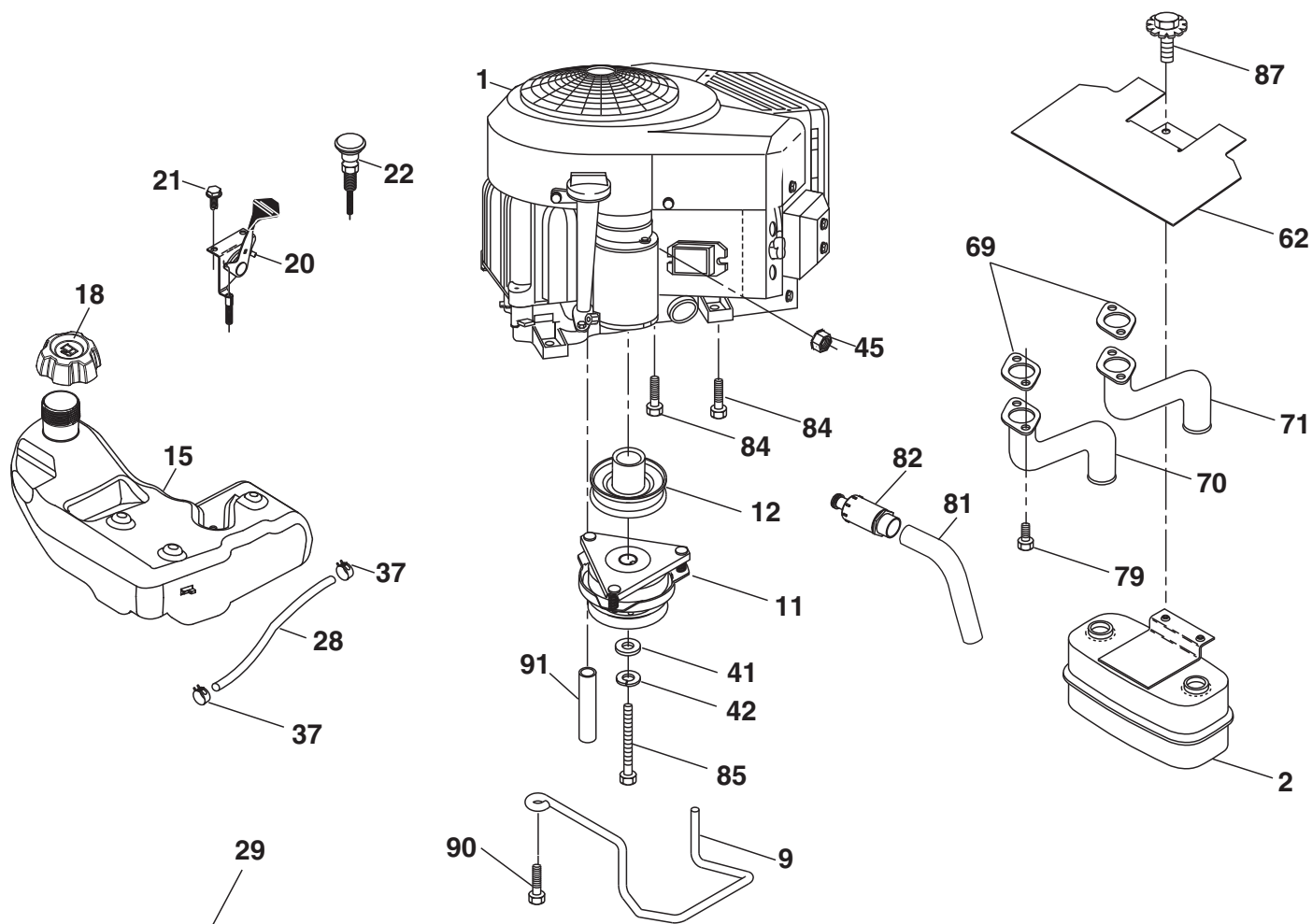

SPARK ARRESTER KIT

engine-tex_BS_21

TRACTOR - MODEL NO. YTH2454 (96043005401), PRODUCT NO. 960 43 00-54 ENGINE

KEY NO.	PART NO.	DESCRIPTION
1	-----	Engine Briggs Model No. 446677
2	532 14 97-23	Muffler
9	532 19 43-20	Keeper Belt Engine
11	532 17 93-35	Clutch Electric
12	532 19 43-43	Pulley Engine
15	532 19 34-99	Tank Fuel 4.0
18	532 19 42-67	Cap Asm
20	532 17 83-85	Control Throttle
21	532 41 63-58	Screw #10 x 0.750
22	532 19 15-96	Control Choke
28	532 40 11-35	Fuel Line
29	532 13 71-80	Spark Arrester Kit
37	532 12 34-87	Clamp Hose
41	532 12 61-97	Washer 1-1/2 OD x 15/32 ID x .250
42	810 04 07-00	Washer Lock 7/16
45	873 51 04-00	Nut Keps Hex 1/4-20 unc
62	532 14 66-29	Shield Heat Muffler
69	532 16 53-91	Gasket
70	532 15 99-55	Tube Exhaust LH
71	532 16 05-89	Tube Exhaust RH
79	532 18 39-06	Screw Socket Head 5/16-18 x 1
81	532 14 84-56	Tube Drain Oil Easy
82	532 18 16-54	Plug Drain Oil Easy
84	817 06 06-20	Screw 3/8-16 x 1-1/4
85	532 17 99-53	Bolt Hex 7/16-20 x 3.75 Gr. 5
87	532 19 82-39	Bolt 5/16-18 unc x 1 w/Sems
90	817 00 06-16	Screw 3/8-16 x 1
91	532 18 74-95	Bushing

NOTE: All component dimensions given in U.S. inches
1 inch = 25.4 mm

For engine service and replacement parts, call the toll free
number for your engine manufacturer listed below:

Briggs & Stratton 1-800-233-3723

Engine Power Rating Information

The gross power rating for individual gas engine models is labeled in accordance with SAE (Society of Automotive Engineers) code J11940 (Small Engine Power & Torque Rating Procedure), and rating performance has been obtained and corrected in accordance with SAE J1995 (Revision 2002-5). Actual gross engine power will be lower and is affected by, among other things, ambient operating conditions and engine-to-engine variability. Given both the wide array of products on which engines are placed and the variety of environmental issues applicable to operating the equipment, the gas engine will not develop the rated gross power when used in a given piece of power equipment (actual "on-site" or net horsepower). This difference is due to a variety of factors including, but not limited to, accessories (air cleaner, exhaust, charging, cooling, carburetor, fuel pump, etc.), application limitations, ambient operating conditions (temperature, humidity, altitude), and engine-to-engine variability. Due to manufacturing and capacity limitations, Briggs & Stratton may substitute an engine of higher rated power for this Series engine.

**TRACTOR - MODEL NO. YTH2454 (96043005401), PRODUCT NO. 960 43 00-54
STEERING ASSEMBLY**

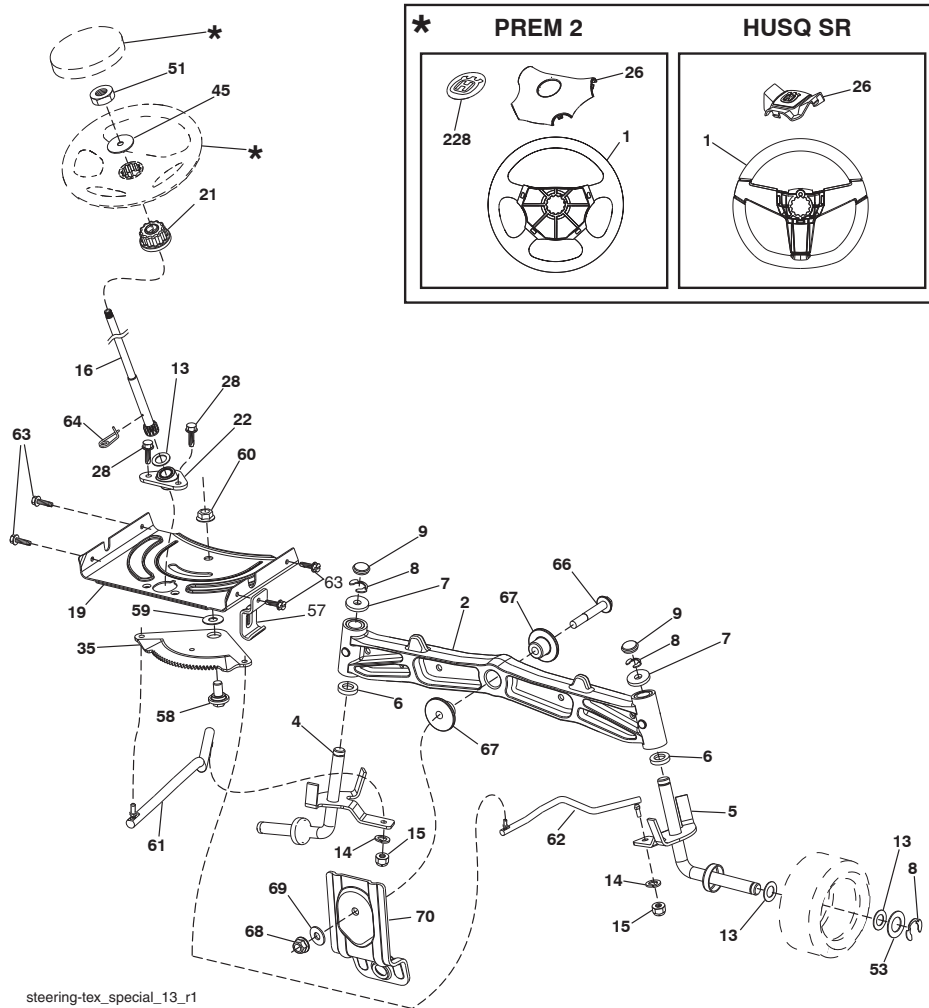

steering-tex_special_13_r1

KEY NO.	PART NO.	DESCRIPTION	KEY NO.	PART NO.	DESCRIPTION
1	532 42 34-69	Wheel, Steering (HUSQ SR)	51	873 94 08-00	Nut Hex Jam Toplock 1/2-20 unfl
--	532 19 36-51	Wheel, Steering (PREM 2)	53	532 18 89-67	Washer Hardened .793x1.637x.060
2	532 19 59-68	Axle Asm., Front	57	532 19 72-46	Bracket Upstop
4	532 40 30-89	Spindle Asm., LH	58	532 19 47-47	Bolt Shoulder Sector Pivot CFM
5	532 40 30-90	Spindle Asm., RH	59	532 19 47-48	Washer Thrust Sector Steering
6	532 12 49-31	Bearing, Race Thrust Harden	60	873 97 10-00	Nut Flange Lock 5/8-11
7	532 12 17-48	Washer 25/32 x 1-5/8 x 16 Ga.	61	532 19 47-40	Draglink, LH
8	812 00 00-29	Ring, Clip #T5304-75	62	532 19 47-41	Draglink, RH
9	532 12 12-32	Cap, Spindle	63	817 00 05-12	Screw 5/16-18 x 3/4
13	532 12 17-49	Washer 25/32 x 1-1/4 x 16 Ga.	64	532 19 98-49	Retainer Clip Spring Steering
14	810 04 06-00	Washer, Lock Hvy Hlcl Spr 3/8	66	871 02 07-48	Bolt Hex Fghd 7/16-14 x 3 Serr
15	873 54 06-00	Nut, Crown Lock 3/8-24 unfl	67	532 19 47-37	Bushing PM Front Axle
16	532 40 82-19	Shaft Steering	68	873 90 07-00	Nut Lock Flange 7/16-14 Gr. 5
19	532 19 47-29	Plate Steering	69	532 19 91-62	Washer 1.5 x .505 x .118
21	532 18 67-37	Adapter, Wheel Steering	70	532 19 61-97	Bracket Deck Susp. Front
22	532 19 48-45	Bushing, Strg. Blk	228	532 40 44-84	Decal, Wheel Steering
26	532 41 59-87	Insert, Wheel Steering (HUSQ SR)			
--	532 19 36-52	Insert, Wheel Steering (PREM 2)			
28	817 00 06-12	Screw 3/8-16 x 3/4			
35	532 19 47-32	Gear, Sector Plate			
45	819 18 38-12	Washer 9/16 x 2-3/8 x 12 Ga.			

NOTE: All component dimensions given in U.S. inches
1 inch = 25.4 mm

**TRACTOR - MODEL NO. YTH2454 (96043005401), PRODUCT NO. 960 43 00-54
SEAT ASSEMBLY**

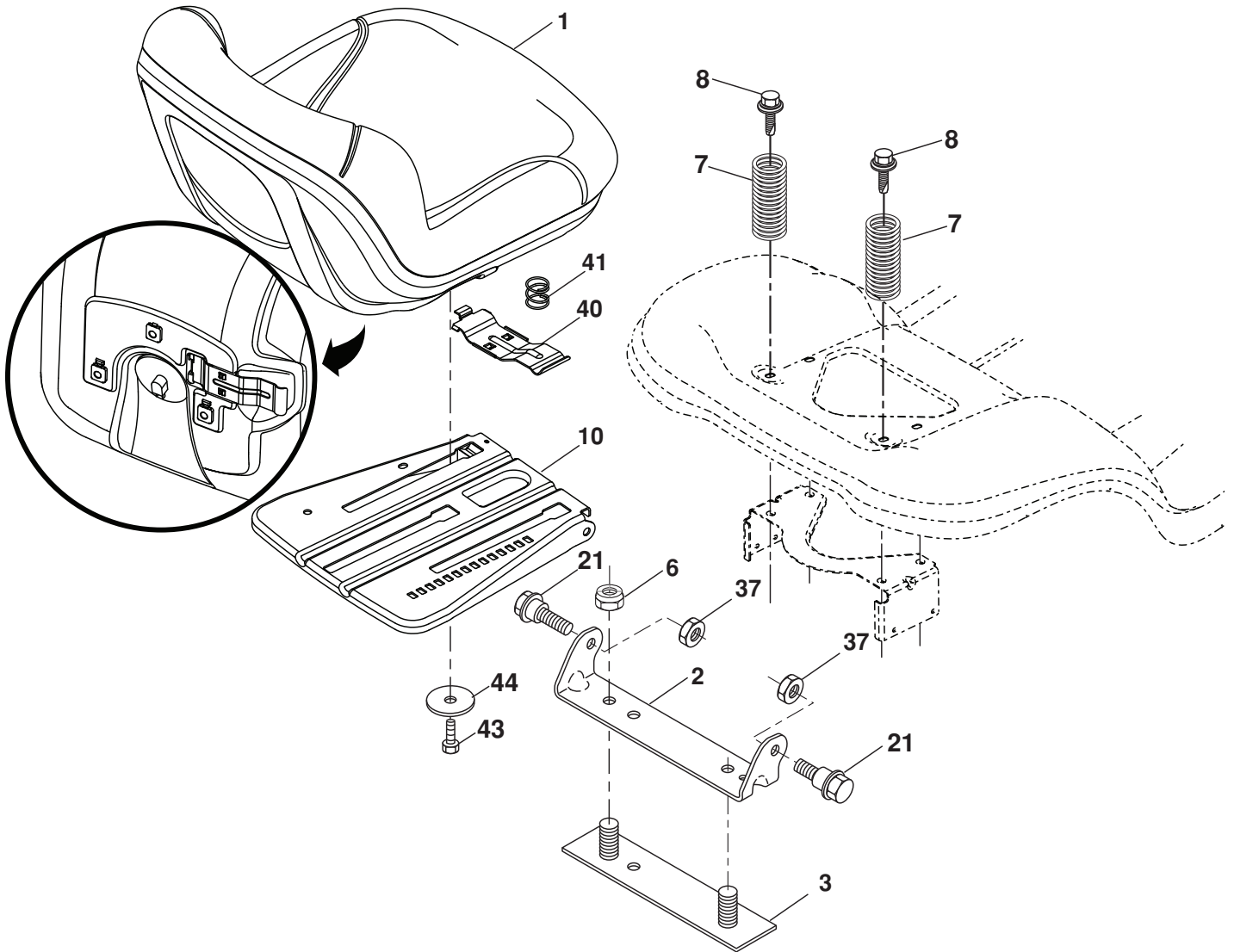

seat-tex_7-vgt

KEY NO.	PART NO.	DESCRIPTION
1	532 40 66-21	Seat
2	532 18 01-66	Bracket Pivot Fender
3	532 14 06-75	Strap, Asm Fender
6	873 80 06-00	Nut, Lock w/Ins. 3/8-16 unc
7	532 12 41-81	Spring, Seat Cprsn
8	532 17 18-77	Bolt 5/16-18 unc x 3/4 w/Sems
10	532 19 69-77	Pan, Seat
21	532 17 18-52	Bolt, Shoulder 5/16-18

KEY NO.	PART NO.	DESCRIPTION
37	873 80 05-00	Nut, Lock 5/16-18 unc
40	532 19 76-61	Handle Slide Seat
41	532 19 82-00	Spring Latch Seat
43	874 76 06-12	Bolt 3/8-16 x 3/4
44	819 13 38-12	Washer 13/32 x 2-3/8 x 12 Ga.

NOTE: All component dimensions given in U.S. inches
1 inch = 25.4 mm

**TRACTOR - MODEL NO. YTH2454 (96043005401), PRODUCT NO. 960 43 00-54
MOWER DECK**

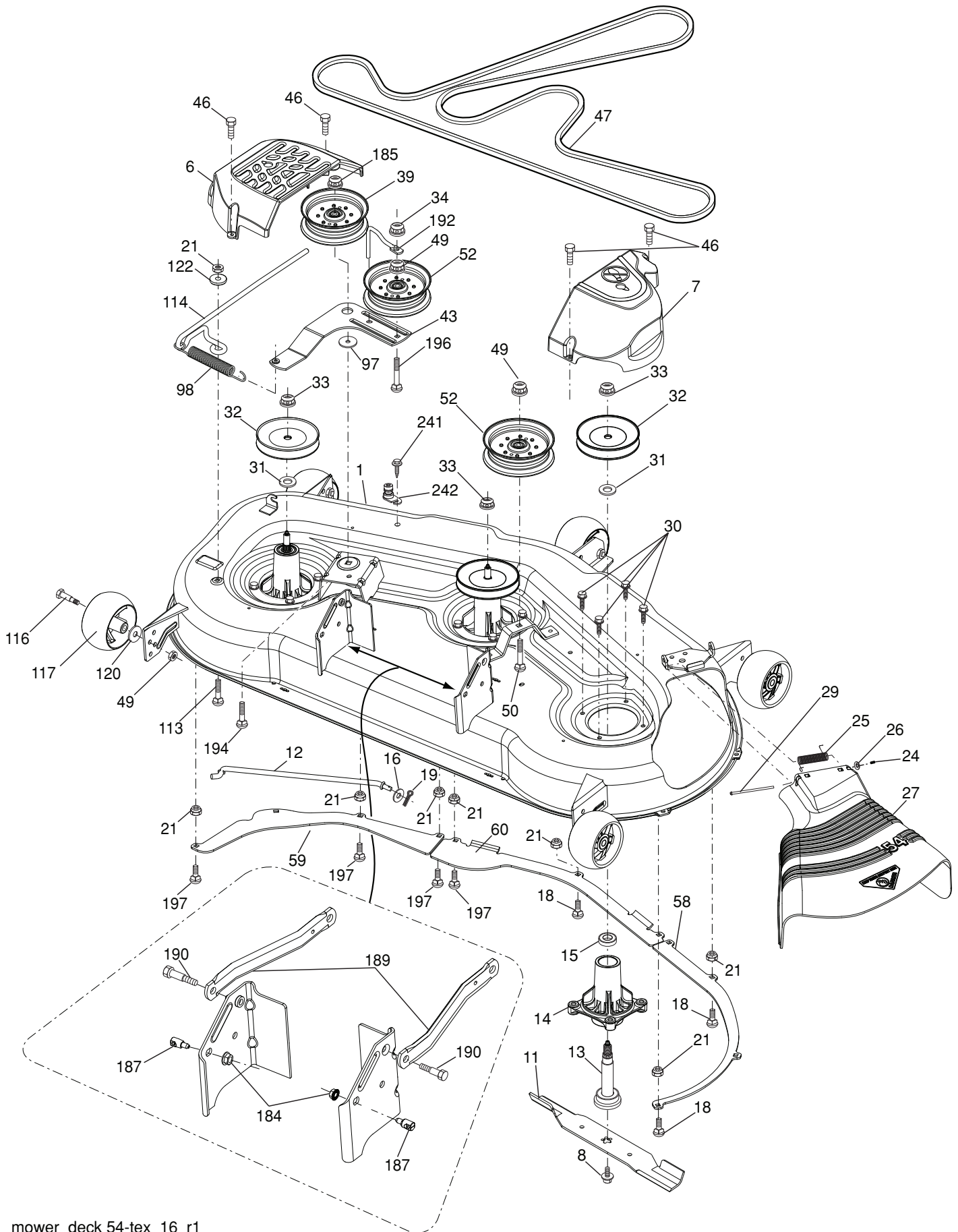

TRACTOR - MODEL NO. YTH2454 (96043005401), PRODUCT NO. 960 43 00-54 MOWER DECK

KEY NO.	PART NO.	DESCRIPTION	KEY NO.	PART NO.	DESCRIPTION
1	532 40 31-25	Deck Weldment Mower	59	532 18 73-44	Baffle Left
6	532 19 60-66	Cover Mandrel LH	60	532 18 76-07	Baffle Center
7	532 19 71-81	Cover Mandrel RH	97	532 17 85-15	Washer Hardened
8	532 19 30-03	Bolt 7/16 Asm. Blade	98	532 19 61-05	Spring Drive
11	532 18 72-56	Blade Bagging	113	872 11 05-08	Bolt Rdhd Sqnk 5/16-18 x 3/4
--	532 18 72-55	Blade Mulching	114	532 18 75-56	Rod Tension Relief
12	532 40 48-51	Bar Anti-Sway	116	532 19 34-06	Bolt, Shoulder
13	532 18 72-91	Shaft Asm. w/Lower Bearing	117	532 17 48-73	Gauge Wheel
14	532 18 72-81	Housing, Mandrel	120	819 13 20-12	Washer 13/32 x 1-1/4 x 12 Ga.
15	532 11 04-85	Bearing, Ball, Mandrel	122	532 18 75-57	Bushing Tension Relief
16	819 13 13-12	Washer 3/8	184	873 90 05-00	Nut Lock Hex Flange
18	872 14 05-05	Bolt RdHd 5/16-18 unc x 5/8	185	873 90 07-00	Nut Lock Flange 7/16-14 Gr. 5
19	532 19 42-08	Pin Cotter 5/16 Bowtie	187	532 19 51-61	Stud Fastener w/"D" Anti-Rotation
21	873 68 05-00	Nut, Crownlock 5/16-18 unc	189	532 19 51-85	Arm Susp. Mower Rear
24	532 10 53-04	Cap Sleeve	190	532 19 65-39	Bolt Shoulder
25	532 17 81-02	Spring, Torsion	192	532 19 84-68	Keeper Belt Idler
26	532 11 04-52	Nut, Push	194	872 14 07-16	Bolt Carr Sqnk 7/16-24 x 2
27	532 18 89-38	Deflector Shield	196	872 14 06-20	Bolt RDHDSQNK3/8-16x2-1/2Gr.5
29	532 13 14-91	Rod, Hinge	241	532 15 29-27	Screw
30	532 17 39-84	Screw, Thdroll Washer Head	242	532 41 55-98	Port Washout
31	532 18 76-90	Washer, Spacer Mower Vented	--	532 18 72-92	Mandrel Assembly (Includes housing, shaft assembly, and bearing only - pulley/nut/washer and blade bolt/washers not included)
32	532 15 35-35	Pulley, Mandrel			
33	532 40 02-34	Nut, Flg. Top Lock			
34	873 68 06-00	Nut Crownlock 3/8-46 unc			
39	532 19 73-80	Pulley, Idler, LH	--	532 19 93-00	Replacement Mower, Complete
43	532 19 60-65	Arm, Idler			
46	532 13 77-29	Screw, Thdroll. 1/4-20 x 5/8			
47	532 19 61-03	Belt Deck Drive			
49	873 90 06-00	Nut, Lock Flg. 3/8-16 unc			
50	872 11 06-16	Bolt Carriage 3/8-16 x 2 Gr. 5			
52	532 19 73-79	Pulley Idler			
58	532 18 73-42	Baffle Right			

NOTE: All component dimensions given in U.S. inches
1 inch = 25.4 mm

**TRACTOR - MODEL NO. YTH2454 (96043005401), PRODUCT NO. 960 43 00-54
MOWER LIFT**

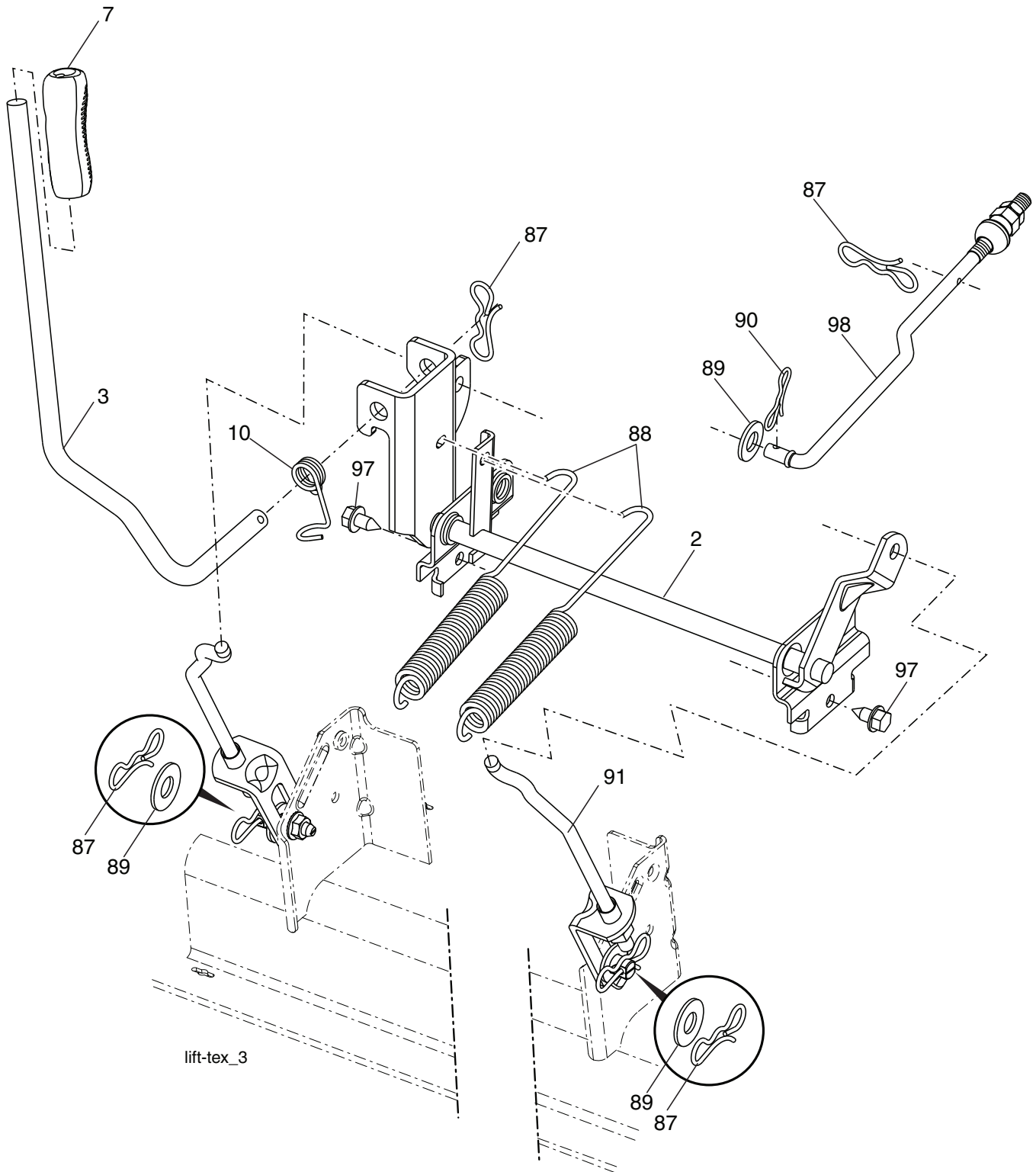

KEY NO.	PART NO.	DESCRIPTION
2	532 19 52-23	Shaft Asm., Lift
3	532 19 52-30	Lever Asm., Lift RH
7	532 41 15-55	Grip, Lever
10	532 19 63-14	Spring Torsion
87	532 19 42-09	Pin Cotter 7/16 Bow Tie Lock
88	532 41 07-10	Spring Lift Assist
89	819 19 19-12	Washer Clear Zinc

KEY NO.	PART NO.	DESCRIPTION
90	532 19 42-08	Pin Cotter 5/16 Bow Tie Lock
91	532 40 34-07	Link Lift Susp Mower Rear
97	817 00 06-12	Screw 3/8-16 x .75
98	532 19 52-64	Link Lift Susp. Front Mower

NOTE: All component dimensions given in U.S. inches
1 inch = 25.4 mm