

PT26D 2009

Spare parts
Ersatzteile
Pièces détachées
Reserve onderdelen
Repuestos
Reservdelar

A PT26D 966 95 70-01
SEAT 510 04 60-01 Rev H

Not Shown:
539 10 75-23 Seat Switch

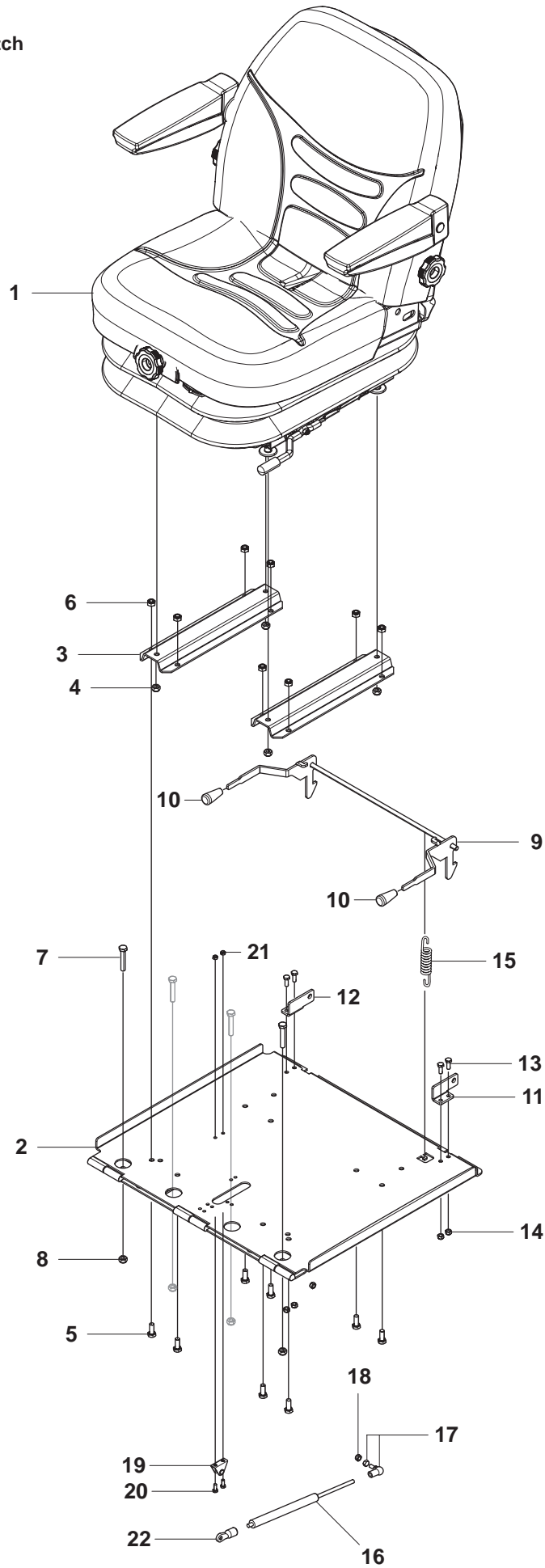

A SEAT

POS.	PART NO .	DESCRIPTION	QTY.
1	510 37 40-01	SEAT	1
2	510 10 73-01	BRACKET, SEAT	1
3	510 44 24-01	BRACKET, SEAT SUSPENSION	2
4	732 21 18-01	LOCK NUT, M8-8	4
5	725 24 51-51	SCREW M6S 8x20 FZ	8
6	732 21 18-01	LOCK NUT, M8-8	8
7	725 24 60-51	SCREW, M6S 8X45 FZB	2
8	732 21 18-01	LOCK NUT, M8-8	2
9	544 35 80-01	HITCH ,SEAT	1
10	535 43 82-01	KNOB	2
11	544 35 86-01	BRACKET, LOCK CLAMP, LEFT	1
12	544 35 86-02	BRACKET, LOCK CLAMP, RIGHT	1
13	725 23 68-51	SCREW, M6X16	4
14	732 21 16-01	LOCK NUT, M6	4
15	544 21 81-03	SPRING, L=50 MM.	1
16	544 46 82-01	SPRING, GAS	1
17	544 93 55-01	BRACKET, ROD END	1
18	732 21 16-01	LOCK NUT, M6	1
19	544 97 19-01	BRACKET, CPL,GAS SPRING	1
20	725 23 27-71	SCREW, M6S 5X12-8.8FZ	2
21	732 21 14-01	LOCK NUT, M5	2
22	544 93 55-01	BRACKET ROD END	1

B PT26D 966 95 70-01
COVER 544 22 22-01 Rev D

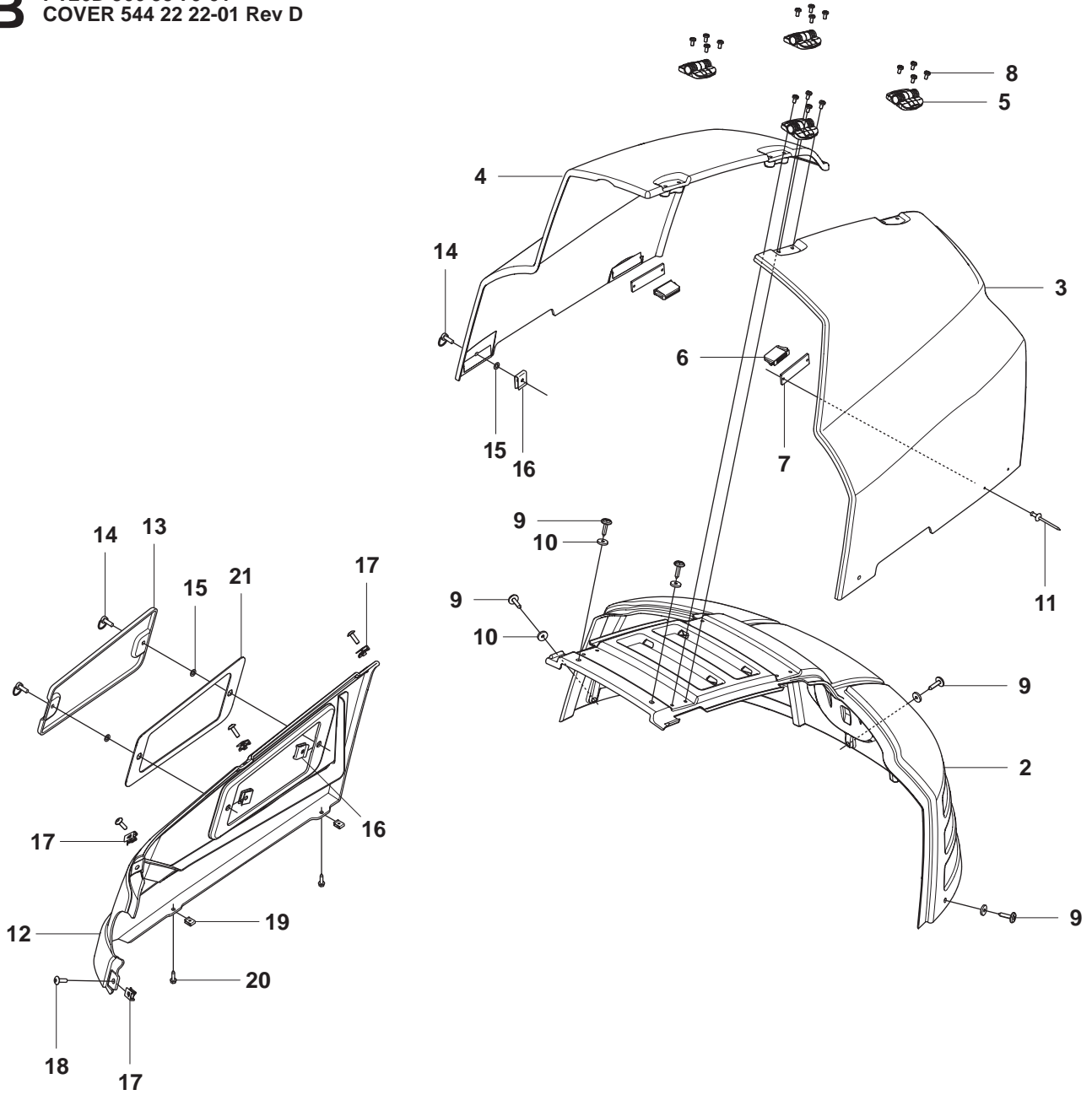

B COVER

POS.	PART NO .	DESCRIPTION	QTY.
2	544 17 73-01	MOTORKÅPA,CENTRE PAR	1
3	522 52 02-01	MOTORKÅPA,SIDE PART	1
4	522 52 02-02	MOTORKÅPA,SIDE PART	1
5	544 25 48-01	GÅNGJÄRN,ENGINE HOOD	4
6	544 25 49-01	MAGNET,ENGINE HOOD	2
7	544 87 01-01	PLÅT,MAGNETIC	2
8	544 29 13-01	SKRUV,TORX 5X10	16
9	506 98 26-02	SKRUV	5
10	506 55 97-01	GUMMIBRICKA	5
11	722 78 29-02	POPNIT 3.2x13.3	4
12	501 04 80-01	KÅPA,CONTROL COVER S	1
13	544 33 27-01	LOCK,FUSE ACCESS	1
14	506 96 35-01	VRIDTAPP	4
15	506 96 36-01	BRICKA	4
16	506 96 37-01	LÅSDON	4
17	535 42 91-01	FJÄDERMUTTER M6	4
18	535 42 58-02	SKRUV,MK6S 6X20 SV	4
19	506 89 20-01	SNABBLÅSMUTTER	2
20	535 41 56-19	FLÄNSSKRUV ST4.8X19	2
21	501 04 79-01	PACKNING,SIDE COVER	1

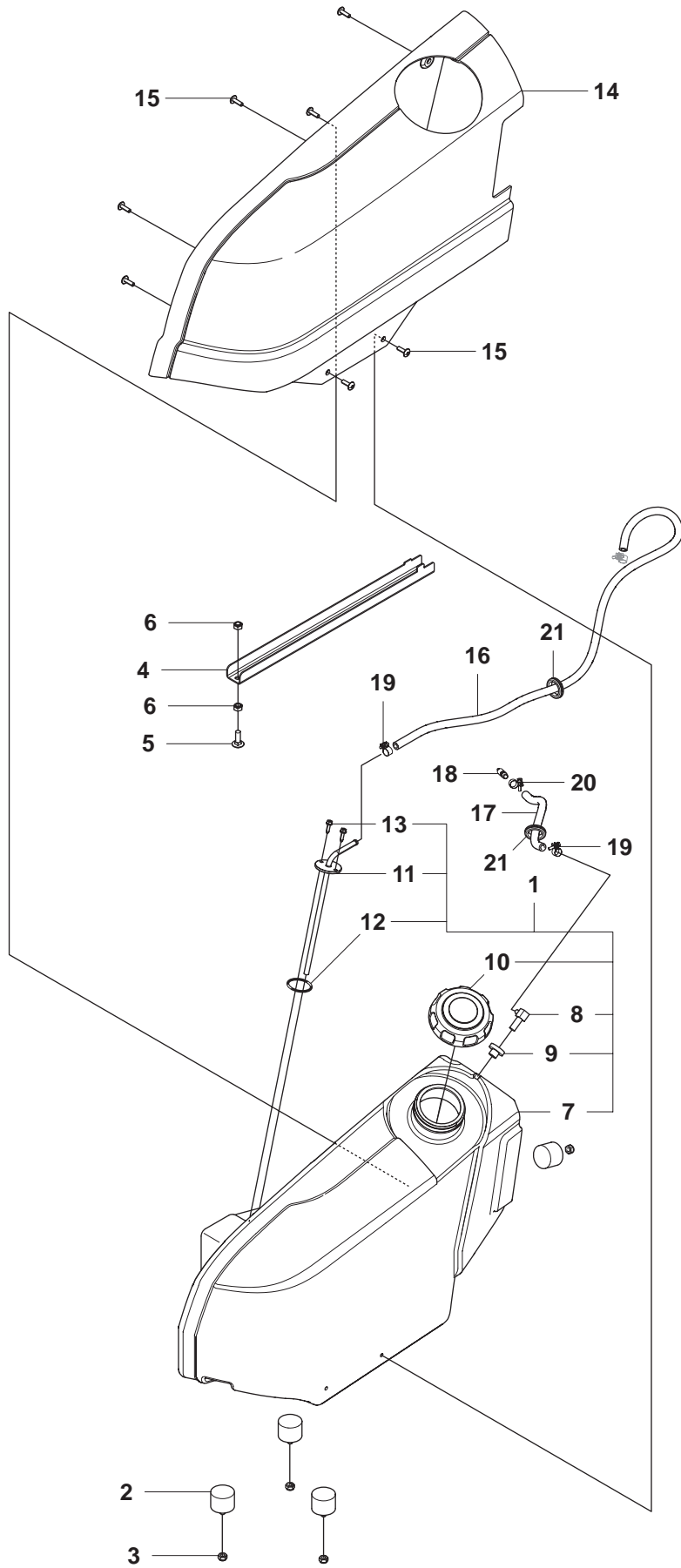

C FUEL SYSTEM

POS.	PART NO .	DESCRIPTION	QTY.
1	522 44 66-01	BRÄNSLETANK KPL	1
2	544 25 21-01	VIBRATIONISOLATOR	4
3	732 21 18-01	LÅSMUTTER,M8-8	4
4	522 02 81-01	BALK,FUEL TANK	1
5	535 42 38-01	SKRUV,MVBF M8X25 GK	1
6	732 21 18-01	LÅSMUTTER,M8-8	2
7	505 14 91-01	BRÄNSLETANK	1
8	539 10 52-44	JOINT	1
9	539 10 52-45	GENOMFÖRING,RUBBER	1
10	539 10 63-30	TANK CAP	1
11	544 24 33-01	ANSLUTNING,FUEL TANK	1
12	740 48 12-02	O-RING 14.67x1.78	1
13	535 41 56-19	FLÄNSSKRUV ST4.8X19	2
14	510 41 34-01	TANKKÅPA,FUEL TANK	1
15	535 42 58-01	SKRUV,MK6S 6X10 SV	7
16	544 28 25-04	BRÄNSLESLANG	1
17	544 28 25-05	BRÄNSLESLANG	1
18	544 36 92-01	ANSLUTNING,REDUCING	1
19	544 28 26-01	SLANGKLÄMMA,FUEL HOS	2
20	544 28 26-02	SLANGKLÄMMA,FUEL HOS	1
21	505 43 52-01	GROMMET	2

D PT26D 966 95 70-01
WHEEL 544 21 15-01 Rev D

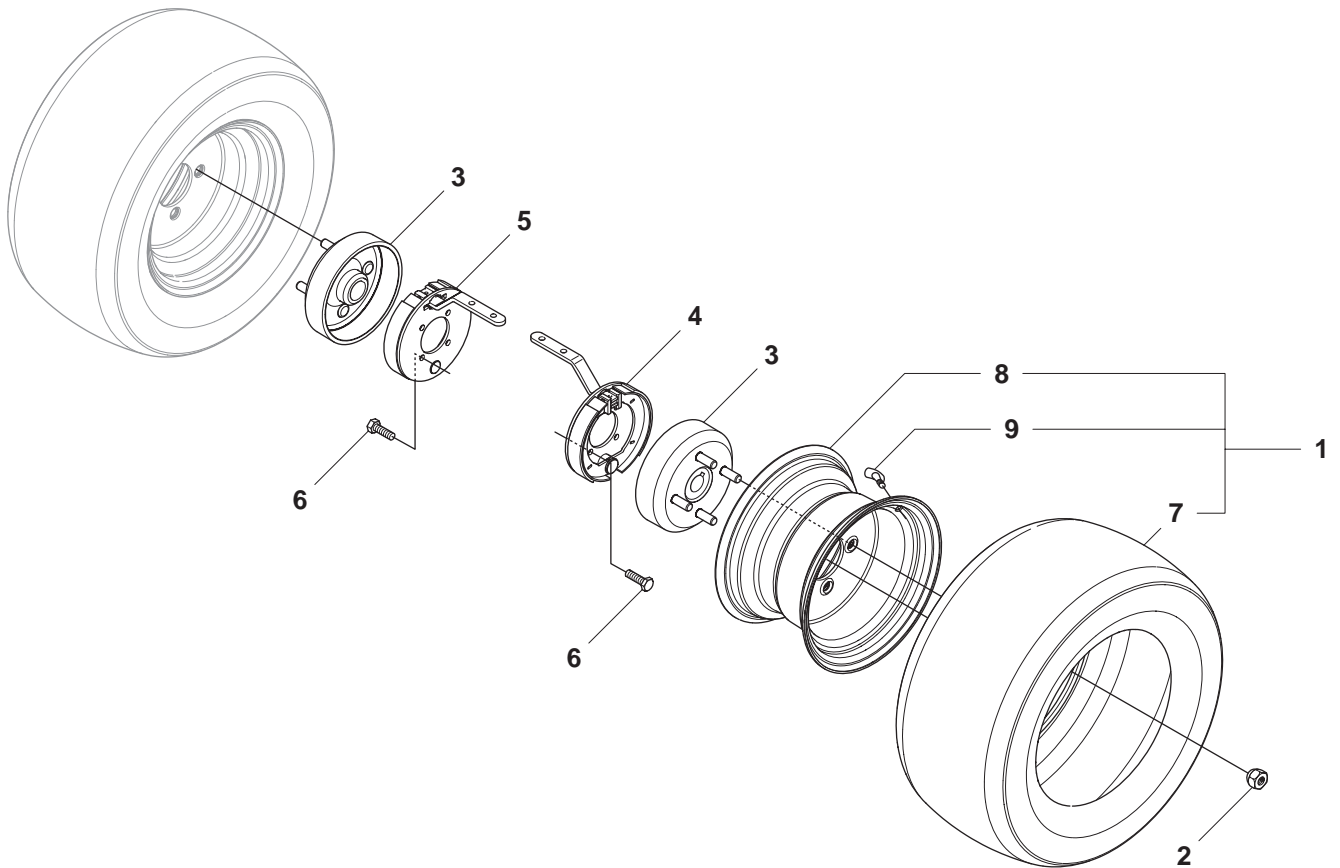
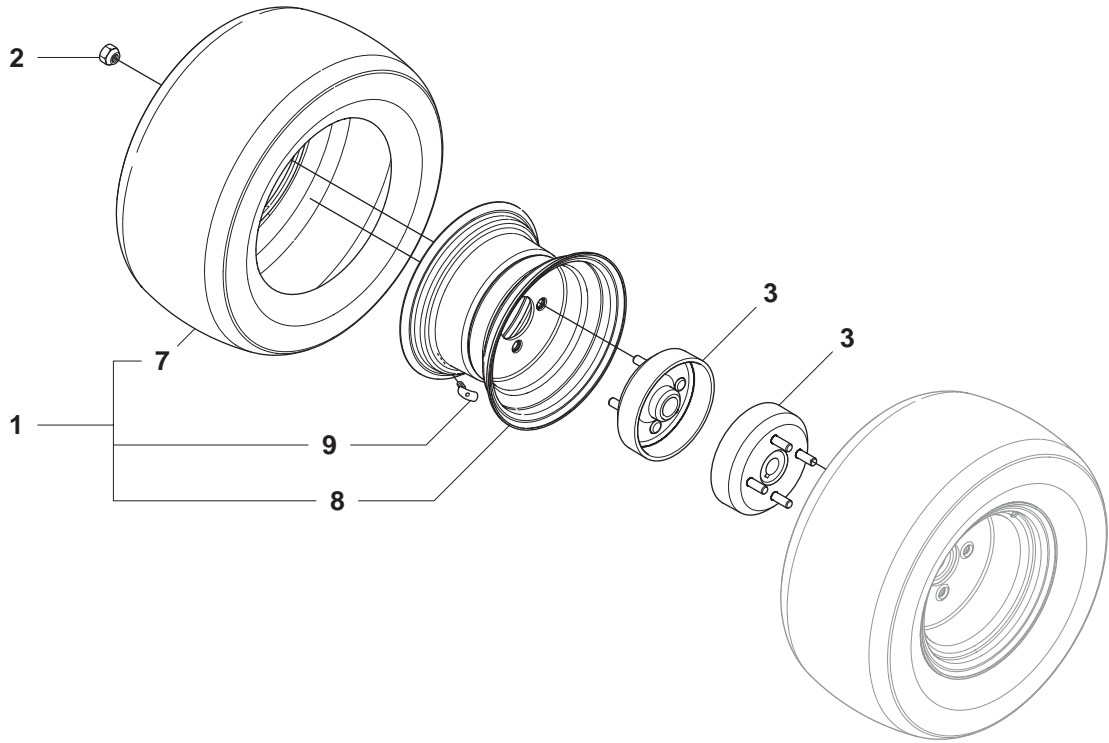

D WHEEL

POS.	PART NO .	DESCRIPTION	QTY.
1	544 21 00-01	HJUL KPL,20X10 HG	4
2	539 10 11-73	NUT	16
3	510 03 74-01	BROMSTRUMMA	4
4	544 93 35-01	BROMS,RIGHT	1
5	544 93 35-02	BROMS,LEFT	1
6	544 33 09-01	SKRUV,5/16X3/4 UNC	8
7	544 21 01-01	TIRE,20X10 HG	4
8	544 21 02-01	FÄLG,6,5 X 10	4
9	506 57 43-01	VENTIL KPL.	4

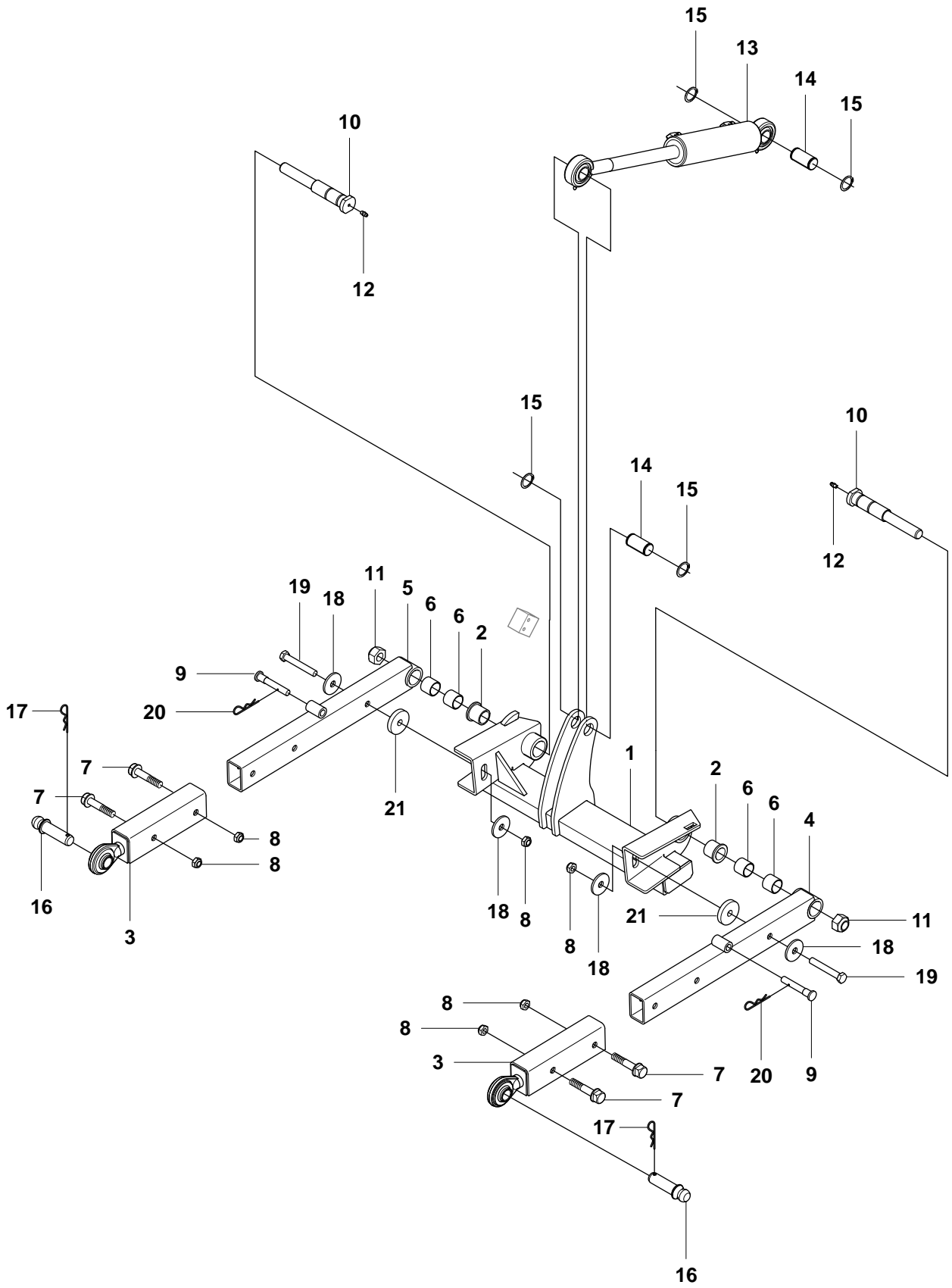
EPT26D 966 95 70-01
LIFTING SYSTEM 510 11 45-01 Rev C

E LIFTING SYSTEM

POS.	PART NO .	DESCRIPTION	QTY.
1	510 11 45-01	BALK,PACKING BEAM	1
2	544 17 41-02	LAGERBUSSNING,FLANGE	2
3	544 22 00-01	REDSKAPSRAM	2
4	544 21 94-01	LYFTARM,LEFT	1
5	544 21 94-02	LYFTARM,RIGHT	1
6	544 21 92-01	LAGERBUSSNING	4
7	725 25 44-71	SKRUV,EHHM 12X60 8.8	4
8	732 25 22-01	MUTTER M12 LOC	6
9	504 88 76-01	SPRINT	2
10	544 21 46-02	BULT,MED KONA	2
11	544 28 13-01	MUTTER LÅSNING,M20 C	2
12	738 88 10-01	SMÖRJNIPPEL,AH M6 FZ	2
13	544 17 61-01	HYDRAULCYLINDER	1
14	544 21 98-01	SPRINT	2
15	735 31 26-00	SPÅRRING SGA 25	4
16	544 21 42-01	BULT,LIFTING ARM	2
17	506 96 66-01	HÄRNÄLSSPRINT 4	2
18	505 43 25-01	WASHER	2
19	725 25 48-51	BOLT, M6 12X80	2
20	721 68 02-51	HAIR PIN 3 FZB	2
21	544 25 32-01	WASHER	2

F PT26D 966 95 70-01
STEERING COLUMN 510 04 59-01 Rev H

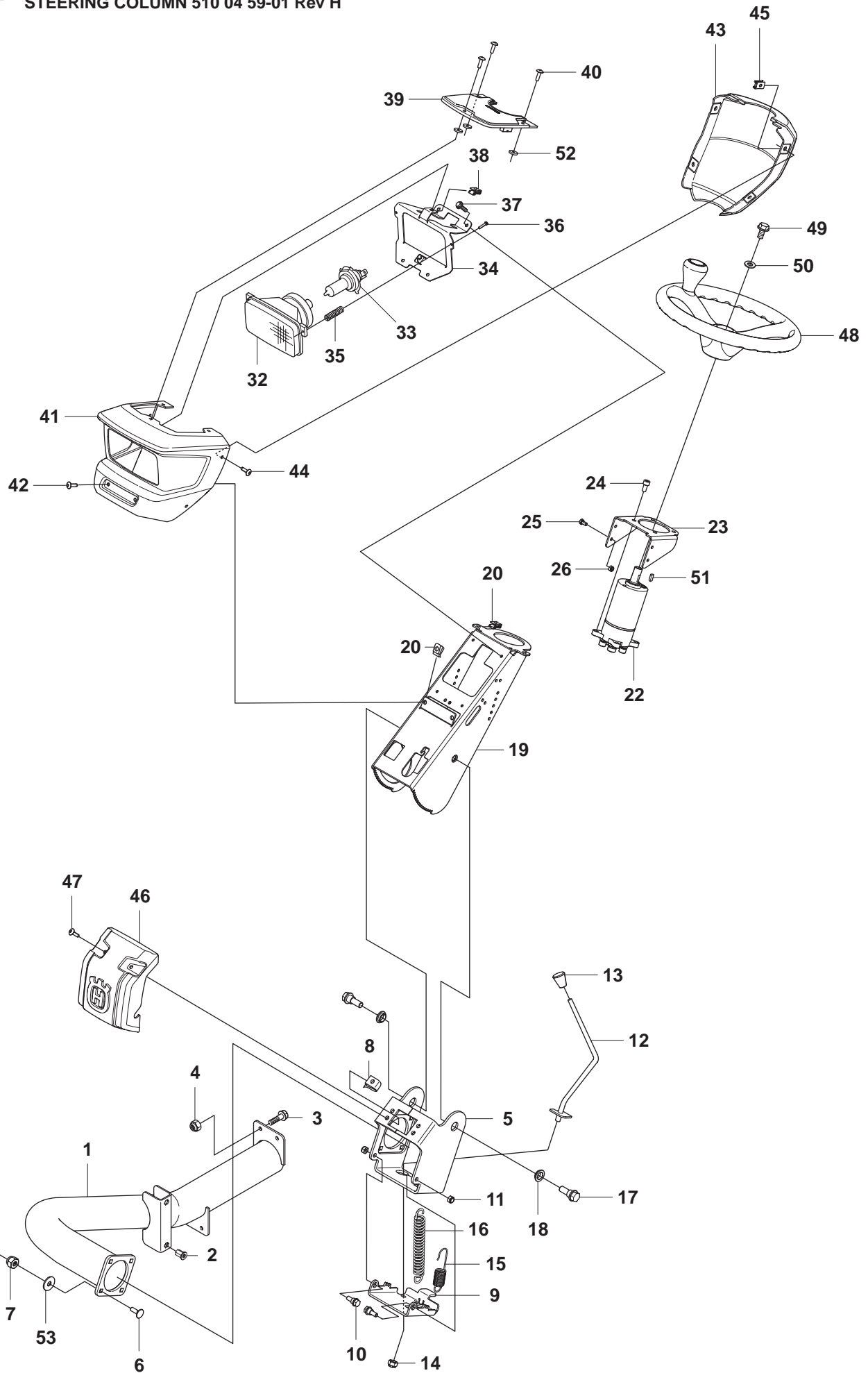

F STEERING COLUMN

POS.	PART NO .	DESCRIPTION	QTY.
1	544 29 70-01	RATTRÖR	1
2	506 91 62-01	BLINDNITMUTTER,M8X16	2
3	506 57 01-03	SKRUV EHHFM,8X16	4
4	732 21 18-01	LÅSMUTTER,M8-8	4
5	544 30 07-01	GAFFEL	1
6	535 42 38-01	SKRUV,MVBF M8X25 GK	4
7	732 21 18-01	LÅSMUTTER,M8-8	4
8	535 42 91-01	FJÄDERMUTTER M6	13
9	544 30 11-01	LÅSBYGEL	1
10	506 59 74-01	ANSATSSKRUV M8	2
11	732 21 18-01	LÅSMUTTER,M8-8	2
12	544 30 02-01	SPÄRRHÄVARM,STEERING	1
13	544 30 00-01	KNOPP	1
14	732 21 20-01	MUTTER,M10 LOC	1
15	504 88 84-01	SPRING	1
16	544 21 81-06	DRAGFJÄDER,L=108	1
17	506 89 58-01	ANSATSSKRUV	2
18	544 29 98-01	BUSSNING	2
19	510 08 91-01	RATTKOLONN	1
20	535 42 91-01	BLINDNITMUTTER,M8X19	1
22	506 06 81-01	SERVOSTYRNING	1
23	521 93 59-01	FÄSTE,POWER STEERING	1
24	725 54 49-01	SKRUE C HC 8X16 BICH	4
25	725 23 68-71	SKRUV EHHM	4
26	732 21 16-01	NUT M6 LOC	4
32	544 30 13-01	STRÅLKASTARE	1
33	544 34 75-01	LAMPA,H4	1
34	544 30 14-01	FÄSTE,HEADLAMP	1
35	544 28 76-03	FJÄDER	2
36	724 12 95-01	SCREW	2
37	725 23 64-61	SKRUV M6x10 TAPTITE	4
38	535 42 91-01	FJÄDERMUTTER M6	2
39	544 30 12-01	INDIKERINGSPANEL	1
40	535 42 58-02	SKRUV,MK6S 6X20 SV	3
41	544 33 28-01	KÅPA,HEAD LAMP	1
42	535 42 58-02	SKRUV,MK6S 6X20 SV	2
43	510 13 13-01	KÅPA,STEERING COLUMN	1
44	535 42 58-02	SKRUV,MK6S 6X20 SV	4
45	535 42 91-01	SPRING NUT	4
46	505 21 44-01	KÅPA,STEERING COLUMN	1
47	535 42 58-02	SKRUV,MK6S 6X20 SV	2
48	544 29 14-01	RATT	1
49	506 57 01-06	SKRUV EHHFM,8X35	1
50	544 22 16-01	BRICKA,8.4X29X3	1
51	735 88 12-00	WOODRUFFKIL,5X6,5	1
52	506 55 97-01	GUMMIBRICKA	3
53	734 11 64-01	BRICKA,BRB 8.4X17	4

G CONTROLS

POS.	PART NO .	DESCRIPTION	QTY.
1	544 25 51-01	HANDTAG KPL	1
2	506 59 74-01	ANSATSSKRUV M8	4
3	732 21 18-01	LÅSMUTTER,M8-8	7
4	544 29 00-01	PEDALPLATTA KPL,PROT	1
5	725 24 62-51	SKRUV M6S 8X55 FZ	2
6	732 21 18-01	LÅSMUTTER,M8-8	2
7	544 28 88-01	PEDALPLATTA	1
8	544 28 94-01	HYDROSTATPEDAL	1
9	535 47 99-01	FOTPLATTA KPL.	1
10	721 43 09-70	PINNE S 5x22	1
11	506 50 62-01	PEDALGUMMI	1
12	535 45 99-01	RULLE	1
13	544 28 91-01	BACKPEDAL	1
14	727 64 59-51	SKRUV RSQM,8X40 8.8	2
15	535 45 95-01	FJÄDER	1
16	506 95 41-01	LAGERBLOCK	8
17	506 80 41-01	PLÅT	4
18	731 21 18-01	MUTTER M6M M8 LOC	4
19	544 33 82-01	DEKAL,PEDAL	1
20	725 24 59-51	SKRUV M6S 8x40 fz	2
21	734 11 64-01	BRICKA,BRB8.4/17X1.6	4
22	506 81 49-09	STÄNG,L=640	1
23	506 78 99-01	VINKELLÄNK DIN 71802	1
24	506 89 76-01	MUTTER V-GÄNGAD FZ	1
25	732 21 20-51	MUTTER M10-LOCK	1
26	506 95 17-01	LÄNKHUVUD,M10 HÖ INV	1
27	725 24 95-71	SKRUV M6S M10X30 FZ	1
28	732 21 20-51	MUTTER M10-LOCK	1
29	505 14 92-01	SHEET	1
30	505 14 95-01	CONTROL UNIT	1
31	725 24 60-71	SCREW	1
32	732 21 18-01	LÅSMUTTER M8	1
33	725 24 53-51	SKRUV	2
47	544 35 76-01	WIRE KPL,BRAKE LEFT	1
48	544 35 76-02	WIRE KPL,BRAKE RIGHT	1
49	506 94 63-01	BROMSFJÄDER FRÄMRE	2
50	725 24 60-71	SKRUV M6S 8X45 FZ	2
51	506 54 25-01	FJÄDER,20X2 L=62	2
55	535 47 52-45	SCREW, M6X45	2
56	732 21 16-01	MUTTER M6 LOC	2
59	522 45 42-01	DIFFERENTIALPEDAL KP	1
66	725 23 68-51	SKRUV,M6S 6X55-8.8	2
67	732 21 16-01	MUTTER M6 LOC	2
68	734 11 56-01	BRICKA BRB 6.7X14 FZ	2
75	521 90 27-01	PARKERINGSBROMS	1
77	544 29 03-01	LÄNK	2
79	506 98 61-01	GLIDLAGER	2
80	544 27 94-01	HYLSA	2
81	725 25 43-51	SKRUV EHHM,12X55 8.8	1

82	732 25 22-01	MUTTER M12 LOC	2
83	734 11 80-41	BRICKA,13/37X3 FZB	2
84	725 23 31-51	SKRUV,M6S 5X20-8.8FZ	3
85	732 21 14-01	LÅSMUTTER, M5	3
86	725 25 43-51	SCREW, M12X55 8.8	1
87	521 90 31-01	BRACKET LEVER	1
88	521 90 29-01	BRACKET	1
89	521 90 35-01	KNOPP	1
90	521 90 36-01	LINK	1
91	506 59 74-01	ANSATSSKRUV M8	2
92	732 21 18-01	LÅSMUTTER	2
93	731 23 16-01	NUT	1
94	535 42 91-01	SPRING NUT	1
95	731 23 16-01	MUTTER	1
96	725 23 72-71	SKRUV	1
97	506 93 83-01	GASFJÄDER	2

H1

PT26D 966 95 70-01
CHASSI 510 04 56-01 Rev J

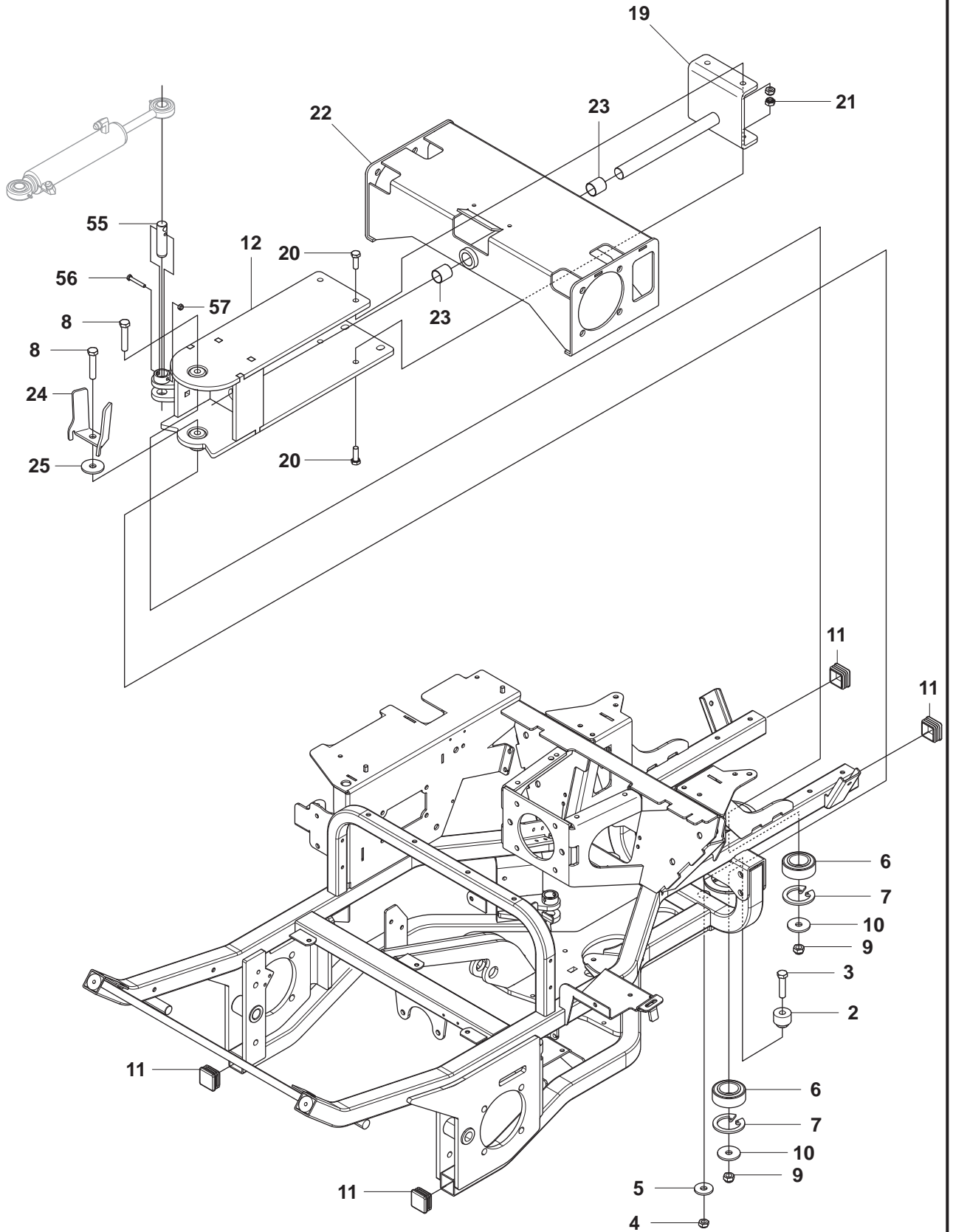

H2

PT26D 966 95 70-01
CHASSI 510 04 56-01 Rev J

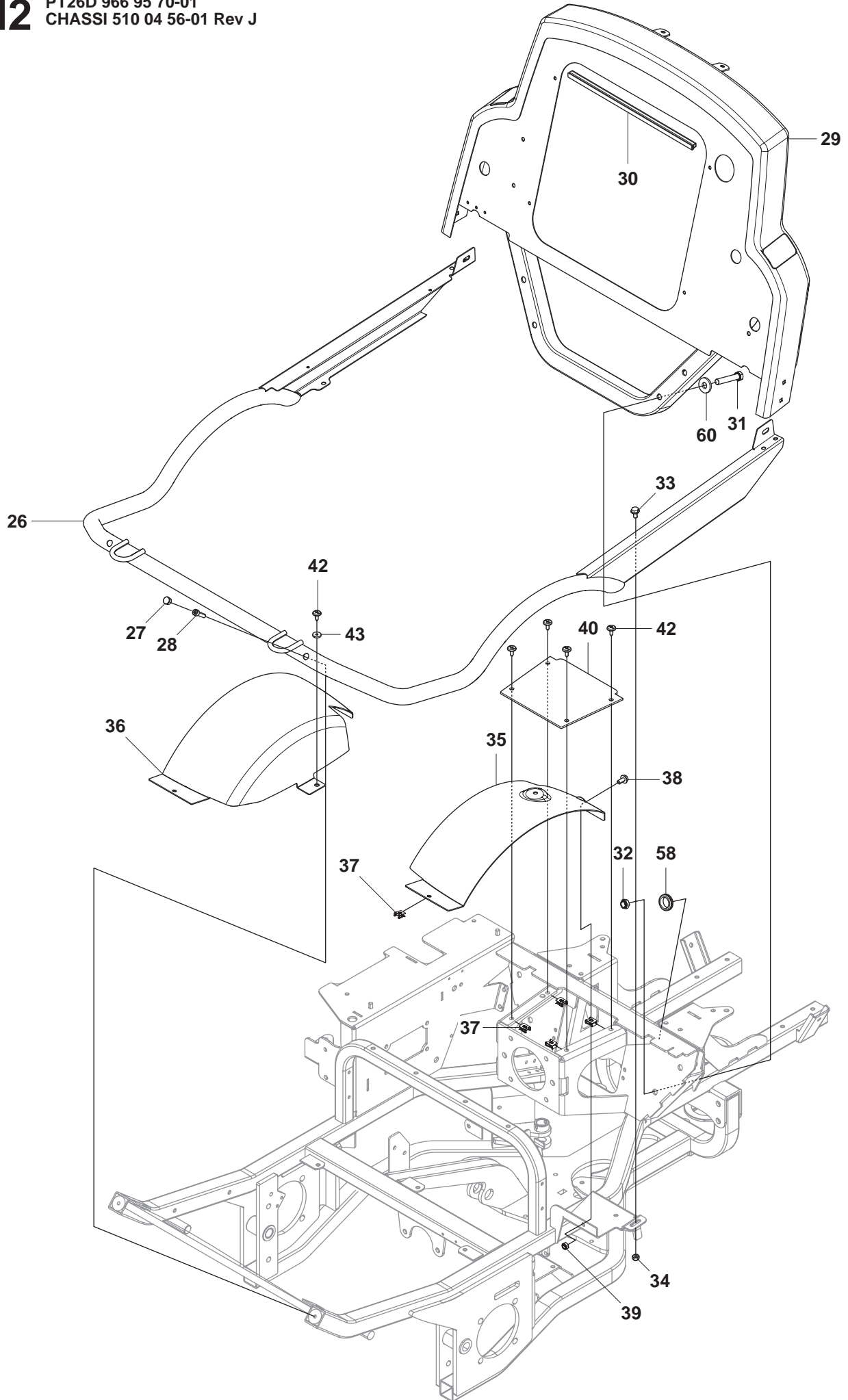

H CHASSIS

POS.	PART NO .	DESCRIPTION	QTY.
2	544 18 91-01	STOPPHYLSA,STEERING	1
3	725 25 42-51	SKRUV EHHM,12X50 8.8	1
4	732 25 22-01	MUTTER M12 LOC	1
5	535 42 92-01	BRICKA	1
6	738 22 07-19	KULLAGER,6207 2RSI	2
7	544 25 29-01	SPÄRRING,SGH 72	2
8	725 25 44-71	SKRUV,EHHM 12X60 8.8	2
9	732 25 22-01	MUTTER M12 LOC	2
10	544 25 32-01	BRICKA,13X45X4	1
11	544 25 41-01	PLUGG,TUBE	4
12	544 18 79-01	RAM,REAR	1
19	544 18 92-01	PENDELAXEL	1
20	725 24 95-71	SKRUV M6S M10X30 FZ	4
21	732 21 20-51	MUTTER M10-LOCK	4
22	544 18 87-01	BAKAXEL	1
23	506 98 61-01	GLIDLAGER	2
24	501 98 75-01	STYRPLÅT,HYDRAULIC H	1
25	734 11 77-71	BRICKA 13/20X2 FZ	1
26	510 16 44-01	FRONTRÖR	1
27	544 24 19-01	PLUGG	2
28	725 54 55-01	SCREW,8X30 8.8 FZB	2
29	506 60 78-01	TORPEDPLÅT	1
30	544 32 92-01	TÄTNINGSLIST	1
31	725 25 45-51	SKRUV EHHM,12X65 8.8	4
32	732 25 22-01	MUTTER M12 LOC	4
33	506 57 01-03	SKRUV EHHFM,8X16	2
34	732 21 18-01	LÅSMUTTER,M8-8	1
35	510 09 33-01	STÄNKSKÄRM,LEFT	1
36	510 09 34-01	STÄNKSKÄRM,RIGHT	1
37	535 42 91-01	FJÄDERMUTTER M6	2
38	506 57 01-03	SKRUV EHHFM,8X16	2
39	732 21 18-01	LÅSMUTTER,M8-8	1
40	510 06 57-01	SKYDDSPÅT	1
42	506 98 26-01	SKRUV	6
43	506 55 97-01	GUMMIBRICKA	2
44	510 17 40-01	MOTORBÅGE,PT26D	1
45	727 64 59-51	SKRUV EHHFM,8X35	4
46	544 23 42-01	STÖD,ENGINE FRAME	2
47	506 57 01-05	SKRUV EHHFM,8X25	4
48	732 21 18-01	LÅSMUTTER,M8-8	8
49	510 09 96-01	FOTPLATTA	1
50	506 98 26-01	SKRUV	7
51	506 55 97-01	GUMMIBRICKA	7
52	535 42 91-01	FJÄDERMUTTER M6	1
53	506 57 01-03	SCREW	4
55	505 39 61-01	AXEL; Ø20,CYLINDER	2
56	725 23 78-51	SKRUV M6X40 8.8 FZB;	2
57	732 21 16-01	LÅSMUTTER M6;	2
58	505 43 52-01	GROMMET	1
60	734 11 80-41	BRICKA	4

J1

PT26D 966 95 70-01
ENGINE 510 04 57-01 Rev M

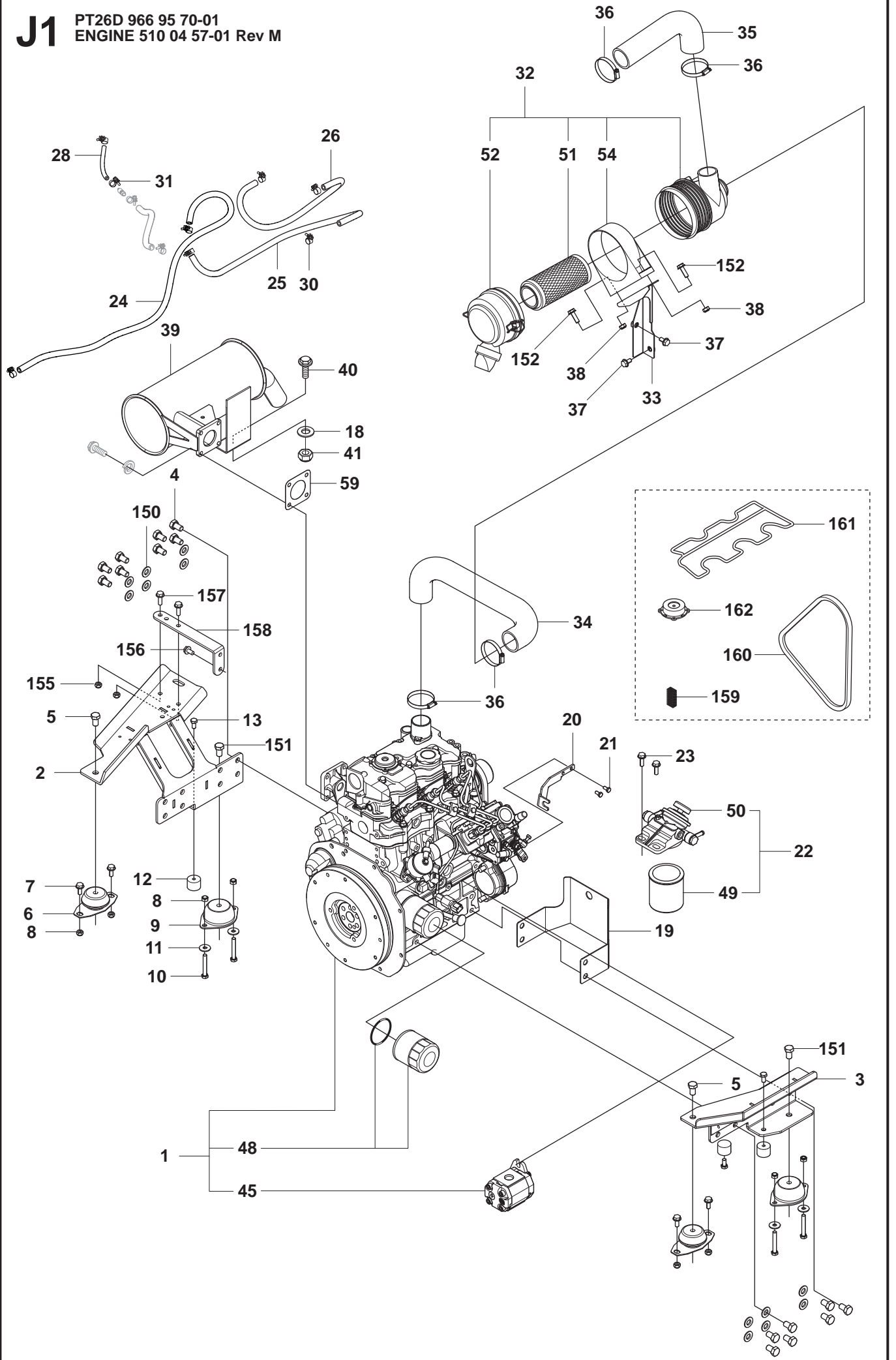

J2

PT26D 966 95 70-01
ENGINE 510 04 57-01 Rev M

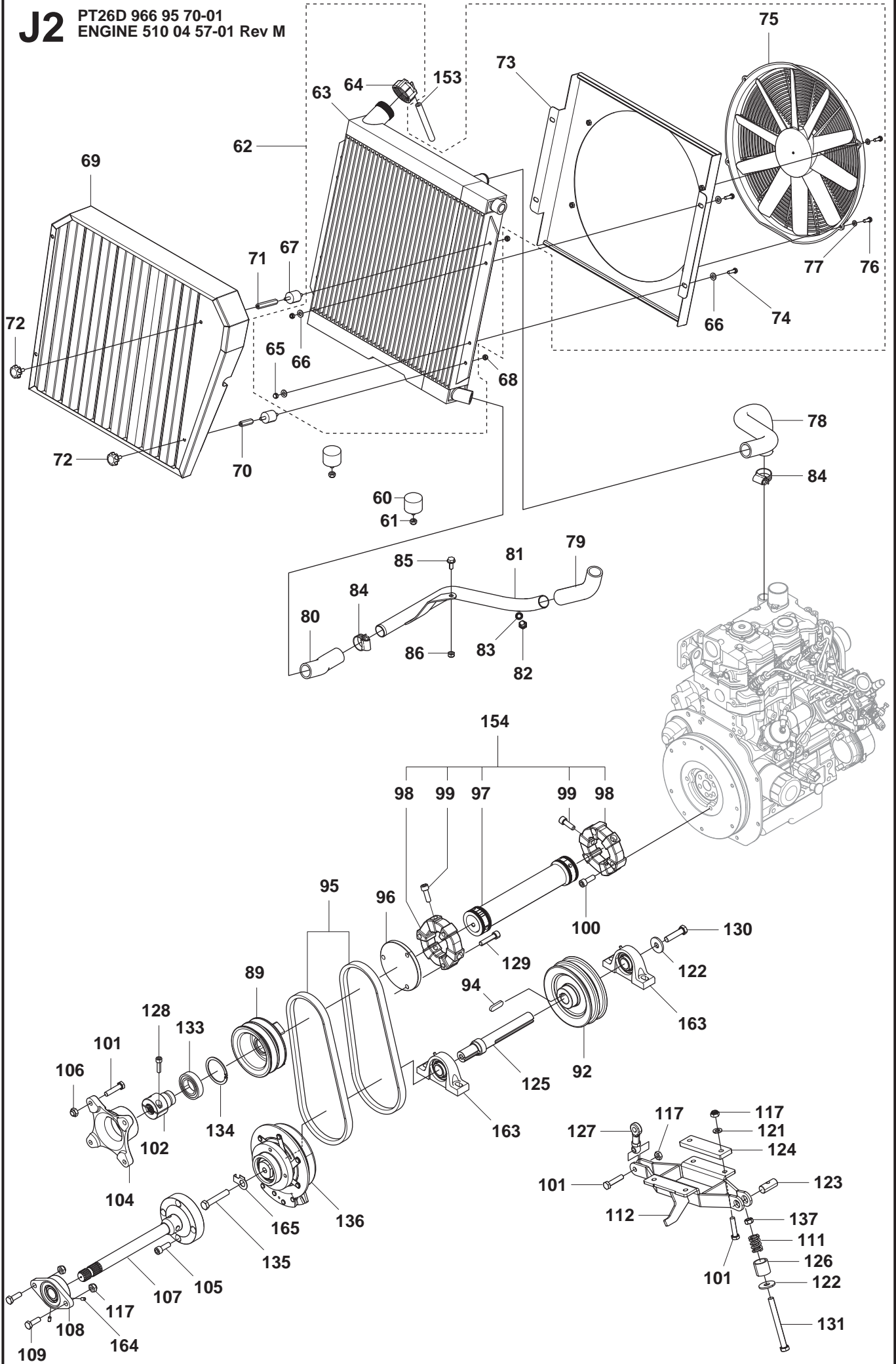

J ENGINE

POS.	PART NO .	DESCRIPTION	QTY.
1	510 19 25-01	MOTOR,PERKINS 403D-1	1
2	504 85 45-01	MOTORINFÄSTNING,RIGH	1
3	510 22 06-01	MOTORINFÄSTNING,LEFT	1
4	544 25 19-01	SKRUV EHHM,12X1.25X2	15
5	725 25 32-71	SCREW,12X20	2
6	544 19 13-03	VIBRATIONISOLATOR,E	2
7	506 57 01-04	SKRUV EHHFM,8X20	4
8	732 21 18-01	LÅSMUTTER,M8-8	8
9	544 19 13-02	VIBRATIONISOLATOR,E	2
10	725 24 62-51	SKRUV M6S 8X55 FZ	4
11	734 11 64-01	BRICKA,BRB 8.4X17	4
12	544 25 21-02	VIBRATIONISOLATOR	4
13	506 57 01-03	SKRUV EHHFM,8X16	4
18	734 11 64-41	BRICKA SRKB 8.4/25X2	1
19	544 44 32-01	SKYDDSPLÅT,REAR	1
20	515 98 08-01	FÄSTE,THROTTLE WIRE	1
21	725 23 66-51	SKRUV EHHM,6X12 8.8	2
22	544 25 16-01	BRÄNSLEFILTER,DIESEL	1
23	506 57 01-05	SKRUV EHHFM,8X25	2
24	544 28 25-01	BRÄNSLES LANG	1
25	544 28 25-02	BRÄNSLES LANG	1
26	544 28 25-03	BRÄNSLES LANG	1
28	544 28 25-05	BRÄNSLES LANG	1
30	544 28 26-01	SLANGKLÄMMA,FUEL HOSE	6
31	544 28 26-02	HOSE CLAMP	1
32	544 18 02-01	LUFTRENARE	1
33	544 33 98-01	FÄSTE KPL,AIRCLEANER	1
34	544 18 04-01	SLANG,AIR INTAKE	1
35	544 18 05-02	SLANG,AIR INTAKE	1
36	544 20 27-03	SLANGKLÄMMA	4
37	506 57 01-03	SKRUV EHHFM,8X16	2
38	732 21 18-01	LÅSMUTTER,M8-8	2
39	522 44 65-01	LJUDDÄMPARE	1
40	506 57 01-04	SKRUV EHHFM,8X20	1
41	732 21 18-01	LÅSMUTTER,M8-8	1
45	510 22 65-01	HYDRAULPUMP	1
48	544 29 12-01	FILTER,DIESEL ENGINE	1
49	544 28 28-01	BRÄNSLEFILTER,FILTER	1
50	544 28 29-01	FILTERHÅLLARE,WITH P	1
51	544 28 30-01	LUFTFILTER	1
52	544 28 32-01	LUFTFILTERHALVA,GABE	1
54	544 18 03-01	FÄSTE,AIR CLEANER	1
59	544 18 07-01	PACKNING	1
60	544 25 21-01	VIBRATIONISOLATOR	2
61	732 21 18-01	LÅSMUTTER,M8-8	2
62	501 01 78-01	KYLARELEMENT KPL	1
63	501 01 79-01	KYLARELEMENT	1
64	544 25 61-01	LOCK,RADIATOR	1
65	732 21 16-01	MUTTER M6 LOC	4

66	734 11 63-01	BRICKA,BRB8.4/16X1.6	8
67	544 19 00-01	VIBRATIONISOLATOR,R	4
68	732 21 16-01	MUTTER M6 LOC	4
69	544 28 08-01	GALLER,COOLER	1
70	544 34 28-01	DISTANSHYLSA,6X35	2
71	544 34 28-02	DISTANSHYLSA,6X60	2
72	544 34 48-01	VRED,M6X15	4
73	540 06 28-01	FLÄKTKÅPA,ELECTRIC F	1
74	725 23 70-71	SKRUV, M6X20	4
75	544 18 10-01	ELFLÄKT	1
76	725 23 68-51	SKRUV M6S 6X16 FZ	4
77	734 11 52-01	BRICKA,6.4/12X1.6 FZ	4
78	544 18 11-01	SLANG,COOLING WATER	1
79	544 18 13-01	SLANG,COOLING WATER	1
80	544 18 14-01	SLANG,COOLING WATER	1
81	544 18 98-01	RÖR,COOLING WATER	1
82	725 24 87-71	SKRUV EHHM,M10X12 FZ	1
83	535 43 72-02	GUMMISTÅLBRICKA,M10	1
84	544 20 27-02	SLANGKLÄMMA	6
85	506 57 01-04	SKRUV EHHFM,8X20	1
86	732 21 18-01	LÅSMUTTER,M8-8	1
89	505 02 04-01	PULLEY-PTO	1
92	506 00 96-01	REMSKIVA,PTO	1
94	504 81 35-01	PLATTKIL,6X6X40	1
95	506 00 75-01	REM,PTO	1
96	515 98 35-01	FLÄNS,ENGINE SIDE	1
97	515 98 33-01	SHAFT	1
98	515 98 34-01	RUBBER RING	2
99	725 54 95-01	SCREW IHSETM, 10x30 FZB	6
100	502 23 36-01	SKRUV IHSCM,10X30	3
101	725 25 00-51	SKRUV IHSCM,10X60	9
102	510 09 07-01	SHAFT	1
104	506 04 32-01	FLÄNS,PUMP SIDE	1
105	502 23 36-01	SCREW	4
106	732 21 20-51	MUTTER M10-LOCK	4
107	506 04 19-01	AXEL,PTO	1
108	544 19 10-01	LAGERENHET,FYTB 25TF	2
109	725 24 95-71	SKRUV M6S M10X30 FZ	2
110	732 21 20-01	MUTTER,M10 LOC	4
111	510 17 07-01	FJÄDER	2
112	506 04 27-01	BEARING CAGE	1
117	732 21 20-51	LÅSMUTTER,M8-8	1
121	734 11 72-01	WASHER	4
122	535 42 92-01	WASHER	2
123	510 16 76-01	PIN	1
124	510 14 60-01	DISTANCE	1
125	506 04 26-01	SHAFT	1
126	522 94 69-01	SLEEVE	1
127	506 95 17-01	ROD END	1
128	725 54 55-01	SCREW	2
129	502 23 36-02	SCREW IHSCM, 10X30	3
130	725 25 42-51	M12X50	1
131	725 25 15-71	SCREW	1

133	522 66 44-01	BALL BEARING	1
134	522 66 43-01	CIRCLIP	1
135	522 68 00-01	SCREW EHHM	1
136	506 04 24-01	CLUTCH	1
137	731 23 20-51	NUT	1
150	734 11 77-71	BRICKA 13/20X2 FZ	12
151	725 24 93-71	SKRUV M6S 10x25 FZ	2
152	506 57 01-05	SKRUV EHHFM,8X25	2
153	506 94 67-02	BRÄNSLESLANG	1
154	515 98 32-01	KOPPLING,FLEXIBLE	1
155	732 21 18-01	LOCK NUT	2
156	506 57 01-03	SCREW	2
157	506 57 01-05	SCREW	2
158	505 39 68-01	BRACKET	1
159	544 91 35-01	FÖRFILTER	1
160	544 91 36-01	GENERATORREM	1
161	544 91 37-01	VENTILKÅSPACKNING	1
162	544 91 38-01	VEVHUSVENTIL	1
163	506 04 36-01	SY-LAGERENHETER	2
164	522 80 58-01	LOCKING SCREW	2
165	575 81 36-01	LOCKING TAB WASHER	1

K1

PT26D 966 95 70-01
ELECTRIC 510 04 62-01 Rev F

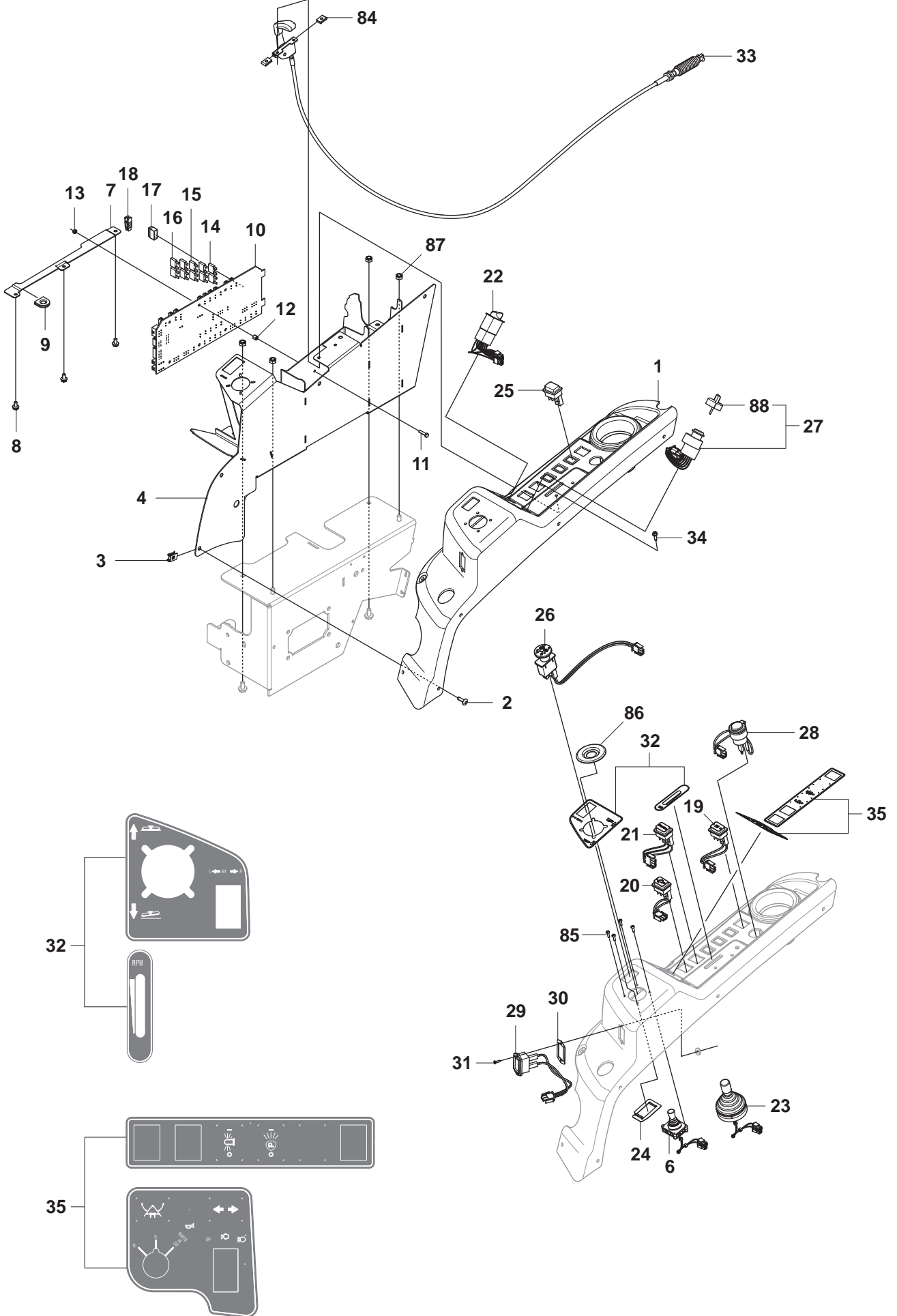

K2

PT26D 966 95 70-01
ELECTRIC 510 04 62-01 Rev F

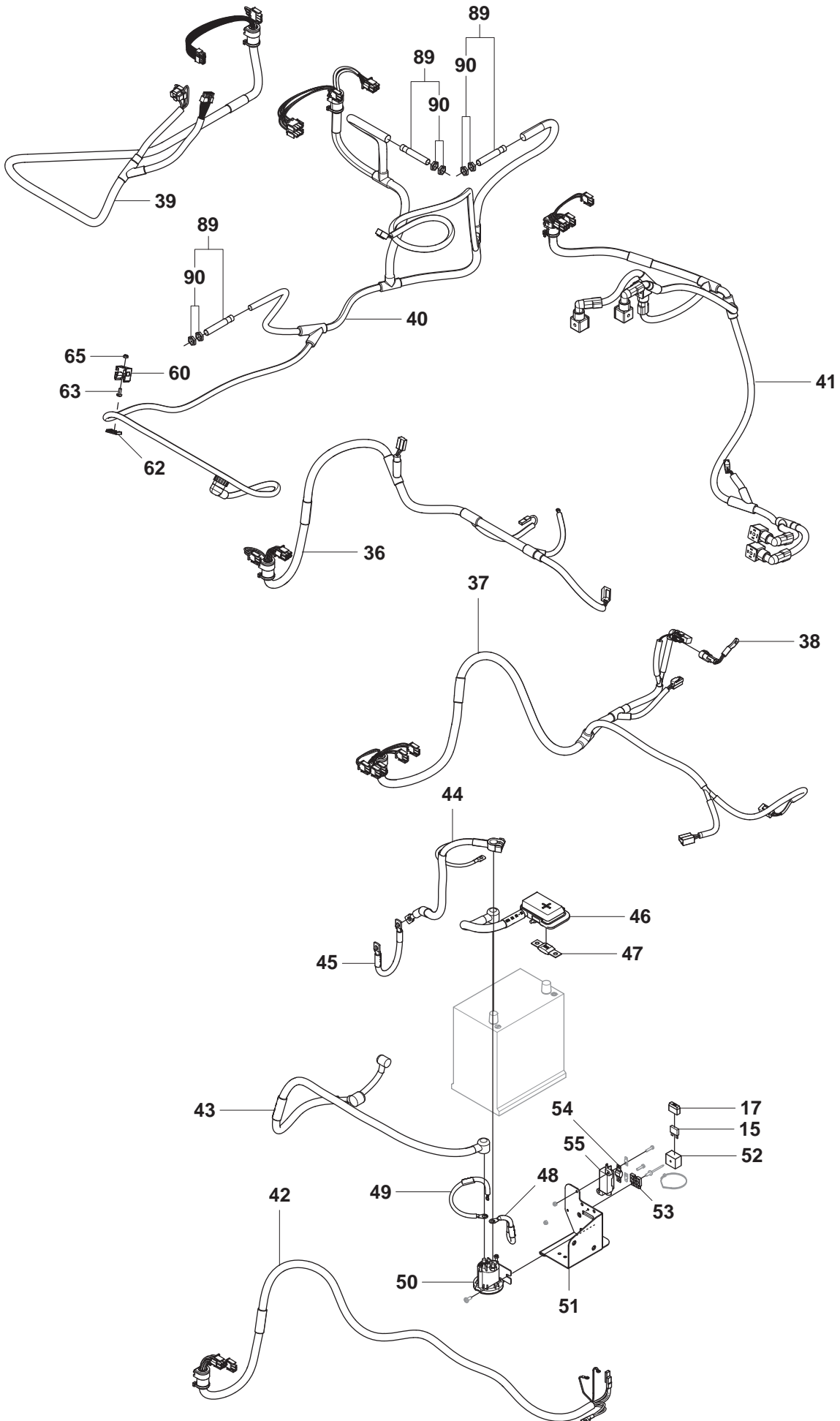

K3

PT26D 966 95 70-01
ELECTRIC 510 04 62-01 Rev F

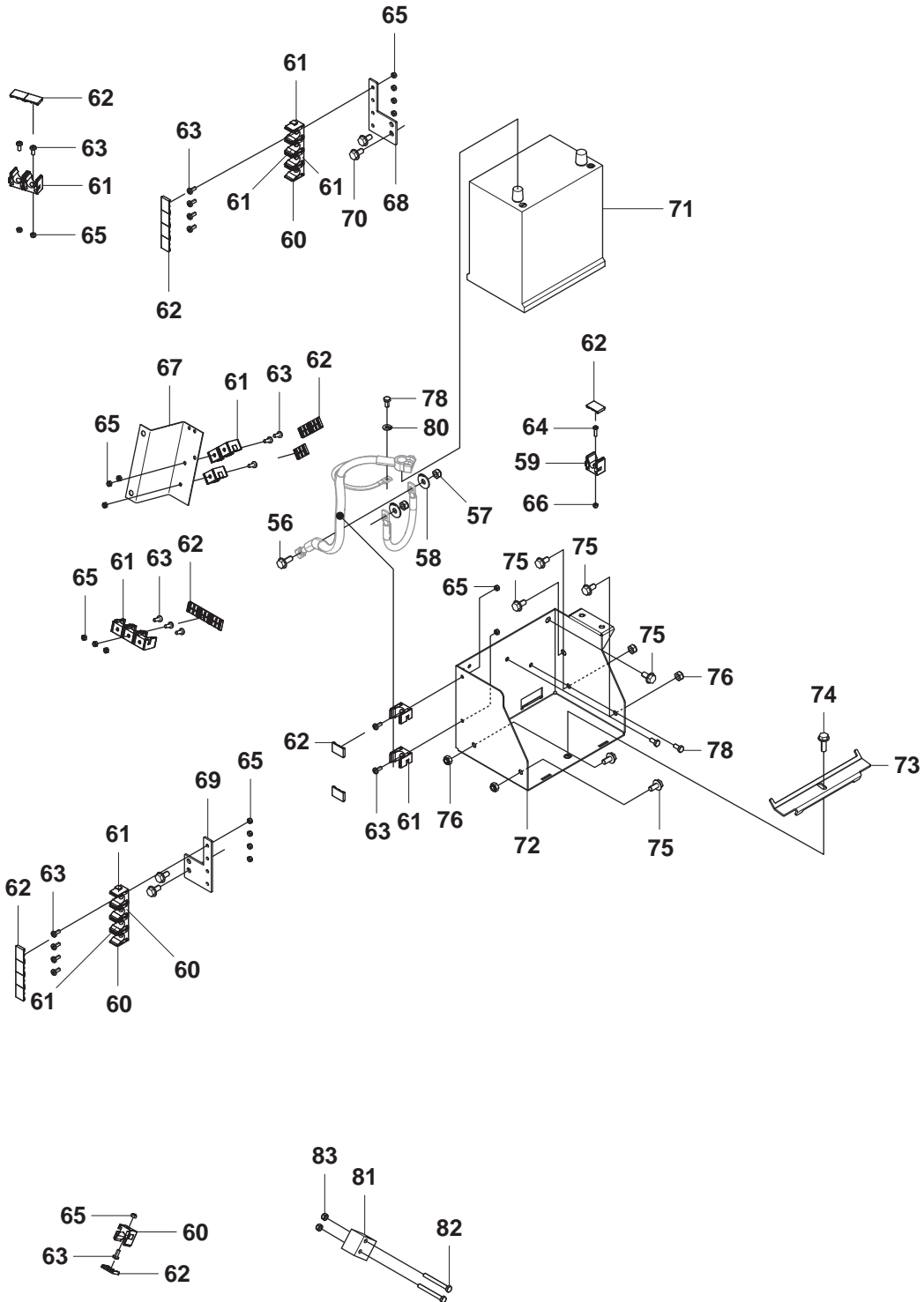

K ELECTRIC

POS.	PART NO .	DESCRIPTION	QTY.
1	540 05 92-01	REGLAGEKÅPA	1
2	535 42 58-02	SKRUV,MK6S 6X20 SV	5
3	535 42 91-01	FJÄDERMUTTER M6	5
4	510 16 94-01	FÄSTE KPL,CONTROL PA	1
6	510 44 16-01	JOYSTICK, APEM	1
7	522 02 48-01	PLÅT,CONTROL PANEL L	1
8	535 47 52-12	SKRUV EHHFM,6X12 FZB	3
9	544 38 15-01	BUSSNING,BLIND	4
10	544 98 33-01	STYRKORT,ELECTRONIC	1
11	725 23 31-51	SKRUV,M6S 5X20-8.8FZ	6
12	544 33 78-01	MUTTER,5X8	6
13	732 21 14-01	LÅSMUTTER, M5	6
14	544 32 43-01	FUSE 7,5 amp.	1
15	544 32 43-02	FUSE 10 amp.	8
16	544 32 43-04	FUSE 20 amp.	2
17	502 08 45-01	COVER	10
18	504 00 81-01	KLÄMMA,FUSE EXTRACTO	1
19	544 31 21-01	BRYTARE,12V	1
20	544 31 24-01	BRYTARE,HIGH SPEED	1
21	544 31 25-01	BRYTARE,FLOATING	1
22	544 31 34-01	BRYTARE,HEAD LAMP	1
23	544 31 55-01	JOYSTICK, CALDARO	1
24	544 40 43-01	LÅSBRICKA,PTO	1
25	504 06 13-01	BRYTARE, BLIND	5
26	544 31 37-01	BRYTARE,PTO	1
27	544 31 52-01	NYCKELBRYTARE,ASSY	1
28	544 31 50-01	UTTAG,12 V	1
29	544 31 51-01	TIMMÄTARE,ASSY	1
30	540 05 57-01	BRICKA,HOUR METER	1
31	722 78 29-02	POPNIT 3.2x13.3	2
32	522 45 74-01	DEKAL,KIT CONTROL PA	1
33	544 25 54-01	GASHANDTAG KPL	1
34	535 41 56-19	FLÄNSSKRUV ST4.8X19	2
35	522 45 75-01	DEKAL,KIT CONTROL PA	1
36	510 44 17-01	KABLAGE,ENGINESTART	1
37	521 91 00-01	KABLAGE,GENERATOR	1
38	544 36 80-01	SENSOR,ENGINE TEMPER	1
39	544 32 24-01	KABLAGE,INDICATION	1
40	522 43 73-01	KABLAGE,SENSOR FRONT	1
41	521 91 01-01	KABLAGE,HYDRAULICS	1
42	544 36 98-01	KABLAGE,POWER RELAY	1
43	544 37 28-01	KABLAGE, START ENGINE	1
44	544 32 35-01	KABLAGE,BATTERY -	1
45	544 32 37-01	JORDKABEL	1
46	544 32 32-01	KABLAGE, BATTERY +	1
47	544 36 96-01	FUSE, 125 AMP.	1
48	544 36 97-01	KABLAGE, FUSE POWER	1
49	501 98 11-01	KABLAGE, FUSE POWER	1
50	521 92 68-01	RELA, POWER	1
51	544 33 97-01	BRACKET, POWER RELÄ	1
52	504 00 63-01	HOLDER, FUSE	1
53	501 00 75-01	BRACKET, FUSE HOLDER	1

54	501 96 55-01	FUSE, 50 AMP.	1
55	501 01 40-01	HOLDER, FUSE.50 AMP.	1
56	506 57 01-04	SKRUV EHHFM,8X20	1
57	732 21 18-01	LÅSMUTTER,M8-8	2
58	734 11 64-01	BRICKA,BRB 8.4X17	2
59	544 32 14-01	HÅLLARE, 7,5	1
60	544 32 14-02	HÅLLARE,10	4
61	544 32 14-03	HÅLLARE,13	12
62	544 32 15-01	HÅLLARE,LID	16
63	544 29 13-02	SKRUV,TORX 5X12	16
64	544 29 13-03	SKRUV TORX, 4x16	1
65	732 21 14-01	LÅSMUTTER, M5	16
66	732 21 12-01	LOCKNUT, M4	1
67	544 37 31-01	FÄSTE,WIRING	1
68	544 33 51-02	FÄSTE,WIRING	1
69	544 33 51-01	FÄSTE,WIRING	1
70	506 57 01-03	SKRUV EHHFM,8X16	4
71	544 28 85-01	BATTERI	1
72	544 33 37-01	BATTERILÅDA	1
73	544 33 38-01	FÄSTE,BATTERY	1
74	506 57 01-05	SKRUV EHHFM,8X25	1
75	506 57 01-03	SKRUV EHHFM,8X16	6
76	732 21 18-01	LÅSMUTTER,M8-8	4
78	725 23 66-71	SKRUV EHHM,6X12 8.8	4
80	734 11 56-01	BRICKA BRB 6.7X14 FZ	1
81	544 26 94-01	FÄSTE,SENSOR LIFT	1
82	725 23 81-51	SKRUV,M6S 6X55-8.8	2
83	732 21 16-01	MUTTER M6 LOC	2
84	733 78 40-23	SNABBLÅSMUTTER	2
85	503 21 28-10	SCREW 3,5X9,5	4
86	510 17 42-01	WASHER,JOYSTICK	1
87	732 21 18-01	NUT	4
88	535 47 60-01	KEY	1
89	522 61 25-01	SENSOR	3
90	522 61 76-01	NUT	6

L1

PT26D 966 95 70-01
HYDRAULIC 510 04 46-01 Rev M

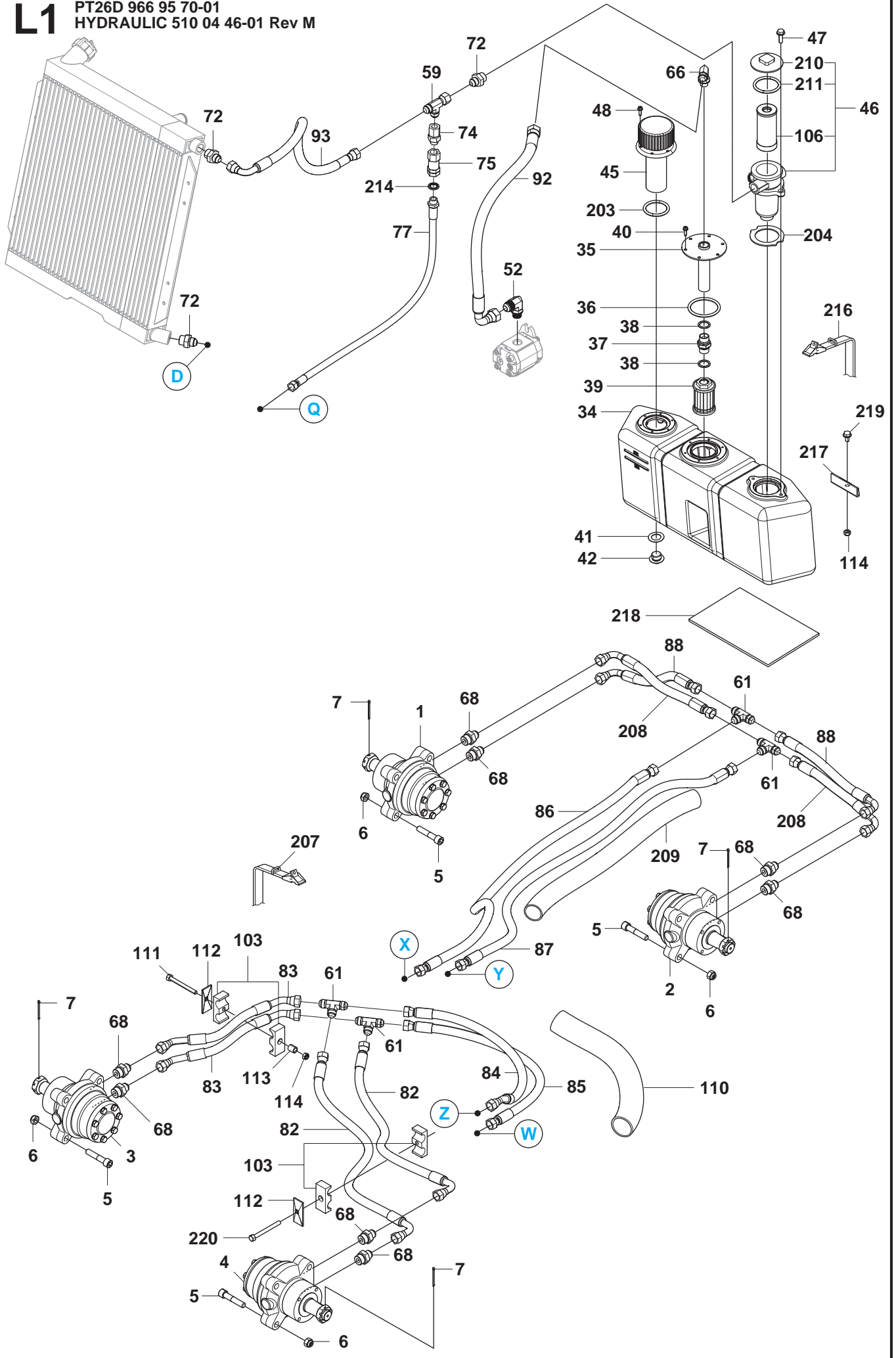

L2

PT26D 966 95 70-01
HYDRAULIC 510 04 46-01 Rev M

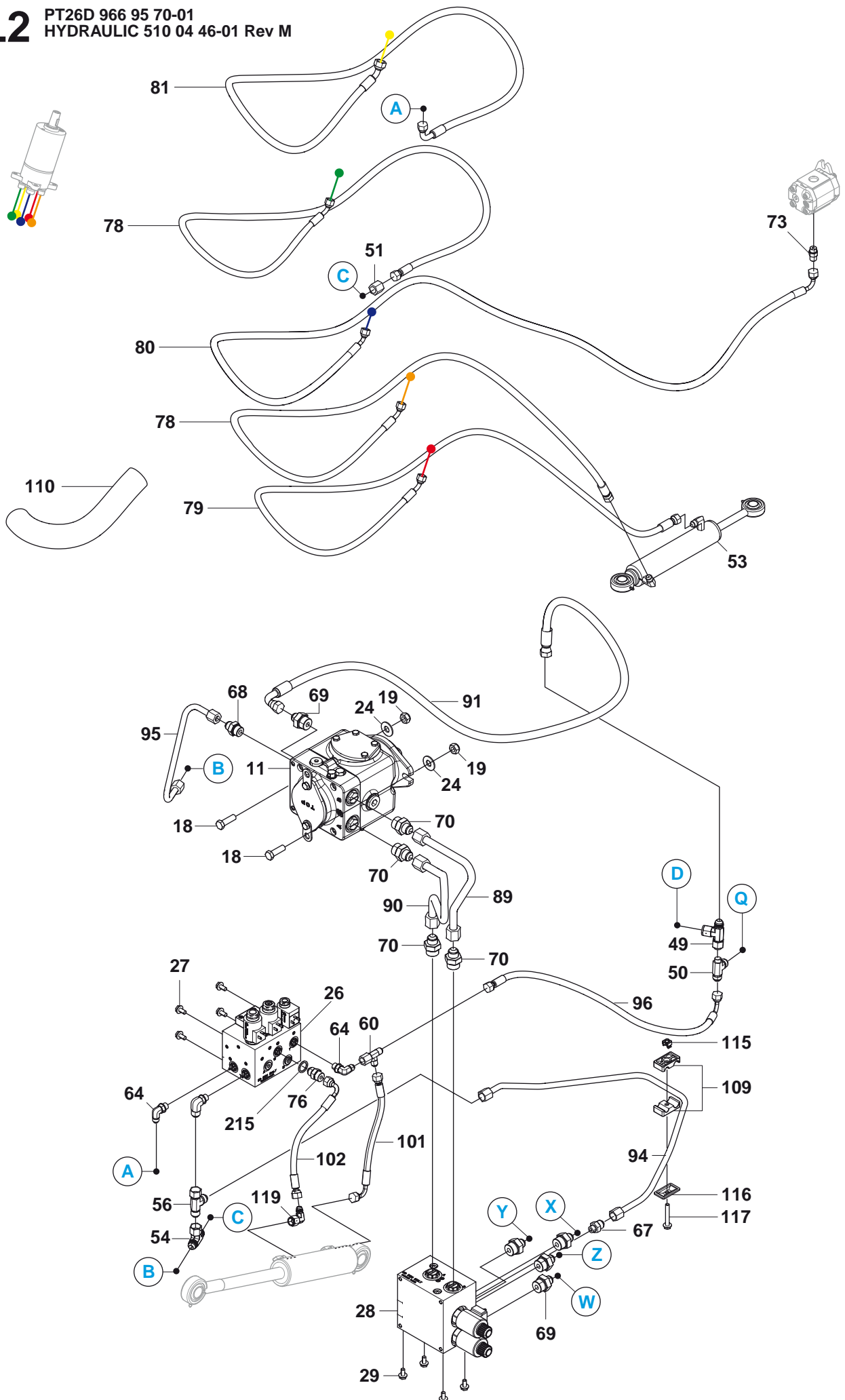

L HYDRAULIC

POS.	PART NO .	DESCRIPTION	QTY.
1	544 17 20-01	HJULMOTOR,125 CW	1
2	544 17 21-01	HJULMOTOR,125 CCW	1
3	544 17 22-01	HJULMOTOR,160 CW	1
4	544 17 23-01	HJULMOTOR,160 CCW	1
5	544 25 63-01	SKRUV IHSCM,12X60	16
6	732 25 22-01	MUTTER M12 LOC	16
7	721 61 87-01	SAXPINNE SP 3.2X40	4
11	510 02 04-01	HYDRAULPUMP	1
18	725 25 40-71	SKRUV,M6S12X40-8.8FZ	2
19	732 25 22-01	MUTTER M12 LOC	2
24	535 42 92-01	BRICKA	2
26	544 20 15-01	VENTILBLOCK,LIFT LOW	1
27	506 57 01-03	SKRUV EHHFM,8X16	4
28	544 20 14-01	VENTILBLOCK,TRANSMIS	1
29	506 57 01-03	SKRUV EHHFM,8X16	4
34	516 03 96-01	HYDRALIC TANK	1
35	522 03 34-01	PIPE ASSY.	1
36	544 04 65-05	GASKET	1
37	544 00 97-01	PIPE FITTING	1
38	544 01 00-01	GASKET	2
39	544 00 19-01	FILTER	1
40	535 41 56-19	FLÄNSSKRUV ST4.8x19	6
41	522 47 13-01	GASKET	1
42	522 47 12-01	SCREW	1
45	544 17 64-01	TANKLOCK	1
46	544 17 65-01	FILTERHÅLLARE	1
47	506 57 01-03	SKRUV EHHFM,8x16	3
48	535 41 56-19	LÅSMUTTER, M5	6
49	535 42 68-02	RÖRKOPPLING,JIC-JIC-JIC T	1
50	544 34 73-01	RÖRKOPPLING,JIC-JIC-JIC L	1
51	510 04 30-01	RÖRKOPPLING	1
52	535 42 66-07	RÖRKOPPLING	1
53	544 17 62-01	HYDRAULCYLINDER	1
54	522 73 33-01	RÖRKOPPLING	1
56	544 34 73-01	RÖRKOPPLING,JIC-UNF	1
59	544 34 73-01	RÖRKOPPLING,JIC-JIC-	3
60	544 34 73-02	RÖRKOPPLING,JIC-JIC-	2
61	544 01 56-01	RÖRKOPPLING,JIC T 3/	5
64	535 42 66-01	RÖRKOPPLING,JIC-UNF	3
66	535 43 73-03	RÖRKOPPLING,JIC-BSPP	1
67	535 42 65-02	PIPE FITTING	1
68	535 42 65-04	RÖRKOPPLING,JIC-UNF	10
69	535 42 65-05	RÖRKOPPLING,JIC-UNF	4
70	535 42 65-06	RÖRKOPPLING,JIC-UNF	2
72	535 42 68-02	RÖRKOPPLING,JIC-BSPP	2
73	535 42 65-03	RÖRKOPPLING,JIC-BSPP	1
74	544 01 57-01	RÖRKOPPLING,JIC-BSPP	1
75	544 01 54-03	CHECK VALVE,2BAR	1

76	535 43 71-02	RÖRKOPPLING,JIC-BSPP	1
77	544 38 44-02	HYDRAULSLANG,3/8"	1
78	544 30 58-01	HYDRAULSLANG,1/4" 10	2
79	544 30 58-03	HYDRAULSLANG	1
80	544 36 71-02	HYDRAULSLANG	1
81	544 36 71-01	HYDRAULSLANG,3/8"	1
82	544 30 54-03	HYDRAULSLANG,1/2" 27	2
83	544 40 39-01	HYDRAULSLANG,1/2"	2
84	544 30 54-03	HYDRAULSLANG	1
85	544 93 36-05	HYDRAULSLANG	1
86	544 93 36-03	HYDRAULSLANG,1/2"	1
87	544 93 36-05	HYDRAULSLANG,1/2"	1
88	544 30 55-08	HYDRAULSLANG	2
89	506 48 85-01	HYDRAULSLANG,5/8" 27	1
90	506 48 86-01	HYDRAULSLANG,5/8" 27	1
91	544 30 55-10	HYDRAULSLANG,3/8	2
92	544 38 34-01	HYDRAULSLANG,5/8"	1
93	544 30 55-07	HYDRAULSLANG	1
94	506 48 84-01	HYDRAULSLANG	1
95	506 48 83-01	HYDRAULSLANG,3/8"	1
96	544 36 69-02	HYDRAULSLANG,3/8"	1
101	544 35 72-02	HYDRAULSLANG	1
102	544 35 73-02	HYDRAULSLANG	1
103	544 37 33-01	RÖRHÅLLARE,ASSY Ø20X	2
106	544 42 72-01	FILTER, HYDRAULIC	1
109	522 62 42-01	PIPE CLAMP	1
110	505 45 38-01	HOSE GUARD	2
111	725 24 67-51	SCREW	1
112	544 37 38-01	COVER PLATE	2
113	504 61 61-01	TUBE	1
114	732 21 18-01	MUTTER	2
115	544 81 17-01	CAGE NUT, M8	1
116	544 37 38-01	COVER PLATE	1
117	506 57 01-03	SKRUV M6S, 8x80 8.8	1
119	544 02 67-02	RÖRKOPPLING	1
203	544 04 65-03	PACKNING,HYDRAULIC T	1
204	522 49 45-01	PACKNING,HYDRAULIC T	1
206	725 24 62-51	SKRUV M6S 8X55 FZ	1
207	506 83 68-03	BATTERIREM	1
208	544 30 55-09	HYDRAULSLANG	2
209	544 02 66-04	SLANGSKYDD	1
210	544 17 65-01	LOCK, HYDRUALIC	1
211	544 04 65-03	PACKNING,HYDRAULIC T	1
214	535 43 72-03	GUMMISTÅLBRICKA,G 3/	1
215	544 04 65-02	O-RING,12X2 NITRIL	1
216	506 83 68-04	BATTERI BELT	2
217	525 39 15-01	BRACKET, HYDRAULIC T	2
218	535 44 11-01	BATTERI MAT.	2
219	506 57 01-04	SCREW EHHFM 8x20	2
220	725 24 62-51	SCREW M8x55	1



6



7



8

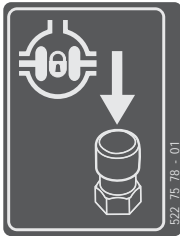

11

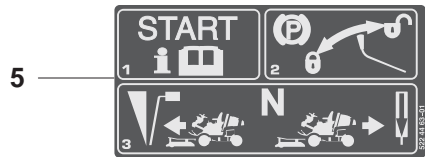

QUICKMAINTENANCE GUIDE FOR PT26D

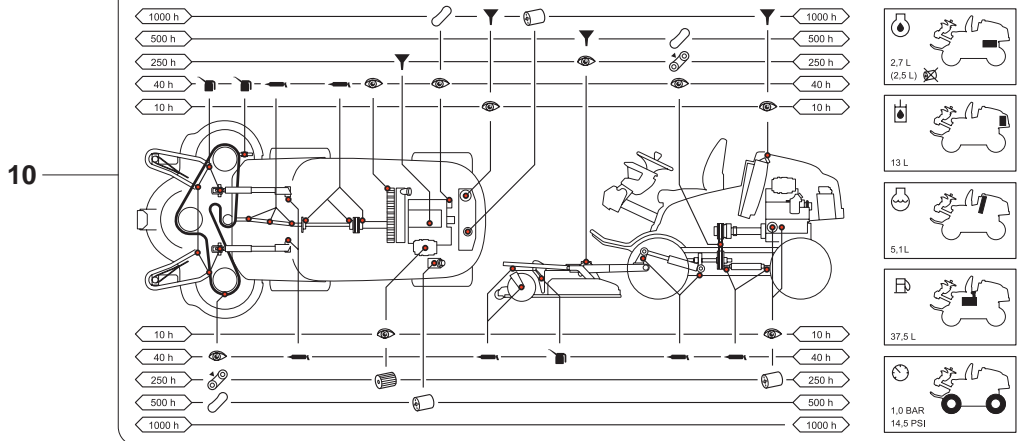

M DECALS

POS.	PART NO .	DESCRIPTION	QTY.
1	544 39 11-01	DEKAL,HUSQVARNA	2
2	544 39 12-01	DEKAL,PT26D	1
3	544 39 13-01	DEKAL,PT26D COMMERC	2
4	544 39 14-01	VARNINGSDEKAL,DANGER	2
5	522 44 63-01	DEKAL,START INFO	1
6	544 39 16-01	VARNINGSDEKAL,PROHIB	1
7	535 50 51-01	DEKAL,4X4	1
8	505 21 77-04	STANDARDDEKAL,104 dB	1
10	504 10 78-02	DEKAL,QUICK MAINTENA	1
11	522 75 78-01	DEKAL, DIFFERENTIAL P.	1

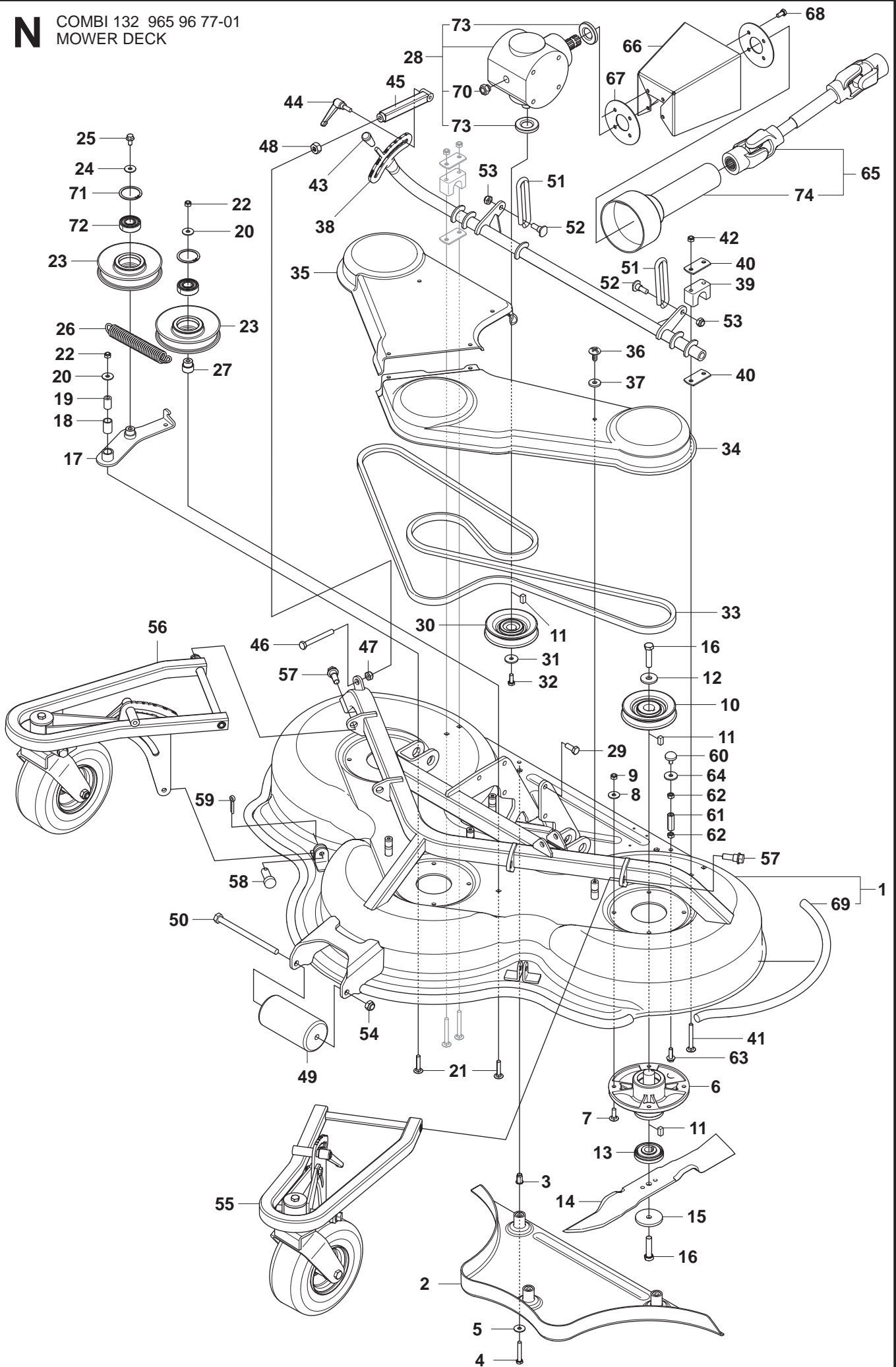
NCOMBI 132 965 96 77-01
MOWER DECK

N COMBI 132

POS.	PART NO .	DESCRIPTION	QTY.
1	544 16 25-02	KLIPPKÅPA KPL,C132	1
2	544 16 62-02	PLUGG KPL,C132	1
3	506 91 62-03	BLINDNITMUTTER,M8X19	3
4	725 24 61-51	SKRUV M6S 8X50 FZ	3
5	734 11 64-01	BRICKA,BRB 8.4X17	3
6	535 42 86-02	KNIVLAGRING KPL,OUTE	3
7	535 42 38-01	SKRUV,MVBF M8X25 GK	12
8	734 11 64-01	BRICKA,BRB 8.4X17	12
9	732 21 18-01	LÅSMUTTER,M8-8	12
10	544 25 56-01	REMSKIVA,SPB DP118 C	3
11	506 53 35-01	PLATTKIL,6X6X14	7
12	535 42 92-01	BRICKA	3
13	535 50 42-01	KNIVFÄSTE,XP	3
14	544 17 57-01	KNIV,C132	3
15	506 79 23-02	KNIVBRICKA	3
16	725 25 42-51	SKRUV EHHM,12X50 8.8	6
17	544 17 55-01	REMSPÄNNARE,CUTTING	1
18	506 98 61-03	BUSSNING	1
19	506 99 20-01	RÖR,LAGRING	1
20	734 11 64-41	BRICKA SRKB 8.4/25X2	2
21	727 64 59-51	SKRUV RSQM,8X40 8.8	2
22	732 21 18-01	LÅSMUTTER,M8-8	2
23	523 11 62-01	REMSPÄNNARHJUL KPL,A	2
24	734 11 64-41	BRICKA SRKB 8.4/25X2	1
25	725 24 49-61	SKRUV,M6SF 8X16 TAPT	1
26	544 21 81-05	DRAGFJÄDER,L=122	1
27	535 48 48-01	BUSSNING	1
28	544 18 34-01	VINKELVÄXEL	1
29	725 24 93-71	SKRUV M6S 10x25 FZ	5
30	504 87 74-01	REMSKIVA,SPB DP118	1
31	544 22 16-01	BRICKA,8.4X29X3	1
32	725 24 51-71	SKRUV M6S 8x20 FZ	1
33	504 87 73-01	REM,C132	1
34	544 18 45-01	REMKÅPA,C132 L	1
35	544 18 46-01	REMKÅPA,C132 R	1
36	506 98 26-01	SKRUV	5
37	506 55 97-01	GUMMIBRICKA	5
38	544 17 52-01	TVÄRSTAG	1
39	504 19 03-01	LAGERÖVERFALL,Ø25	2
40	506 81 38-01	FÖRSTÄRKNINGSPLÅT	4
41	535 42 38-02	SKRUV,MVBF M8X55 GK	4
42	732 21 18-01	LÅSMUTTER,M8-8	4
43	535 43 82-01	KNOPP	1
44	544 19 68-01	VRED,M 8	1
45	544 20 10-01	PARALLELLSTÅNG,C 132	1
46	725 25 09-71	SCREW	1
47	732 21 20-01	MUTTER,M10 LOC	1
48	731 23 20-51	MUTTER M10 FZ	1
49	544 18 54-01	RULLE	1
50	544 22 10-01	SKRUV EHHM,M12X180	1
51	544 18 50-01	LÄNK	2
52	544 21 43-01	SKRUV,LINK	2
53	732 21 20-51	MUTTER M10-LOCK	2
54	732 25 22-01	MUTTER M12 LOC	1
55	544 17 32-01	HJULUPPHÄNGNING,LEFT	1
56	544 17 32-02	HJULUPPHÄNGNING,RIGH	1
57	506 89 58-01	ANSATSSKRUV	4
58	721 84 56-01	BULT,10X25 FZB	2
59	721 61 83-01	SAXSPRINT 3.2x25	2

60	501 97 66-01	VIBRATIONISOLATOR	2
61	544 31 76-01	DISTANSHYLSA,SEAT	2
62	731 23 18-01	MUTTER M6M8 FZ	4
63	506 57 01-04	SKRUV EHHFM,8X20	2
64	734 11 64-41	BRICKA SRKB 8.4/25X2	2
65	525 57 12-01	SHAFT ASSY	1
66	522 75 00-01	PROTECTION	1
67	522 75 01-01	ATTACHMENT PLATE	2
68	506 57 01-04	SKRUV M8X20	4
69	522 52 35-01	REINFORCEMENT	2
70	525 24 97-01	WINDOW	1
71	735 31 40-10	CIRCLIP	2
72	738 22 04-19	BALL BEARING	2
73	525 24 98-01	GASKET	1
74	522 75 02-01	SAFETY GUARD	1

P

COMBI 155 965 96 78-01
MOWER DECK 544 16 20-02 R

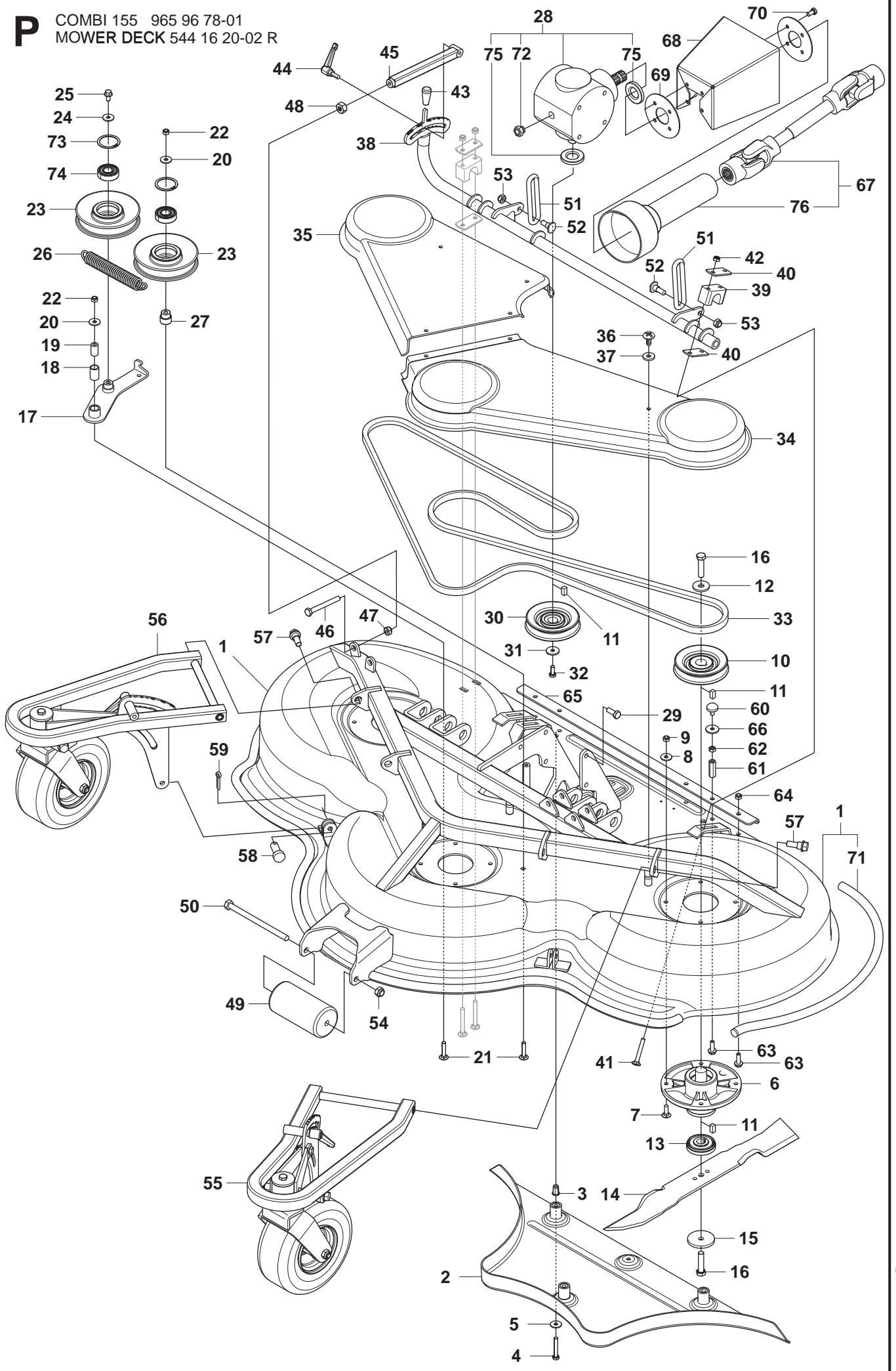

P COMBI 155

POS.	PART NO.	DESCRIPTION	QTY.
1	544 16 29-02	KLIPPKÅPA KPL,C155	1
2	544 16 64-02	PLUGG KPL,C155	1
3	506 91 62-03	BLINDNITMUTTER,M8X19	3
4	725 24 61-51	SKRUV M6S 8X50 FZ	3
5	734 11 64-01	BRICKA,BRB 8.4X17	3
6	535 42 86-02	KNIVLAGRING KPL,OUTE	3
7	535 42 38-01	SKRUV,MVBF M8X25 GK	12
8	734 11 64-01	BRICKA,BRB 8.4X17	12
9	732 21 18-01	LÅSMUTTER,M8-8	12
10	544 25 56-01	REMSKIVA,SPB DP118 C	3
11	506 53 35-01	PLATTKIL,6X6X14	7
12	535 42 92-01	BRICKA	3
13	535 50 42-01	KNIVFÄSTE,XP	3
14	544 17 58-01	KNIV,C155	3
15	506 79 23-02	KNIVBRICKA	3
16	725 25 42-51	SKRUV EHHM,12X50 8.8	6
17	544 17 55-01	REMSPÄNNARE,CUTTING	1
18	506 98 61-03	BUSSNING	1
19	506 99 20-01	RÖR,LAGRING	1
20	734 11 64-41	BRICKA SRKB 8.4/25X2	2
21	727 64 59-51	SKRUV RSQM,8X40 8.8	2
22	732 21 18-01	LÅSMUTTER,M8-8	2
23	523 11 62-01	REMSPÄNNARHJUL KPL,A	2
24	734 11 64-41	BRICKA SRKB 8.4/25X2	1
25	725 24 49-61	SKRUV,M6SF 8X16 TAPT	1
26	544 21 81-05	DRAGFJÄDER,L=122	1
27	535 48 48-01	BUSSNING	1
28	544 18 34-01	VINKELVÄXEL	1
29	725 24 93-71	SKRUV M6S 10x25 FZ	5
30	544 18 40-01	REMSKIVA,SPB DP106	1
31	544 22 16-01	BRICKA,8.4X29X3	1
32	725 24 51-71	SKRUV M6S 8x20 FZ	1
33	544 18 36-01	REM,C155	1
34	544 18 47-01	REMKÅPA,C155 L	1
35	544 18 48-01	REMKÅPA,C155 R	1
36	506 98 26-01	SKRUV	5
37	506 55 97-01	GUMMIBRICKA	5
38	544 17 52-01	TVÄRSTAG	1
39	504 19 03-01	LAGERÖVERFALL,Ø25	3
40	506 81 38-01	FÖRSTÄRKNINGSPLÅT	5
41	535 42 38-02	SKRUV,MVBF M8X55 GK	6
42	732 21 18-01	LÅSMUTTER,M8-8	6
43	535 43 82-01	KNOPP	1
44	544 19 68-01	VRED,M 8	1
45	544 20 11-01	PARALLELLSTÅNG,C 155	1
46	725 25 09-71	SCREW	1
47	732 21 20-01	MUTTER,M10 LOC	1
48	731 23 20-51	MUTTER M10 FZ	1
49	544 18 54-01	RULLE	1

50	544 22 10-01	SKRUV EHHM,M12X180	1
51	544 18 50-01	LÄNK	2
52	544 21 43-01	SKRUV,LINK	2
53	732 21 20-51	MUTTER M10-LOCK	2
54	732 25 22-01	MUTTER M12 LOC	1
55	544 17 32-01	HJULUPPHÄNGNING,LEFT	1
56	544 17 32-02	HJULUPPHÄNGNING,RIGH	1
57	506 89 58-01	ANSATSSKRUV	4
58	721 84 56-01	BULT,10X25 FZB	2
59	721 61 83-01	SAXSPRINT 3.2x25	2
60	501 97 66-01	VIBRATIONISOLATOR	2
61	544 31 76-01	DISTANSHYLSA,SEAT	2
62	731 23 18-01	MUTTER M6M8 FZ	2
63	506 57 01-04	SKRUV EHHFM,8X20	5
64	732 21 18-01	LÅSMUTTER,M8-8	3
65	501 97 67-01	FÖRSTÄRKNINGSPLÅT,DE	1
66	734 11 64-41	BRICKA SRKB 8.4/25X2	2
67	525 57 12-01	SHAFT ASSY	1
68	522 75 00-01	PROTECTION	1
69	522 75 01-01	ATTACHMENT PLATE	2
70	506 57 01-04	SKRUV M8	4
71	522 52 36-01	REINFORCEMENT	2
72	525 24 97-01	WINDOW	1
73	735 31 40-10	CIRCLIP	2
74	738 22 04-19	BALL BEARING	2
75	525 24 98-01	GASKET	1
76	522 75 02-01	SAFETY GUARD	1

Q COMBI 132
MOWER DECK
COMBI 155
MOWER DECK

56

55

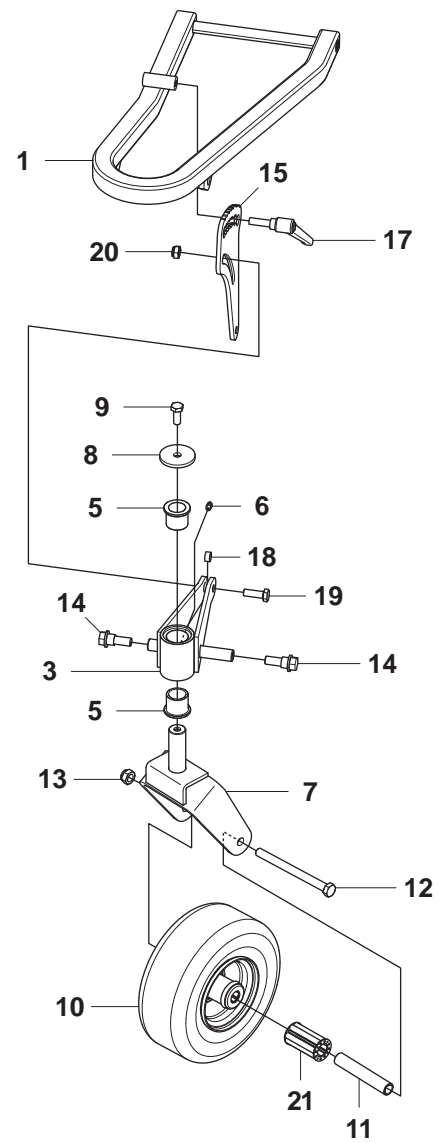
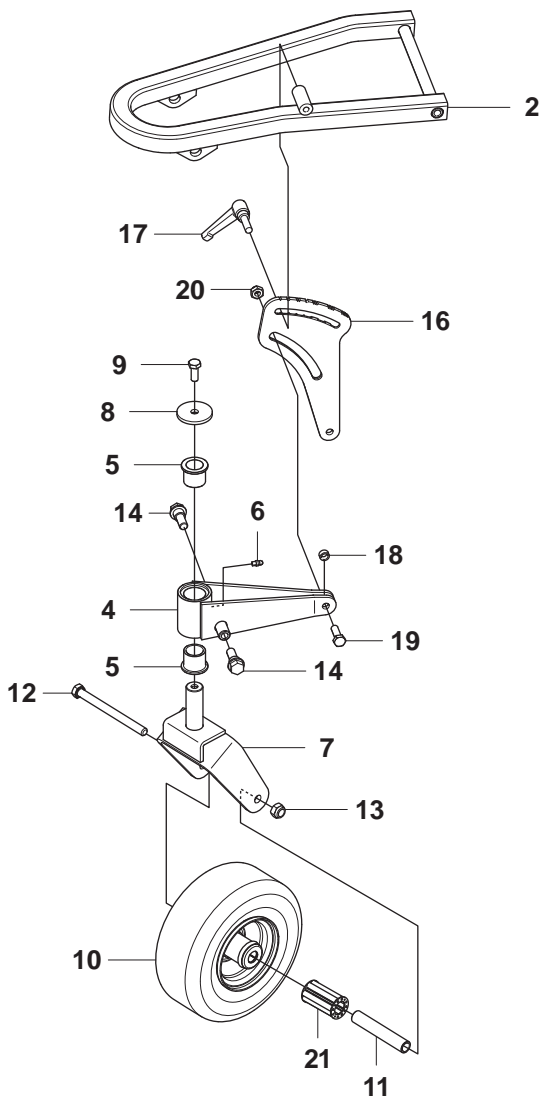

Q SUPPORT WHEELS

POS.	PART NO .	DESCRIPTION	QTY.	QTY.
55	544 17 32-01	HJULUPPHÄNGNING,LEFT	X	
56	544 17 32-02	HJULUPPHÄNGNING,RIGH		X
1	544 17 35-01	BÄRARM,LEFT	1	
2	544 17 35-02	BÄRARM,RIGHT		1
3	544 17 33-01	PIVOTHJULSFÄSTE,LEFT	1	
4	544 17 33-02	PIVOTHJULSFÄSTE,RIGH		1
5	544 17 41-02	LAGERBUSSNING,FLANGE	2	2
6	738 88 10-01	SMÖRJNIPPEL,AH M6 FZ	1	1
7	544 17 34-01	GAFFEL,PIVOT WHEEL	1	1
8	506 98 25-01	BRICKA	1	1
9	506 67 54-01	FLÄNSSKRUV	1	1
10	539 10 45-56	TIRE & WHEEL ASSEMBL	1	1
11	539 10 18-72	SPACER	1	1
12	725 25 59-51	SKRUV EHHM,12X140 FZ	1	1
13	732 21 22-01	MUTTER LOC-KING 12	1	1
14	506 89 58-01	ANSATSSKRUV	2	2
15	544 17 50-01	PLÄT,HEIGHT ADJUSTER	1	
16	544 17 50-02	PLÄT,HEIGHT ADJUSTER		1
17	544 19 18-01	VRED,M 10	1	1
18	544 20 02-01	HYLSA,PIVOT WHEEL SU	1	1
19	725 24 95-71	SKRUV M6S M10X30 FZ	1	1
20	732 21 20-51	MUTTER M10-LOCK	1	1
21	539 97 73-53	NÅLLAGER	1	1

R COMBI 132
MOWER DECK
COMBI 155
MOWER DECK

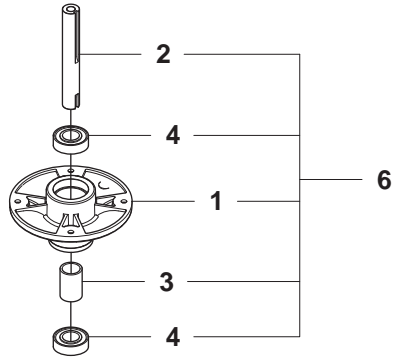

R SPINDLES

POS.	PART NO .	DESCRIPTION	QTY.
6	535 42 86-02	KNIVLAGRING KPL,OUTE	3
1	535 42 89-01	LAGERHUS	1
2	535 42 87-02	AXEL	1
3	535 42 88-01	DISTANS	1
4	738 22 05-19	KULLAGER 6205 2RS1	2

S

COMBI 132
DECALS MOWER DECK
COMBI 155
DECALS MOWER DECK

7



8



9

Combi 132

10

Combi 155



11

S DECALS

POS.	PART NO .	DESCRIPTION	QTY.	QTY.
	544 22 87-01	DEKALPLACERING,C132	X	
	544 22 87-02	DEKALPLACERING,C155		X
7	544 39 17-01	DEKAL,BELT DIAGRAM	1	1
8	506 92 90-01	DEKAL,CE	1	1
9	544 24 56-01	DEKAL,COMBI 132	1	
10	544 24 56-02	DEKAL,COMBI 155		1
11	574 51 00-01	DEKAL,WARNING	2	2