

YTH2042 TD

Spare parts

Ersatzteile

Pièces détachées

Reserve onderdelen

Repuestos

Reservdelar

**TRACTOR - - MODEL NO. YTH2042TD (96041005402), PRODUCT NO. 960 41 00-54
DECALS 27**

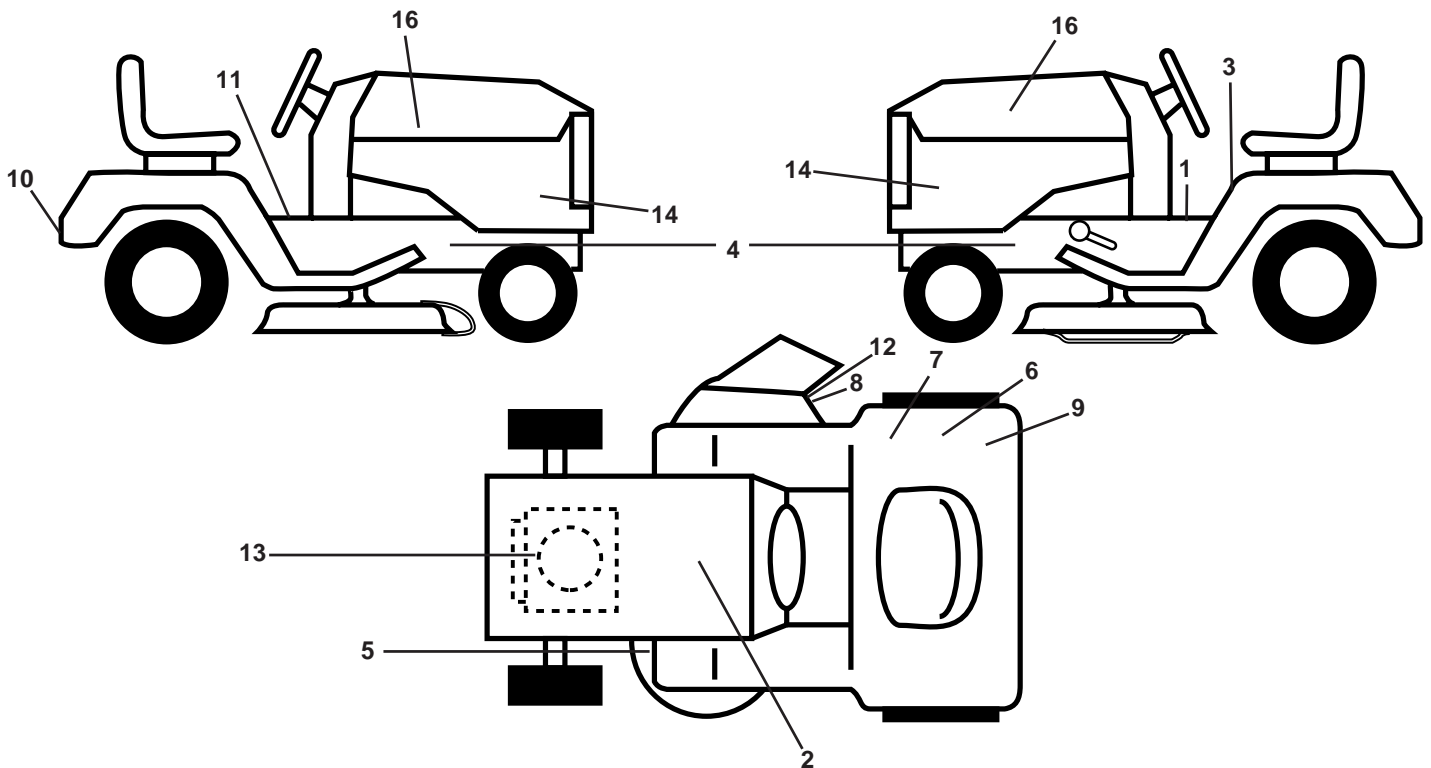

KEY NO.	PART NO.	DESCRIPTION
1	532 14 08-37	Decal, Saddle
2	532 14 50-05	Decal, Battery
3	532 40 03-89	Decal, Warn. Sym.
4	532 15 97-36	Decal, Chassis Hot
5	532 16 03-96	Decal, Caution
6	532 16 88-69	Decal, Tick Mark
7	532 12 44-33	Decal, DBA
8	532 19 63-57	Decal, Deflect
9	532 17 83-02	Decal, Oper. Cruise
10	532 16 25-98	Decal, Drawbar

KEY NO.	PART NO.	DESCRIPTION
11	532 15 97-37	Decal, Brake/Clutch
12	532 18 21-66	Decal, Cutfinger
13	532 19 68-41	Decal, Engine
14	532 42 39-87	Decal, Panel Side
16	532 42 20-12	Decal, Hood Logo
--	532 16 69-60	Decal, Bypass
--	532 40 17-71	Pad, Footrest, LH
--	532 40 37-73	Pad, Footrest, RH
--	532 42 41-92	Manual, Operator's (English)

WHEELS AND TIRES

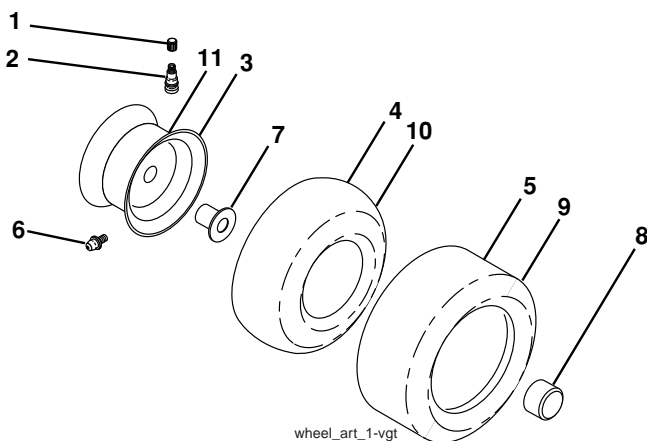

KEY NO.	PART NO.	DESCRIPTION
1	532 05 91-92	Cap, Valve, Tire
2	532 06 51-39	Stem, Valve
3	532 13 83-36	Rim Assembly, Front
4	532 05 99-04	Tube, Front (Service Item Only)
5	532 10 62-22	Tire, Front
6	532 12 49-57	Fitting, Grease (Front Wheel Only)
7	532 12 49-59	Bearing, Flange (Front Wheel Only)
8	532 17 50-39	Cap, Axle (Front Wheel Only)
9	532 12 20-82	Tire, Rear
10	532 12 49-26	Tube, Rear (Service Item Only)
11	532 13 83-37	Rim Assembly, Rear
--	532 14 43-34	Sealant, Tire (10 oz. Tube)

NOTE: All component dimensions given in U.S. inches
1 inch = 25.4 mm

TRACTOR - - MODEL NO. YTH2042TD (96041005402), PRODUCT NO. 960 41 00-54 SCHEMATIC 38

SCH12

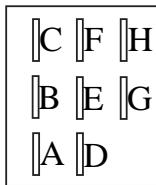
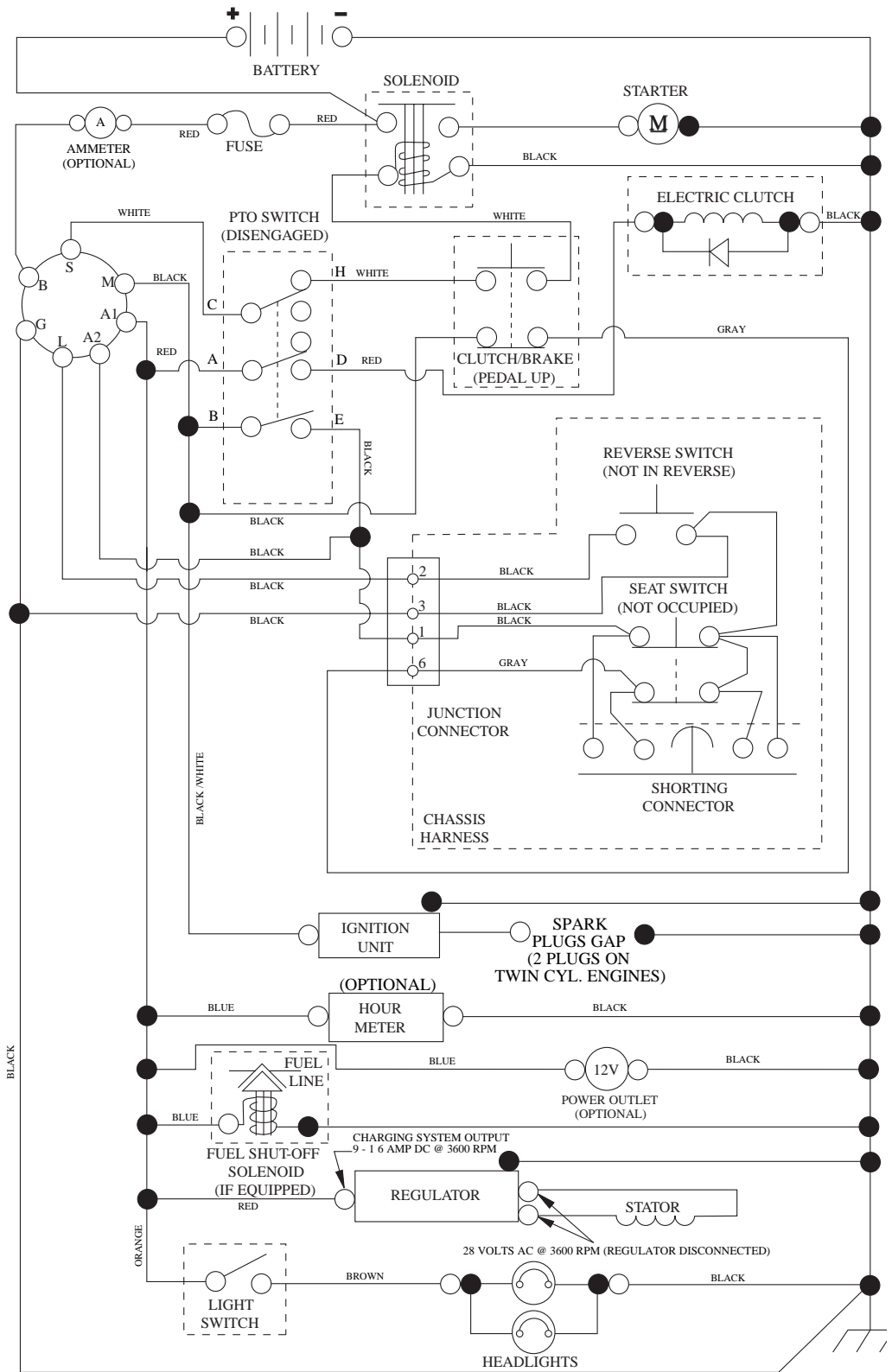

PTO SWITCH
(MATING SIDE)

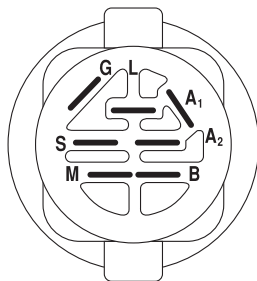

IGNITION SWITCH

POSITION	CIRCUIT	"MAKE"
OFF	M+G+A1	
RUN/OVERRIDE	B+A1	
RUN	B+A1	L+A2
START	B + S + A1	

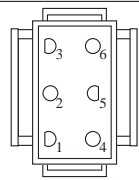

CHASSIS HARNESS
CONNECTOR
(MATING SIDE)

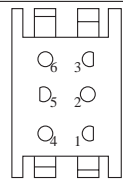

DASH HARNESS
CONNECTOR

WIRING INSULATED CLIPS
NOTE: IF WIRING INSULATED CLIPS WERE REMOVED FOR SERVICING OF UNIT, THEY SHOULD BE RE-INSTALLED TO PROPERLY SECURE YOUR WIRING.

NON-REMOVABLE
CONNECTIONS

REMOVABLE
CONNECTIONS

TRACTOR - - MODEL NO. YTH2042TD (96041005402), PRODUCT NO. 960 41 00-54
 ELECTRICAL **32**

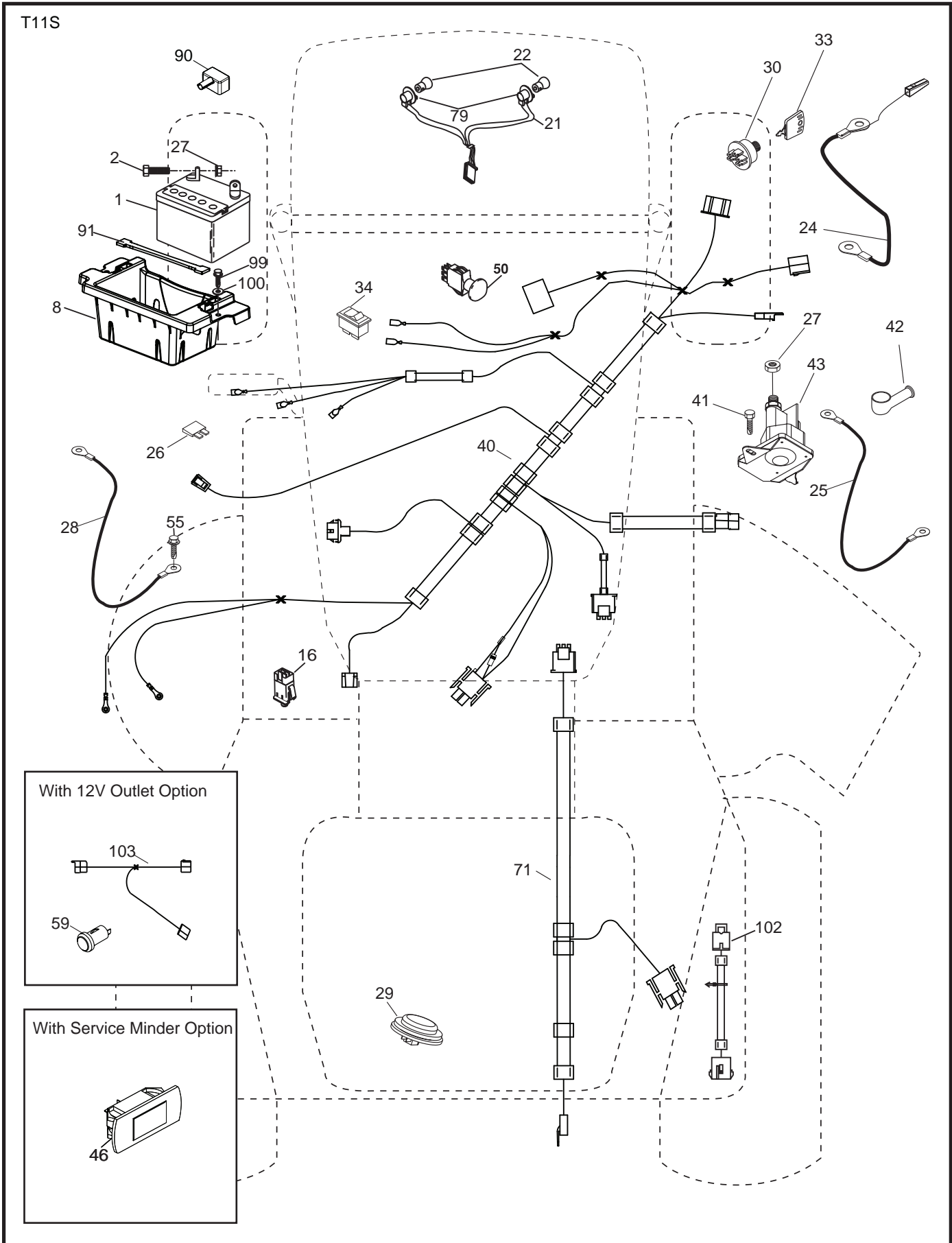

**TRACTOR - - MODEL NO. YTH2042TD (96041005402), PRODUCT NO. 960 41 00-54
ELECTRICAL 32**

KEY NO.	PART NO.	DESCRIPTION
1	532 16 34-65	Battery
2	874 76 04-12	Bolt Hex Hd 1/4-20 unc x 3/4
8	532 18 64-91	Battery Box
16	532 17 61-38	Switch Interlock
21	532 18 37-59	Harness Socket Light
22	532 00 41-52	Bulb, Light #1156
24	532 40 02-53	Cable Battery
25	532 41 28-95	Cable Starter
26	532 17 51-58	Fuse
27	873 51 04-00	Nut Keps Hex 1/4-20 unc
28	532 14 54-91	Cable Ground 21" Blk 6 Ga.
29	532 40 15-45	Switch Seat
30	532 19 33-50	Switch Ign
33	532 41 19-33	Key/Chain
34	532 11 07-12	Switch Light/Reset
40	532 40 11-04	Harness Ignition Dash
41	817 72 04-08	Screw Thd Cut 1/4-20 x 1/2
42	532 13 15-63	Cover Terminal Red
43	532 19 25-07	Solenoid
46	532 40 17-63	Gauge Hourmeter
50	532 17 46-51	Switch PTO
55	817 06 05-12	Screw Thdrol 5/16-18 x 3/4
59	532 40 03-03	Outlet 12 Volt
71	532 19 42-76	Harness Chassis
79	532 17 52-42	Socket Asm. Bulb
90	532 40 07-24	Cover Terminal Battery
91	532 19 02-70	Strap Battery
99	817 67 04-12	Screw Hexwsh Thdrol 1/4-20 x 3/4
100	819 09 14-16	Washer 9/32 x 7/8 x 16 Ga.
102	532 40 44-54	Harness Pigtail
103	532 40 79-62	Harness Pigtail 12v Outlet
105	532 40 75-68	Switch Reverse

NOTE: All component dimensions given in U.S. inches
1 inch = 25.4 mm

TRACTOR - - MODEL NO. YTH2042TD (96041005402), PRODUCT NO. 960 41 00-54
CHASSIS AND ENCLOSURES **39**

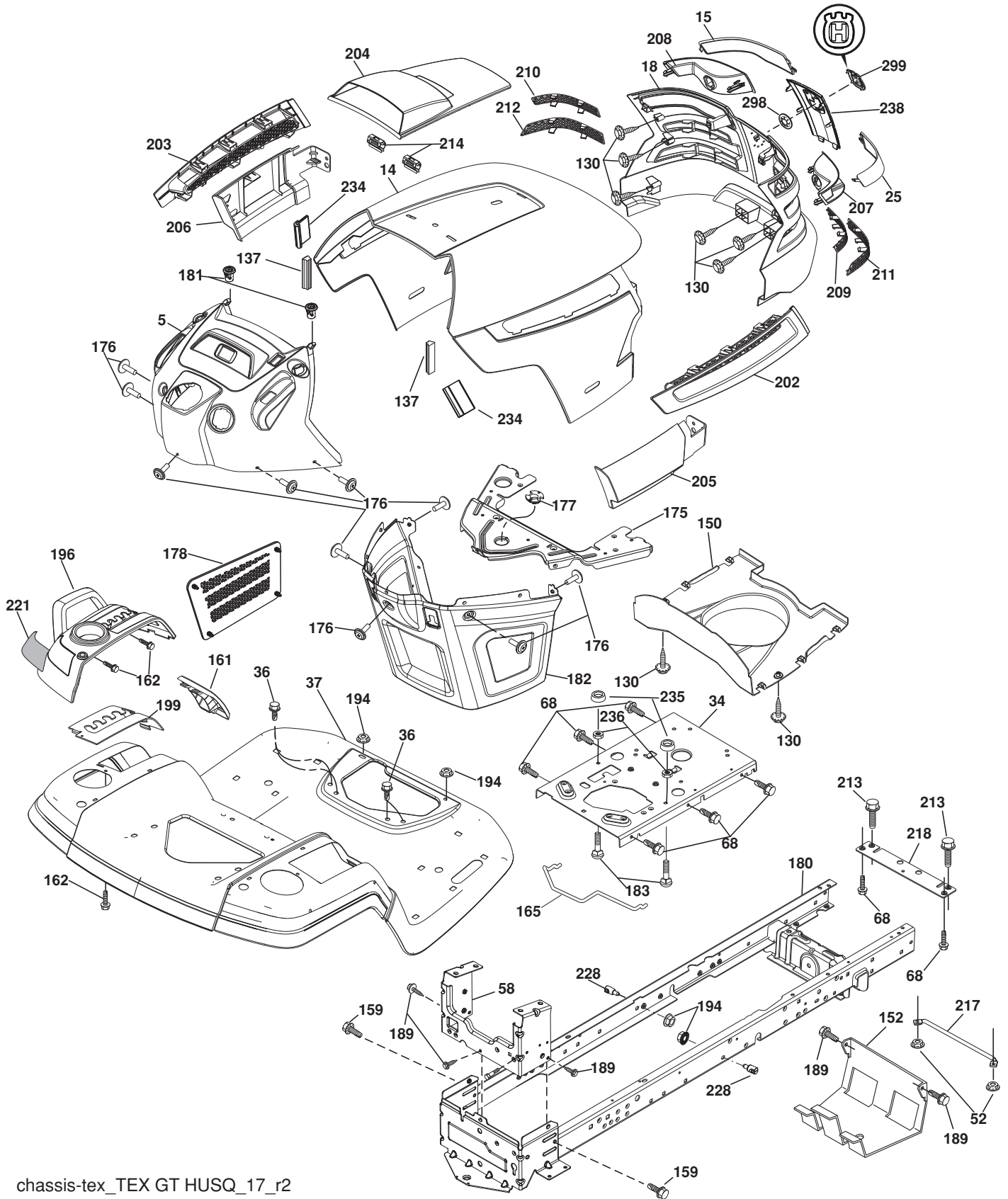

chassis-tex_TEX GT HUSQ_17_r2

**TRACTOR - - MODEL NO. YTH2042TD (96041005402), PRODUCT NO. 960 41 00-54
CHASSIS AND ENCLOSURES 39**

KEY NO.	PART NO.	DESCRIPTION
5	532 40 87-01	Dash
14	532 41 10-46	Hood
15	532 19 89-07	Lens LH
18	532 40 86-07	Grille Asm.
25	532 19 89-06	Lens RH
34	532 19 61-25	Plate Engine
36	817 06 05-12	Screw 5/16-18 x 3/4
37	532 40 18-25	Fender
52	873 68 05-00	Nut Lock 5/16-18
58	532 41 22-81	Drawbar Upper
68	817 49 05-08	Screw 5/16-18 x 1/2
130	532 41 63-58	Screw #10 x 0.750
137	532 40 75-90	Bumper Dash
150	532 19 85-12	Air Duct
152	532 19 95-35	Shield Browning
159	817 00 06-12	Screw 3/8-16 x 3/4
161	532 40 18-26	Window Fuel
162	532 14 24-32	Screw
165	532 19 68-26	Support Tank Rear
175	532 19 63-04	Crossmember
176	532 40 07-76	Screw 10-24 x 5/8
177	532 19 52-27	Bushing Steering
178	532 19 97-82	Cargo Net Asm.
180	532 41 50-64	Chassis
181	532 40 30-25	Bushing Mtg. Fender Crgo
182	532 40 68-59	Dash Lower
183	874 78 05-20	Bolt Fin Hex 5/16-18 unc x 1-1/4
189	817 00 05-12	Screw 5/16-18 x 3/4
194	873 90 05-00	Nut Lock Hex Flange 5/16-18

KEY NO.	PART NO.	DESCRIPTION
196	532 40 02-99	Console Asm. Deck Lift
199	532 19 82-59	Plate Deck Lift
202	532 40 30-48	Vent Side Hood RH
203	532 40 30-76	Vent Side Hood LH
204	532 41 66-13	Vent Top Hood
205	532 40 17-09	Skirt Hood Side RH
206	532 40 17-11	Skirt Hood Side LH
207	532 19 71-98	Bezel RH
208	532 19 71-99	Bezel LH
209	532 19 91-30	Insert Hex Top RH
210	532 19 91-31	Insert Hex Top LH
211	532 19 91-32	Insert Hex Bottom RH
212	532 19 91-33	Insert Hex Bottom LH
213	874 76 05-12	Bolt 5/16-18 unc x 3/4
214	532 19 91-45	Clip Retainer Tinner
217	532 40 91-67	Rod Pivot
218	532 19 63-95	X-Piece Hood Stop
221	532 19 89-09	Reflector LH
228	532 19 51-61	Stud Fastner
234	532 40 47-42	Bumper Hood
235	532 40 61-29	Spacer Fender
236	873 93 05-00	Nut Lock 5/16-18 unc
238	532 40 86-06	Trim
298	532 11 04-52	Nut Push
299	532 40 50-12	Logo

NOTE: All component dimensions given in U.S. inches
1 inch = 25.4 mm

TRACTOR - - MODEL NO. YTH2042TD (96041005402), PRODUCT NO. 960 41 00-54
DRIVE **40**

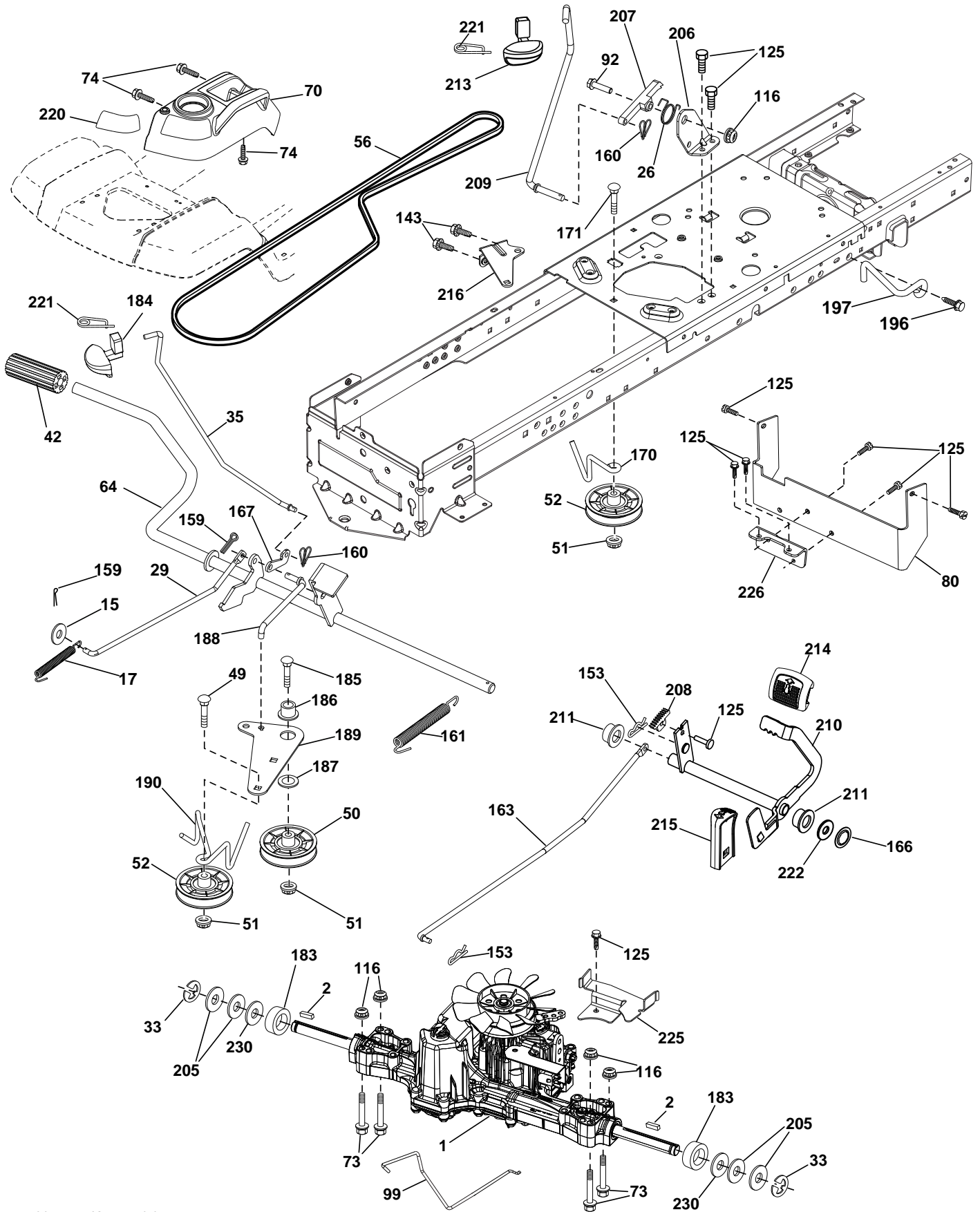

drive-tex_K46_pedal_13

**TRACTOR - - MODEL NO. YTH2042TD (96041005402), PRODUCT NO. 960 41 00-54
DRIVE **40****

KEY NO.	PART NO.	DESCRIPTION	KEY NO.	PART NO.	DESCRIPTION
1	-----	Transaxle, TUFFTORQ K46 CR	171	872 11 06-16	Bolt RDHD SQNK 3/8-16 unc x 2
2	532 12 35-83	Key 1/4 x 2.5	183	532 13 70-57	Spacer Split
15	819 13 13-16	Washer 13/32 x 13/16 x 16 Ga.	184	532 40 31-18	Handle Parking Brake
17	532 41 36-78	Spring, Brake	185	872 11 06-22	Bolt RDHD 3/8-16 x 2-3/4 Gr. 5
26	532 19 96-79	Spring Return Cruise	186	532 19 43-21	Spacer Retainer
29	532 40 38-06	Rod, Brake	187	819 13 32-10	Washer
33	812 00 00-01	Ring E	188	532 19 43-23	Link Clutch Ground Drive
35	532 19 95-91	Rod, Brake, Park	189	532 19 43-17	Bellcrank Ground Drive
42	532 12 48-72	Cover, Foot Pedal	190	532 19 43-18	Keeper Bellcrank Ground Drive
49	872 11 06-14	Bolt	196	817 00 06-16	Screw 3/8-16 x 1
50	532 19 43-27	Pulley Idler Flat	197	532 19 58-04	Link Clutch Anti-Rotation
51	873 90 06-00	Lock Nut 3/8-16	205	532 12 17-48	Washer
52	532 19 43-26	Idler V-Groove 910" Offset	206	532 19 78-67	Bracket Mount Latch Cruise
56	532 13 09-69	V-Belt, Drive	207	532 19 78-68	Latch Control Cruise
64	532 19 78-65	Shaft Asm. Pedal Brake Control	208	532 19 78-69	Gear Sector Control Cruise
70	532 40 05-30	Console Asm.	209	532 19 95-92	Rod Control Cruise
73	874 49 05-44	Bolt Hex 5/16-18 Gr. 5	210	532 19 78-60	Rocker Asm. Pedal Control
74	532 14 24-32	Screw 1/4 x 1/2	211	532 12 01-83	Bearing Nylon
80	532 41 00-24	Strap Torque	213	532 40 31-19	Knob Control Cruise
92	874 76 05-20	Bolt Fin Hex 5/16-18 unc x 1.25	214	532 42 12-63	Pedal Forward
99	532 41 57-42	Rod Spring Bypass	215	532 40 17-23	Pedal Reverse
116	873 90 05-00	Nut Lock Hex Flange 5/16-18	216	532 19 61-31	Bracket Pulley Idler
125	817 00 05-12	Screw 5/16-18 x 3/4	220	532 19 89-08	Reflector RH
143	817 49 05-08	Screw 5/16-18 x 1/2	221	532 40 31-87	Retainer Spring Clip Handle
153	532 12 47-88	Retainer Spring	222	879 21 20-10	Washer 21/32 x 1-1/4 x 10 Ga.
159	876 02 04-12	Pin Cotter 1/8 x 3/4	225	532 40 33-19	Keeper Belt Trans.
160	532 16 94-84	Retainer Clip	226	532 40 15-64	Bracket Mount Torque
161	532 10 57-09	Spring, Return, Clutch	230	532 18 89-67	Washer Hardened
163	532 40 10-34	Rod Pedal Control			
166	532 19 72-90	Nut Push .625			
167	532 40 52-57	Latch Brake Parking			
170	532 19 43-22	Keeper Belt Centerspan			

NOTE: All component dimensions given in U.S. inches
1 inch = 25.4 mm

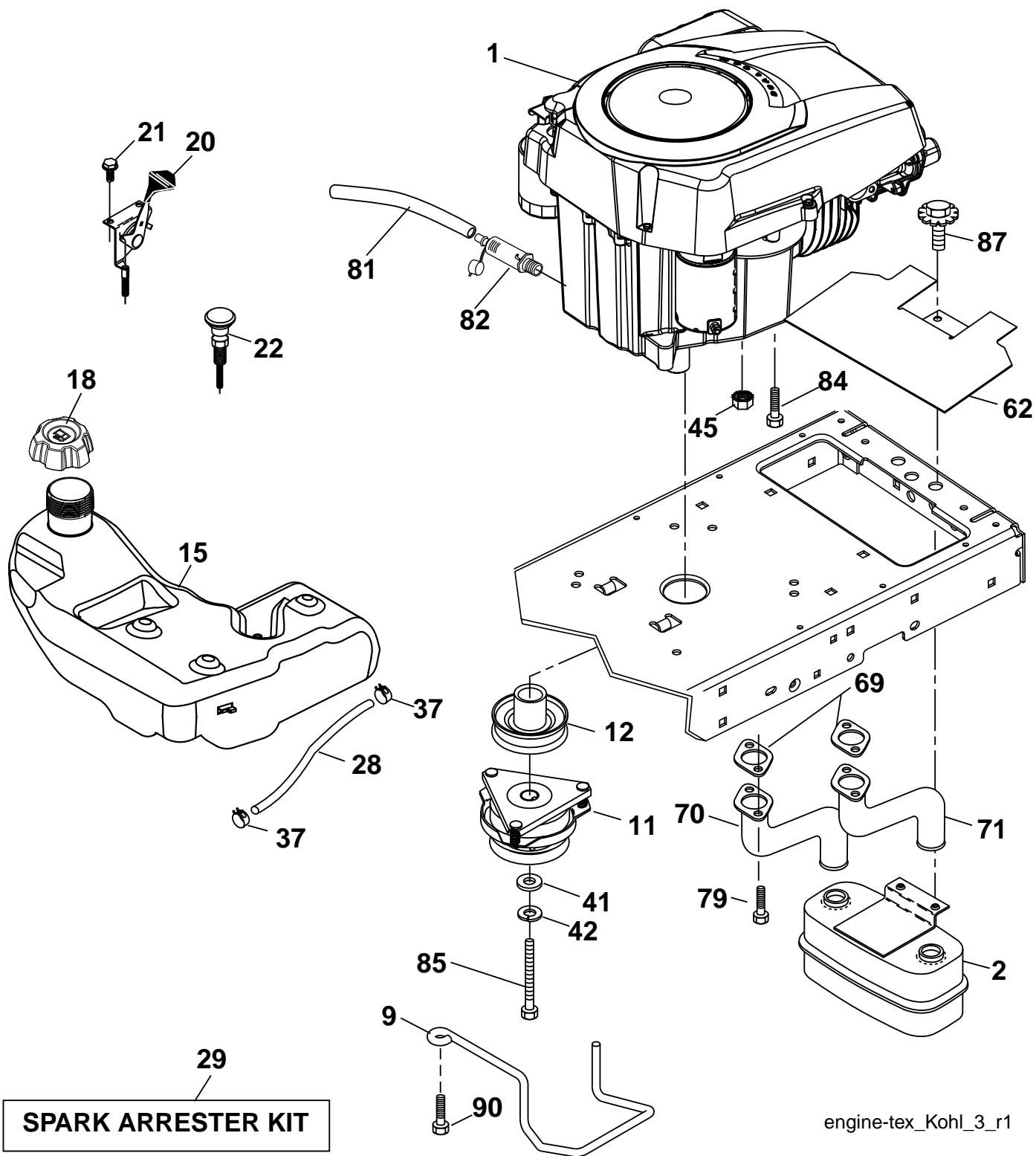

**TRACTOR - - MODEL NO. YTH2042TD (96041005402), PRODUCT NO. 960 41 00-54
ENGINE 24**

KEY NO.	PART NO.	DESCRIPTION
1	-----	Engine Kohl Model No. SV710
2	532 14 97-23	Muffler
9	532 19 43-20	Keeper Belt Engine
11	532 18 05-05	Clutch Electric
12	532 40 50-97	Pulley Engine
15	532 19 34-99	Tank Fuel 4.0
18	532 19 42-67	Cap Asm
20	532 18 29-37	Control Throttle
21	532 41 63-58	Screw #10 x 0.750
22	532 19 15-96	Control Choke
28	532 14 21-58	Fuel Line
29	532 13 71-80	Spark Arrester Kit
37	532 12 34-87	Clamp Hose
41	532 12 61-97	Washer 1-1/2 OD x 15/32 ID x .250
42	810 04 07-00	Washer Lock 7/16
45	873 51 04-00	Nut Keps Hex 1/4-20 unc
62	532 14 66-29	Shield Heat Muffler
69	532 18 60-54	Gasket
70	532 14 66-99	Tube Exhaust LH
71	532 14 67-00	Tube Exhaust RH
79	532 19 23-34	Screw Socket HD 5/16-18 x .75
81	532 14 84-56	Tube Drain Oil Easy
82	532 18 16-54	Plug Drain Oil
84	817 12 06-16	Screw 3/8-16 x 1
85	532 17 39-37	Bolt Hex 7/16-20 x 4.00 Gr. 5
87	532 17 18-77	Bolt 5/16-18 unc x 3/4 w/Sems
90	817 00 06-16	Screw 3/8-16 x 1

NOTE: All component dimensions given in U.S. inches
1 inch = 25.4 mm

TRACTOR - - MODEL NO. YTH2042TD (96041005402), PRODUCT NO. 960 41 00-54
STEERING ASSEMBLY **41**

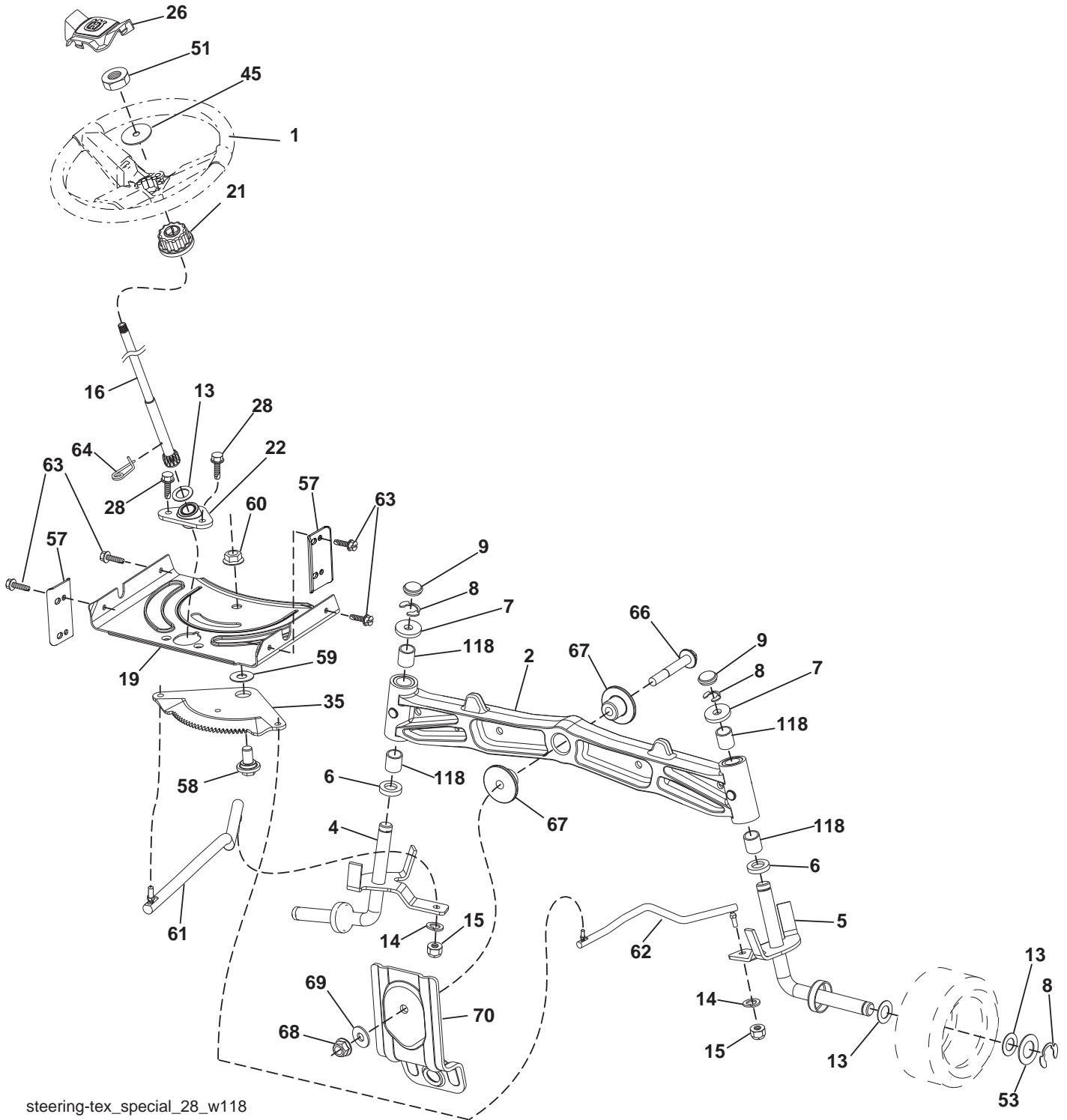

steering-tex_special_28_w118

**TRACTOR - - MODEL NO. YTH2042TD (96041005402), PRODUCT NO. 960 41 00-54
STEERING ASSEMBLY **41****

KEY NO.	PART NO.	DESCRIPTION
1	532 41 64-80	Wheel, Steering
2	532 41 35-91	Axle Asm., Front
4	532 40 30-87	Spindle Asm., LH
5	532 40 30-88	Spindle Asm., RH
6	532 12 49-31	Bearing, Race Thrust Harden
7	532 12 17-48	Washer 25/32 x 1-5/8 x 16 Ga.
8	812 00 00-29	Ring, Klip #T5304-75
9	532 12 12-32	Cap, Spindle
13	532 12 17-49	Washer 25/32 x 1-1/4 x 16 Ga.
14	810 04 06-00	Washer, Lock Hvy Hlcl Spr 3/8
15	873 54 06-00	Nut, Crown Lock 3/8-24 unf
16	532 19 47-46	Shaft Steering
19	532 19 47-29	Plate Steering
21	532 18 67-37	Adapter, Wheel Steering
22	532 19 48-45	Bushing, Strg. Blk
26	532 41 59-87	Insert, Wheel Steering
28	817 00 06-12	Screw 3/8-16 x 3/4
35	532 19 47-32	Gear, Sector Plate
45	819 18 38-12	Washer 9/16 x 2-3/8 x 12 Ga.
51	873 94 08-00	Nut Hex Jam Toplock 1/2-20 unf
53	532 18 89-67	Washer Hardened .793x1.637x.060
57	532 40 74-65	Bracket Upstop
58	532 19 47-47	Bolt Shoulder Sector Pivot CFM
59	532 19 47-48	Washer Thrust Sector Steering
60	873 97 10-00	Nut Flange Lock 5/8-11
61	532 19 47-40	Draglink, LH
62	532 19 47-41	Draglink, RH
63	817 00 05-12	Screw 5/16-18 x 3/4
64	532 19 98-49	Retainer Clip Spring Steering
66	871 02 07-48	Bolt Hex Fghd 7/16-14 x 3 Serr
67	532 19 47-37	Bushing PM Front Axle
68	873 90 07-00	Nut Lock Flange 7/16-14 Gr. 5
69	532 19 91-62	Washer 1.5 x .505 x .118
70	532 19 61-97	Bracket Deck Susp. Front
118	532 40 60-13	Bushing

NOTE: All component dimensions given in U.S. inches
1 inch = 25.4 mm

TRACTOR - - MODEL NO. YTH2042TD (96041005402), PRODUCT NO. 960 41 00-54
 MOWER DECK **44**

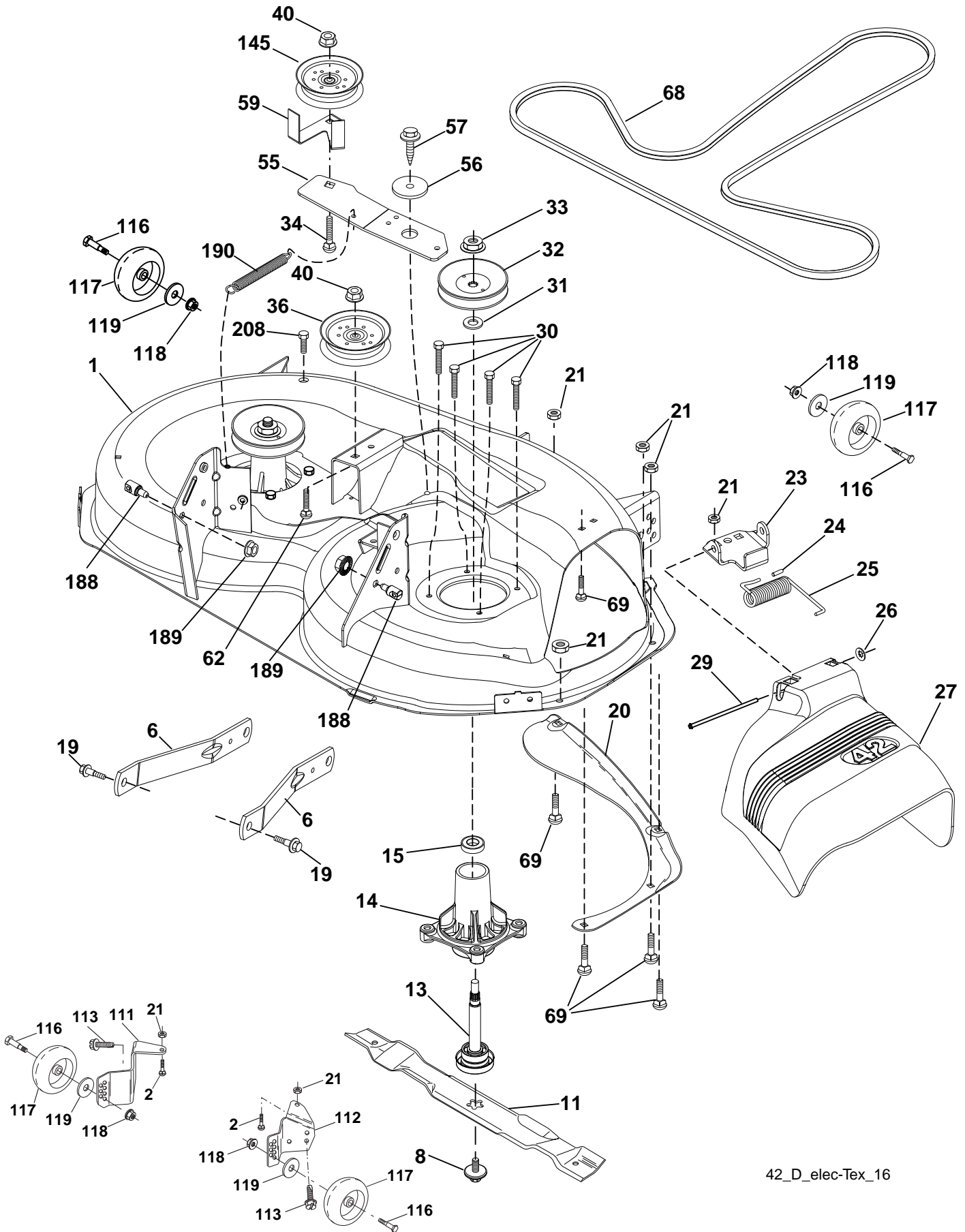

42_D_elec-Tex_16

**TRACTOR - - MODEL NO. YTH2042TD (96041005402), PRODUCT NO. 960 41 00-54
MOWER DECK 44**

KEY NO.	PART NO.	DESCRIPTION
1	532 40 29-99	Mower Housing
2	872 14 05-06	Bolt RDHD SQNK 5/16-18 unc x 3/4
6	532 19 51-86	Arm Suspension
8	532 19 30-03	Bolt/Washer Asm 7/16-20 unf
11	532 13 89-71	Blade, 42" Hi-Lift (For bagging or discharge)
13	532 19 28-72	Shaft Assembly, Mandrel
14	532 18 72-81	Housing, Mandrel
15	532 11 04-85	Bearing, Ball, Mandrel
19	532 19 65-39	Bolt, Shoulder
20	532 15 97-70	Baffle, Vortex
21	873 68 05-00	Nut, Crownlock 5/16-18 unc
23	532 19 25-57	Bracket, Deflector
24	532 10 53-04	Cap, Sleeve
25	532 19 70-26	Spring, Torsion, Deflector
26	532 11 04-52	Nut, Push
27	532 40 30-04	Shield, Deflector
29	532 13 14-91	Rod, Hinge
30	532 17 39-84	Screw Thdrol Rolling Wsh Hd
31	532 18 76-90	Washer, Spacer
32	532 15 35-35	Pulley, Mandrel
33	532 40 02-34	Nut, Toplock, Flanged
34	872 11 06-12	Bolt Carr Sh. 3/8-16 x 1-1/2 Gr. 5
36	532 19 73-79	Pulley, Idler, Primary
40	873 90 06-00	Nut, Lock Flg. 3/8-16 unc
55	532 19 72-49	Arm, Idler

KEY NO.	PART NO.	DESCRIPTION
56	532 19 90-92	Spacer, Retainer
57	817 00 06-16	Screw 3/8-16 x 1
59	532 14 10-43	Guard, Tuv Idler
62	872 11 06-16	Bolt RDHD SQNK 3/8-16 x 2
68	532 14 49-59	V-Belt
69	872 14 05-05	Bolt
111	532 40 47-84	Bracket Wheel Gauge LH 42"
112	532 40 47-85	Bracket Wheel Gauge RH 42"
113	817 00 05-10	Bolt 5/16-18 Hex WSHDLCKSERR
116	532 12 48-42	Bolt, Shoulder
117	532 18 86-06	Wheel, Gauge
118	873 93 06-00	Nut, Lock 3/8-16 unc
119	819 12 14-14	Washer 3/8 x 7/8 x 14 Ga.
145	532 19 31-97	Pulley Idler
188	532 19 51-61	Stud Fastener
189	873 90 05-00	Nut Lock Hex Flange
190	532 19 72-51	Spring Mower Drive
208	817 67 06-08	Screw THDROL 3/8-16 x 1/2
--	532 19 28-70	Mandrel Assembly (Includes housing, shaft assembly, and bearing only - pulley/nut/washer and blade bolt/washers not included)
--	532 40 12-28	Replacement Mower, Complete

NOTE: All component dimensions given in U.S. inches
1 inch = 25.4 mm

TRACTOR - - MODEL NO. YTH2042TD (96041005402), PRODUCT NO. 960 41 00-54
 MOWER LIFT **45**

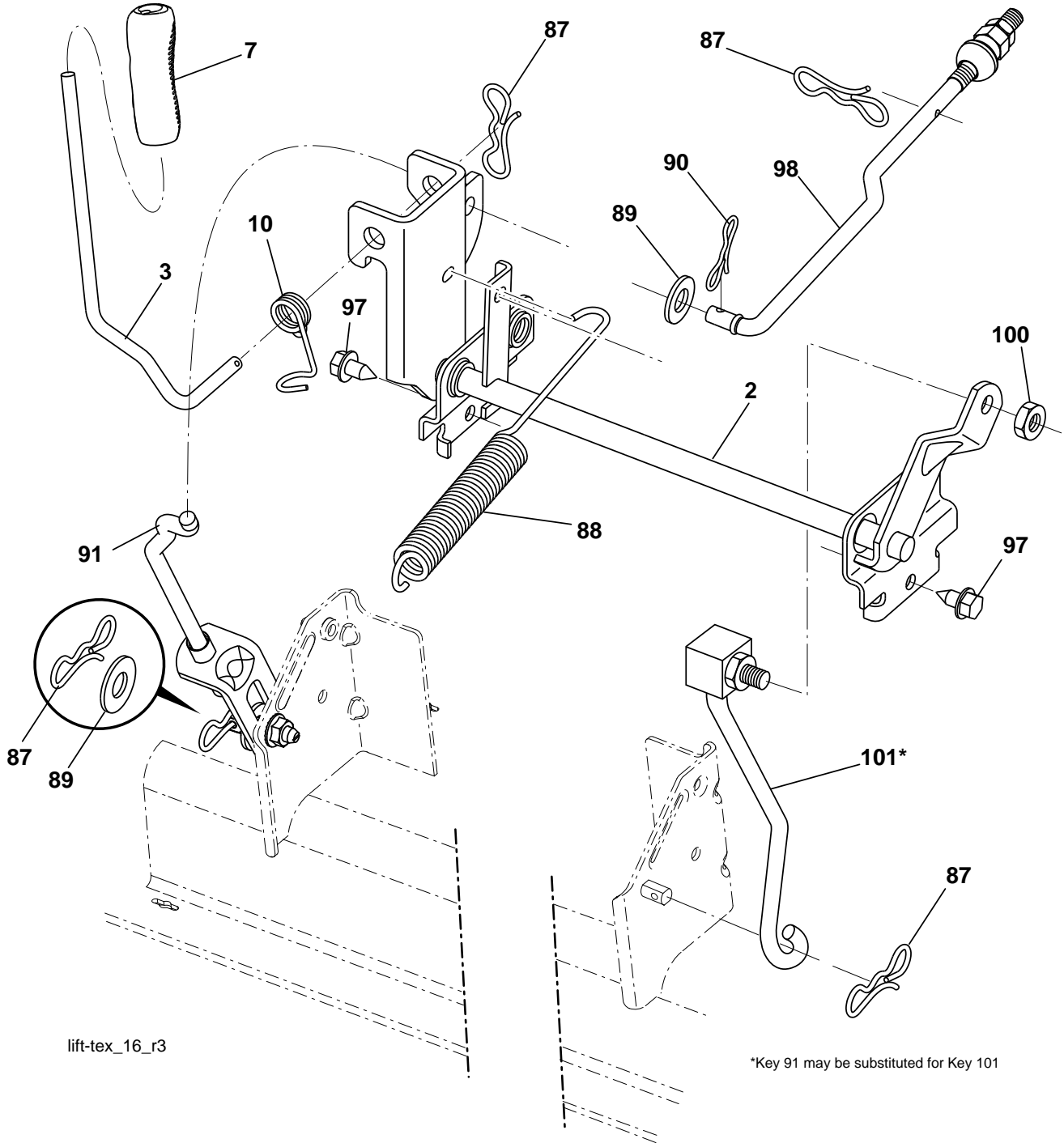

KEY NO.	PART NO.	DESCRIPTION
2	532 19 52-23	Shaft Asm., Lift
3	532 19 52-30	Lever Asm., Lift
7	532 41 15-55	Grip, Lever
10	532 19 63-14	Spring Torsion
87	532 19 42-09	Pin Cotter 7/16 Bow Tie Lock
88	532 41 07-10	Spring Lift Assist
89	819 19 19-12	Washer Clear Zinc
90	532 19 42-08	Pin Cotter 5/16 Bow Tie Lock
91	532 19 51-81	Link Lift Susp Mower Rear

KEY NO.	PART NO.	DESCRIPTION
97	817 00 06-12	Screw 3/8-16 x 3/4
98	532 19 52-70	Link Lift Susp. Front Mower
100	873 93 06-00	Nut Centerlock 3/8-16 unc
101	532 40 70-03	Link Asm. Lift FXD

NOTE: All component dimensions given in U.S. inches
 1 inch = 25.4 mm

**TRACTOR - - MODEL NO. YTH2042TD (96041005402), PRODUCT NO. 960 41 00-54
SEAT ASSEMBLY 42**

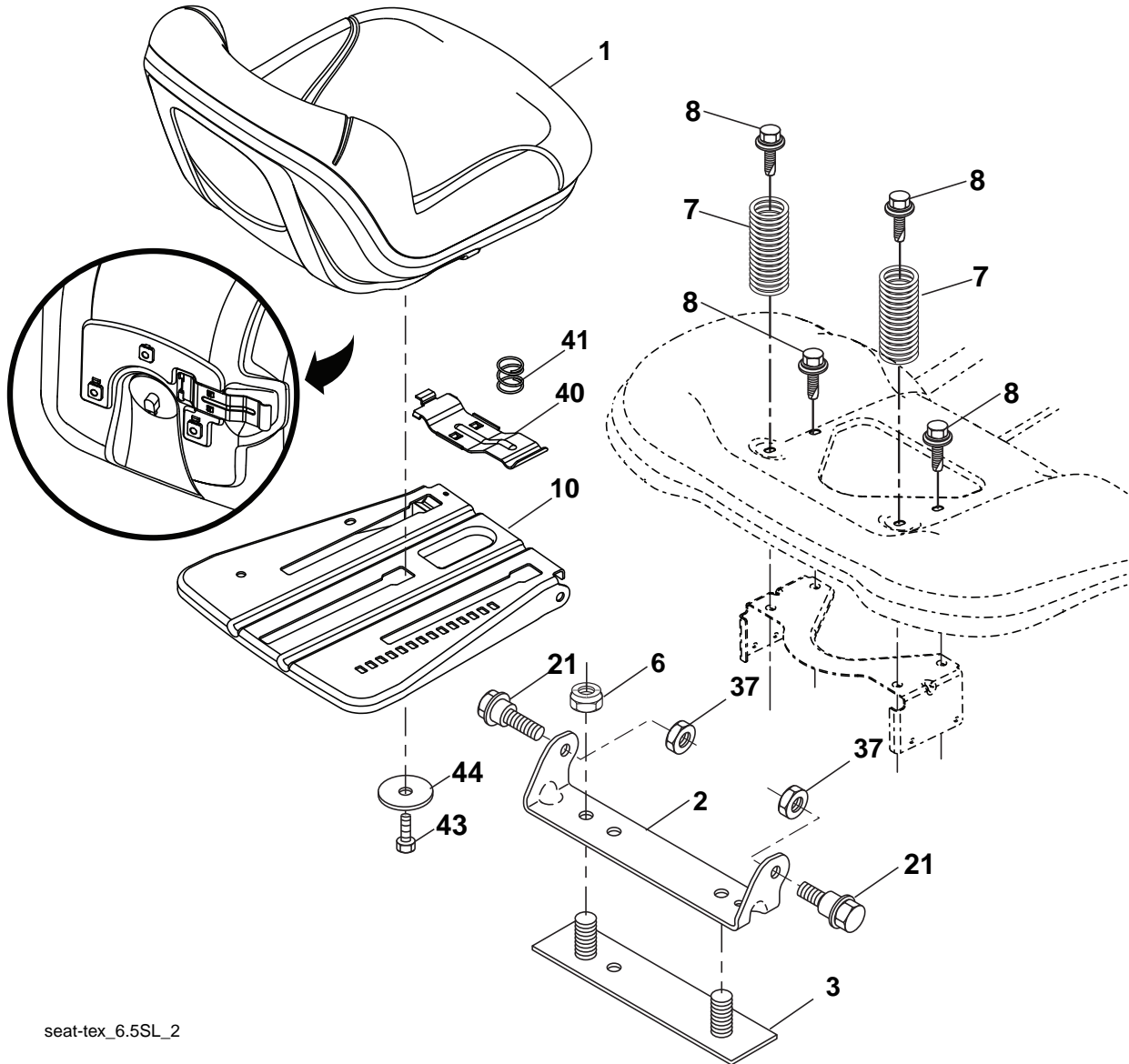

seat-tex_6.5SL_2

KEY NO.	PART NO.	DESCRIPTION
1	532 42 40-68	Seat
2	532 18 01-66	Bracket Pivot Fender
3	532 14 06-75	Strap, Asm Fender
6	873 80 06-00	Nut, Lock w/Ins. 3/8-16 unc
7	532 12 41-81	Spring, Seat Cprsn
8	532 17 18-77	Bolt 5/16-18 unc x 3/4 w/Sems
10	532 19 69-77	Pan, Seat
21	532 17 18-52	Bolt, Shoulder 5/16-18

KEY NO.	PART NO.	DESCRIPTION
37	873 80 05-00	Nut, Lock 5/16-18 unc
40	532 19 76-61	Handle Slide Seat
41	532 19 82-00	Spring Latch Seat
43	874 76 06-12	Bolt 3/8-16 x 3/4
44	819 13 38-12	Washer 13/32 x 2-3/8 x 12 Ga.

NOTE: All component dimensions given in U.S. inches
1 inch = 25.4 mm

