



LTH126

Spare parts

Ersatzteile

Pièces détachées

Reserve onderdelen

Repuestos

Reservdelar

ILLUSTRATED PARTS LIST

MODEL NO. 96041008400
CUSTOMER CATALOG NO. LTH126
PRODUCT NO. 960 41 00-84

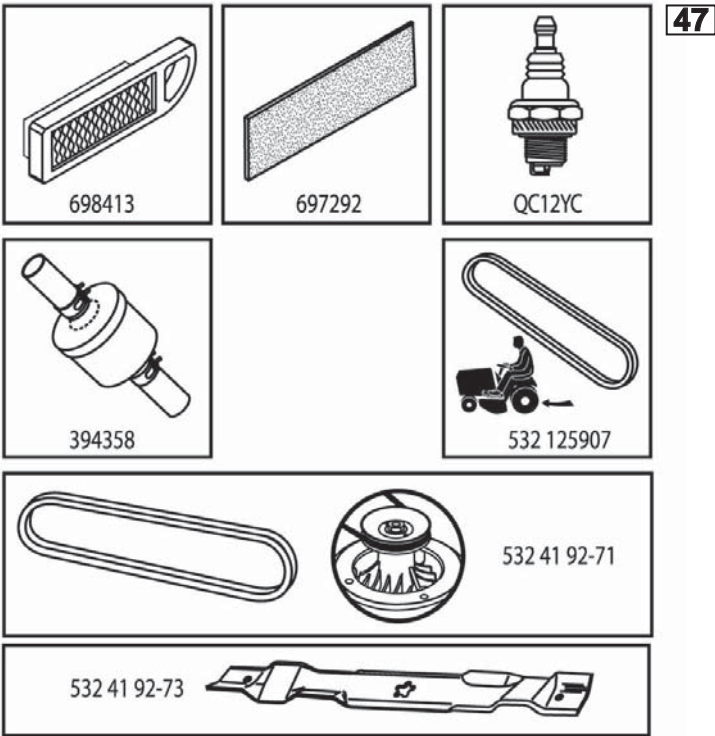

424372

**TRACTOR - - MODEL NO. LTH126 (96041008400), PRODUCT NO. 960 41 00-84
DECALS 27**

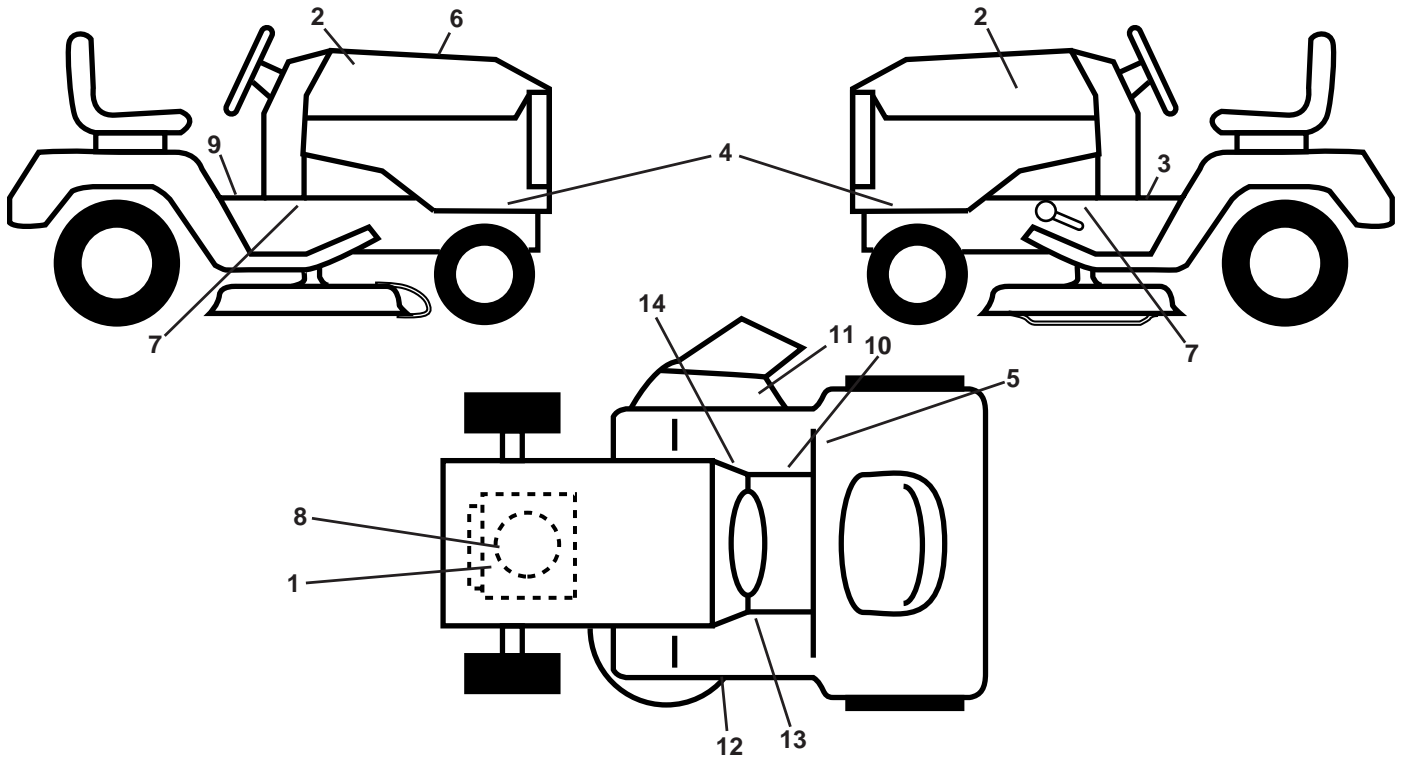

KEY NO.	PART NO.	DESCRIPTION
1	532 19 68-41	Decal, Warning Engine
2	532 42 20-12	Decal, Hood Logo
3	532 40 03-89	Decal, Warning Symbols
4	532 42 51-67	Decal, Hood Panel Side
5	532 18 04-32	Decal, Fender 100 DB/CE
6	532 42 43-72	Decal, Replacement
7	532 15 97-36	Decal, Chassis Hot Muffler
8	532 41 79-27	Decal, Engine
9	532 14 50-05	Decal, Battery Dnge/Poi
10	532 17 83-02	Decal, Oper. Cruise

KEY NO.	PART NO.	DESCRIPTION
11	532 42 51-12	Decal, Warning Deflect/Cutfinger
12	532 42 15-43	Decal, Mower V-Belt Schematic
13	532 15 97-37	Decal, Brake/Clutch
14	532 14 08-37	Decal, Saddle Brake Parking
--	532 16 69-60	Decal, Bypass
--	532 41 08-05	Pad, Footrest, LH
--	532 41 08-06	Pad, Footrest, RH
--	532 16 25-98	Decal, Drawbar Load Limit
--	532 42 26-28	Manual, Operator's (Euro)

WHEELS AND TIRES

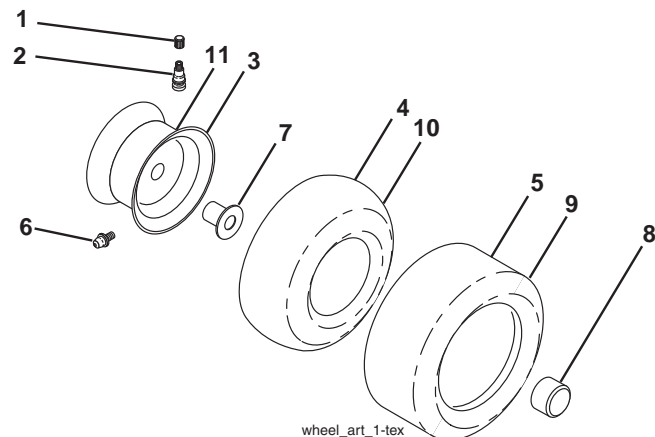

KEY NO.	PART NO.	DESCRIPTION
1	532 05 91-92	Cap Valve Tire
2	532 06 51-39	Stem Valve
3	532 42 52-61	Rim Asm 6" x 3.25 Front
4	532 42 16-52	Tube Front (Service Item Only)
5	532 12 34-10	Tire Front 13 x 5.0-6
6	532 12 49-57	Fitting Grease (Front Wheel Only)
7	532 12 49-59	Bearing Flange (Front Wheel Only)
8	532 17 50-39	Cap Axle Blk 1 50 x 1 00
9	532 10 62-30	Tire Rear 16 x 6 - 5
10	532 12 49-26	Tube Rear (Service Item Only)
11	532 42 52-62	Rim Asm 8" x 5.375 Rear
--	532 14 43-34	Sealant, Tire (10 oz. Tube)

NOTE: All component dimensions given in U.S. inches
1 inch = 25.4 mm

TRACTOR - - MODEL NO. LTH126 (96041008400), PRODUCT NO. 960 41 00-84

SCHEMATIC 38

SCH11

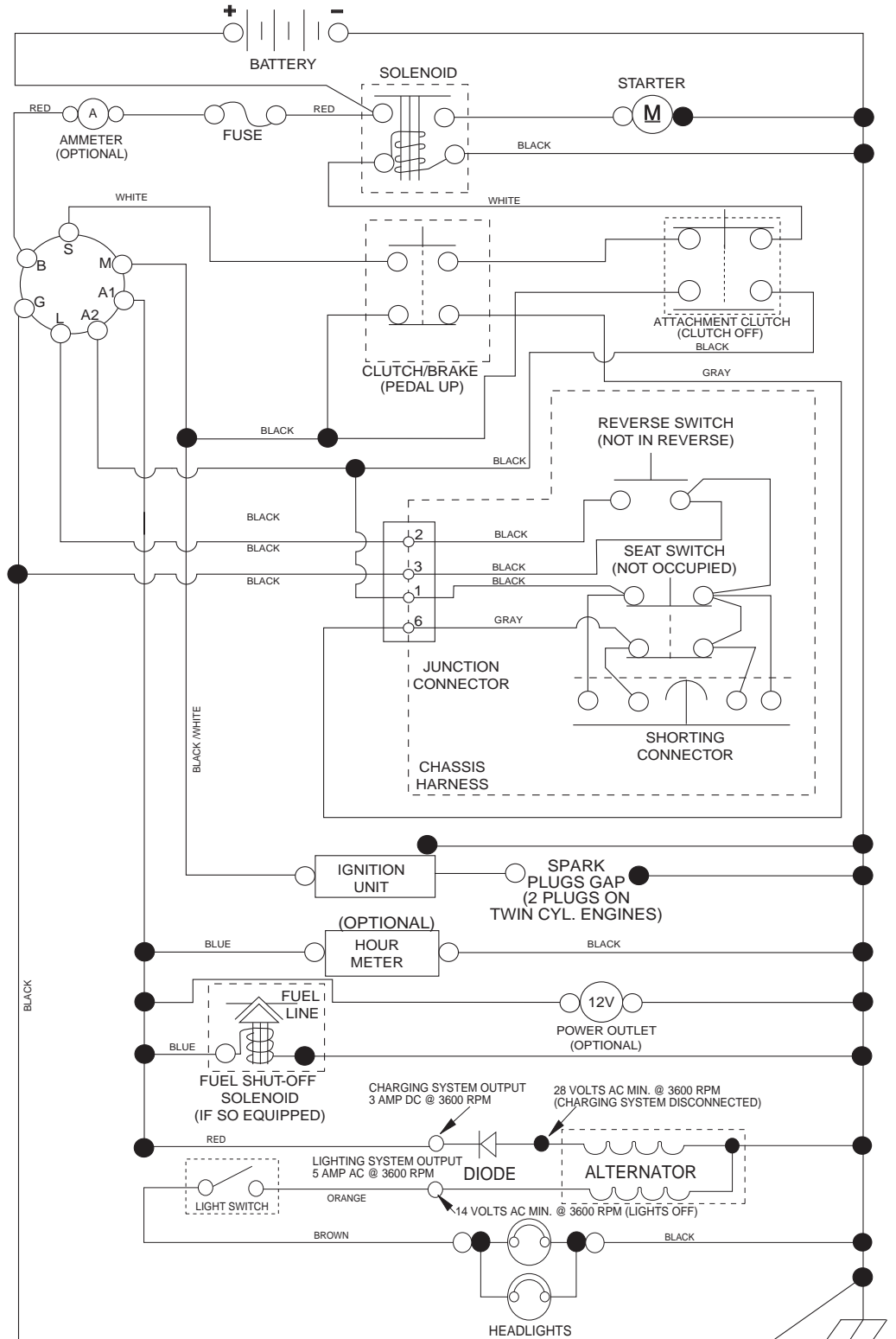

NOTE
YOUR TRACTOR IS EQUIPPED WITH A SPECIAL ALTERNATOR SYSTEM. THE LIGHTS ARE NOT CONNECTED TO THE BATTERY, BUT HAVE THEIR OWN ELECTRICAL SOURCE. BECAUSE OF THIS, THE BRIGHTNESS OF THE LIGHTS WILL CHANGE WITH ENGINE SPEED. AT IDLE THE LIGHTS WILL DIM. AS THE ENGINE IS SPEEDED UP, THE LIGHTS WILL BECOME THEIR BRIGHTEST.

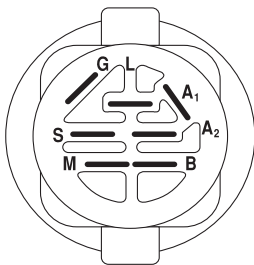

IGNITION SWITCH

POSITION	CIRCUIT "MAKE"
OFF	M+G+A1
RUN/OVERRIDE	B+A1
RUN	B+A1 L+A2
START	B+S+A1

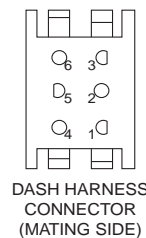
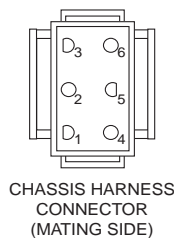

WIRING INSULATED CLIPS
NOTE: IF WIRING INSULATED CLIPS WERE REMOVED FOR SERVICING OF UNIT, THEY SHOULD BE RE-INSTALLED TO PROPERLY SECURE YOUR WIRING.

NON-REMOVABLE CONNECTIONS

REMOVABLE CONNECTIONS

TRACTOR - - MODEL NO. LTH126 (96041008400), PRODUCT NO. 960 41 00-84
ELECTRICAL 32

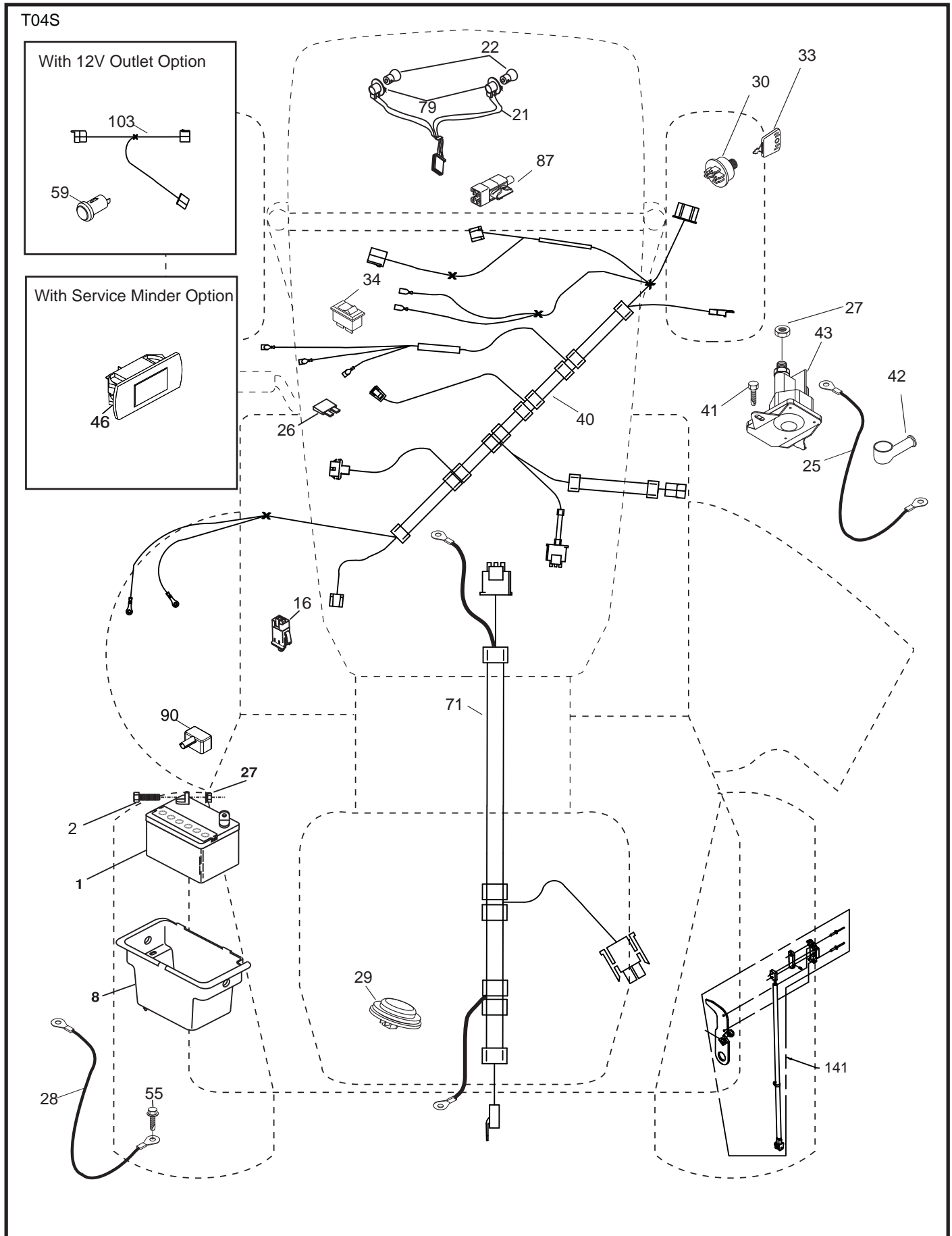

**TRACTOR - - MODEL NO. LTH126 (96041008400), PRODUCT NO. 960 41 00-84
ELECTRICAL 32**

KEY NO.	PART NO.	DESCRIPTION
1	532 14 49-24	Battery
2	874 76 04-12	Bolt Hex Head 1/4-20 x 3/4
8	532 19 32-28	Box Battery
16	532 17 61-38	Switch Interlock Push-In
21	532 40 02-52	Harness Socket Light w/4152J
22	532 00 41-52	Bulb Light
25	532 41 28-94	Cable Starter
26	532 17 51-58	Fuse
27	873 51 04-00	Nut Keps Hex 1/4-20 unc
28	532 19 88-85	Cable, Ground
29	532 40 15-45	Switch, Seat
30	532 19 33-50	Switch, Ign
33	532 41 19-35	Key/Chain
34	532 11 07-12	Switch Light/Reset
40	532 40 10-98	Harness Ign. Dash
41	817 72 04-08	Screw Thd Cut 1/4-20 x 1/2
42	532 13 15-63	Cover, Terminal
43	532 19 25-07	Solenoid
46	532 41 39-31	Gauge Hourmeter
55	817 06 05-12	Screw Thdrol 5/16-18 x 3/4
71	532 40 04-49	Harness Chassis
79	532 17 52-42	Socket Asm Bulb Twistlock
87	532 19 78-02	Switch Interlock Clutch Cable
90	532 40 07-25	Cover, Terminal Battery
141	532 41 69-77	Kit T2 ROS

NOTE: All component dimensions given in U.S. inches
1 inch = 25.4 mm

TRACTOR - - MODEL NO. LTH126 (96041008400), PRODUCT NO. 960 41 00-84
CHASSIS AND ENCLOSURES **39**

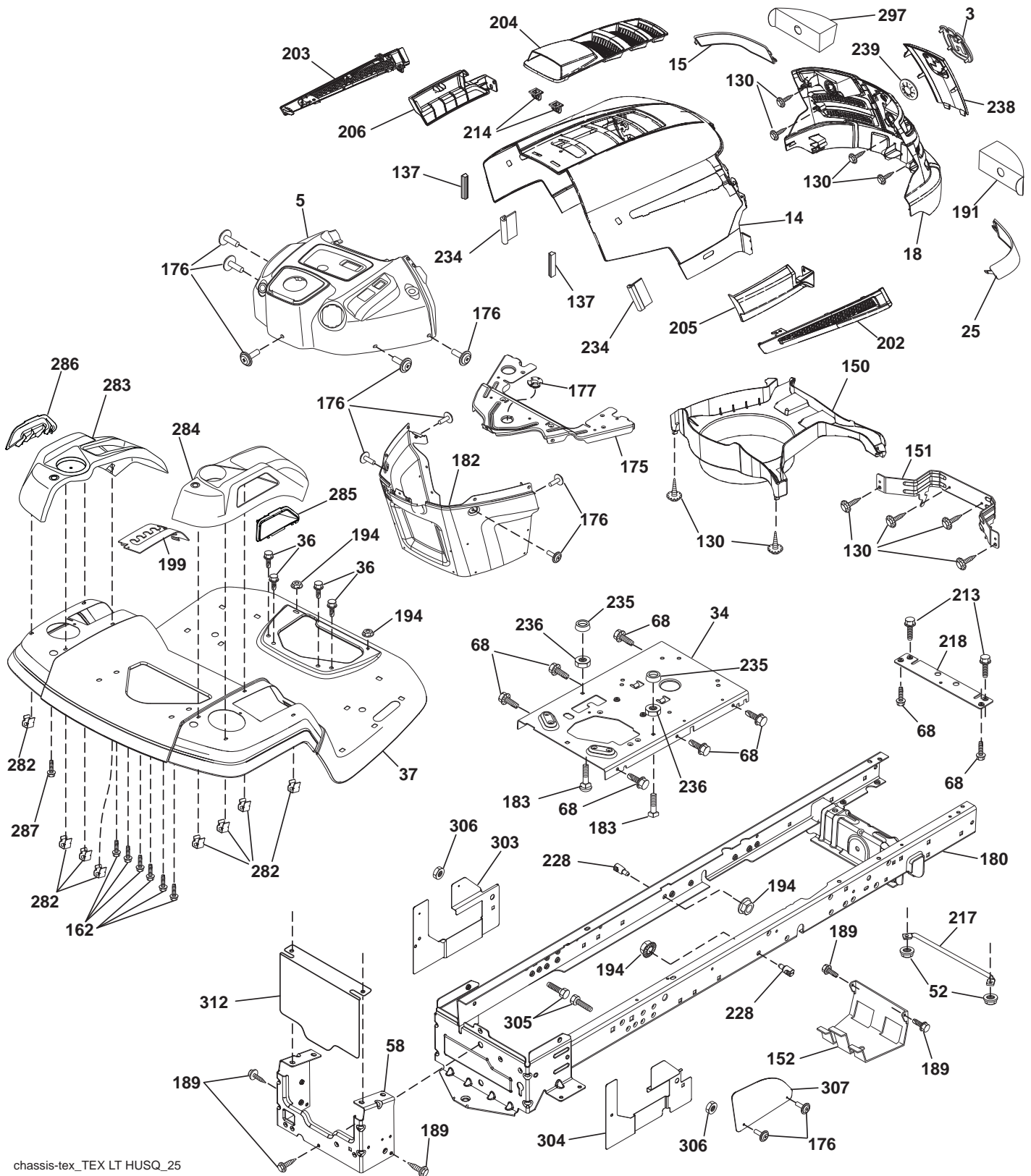

chassis-tex_TEX LT HUSQ_25

**TRACTOR - - MODEL NO. LTH126 (96041008400), PRODUCT NO. 960 41 00-84
CHASSIS AND ENCLOSURES 39**

KEY NO.	PART NO.	DESCRIPTION	KEY NO.	PART NO.	DESCRIPTION
3	532 40 50-12	Logo	204	532 41 11-16	Vent Top Hood
5	532 40 75-92	Dash	205	532 41 10-76	Skirt Side RH
14	532 41 10-73	Hood	206	532 41 10-77	Skirt Side LH
15	532 41 10-79	Lens LH	213	874 76 05-12	Bolt 5/16-18 x 3/4
18	532 40 66-67	Grille/Lens Asm.	214	532 19 91-45	Clip Retainer
25	532 41 10-78	Lens RH	217	532 40 91-67	Rod Pivot Hood
34	532 19 61-25	Plate Engine	218	532 19 63-95	X-Piece Hood Stop
36	817 06 05-12	Screw 5/16-18 x 3/4	228	532 19 51-61	Stud Fastener
37	532 41 63-07	Fender	234	532 40 47-42	Bumper Hood
52	873 68 05-00	Nut Crown Lock 5/16	235	532 40 61-29	Spacer Fender
58	532 41 22-80	Drawbar, Upper	236	873 93 05-00	Nut Lock 5/16-18 unc
68	817 49 05-08	Screw THDROL 5/16-18 x 1/2	238	532 41 11-19	Trim
130	532 41 63-58	Screw #10 x .750 BOS Thread	239	532 40 48-83	Clip Tinnerman
137	532 40 75-90	Bumper Dash	282	532 41 41-10	Clip Retainer Console
150	532 40 66-62	Air Duct	283	532 41 63-16	Console Deck Lift
151	532 40 78-07	Bracket Pivot	284	532 41 78-87	Console Shift
152	532 19 95-35	Shield Browning	285	532 41 63-15	Console Insert RH
162	532 14 24-32	Screw	286	532 41 63-17	Console Insert LH
175	532 19 94-72	Crossmember	287	817 60 04-06	Screw Hex Washhead 1/4-20 x 3/8
176	532 40 07-76	Screw 10-24 x 5/8	288	819 17 16-16	Washer 17/32 x 1 x 16 Ga.
177	532 19 52-28	Bushing Steering	297	532 40 66-65	Insert Reflective LH
180	532 41 46-85	Chassis	303	532 42 51-51	Shield Chassis LH
182	532 40 71-76	Dash Lower	304	532 42 51-52	Shield Chassis RH
183	874 78 05-20	Bolt 5/16-18 unc x 1-1/4	305	872 11 06-06	Bolt Rdhd Sht Sqnk 3/8-16 x 3/4
189	817 00 05-12	Screw 5/16-18 x 3/4	306	873 90 06-00	Nut Lock Flg 3/8-16 unc
191	532 41 65-00	Insert Reflective RH	307	532 42 45-70	Shield Upper Pedal
194	873 90 05-00	Nut Lock Hex Flange 5/16-18	312	532 42 09-60	Shield Drawbar
199	532 41 34-85	Plate Deck Lift			
202	532 41 10-75	Vent Side Hood RH			
203	532 41 10-74	Vent Side Hood LH			

NOTE: All component dimensions given in U.S. inches
1 inch = 25.4 mm

TRACTOR - - MODEL NO. LTH126 (96041008400), PRODUCT NO. 960 41 00-84
DRIVE **40**

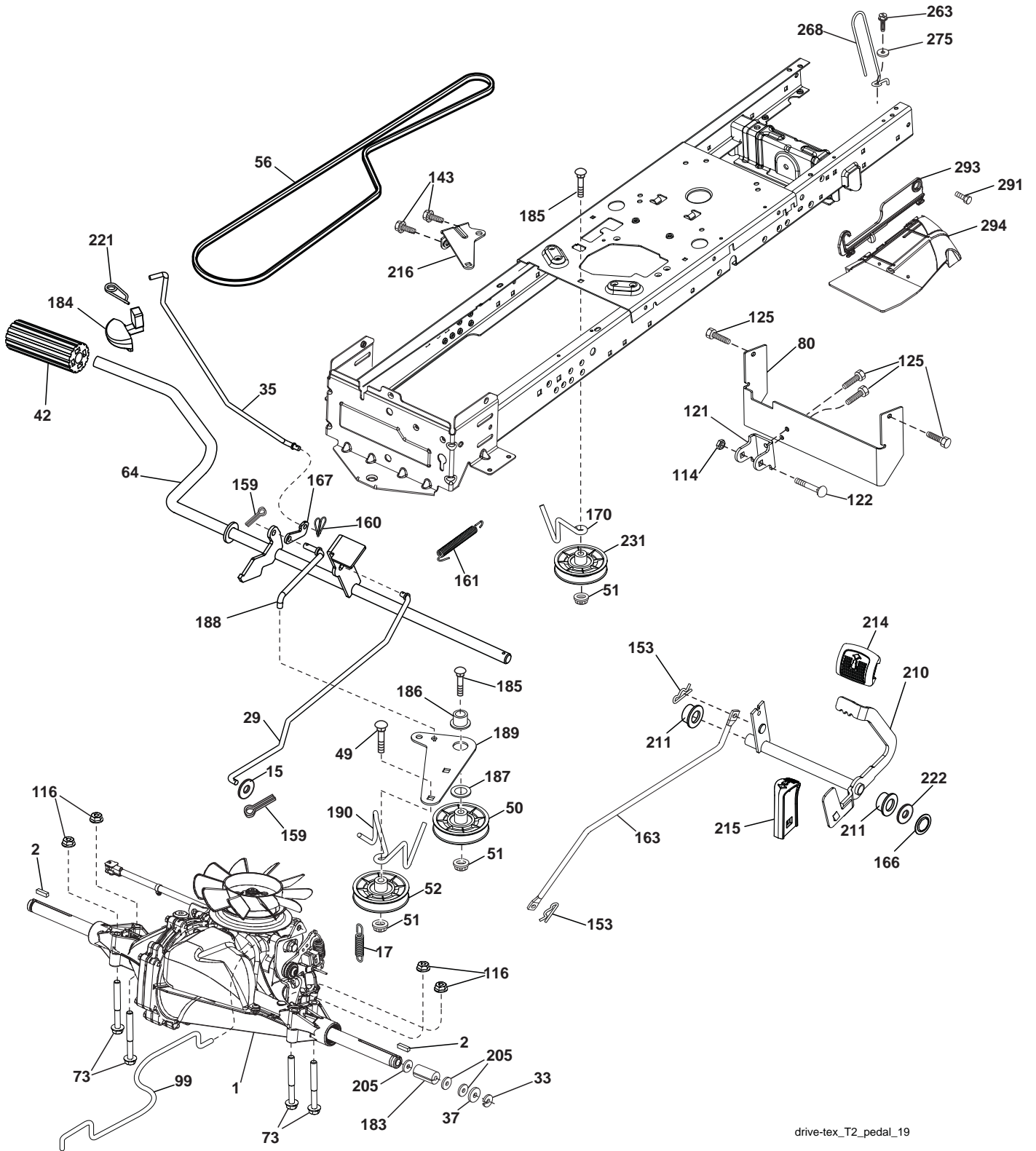

drive-tex_T2_pedal_19

**TRACTOR - - MODEL NO. LTH126 (96041008400), PRODUCT NO. 960 41 00-84
DRIVE **40****

KEY NO.	PART NO.	DESCRIPTION	KEY NO.	PART NO.	DESCRIPTION
1	---	Transaxle, Hydro T2-BABC-1X2B-1GX1	167	532 40 52-57	Latch Brake Parking
2	532 12 35-83	Key	170	532 41 34-30	Keeper Belt Centerspan
15	819 13 13-16	Washer 13/32 x 13/16 x 16 Ga.	183	532 15 69-72	Spacer Axle
17	532 19 72-96	Spring, Brake	184	532 40 97-47	Handle Parking Brake
29	532 40 83-91	Rod, Brake	185	872 11 06-22	Bolt
33	812 00 00-01	Ring E	186	532 19 43-21	Spacer Retainer
35	532 40 10-31	Rod, Brake, Park	187	819 13 32-10	Washer
37	532 12 17-49	Washer 25/32 x 1-1/4 x 16 Ga.	188	532 19 43-23	Link Clutch Ground Drive
42	532 12 48-72	Cover, Foot Pedal	189	532 19 43-17	Bellcrank Ground Drive
49	872 11 06-14	Bolt	190	532 19 43-18	Keeper Bellcrank Ground Drive
50	532 19 43-27	Pulley Idler Flat	205	532 12 17-48	Washer 25/32 x 1-5/8 x 16 Ga.
51	873 90 06-00	Lock Nut 3/8-16	210	532 40 09-80	Rockr Asm. Pdeal Control
52	532 19 43-26	Idler V-Groove 910" Offset	211	532 12 01-83	Bearing Nylon
56	532 12 59-07	V-Belt, Drive	214	532 42 12-63	Pad Pedal Forward
64	532 19 78-65	Shaft Asm. Pedal Brake Control	215	532 40 17-23	Pad Pedal Reverse
73	874 49 05-44	Bolt 5/16-18 Gr. 5	216	532 19 61-31	Bracket Pulley Idler
80	532 40 83-93	Strap Torque	221	532 40 31-87	Retainer Spring Clip Handle
99	532 40 84-18	Rod Asm Bypass Spring	222	879 21 20-10	Washer 21/32 x 1-1/4 10 Ga.
114	873 80 05-00	Nut Lock 5/16-18 unc	231	532 40 72-87	Idler V-Groove 1.688
116	873 90 05-00	Nut Lock Hex Flange 5/16-18	263	817 00 06-12	Screw 3/8-16 x 3/4
121	532 17 56-11	Bracket Strap Torque	268	532 18 24-02	Guard Muffler
122	872 01 05-20	Bolt 5/16-18 x 2.50	275	819 13 16-14	Washer 13/32 x 1 x 14 Ga.
125	817 00 05-12	Screw 5/16-18 x 3/4	291	532 17 01-65	Bolt Shoulder 5/16-18
143	817 49 05-08	Screw Thdrol 5/16-18 x 1/2	293	532 42 25-48	Hinge RH
153	532 12 47-88	Retainer Spring	294	532 42 25-49	Partition Pivoting RH
159	876 02 04-12	Pin Cotter 1/8 x 3/4			
160	532 16 94-84	Retainer Clip			
161	532 10 57-09	Spring, Return, Clutch			
163	532 41 33-22	Rod Pedal Control			
166	532 19 72-90	Nut Push .625			

NOTE: All component dimensions given in U.S. inches
1 inch = 25.4 mm

TRACTOR - - MODEL NO. LTH126 (96041008400), PRODUCT NO. 960 41 00-84
 ENGINE 24

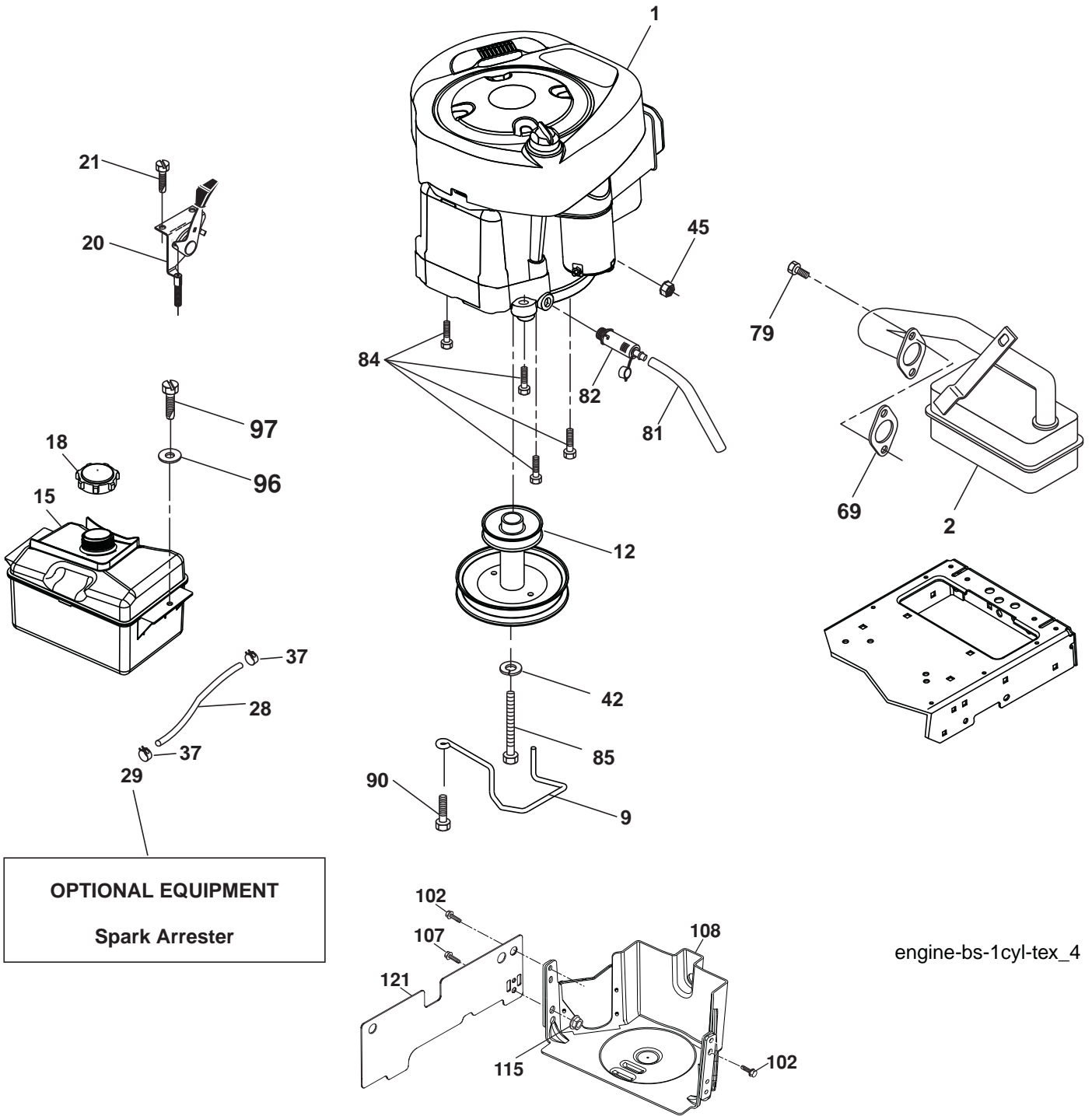

Guard_assembly_30

**TRACTOR - - MODEL NO. LTH126 (96041008400), PRODUCT NO. 960 41 00-84
ENGINE 24**

KEY NO.	PART NO.	DESCRIPTION
1	-----	Engine Briggs Model No. 219807
2	532 17 97-58	Muffler
9	532 19 43-19	Keeper Belt Engine
12	532 14 01-86	Pulley Engine
15	532 40 75-45	Tank Fuel
18	532 19 77-25	Cap Asm
20	532 18 38-97	Control Throttle
21	532 41 63-58	Screw #10 x 0.750 BOS Thread
28	532 13 70-40	Fuel Line
29	532 13 71-80	Spark Arrester Kit
37	532 12 34-87	Clamp Hose
42	810 04 07-00	Washer Lock 7/16
45	873 51 04-00	Nut Keps Hex 1/4-20 unc
69	532 16 52-91	Gasket
79	532 19 23-34	Screw 5/16-18 x 3/4
81	532 14 84-56	Tube Drain Oil Easy
82	532 18 16-54	Plug Drain Oil
84	817 06 06-20	Screw 3/8-16 x 1/4
85	532 17 39-37	Bolt Hex 7/16-20 x 4 Gr. 5
90	817 00 06-16	Screw 3/8-16 x 1
96	819 09 14-16	Washer 9/32 x 7/8 x 16 Ga.
97	817 67 04-12	Screw 1/4-20 x 3/4
102	817 00 05-12	Screw 5/16-18 x 3/4
107	532 13 77-29	Screw THD
108	532 42 30-41	Cover Pulley
115	532 42 30-62	Palnut 1/4"
121	532 42 08-94	Shield SRD LH

NOTE: All component dimensions given in U.S. inches
1 inch = 25.4 mm

Engine Power Rating Information

The gross power rating for individual gas engine models is labeled in accordance with SAE (Society of Automotive Engineers) code J11940 (Small Engine Power & Torque Rating Procedure), and rating performance has been obtained and corrected in accordance with SAE J1995 (Revision 2002-5). Actual gross engine power will be lower and is affected by, among other things, ambient operating conditions and engine-to-engine variability. Given both the wide array of products on which engines are placed and the variety of environmental issues applicable to operating the equipment, the gas engine will not develop the rated gross power when used in a given piece of power equipment (actual "on-site" or net horsepower). This difference is due to a variety of factors including, but not limited to, accessories (air cleaner, exhaust, charging, cooling, carburetor, fuel pump, etc.), application limitations, ambient operating conditions (temperature, humidity, altitude), and engine-to-engine variability. Due to manufacturing and capacity limitations, Briggs & Stratton may substitute an engine of higher rated power for this Series engine.

TRACTOR - - MODEL NO. LTH126 (96041008400), PRODUCT NO. 960 41 00-84
STEERING ASSEMBLY **41**

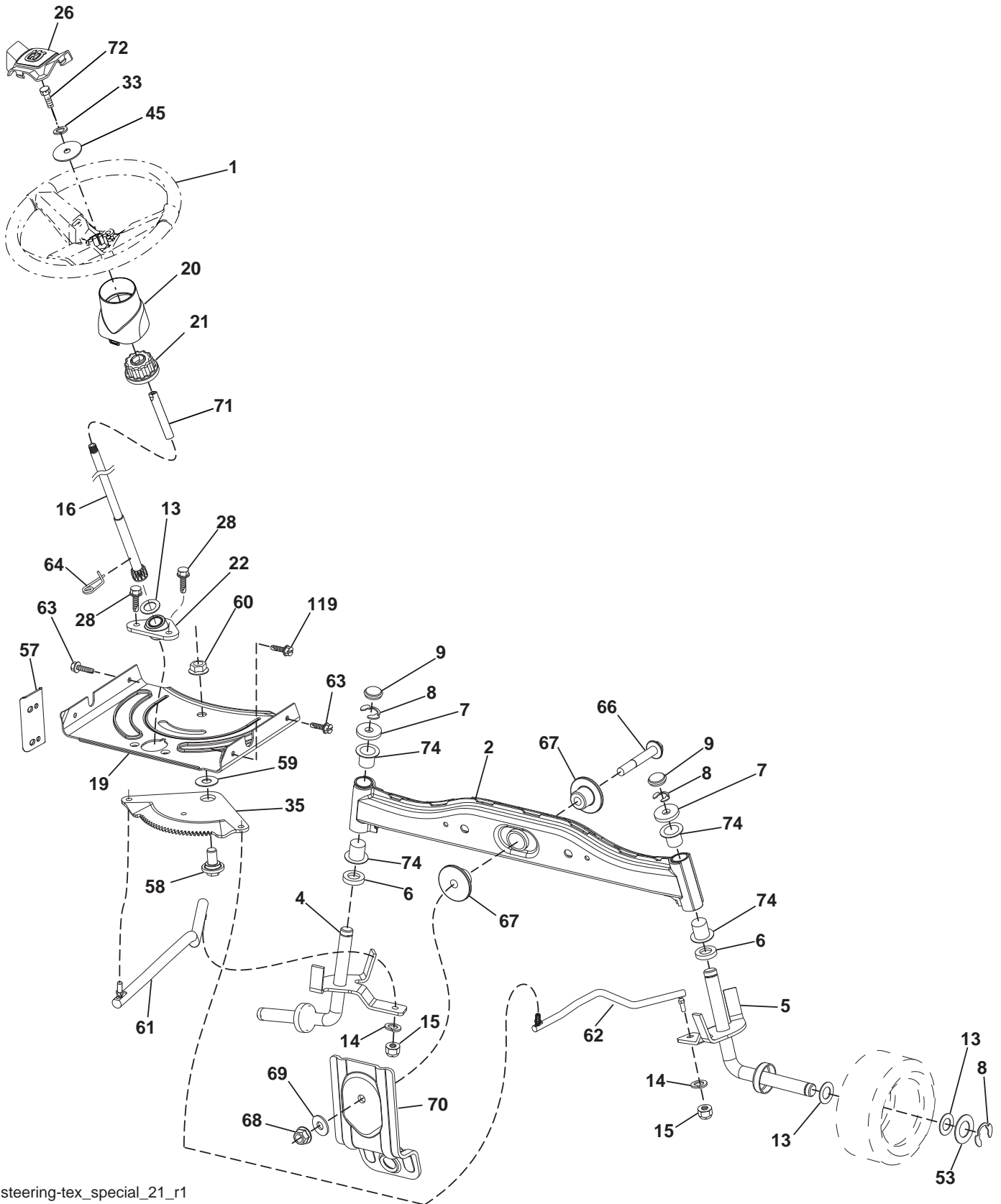

steering-tex_special_21_r1

**TRACTOR - - MODEL NO. LTH126 (96041008400), PRODUCT NO. 960 41 00-84
STEERING ASSEMBLY **41****

KEY NO.	PART NO.	DESCRIPTION
1	532 41 64-80	Wheel, Steering
2	532 41 81-68	Axle Asm., Front
4	532 41 68-45	Spindle Asm., LH
5	532 41 68-46	Spindle Asm., RH
6	532 12 49-31	Washer Thrust
7	532 12 17-48	Washer 25/32 x 1-5/8 x 16 Ga.
8	812 00 00-29	Ring, Klip #T5304-75
9	532 12 12-32	Cap, Spindle
13	532 12 17-49	Washer 25/32 x 1-1/4 x 16 Ga.
14	810 04 06-00	Washer, Lock Hvy Hlcl Spr 3/8
15	873 54 06-00	Nut, Crown Lock 3/8-24 unf
16	532 19 60-74	Shaft Steering
19	532 19 47-29	Plate Steering
20	532 41 11-39	Boot, Steering
21	532 18 67-37	Adapter, Wheel Steering
22	532 19 48-45	Bushing, Strg. Blk
26	532 41 59-87	Insert, Wheel Steering
28	817 00 06-12	Screw 3/8-16 x 3/4
33	810 04 05-00	Washer Lock 5/16
35	532 19 47-32	Gear, Sector Plate
45	819 11 38-12	Washer 11/32 x 3/8 x 12 Ga.
53	532 18 89-67	Washer Hardened .793 x 1.637 x .060
57	532 40 74-65	Bracket Upstop
58	532 19 47-47	Bolt Shoulder Sector Pivot CFM
59	532 19 47-48	Washer Thrust Sector Steering
60	873 97 10-00	Nut Flange Lock 5/8-11
61	532 19 47-40	Draglink, LH
62	532 19 47-41	Draglink, RH
63	817 00 05-12	Screw 5/16-18 x 3/4
64	532 19 98-49	Retainer Clip Spring Steering
66	871 02 07-48	Bolt Hex Fghd 7/16-14 x 3 Serr
67	532 19 47-37	Bushing PM Front Axle
68	873 90 07-00	Nut Lock Flange 7/16-14 Gr. 5
69	532 19 91-62	Washer 1.5 x .505 x .118
70	532 41 70-65	Bracket Deck Susp. Front
71	532 19 60-75	Shaft Extension Steering
72	874 78 05-72	Bolt 5/16-18 unc x 4.5. Gr. 5
74	532 12 49-37	Bearing
119	532 17 01-65	Bolt Shoulder 5/16-18

NOTE: All component dimensions given in U.S. inches
1 inch = 25.4 mm

TRACTOR - - MODEL NO. LTH126 (96041008400), PRODUCT NO. 960 41 00-84
MOWER DECK 44

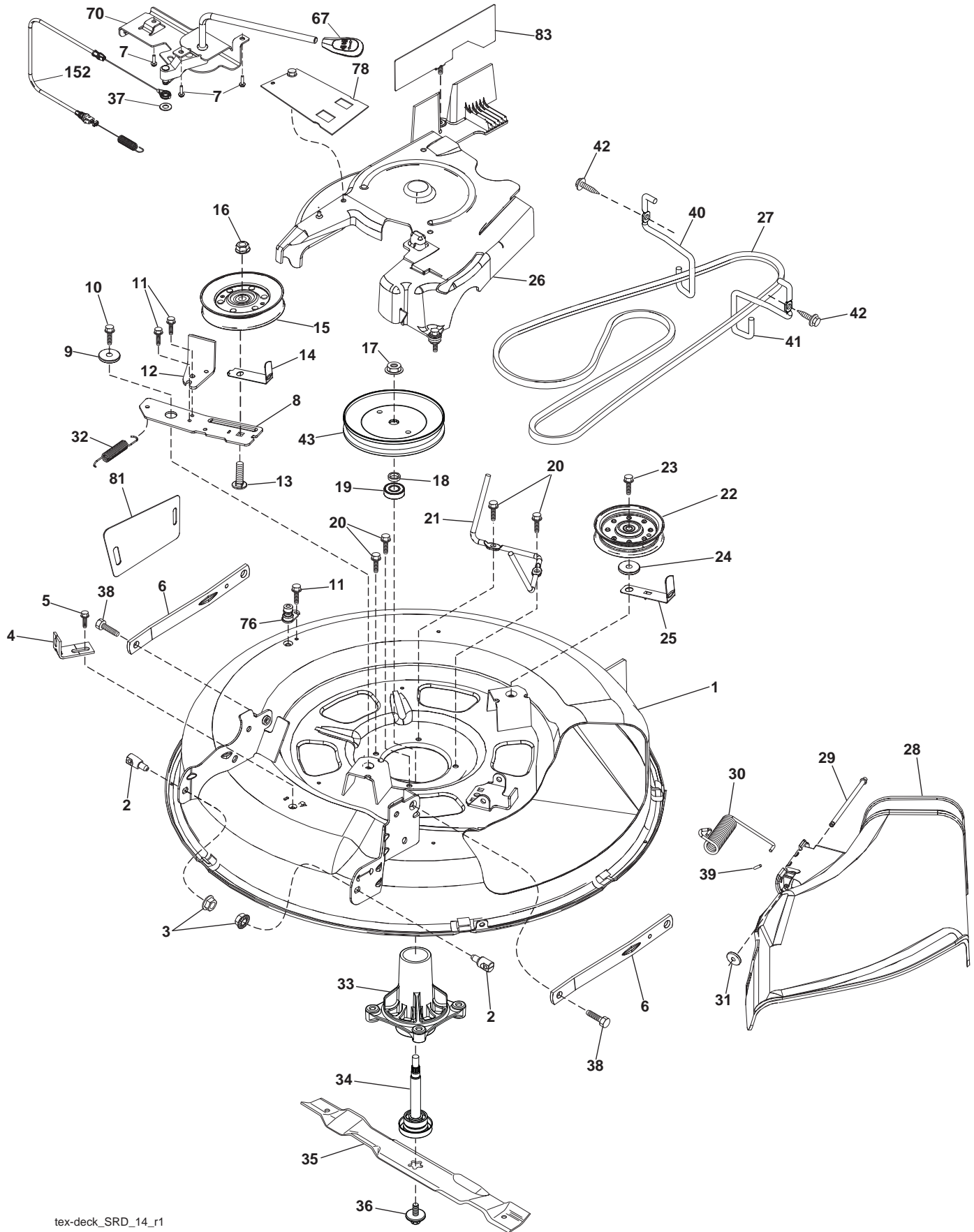

tex-deck_SRD_14_r1

**TRACTOR - - MODEL NO. LTH126 (96041008400), PRODUCT NO. 960 41 00-84
MOWER DECK 44**

KEY NO.	PART NO.	DESCRIPTION	KEY NO.	PART NO.	DESCRIPTION
1	532 41 92-72	Deck Weldment 30"Srd	33	532 18 72-81	Housing Mandrel 4pt Service
2	532 19 51-61	Stud Fastner w/"D'anti-Rotatio	34	532 19 28-72	Shaft Asm Mndrl N/Greaseable38
3	873 90 05-00	Nut Lock Hex Flange 5/16 - 18	35	532 41 92-73	Blade Mower Hp/Mulch Srd
4	532 41 76-45	Bracket Clutch Cable	36	532 19 30-03	Bolt/Washer Asm 7/16 - 20 unf
5	817 00 05-10	Bolt 5/16-18	37	819 13 13-16	Washer 13/32 x 13/16 x 16 Ga.
6	532 41 88-63	Arm Susp Mower Rear Srd	38	532 19 65-39	Bolt Shoulder
7	532 41 63-58	Screw #10 x 0.750 BOS Thread	39	532 10 53-04	Cap Sleeve
8	532 42 02-52	Arm Idler 30"Srd	40	532 41 92-70	Keeper Belt Engine LH
9	532 19 90-92	Spacer Retainer	41	532 41 92-65	Keeper Belt Engine RH
10	817 00 06-16	Screw 3/8 - 16 X 1 Smgml Tap/R Blk	42	817 00 06-12	ScrewHexwsh THDR3/8-16x3/4BL
11	532 13 77-29	Screw Thd Roll 1/4 - 20 X 5/8	43	532 41 68-77	Pulley Mandrel 6 5 Pd 30"
12	532 19 94-70	Arm Brake Mower 38" RH Tex	67	532 40 30-12	Handle clutch cable
13	872 11 06-12	Bolt Carr Sh 3/8 - 16 X 1 - 1/2 Gr5	70	532 40 12-46	Clutch Asm. Manual
14	532 15 60-85	Keeper Belt Idler	76	532 41 55-98	Washout Port
15	532 14 67-63	Pulley Idler V-Groove Dim 4.25	78	532 42 25-66	Guard Deck SRD Arm Clutch
16	873 90 06-00	Nut Lock FIG 3/8 - 16 unc	81	532 42 53-67	Shield Asm. Suspension
17	532 40 02-34	Nut Flange Lock Top	83	532 43 24-67	Asm. Shield
18	532 18 76-90	Washer Spacer Mandrel	152	532 40 87-14	Manual Clutch Cable
19	532 11 04-85	Bearing Ball Mandrel	--	532 41 64-05	Quick Connect Coupling
20	532 17 39-84	Screw Thd Roll Dod Pt Hex	--	532 19 28-70	Mandrel Assembly (Includes Hous- ing, Shaft Assembly, And Bearing Only - Pulley/Nut/Washer And Blade Bolt/Washers Not Included)
21	532 41 69-10	Keeper Belt Mandrel 30"	--	532 42 16-96	Replacement Mower Complete
22	532 19 31-98	Pulley Idler Flat Unplated			
23	817 49 06-28	Screw Thdrol 3/8 - 16 X 1-3/4			
24	819 13 20-12	Washer 13/32 X 1 - 1/4 X 12 Ga			
25	532 42 02-53	Keeper Belt 30"Srd			
26	532 43 24-66	Cover Mandrel Mwr 30"Black			
27	532 41 92-71	V-Belt Drive			
28	532 42 47-69	Shield Asm Deflect Mwr 30s Blk			
29	532 42 08-95	Pin Hinge 30			
30	532 19 70-26	Spring Torsion Dfl 38/42/46 Gr			
31	532 11 04-52	Nut Push Phos & Oil			
32	532 40 18-72	Spring Return Deck 38/46"			

NOTE: All component dimensions given in U.S. inches
1 inch = 25.4 mm

TRACTOR - - MODEL NO. LTH126 (96041008400), PRODUCT NO. 960 41 00-84
SEAT ASSEMBLY 42

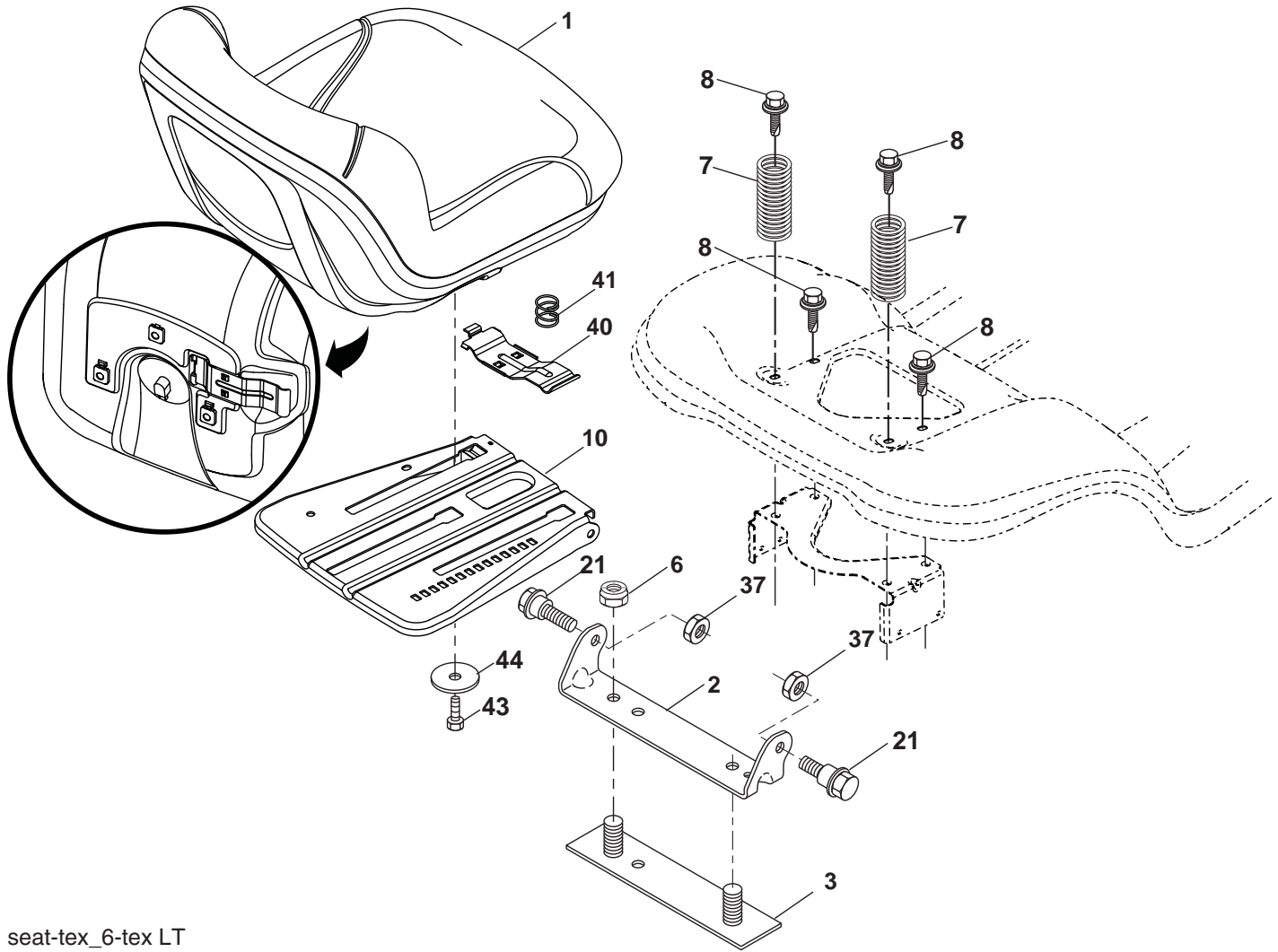

seat-tex_6-tex LT

KEY NO.	PART NO.	DESCRIPTION
1	532 19 75-18	Seat
2	532 18 01-66	Bracket Pivot Fender
3	532 14 06-75	Strap, Asm Fender
6	873 80 06-00	Nut, Lock w/Ins. 3/8-16 unc
7	532 12 41-81	Spring, Seat Cprsn
8	532 17 18-77	Bolt 5/16-18 unc x 3/4 w/Sems
10	532 19 69-77	Pan, Seat
21	532 17 18-52	Bolt, Shoulder 5/16-18

KEY NO.	PART NO.	DESCRIPTION
37	873 80 05-00	Nut, Lock 5/16-18 unc
40	532 19 76-61	Handle Slide Seat
41	532 19 82-00	Spring Latch Seat
43	874 76 06-12	Bolt Fin Hex 3/8-16 unc x 3/4
44	819 13 38-12	Washer 13/32 x 2-3/8 x 12 Ga.

NOTE: All component dimensions given in U.S. inches
 1 inch = 25.4 mm

TRACTOR - - MODEL NO. LTH126 (96041008400), PRODUCT NO. 960 41 00-84
MOWER LIFT 45

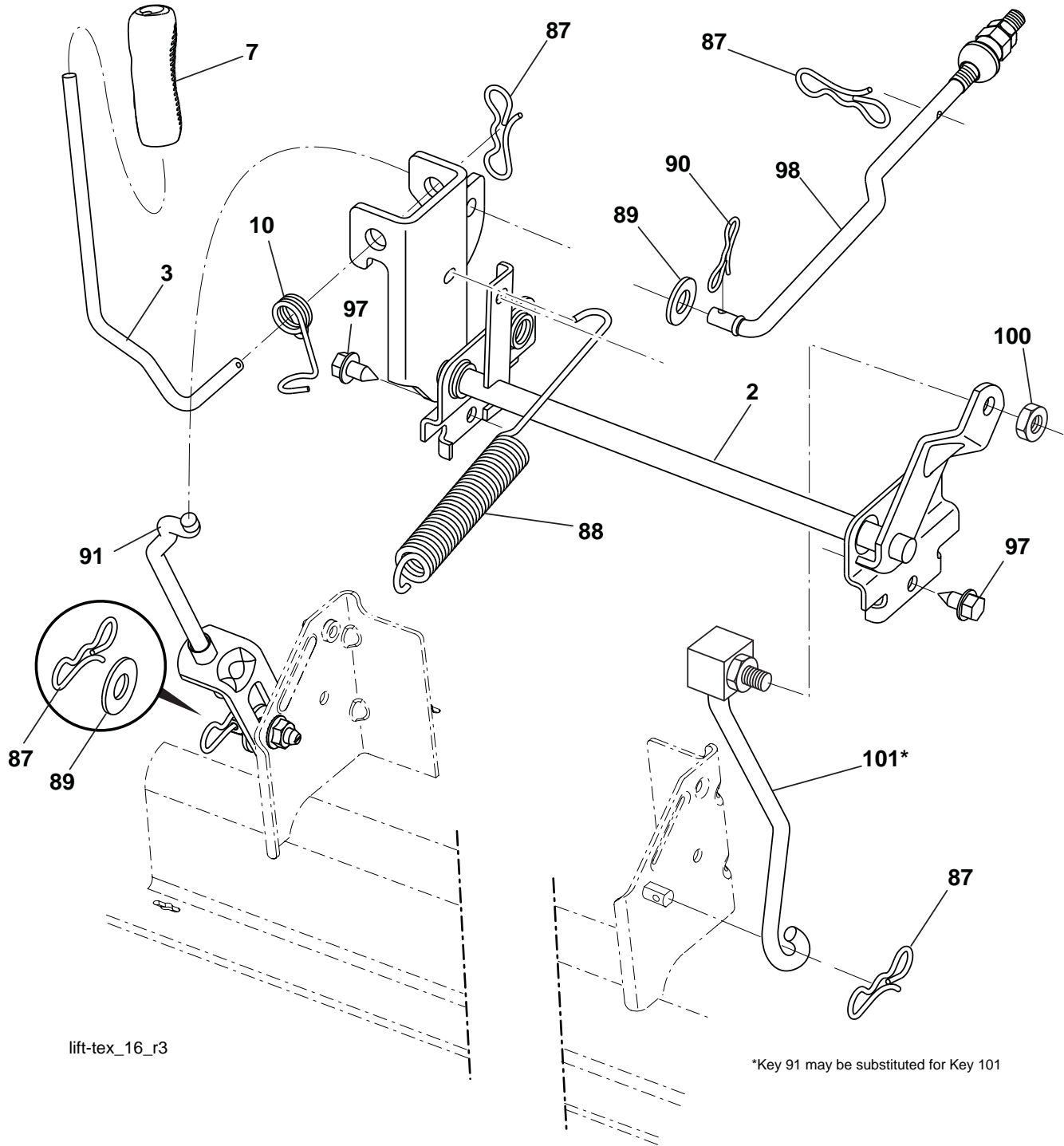

lift-tex_16_r3

*Key 91 may be substituted for Key 101

KEY NO.	PART NO.	DESCRIPTION
2	532 19 52-23	Shaft Asm., Lift
3	532 19 52-31	Lever Asm., Lift RH
7	532 41 15-55	Grip, Lever
10	532 19 63-14	Spring Torsion
87	532 19 42-09	Pin Cotter 7/16 Bow Tie Lock
88	532 41 07-10	Spring Lift Assist
89	819 19 19-12	Washer Clear Zinc
90	532 19 42-08	Pin Cotter 5/16 Bow Tie Lock

KEY NO.	PART NO.	DESCRIPTION
91	532 19 51-81	Link Asm Lift LH Rear
97	817 00 06-12	Screw Hex Wsh. THDR 3/8-16 x 3/4
98	532 19 52-64	Link Lift Susp. Front Mower
100	873 93 06-00	Nut Centerlock 3/8-16 unc
101	532 40 70-03	Link Asm Lift FXD

NOTE: All component dimensions given in U.S. inches
 1 inch = 25.4 mm

