

# GTH26V48LS

---

Illustrated Parts List / 96043009000 / 2009-12

**TRACTOR - MODEL NO. GTH26V48LS (96043009000), PRODUCT NO. 960 43 00-90  
DECALS**

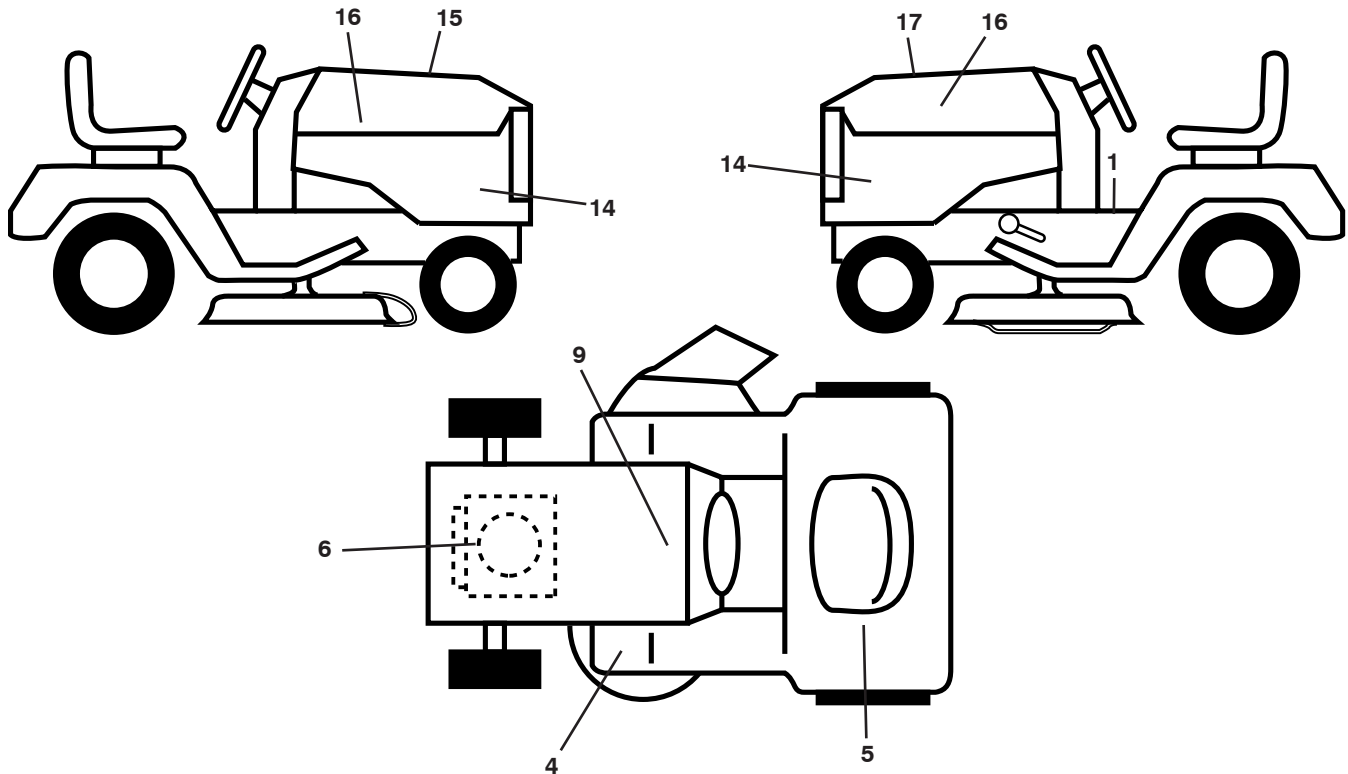

KEY NO.	PART NO.	DESCRIPTION
1	532 41 16-58	Decal, Operator's
4	532 41 86-00	Decal, Pedal
5	532 42 62-09	Decal, Warning Reserve
6	532 43 29-17	Decal, Eng. H.P.
9	532 14 50-05	Decal, Battery Dnge/Poi
14	532 43 27-35	Decal, Panel Side
15	532 42 38-29	Decal, Cust. Resp.
16	532 42 91-96	Decal, Hood Logo

KEY NO.	PART NO.	DESCRIPTION
17	532 43 27-20	Decal, Replacement
--	532 42 38-30	Decal Ethanol E85 Warning
--	532 16 69-60	Decal, Bypass
--	532 40 17-71	Pad, Footrest, LH
--	532 40 37-73	Pad, Footrest, RH
--	532 43 27-87	Manual, Owner's (Eng)
--	532 43 27-88	Manual, Owner's (Fr)

**WHEELS AND TIRES**

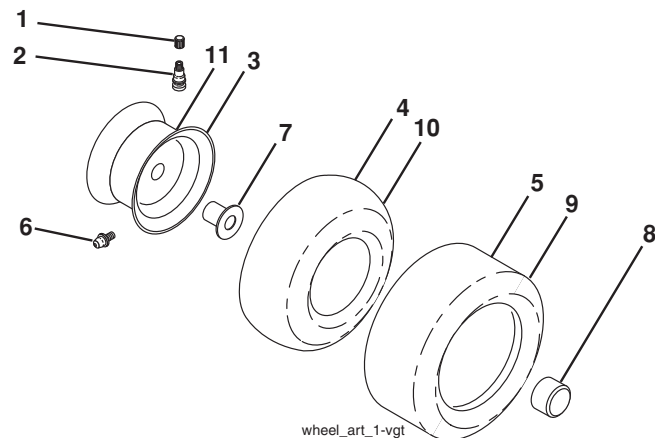

KEY NO.	PART NO.	DESCRIPTION
1	532 05 91-92	Cap, Valve, Tire
2	532 06 51-39	Stem, Valve
3	532 18 18-39	Rim Assembly, Front
4	532 00 81-34	Tube, Front (Service Item Only)
5	532 16 10-24	Tire, Front
6	532 12 49-57	Fitting, Grease (Front Wheel Only)
7	532 12 49-59	Bearing, Flange (Front Wheel Only)
8	532 17 50-39	Cap, Axle (Front Wheel Only)
9	532 17 04-53	Tire, Rear
10	532 00 71-54	Tube, Rear (Service Item Only)
11	532 14 45-10	Rim Assembly, Rear
--	532 14 43-34	Sealant, Tire (10 oz. Tube)

**NOTE:** All component dimensions given in U.S. inches  
1 inch = 25.4 mm

# TRACTOR - MODEL NO. GTH26V48LS (96043009000), PRODUCT NO. 960 43 00-90 SCHEMATIC

SCH12

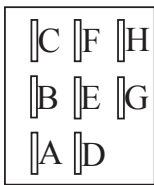
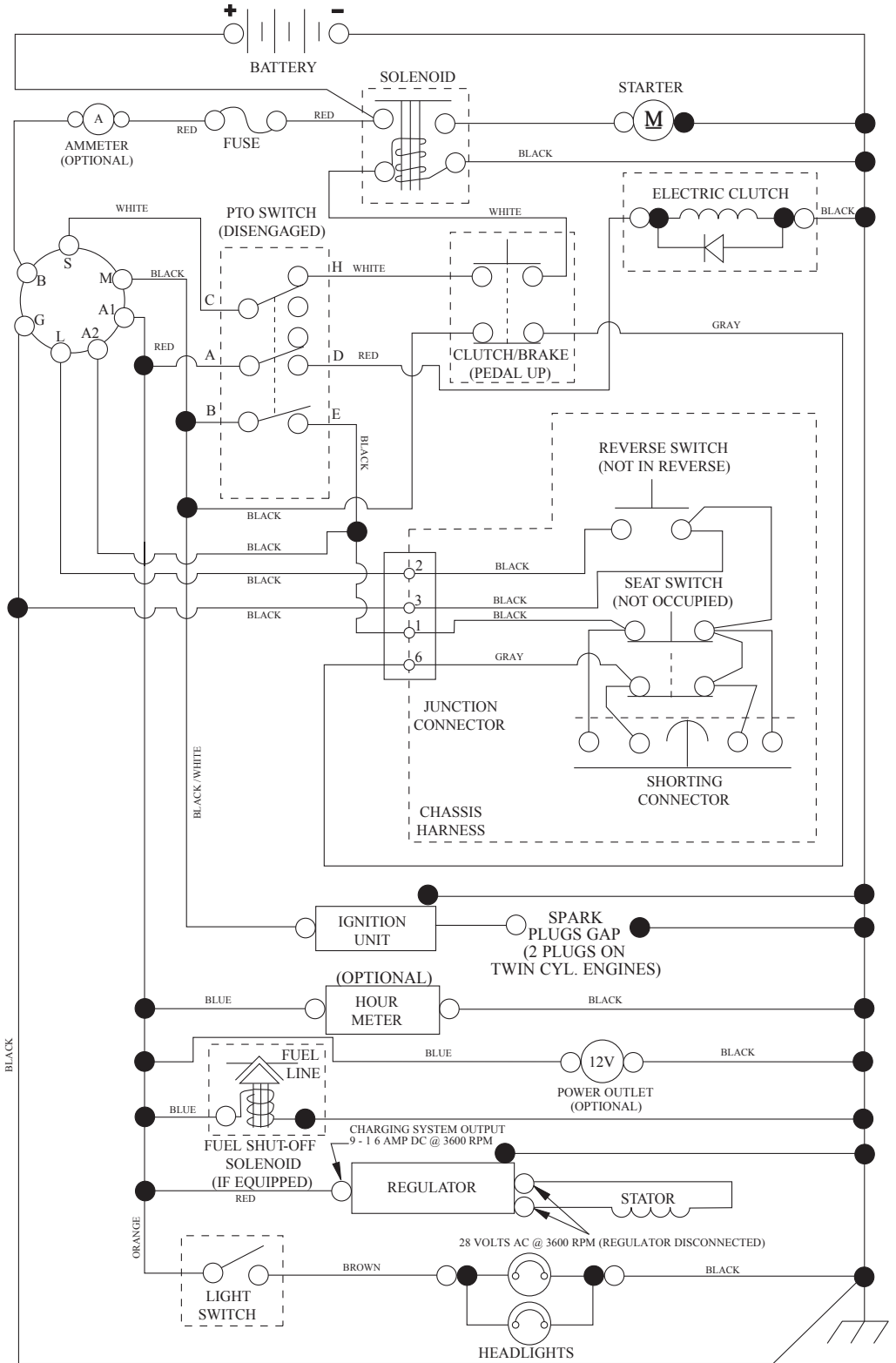

PTO SWITCH  
(MATING SIDE)

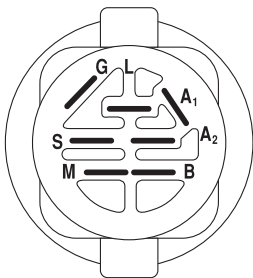

IGNITION SWITCH

POSITION	CIRCUIT	"MAKE"
OFF	M+G+A1	
RUN/OVERRIDE	B+A1	
RUN	B+A1	L+A2
START	B + S + A1	

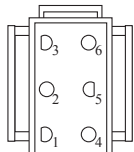

CHASSIS HARNESS  
CONNECTOR  
(MATING SIDE)

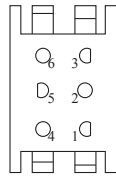

DASH HARNESS  
CONNECTOR

WIRING INSULATED CLIPS  
NOTE: IF WIRING INSULATED  
CLIPS WERE REMOVED FOR  
SERVICING OF UNIT, THEY  
SHOULD BE RE-INSTALLED TO  
PROPERLY SECURE YOUR  
WIRING.

●  
NON-REMOVABLE  
CONNECTIONS

○  
REMOVABLE  
CONNECTIONS

**TRACTOR - MODEL NO. GTH26V48LS (96043009000), PRODUCT NO. 960 43 00-90  
ELECTRICAL**

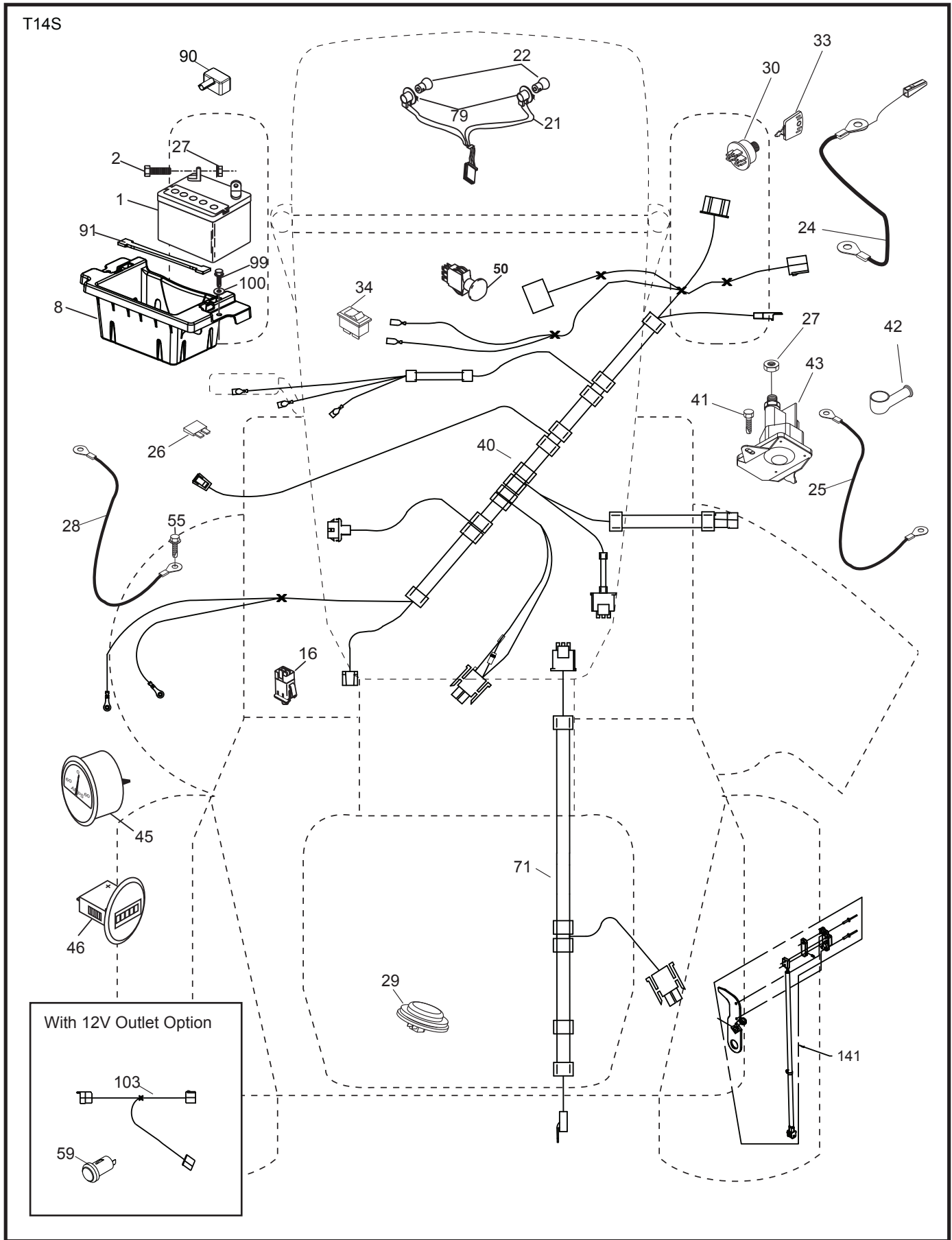

**TRACTOR - MODEL NO. GTH26V48LS (96043009000), PRODUCT NO. 960 43 00-90  
ELECTRICAL**

<b>KEY NO.</b>	<b>PART NO.</b>	<b>DESCRIPTION</b>
1	532 16 34-65	Battery
2	874 76 04-12	Bolt Hex Hd 1/4-20 unc x 3/4
8	532 18 64-91	Battery Box
16	532 17 61-38	Switch Interlock
21	532 18 37-59	Harness Socket Light
22	532 00 41-52	Bulb, Light #1156
24	532 40 02-53	Cable Battery
25	532 41 28-95	Cable Starter
26	532 17 51-58	Fuse
27	873 51 04-00	Nut Keps Hex 1/4-20 unc
28	532 14 54-91	Cable Ground 21" Blk 6 Ga.
29	532 40 15-45	Switch Seat
30	532 19 33-50	Switch Ign
33	532 41 19-35	Key/Chain
34	532 11 07-12	Switch Light/Reset
40	532 40 21-67	Harness Ign. Dash
41	817 72 04-08	Screw 1/4-20 unc x 1/2
42	532 13 15-63	Cover Terminal Red
43	532 19 25-07	Solenoid
45	532 42 52-70	Ammeter Round
46	532 42 52-71	Gauge Hourmeter
50	532 17 46-51	Switch PTO
55	817 06 05-12	Screw Thdrol 5/16-18 x 3/4
59	532 40 03-03	Outlet 12-Volt
71	532 19 42-76	Harness Ign
79	532 17 52-42	Socket Asm. Bulb Twistlock
90	532 40 07-24	Cover Terminal Battery
91	532 19 02-70	Strap Battery
99	817 67 04-12	Screw Hexwsh Thdrol 1/4-20 x 3/4
100	819 09 14-16	Washer 9/32 x 7/8 x 16 Ga.
103	532 42 17-47	Harness Pigtail 12V Outlet
141	532 42 12-25	Kit G700/G730 ROS

**NOTE:** All component dimensions given in U.S. inches  
1 inch = 25.4 mm



**TRACTOR - MODEL NO. GTH26V48LS (96043009000), PRODUCT NO. 960 43 00-90  
CHASSIS**

KEY NO.	PART NO.	DESCRIPTION
2	532 19 42-61	Drawbar
3	532 40 50-12	Logo Husq.
5	532 40 86-98	Dash
14	532 41 10-46	Hood
15	532 19 89-07	Lens LH
18	532 40 86-07	Grille Asm
25	532 19 89-06	Lens RH
36	817 06 05-12	Screw 5/16-18 x 3/4
37	532 40 18-25	Fender
58	532 19 43-14	Bracket Fender
68	817 49 05-08	Screw 5/16-18 x 1/2
130	532 41 63-58	Screw #10 x 0.750 BOS Thread
137	532 40 75-90	Bumper Dash
150	532 19 85-12	Duct Heat Hood
152	532 19 43-29	Shield Browning/Debris
159	817 00 06-12	Screw 3/8-16 x 3/4
161	532 40 18-26	Console Fuel Window
162	532 14 24-32	Screw Hex Wsh Hi-Lo 1/4 x 1/2
165	532 19 43-30	Bracket Support Tank
175	532 19 63-04	Crossmember
176	532 40 07-76	Screw 10-24 x 5/8 Wshd Qdrx
177	532 19 52-27	Bushing Steering
178	532 19 97-82	Cargo Asm. Net
180	532 19 42-60	Chassis
181	532 40 30-25	Bushing Mtg. Fender Crgo.
182	532 40 68-59	Dash Lower
183	874 52 05-20	Bolt 5/16-18 x 1-1/4
189	817 00 05-12	Screw 5/16-18 x 3/4

KEY NO.	PART NO.	DESCRIPTION
194	873 90 05-00	Nut Lock Hex Flange 5/16-18
196	532 41 77-78	Console Asm. Deck Lift
199	532 19 82-59	Plate Deck Lift
202	532 40 30-48	Vent Side Hood RH
203	532 40 30-76	Vent Side Hood LH
204	532 41 66-13	Vent Asm Hood Top
205	532 40 17-09	Skirt Hood Side RH
206	532 40 17-11	Skirt Hood Side LH
207	532 19 71-98	Bezel RH
208	532 19 71-99	Bezel LH
209	532 19 91-30	Insert Hex Top RH
210	532 19 91-31	Insert Hex Top LH
211	532 19 91-32	Insert Hex Bottom RH
212	532 19 91-33	Insert Hex Bottom LH
214	532 19 91-45	Clip Retainer
217	532 40 91-67	Rod Pivot
221	532 19 89-09	Reflector LH
228	532 19 51-61	Stud Fastener
233	532 19 65-39	Bolt Shoulder
234	532 40 47-42	Bumper Hood
235	532 40 61-29	Spacer Fender
236	873 93 05-00	Nut Center Lock 5/16-18 unc
238	532 40 86-06	Trim Husq.
298	532 11 04-52	Nut Push
--	532 43 18-82	Kit Gaurd Brush

**NOTE:** All component dimensions given in U.S. inches  
1 inch = 25.4 mm





# TRACTOR - MODEL NO. GTH26V48LS (96043009000), PRODUCT NO. 960 43 00-90 DRIVE

KEY NO.	PART NO.	DESCRIPTION	KEY NO.	PART NO.	DESCRIPTION
1	-----	Transaxle, Hydro G7-BCBB-1XDC-1FCA	159	876 02 04-12	Pin Cotter 1/8 x 3/4
2	532 00 70-70	Key 1/4 x 2.5	160	532 16 94-84	Retainer Clip
3	532 00 75-63	Washer Thrust Axle Hardened	161	532 10 57-09	Spring, Return, Clutch
7	532 19 98-37	Hub Asm. Wheel	163	532 41 81-85	Rod Pedal Control
9	532 14 00-80	Bolt Hub Wheel	166	532 42 91-64	Nut Push .625
15	819 13 13-16	Washer 13/32 x 13/16 x 16 Ga.	167	532 40 52-57	Latch Brake Parking
17	532 19 72-96	Spring, Brake	170	532 19 43-22	Keeper V-Idler Center Span
26	532 19 96-79	Spring Return Cruise	171	872 11 06-16	Bolt RD HD SQNK 3/8-16 x 2
29	532 41 81-86	Rod, Brake	184	532 40 31-18	Handle Parking Brake
33	812 00 00-53	Ring E	186	532 19 43-21	Spacer Retainer
35	532 19 95-91	Rod, Brake, Park	187	819 13 32-10	Washer
42	532 12 48-72	Cover, Foot Pedal	188	532 19 43-23	Link Clutch Ground Drive
48	872 11 06-12	Bolt Carr Sh 3/8-16 x 1-1/2 Gr.5	189	532 40 75-04	Bellcrank Ground Drive
49	872 11 06-14	Bolt	190	532 40 75-05	Keeper Bellcrank Ground Drive
50	532 19 43-27	Pulley Idler Flat	196	817 00 06-16	Screw 3/8-16 x 1
51	873 90 06-00	Lock Nut 3/8-16	197	532 19 97-69	Bracket Clutch Anti-Rotation
52	532 19 43-26	Idler V-Groove 910" Offset	203	819 11 11-16	Washer 11/32 x 11/16 x 16 Ga.
56	532 42 08-07	V-Belt, Drive	206	532 19 78-67	Bracket Mount Latch Cruise
64	532 19 78-65	Shaft Asm. Pedal Brake Control	207	532 19 78-68	Latch Control Cruise
69	532 12 38-00	Washer 1-1/32 x 1-5/8 x 16 Ga.	208	532 19 78-69	Gear Sector Control Cruise
70	532 40 05-30	Console Asm	209	532 19 95-92	Rod Control Cruise
73	874 49 05-48	Bolt Hex 5/16-18 x 3 Gr. 5	210	532 19 78-60	Rocker Asm. Pedal Control
74	532 14 24-32	Screw 1/4 x 1/2	211	532 12 01-83	Bearing Nylon
80	532 41 81-84	Strap Torque	213	532 40 31-19	Knob Control Cruise
92	874 76 05-20	Bolt 5/16-18 x 1/2	214	532 41 68-63	Pedal Forward
99	532 41 81-88	Spring Bypass	215	532 40 17-23	Pedal Reverse
114	873 80 05-00	Nut Lock Hex W/Ins. 5/16-18 unc	220	532 19 89-08	Reflector RH
116	873 90 05-00	Nut Lock Hex Flange 5/16-18	221	532 40 31-87	Retainer Spring Clip Handle
121	532 17 56-11	Bracket Strap Torque	222	879 21 20-10	Washer 21/32 x 1-1/4 x 10 Ga.
125	817 00 05-12	Screw 5/16-18 x 3/4	286	872 01 05-20	Bolt 5/16-18 x 2.50
145	532 16 31-68	Washer Axle Flange	306	876 02 04-16	Pin Cotter 1/8 x 1
153	532 12 47-88	Retainer Spring			

**NOTE:** All component dimensions given in U.S. inches  
1 inch = 25.4 mm

**TRACTOR - MODEL NO. GTH26V48LS (96043009000), PRODUCT NO. 960 43 00-90  
ENGINE**

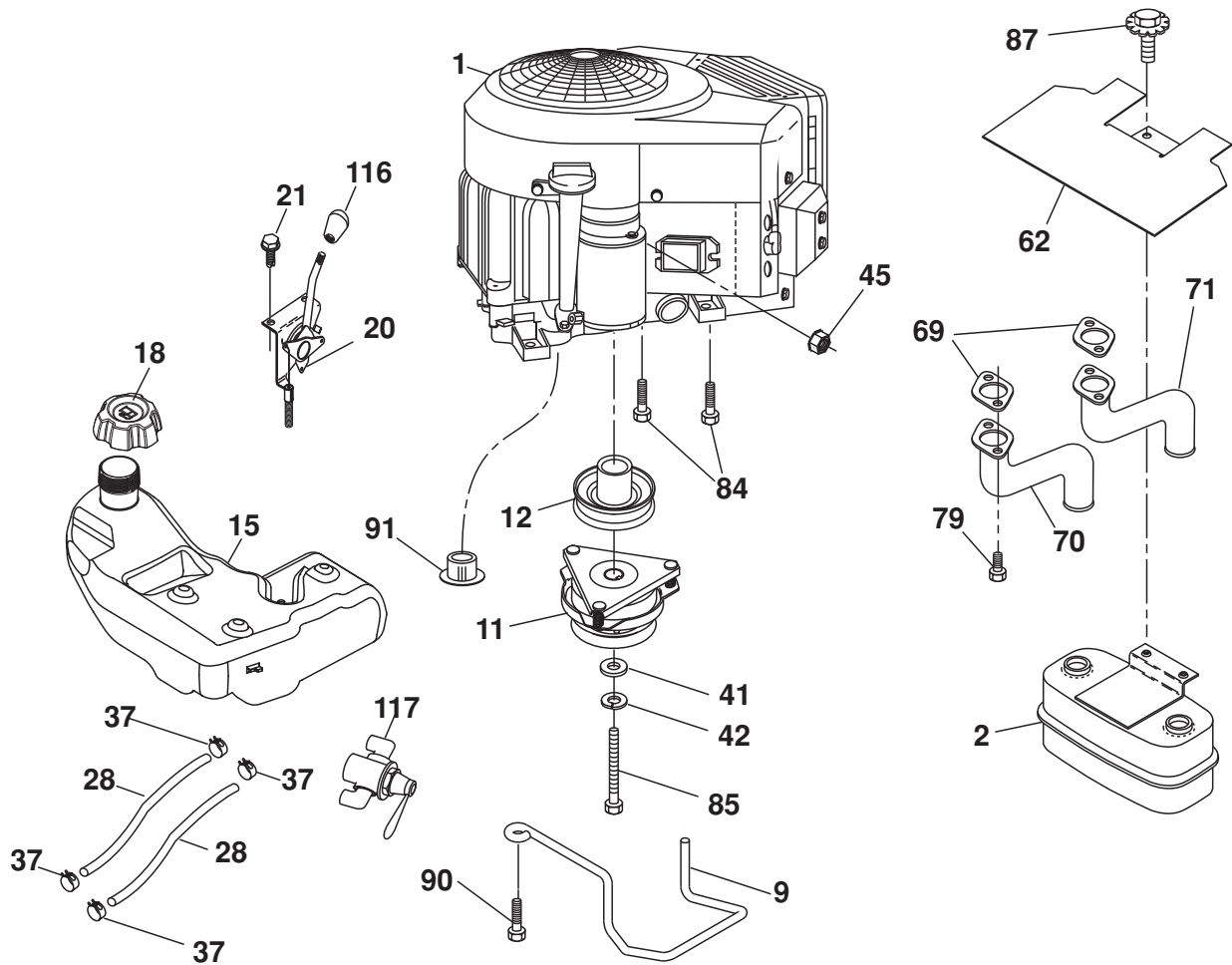

29

**SPARK ARRESTER KIT**

engine-tex\_bs-2cyl\_26

# TRACTOR - MODEL NO. GTH26V48LS (96043009000), PRODUCT NO. 960 43 00-90 ENGINE

KEY NO.	PART NO.	DESCRIPTION
1	-----	Engine B&S Model No. 44Q777
2	532 14 97-23	Muffler
9	532 40 86-67	Keeper Asm. Belt Engine
11	532 17 93-35	Clutch Electric
12	532 19 43-43	Pulley Engine
15	532 42 28-04	Tank Fuel 4R
18	532 19 42-67	Cap Asm
20	532 42 43-40	Control Throttle
21	532 41 63-58	Screw #10 x 0.750 BOS Thread
28	532 40 11-35	Fuel Line
29	532 13 71-80	Spark Arrester Kit
37	532 12 34-87	Clamp Hose
41	532 12 61-97	Washer 1-1/2 OD x 15/32 ID x .250
42	810 04 07-00	Washer Lock 7/16
45	873 51 04-00	Nut Keps Hex 1/4-20 unc
62	532 14 66-29	Shield Heat Muffler
69	532 16 53-91	Gasket
70	532 15 99-55	Tube Exhaust LH
71	532 16 05-89	Tube Exhaust RH
79	532 18 39-06	Screw Socket HD 5/16-18 x 1
84	817 06 06-20	Screw 3/8-16 x 1-1/4
85	532 17 99-53	Bolt 7/16-20 x 3.75 Gr. 5
87	532 19 82-39	Bolt 5/16-18 unc x 1 w/Sems
90	817 00 06-16	Screw 3/8-16 x 1
91	532 18 74-95	Bushing
116	532 42 46-59	Knob Soft Touch
117	532 42 08-28	Valve Fuel Reserve

**NOTE:** All component dimensions given in U.S. inches  
1 inch = 25.4 mm

For engine service and replacement parts, call the toll free number for your engine manufacturer listed below:

Briggs & Stratton            1-800-233-3723

## Engine Power Rating Information

The gross power rating for individual gas engine models is labeled in accordance with SAE (Society of Automotive Engineers) code J1940 (Small Engine Power & Torque Rating Procedure), and rating performance has been obtained and corrected in accordance with SAE J1995 (Revision 2002-05). Torque values are derived at 3060 RPM; horsepower values are derived at 3600 RPM. Actual gross engine power will be lower and is affected by, among other things, ambient operating conditions and engine-to-engine variability. Given both the wide array of products on which engines are placed and the variety of environmental issues applicable to operating the equipment, the gas engine will not develop the rated gross power when used in a given piece of power equipment (actual "on-site" or net power). This difference is due to a variety of factors including, but not limited to, accessories (air cleaner, exhaust, charging, cooling, carburetor, fuel pump, etc.), application limitations, ambient operating conditions (temperature, humidity, altitude), and engine-to-engine variability. Due to manufacturing and capacity limitations, Briggs & Stratton may substitute an engine of higher rated power for this Series engine.

**TRACTOR - MODEL NO. GTH26V48LS (96043009000), PRODUCT NO. 960 43 00-90**  
**STEERING ASSEMBLY**

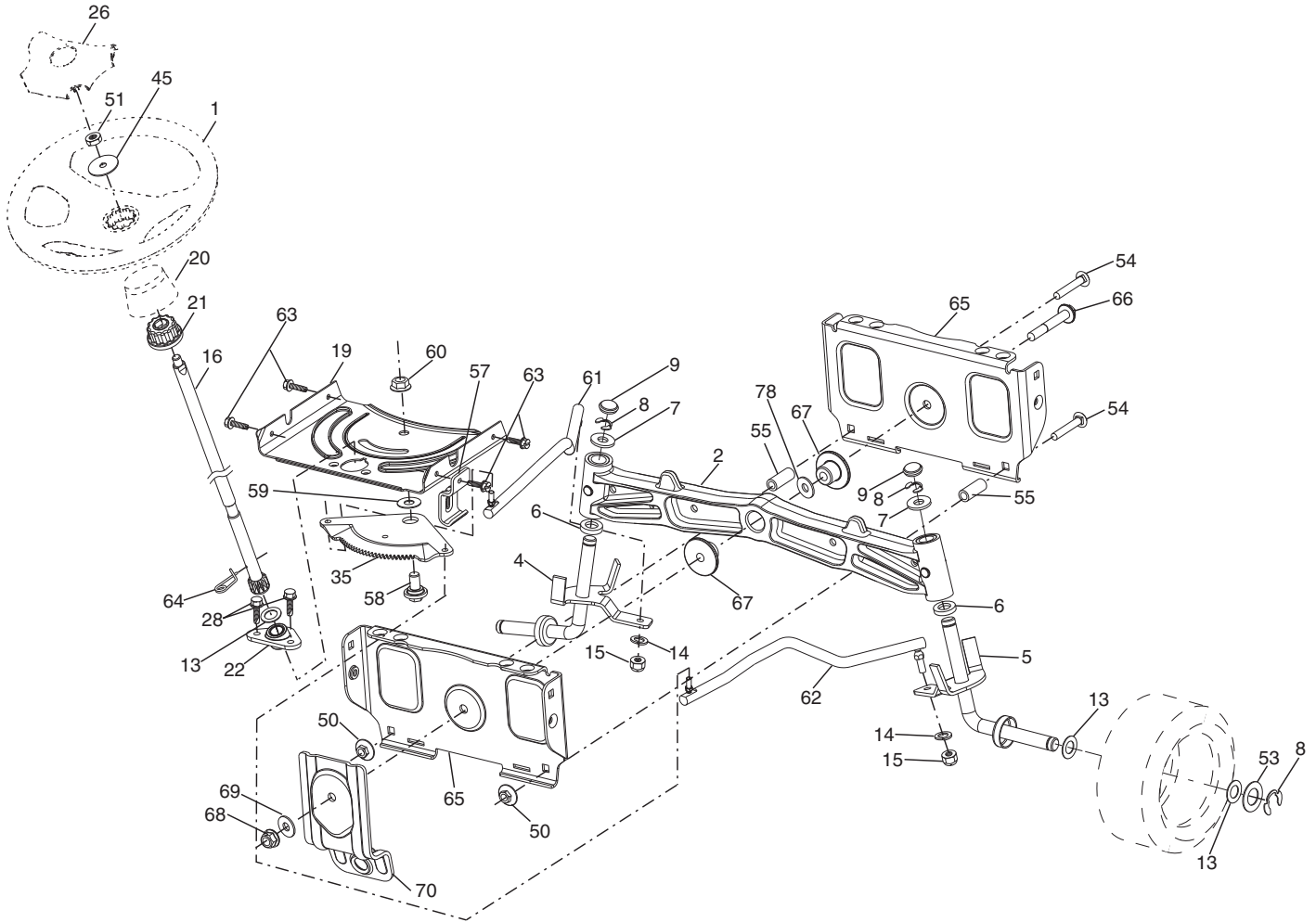

Steering-tex\_LEGND2\_33

**TRACTOR - MODEL NO. GTH26V48LS (96043009000), PRODUCT NO. 960 43 00-90  
STEERING ASSEMBLY**

<b>KEY NO.</b>	<b>PART NO.</b>	<b>DESCRIPTION</b>
1	532 41 64-80	Wheel, Steering
2	532 19 59-68	Axle Asm., Front
4	532 40 30-89	Spindle Asm. LH
5	532 40 30-90	Spindle Asm. RH
6	532 12 49-31	Bearing, Race Thrust Harden
7	532 12 17-48	Washer 25/32 x 1-5/8 x 16 Ga.
8	812 00 00-29	Ring, Clip #T5304-75
9	532 12 12-32	Cap, Spindle
13	532 12 17-49	Washer 25/32 x 1-1/4 x 16 Ga.
14	810 04 06-00	Washer, Lock Hvy Hlcl Spr 3/8
15	873 54 06-00	Nut, Crown Lock 3/8-24 unf
16	532 40 82-19	Shaft Steering
19	532 19 47-29	Plate Steering
21	532 18 67-37	Adapter, Wheel Steering
22	532 42 05-37	Steering Support Lower
26	532 41 59-87	Insert, Wheel Steering
28	817 00 06-12	Screw 3/8-16 x 3/4
35	532 19 47-32	Gear, Sector Plate
45	819 18 38-12	Washer 9/16 x 2-3/8 x 12 Ga.
50	873 90 06-00	Nut Lock Flange 3/8-16 unc
51	873 94 08-00	Nut Hex Jam Toplock 1/2-20 unf
53	532 18 89-67	Washer Hardened .793 x 1.637 x .060
54	874 76 06-36	Bolt Hex 3/8-16 unc x 2-1/4
55	532 41 47-36	Bolt Hex 3/8-16 unc x 2-1/4
57	532 19 72-46	Bracket Upstop
58	532 19 47-47	Bolt Shoulder Sector Pivot CFM
59	532 19 47-48	Washer Thrust Sector Steering
60	873 97 10-00	Nut Flange Lock 5/8-11
61	532 19 47-40	Draglink, LH
62	532 19 47-41	Draglink, RH
63	817 00 05-12	Screw 5/16-18 x 3/4
64	532 19 98-49	Retainer Clip Spring Steering
65	532 19 47-34	Brace Axle Front
66	871 02 07-48	Bolt Hex Fghd 7/16-14 x 3 Serr
67	532 19 47-37	Bushing PM Front Axle
68	873 90 07-00	Nut Lock Flange 7/16-14 Gr. 5
69	532 19 91-62	Washer 1.5 x .505 x .118
70	532 19 61-97	Bracket Deck Susp. Front
78	532 05 70-79	Washer Thrust

**NOTE:** All component dimensions given in U.S. inches  
1 inch = 25.4 mm

**TRACTOR - MODEL NO. GTH26V48LS (96043009000), PRODUCT NO. 960 43 00-90  
SEAT ASSEMBLY**

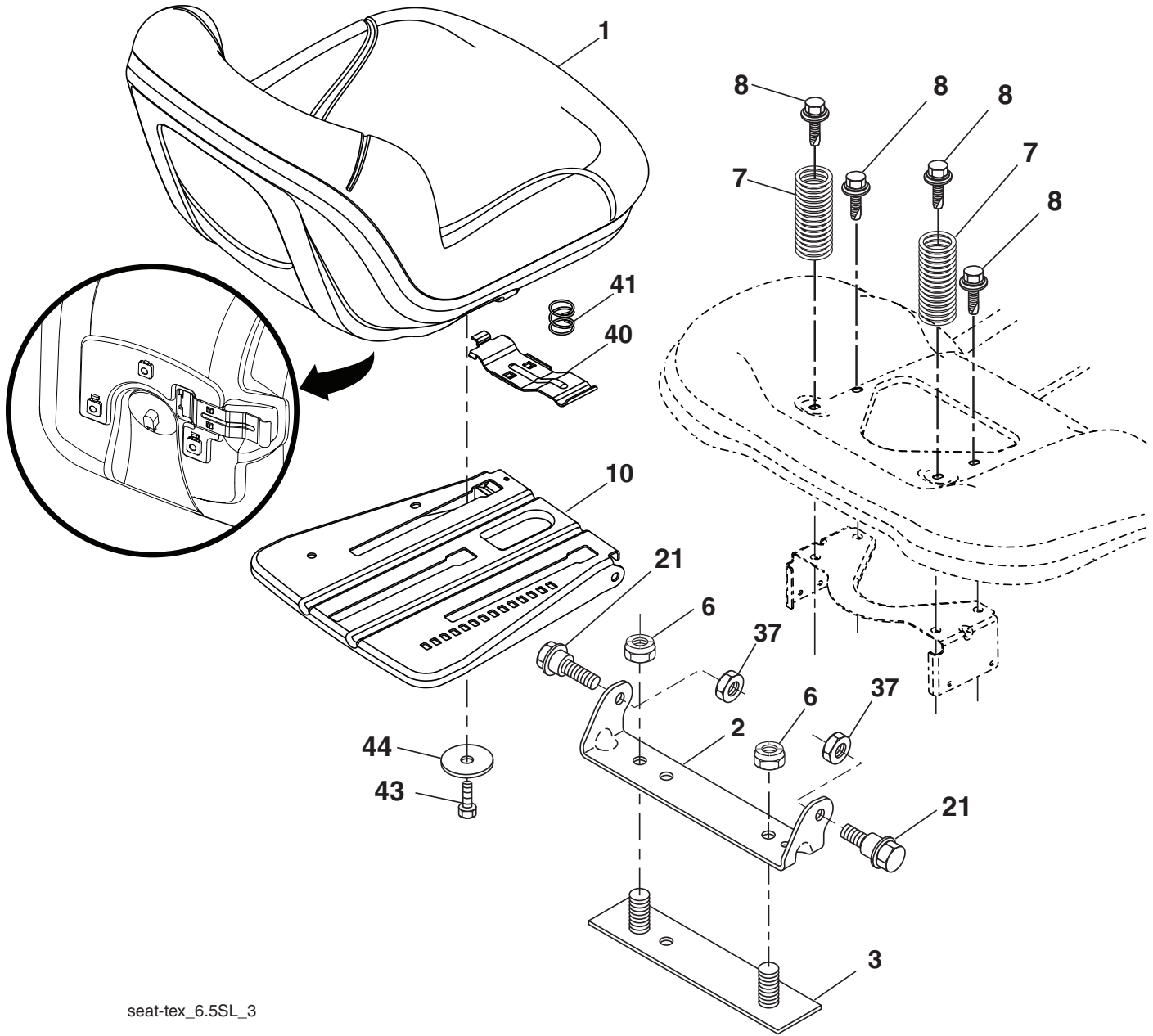

seat-tex\_6.5SL\_3

KEY NO.	PART NO.	DESCRIPTION
1	532 42 40-73	Seat
2	532 18 01-66	Bracket Pivot Fender
3	532 14 06-75	Strap, Asm Fender
6	873 80 06-00	Nut, Lock w/Ins. 3/8-16 unc
7	532 12 41-81	Spring, Seat Cprsn
8	532 17 18-77	Bolt 5/16-18 unc x 3/4 w/Sems
10	532 19 69-77	Pan, Seat
21	532 17 18-52	Bolt, Shoulder 5/16-18

KEY NO.	PART NO.	DESCRIPTION
37	873 80 05-00	Nut, Lock 5/16-18 unc
40	532 42 59-19	Handle Slide Seat
41	532 19 82-00	Spring Latch Seat
43	874 76 06-12	Bolt Fin Hex 3/8-16 unc x 3/4
44	819 13 38-12	Washer 13/32 x 2-3/8 x 12 Ga.

**NOTE:** All component dimensions given in U.S. inches  
1 inch = 25.4 mm

**TRACTOR - MODEL NO. GTH26V48LS (96043009000), PRODUCT NO. 960 43 00-90  
MOWER LIFT**

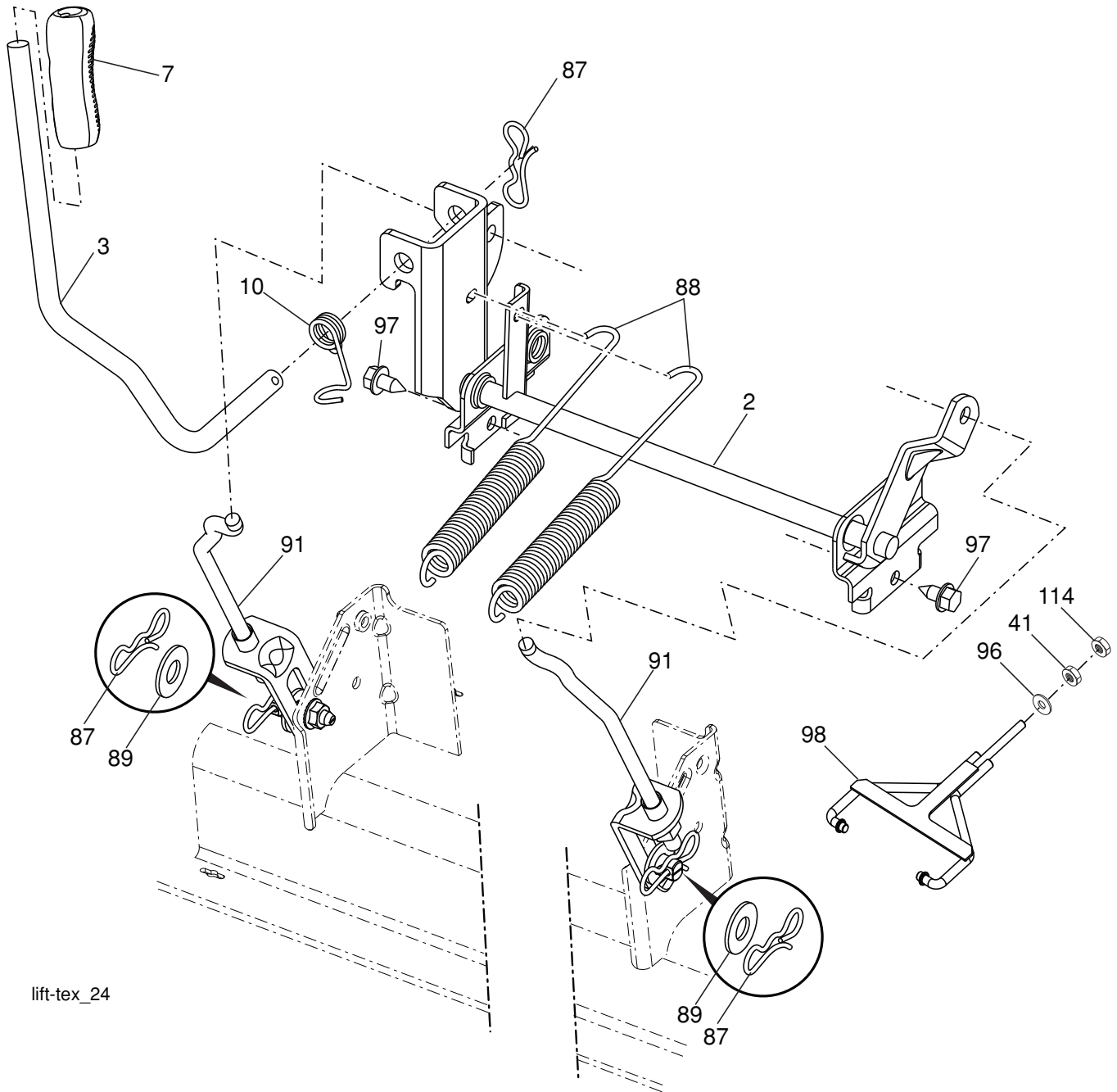

lift-tex\_24

KEY NO.	PART NO.	DESCRIPTION
2	532 42 20-27	Shaft Asm., Lift
3	532 19 52-30	Lever Asm., Lift RH
7	532 41 15-55	Grip, Lever
10	532 19 63-14	Spring Torsion
41	532 17 59-94	Nut Lift Link
87	532 19 42-09	Pin Cotter 7/16 Bow Tie Lock
88	532 19 53-04	Spring Lift Assist
89	819 19 19-12	Washer Clear Zinc

KEY NO.	PART NO.	DESCRIPTION
91	532 19 79-84	Link Lift Susp Mower Rear
96	532 19 52-63	Bushing Spherical
97	817 00 06-12	Screw 3/8-16 x .75
98	574 82 25-01	Link Lift Susp. Front Mower
114	873 36 07-00	Nut Jam 7/16-20

**NOTE:** All component dimensions given in U.S. inches  
1 inch = 25.4 mm

**TRACTOR - MODEL NO. GTH26V48LS (96043009000), PRODUCT NO. 960 43 00-90**  
**MOWER DECK**

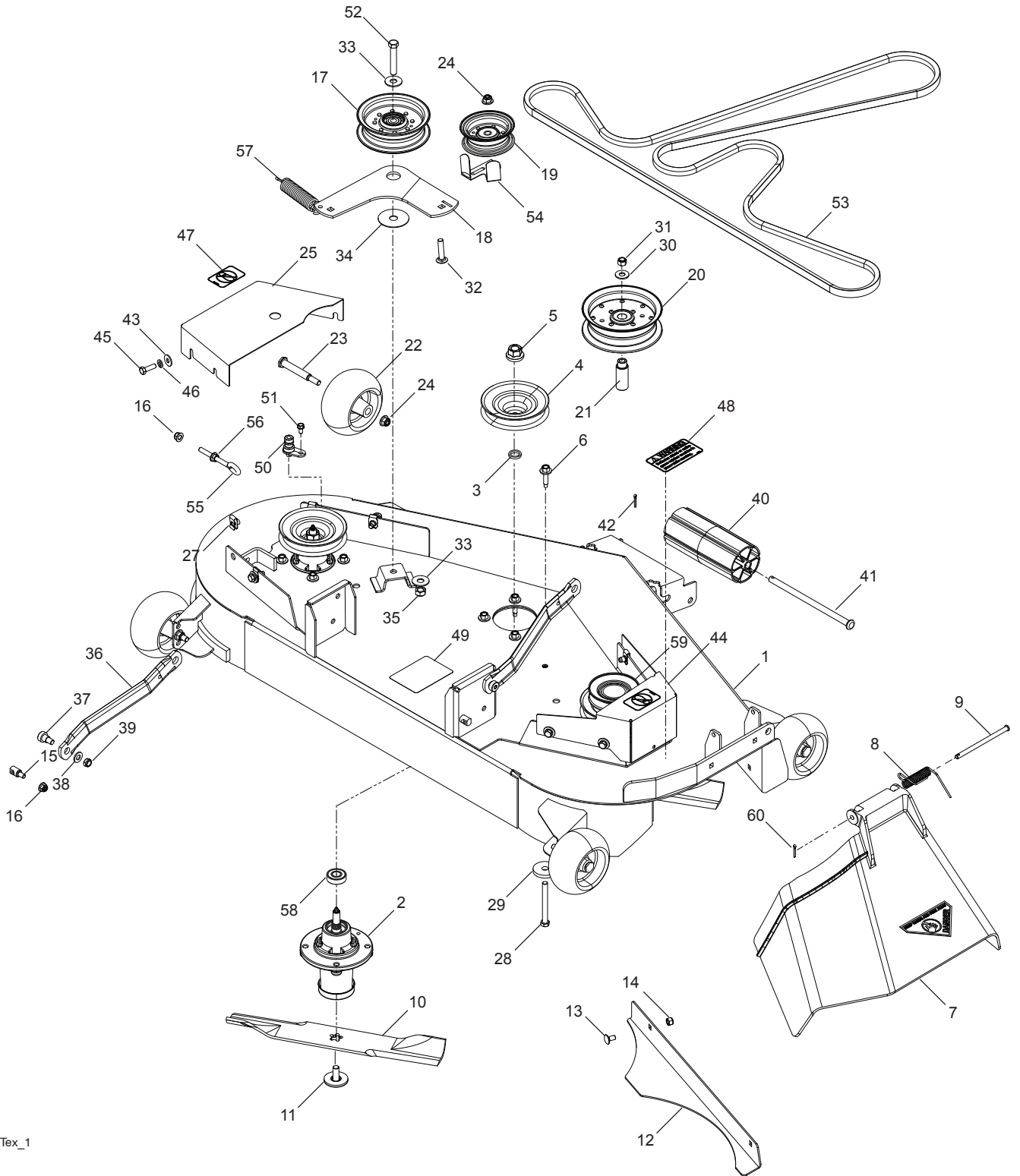

48\_F\_elec-Tex\_1



**TRACTOR - MODEL NO. GTH26V48LS (96043009000), PRODUCT NO. 960 43 00-90  
MOWER DECK**

KEY NO.	PART NO.	DESCRIPTION	KEY NO.	PART NO.	DESCRIPTION
1	575 43 80-02	Deck w/ Decals 48"	35	539 11 91-24	Nut, 7/16-14 Hex Nyloc
2	539 11 21-70	Housing Assembly	36	532 19 51-85	Arm, Susp., Rear
3	539 10 75-20	Washer-Spacer	37	539 11 36-21	Sb 3/8-16 x 3/8 Skt Hd
4	532 17 43-75	Pulley, Mandrel	38	539 99 01-22	Washer, 3/8 Sae Flt
5	539 10 75-90	Nut, 9/16 Top Center Lock	39	539 20 02-82	Nut, 3/8-16 Hex Jam Nyloc
6	539 10 76-30	Screw, Washer Head	40	532 17 60-66	Roller, Nose, 48"
7	532 11 07-32	Discharge Chute, 48"	41	532 17 91-27	Rod, Roller, Nose, Narrow
8	532 11 07-35	Spring - Torsion	42	532 19 42-08	Pin Cotter 5/16 Bow Tie Lock
9	532 11 07-36	Pin, Clevis 5/16 x 5.19	43	539 99 06-92	Washer, 5/16 Std Flt
10	539 11 34-25	Blade, 16-1/4"	44	575 50 39-02	Shield, Belt Rh
11	539 10 75-22	Bolt, 7/16, Assy Blade	45	539 99 02-09	Hcs 5/16-18 x 1 Gr 5
12	539 11 34-27	Confinement Plate	46	539 99 01-87	Wash 5/16 Slw
13	539 99 07-99	Rhsnb 5/16-18 x 5/8 Gr 5	47	539 10 57-43	Decal, No Step
14	539 99 07-17	Nut 5/16-18 Hex Nyloc	48	539 11 32-24	Decal, Warning
15	532 19 51-61	Stud, Fasten w/ Anti- Rotate	49	532 19 87-85	Decal, Deck Sch
16	539 11 28-99	Nut 5/16-18 Hex Flange Nyloc	50	532 41 55-98	Washout Port
17	532 19 61-04	Pulley, Idler Spec. Hub	51	539 10 84-61	Bolt, 1/4-20 x 1/2
18	574 82 71-02	Arm, Idler, Blk	52	539 10 48-70	Hcs 7/16-14 x 2-1/2 Gr 5
19	532 17 79-68	Pulley, Idler	53	574 84 56-02	Belt, Deck
20	539 13 27-28	Pulley, Idler	54	575 22 43-01	Guard, Belt
21	575 22 45-01	Idler Bushing	55	539 11 55-74	Eyebolt 5/16 x 3-1/2
22	539 10 76-10	Wheel, Gauge	56	539 99 05-85	Nut 5/16-18 Hex Whizlk
23	539 10 76-08	Bolt, Shoulder	57	539 10 68-50	Spring
24	521 99 65-01	Nut 3/8-16 Hex Flg Nyloc	58	539 11 20-50	Ball Bearing
25	575 22 47-02	Shield, Belt LH	59	575 35 29-01	Pulley
27	539 10 47-63	Retainer 5/16c U Type	60	532 16 94-84	Clip Retainer
28	539 10 82-71	Hcs 3/8-16 x 3-1/2 Gr 5	--	575 01 58-02	Mower Deck Complete
29	539 10 65-04	Heavy Washer			
30	539 99 05-17	Washer, 3/8 Flat Std			
31	539 97 69-79	Nut 3/8-16 Hex Nyloc			
32	539 99 09-23	Rhsnb 3/8-16 x 1-3/4 Gr 5			
33	539 10 48-64	Washer, 7/16 Flat			
34	532 17 85-15	Washer, Flat Hardened			

**NOTE:** All component dimensions given in U.S. inches  
1 inch = 25.4 mm

