

# **Operator's manual**

# **EZ22**

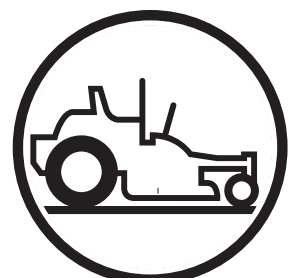

Please read these instructions carefully and make sure you understand them before using the machine.

**English**

**In order to implement improvements, specifications and designs can be altered without prior notification.**

**Note that no legal demands can be placed based on the information contained in these instructions.**

**Use only original parts for repairs. The use of other parts voids the warranty.**

**Do not modify or install non-standard equipment to the unit without consent from the manufacturer. Modifications to the unit may cause unsafe operations or damage the unit.**

---

# CONTENTS

---

INTRODUCTION.....	5	MAINTENANCE.....	34
Driving and Transport on Public Roads.....	5	Maintenance Schedule.....	34
Towing.....	5	Battery.....	36
Operating.....	5	Ignition System.....	37
Good Service.....	6	Safety System.....	37
SYMBOLS AND DECALS.....	7	Engine Cooling Air Intake.....	38
Safety Instructions.....	9	Throttle Cable.....	38
SAFETY.....	9	Choke Cable.....	38
Personal Safety Equipment.....	11	Air Filter.....	39
Slope Operation.....	11	Fuel Filter.....	40
Children.....	12	Tire Pressures.....	41
Safe Handling of Gasoline.....	13	Parking Brake.....	41
General Maintenance.....	14	V-belts.....	42
Transport.....	16	Deck Belt Removal.....	42
Control Locations.....	17	Pump Belt.....	43
CONTROLS.....	17	Cutting Blades.....	44
Steering Control Levers.....	18	Blade replacement.....	44
Parking Brake.....	19	Adjusting the Mower Deck.....	45
Throttle Control.....	19	Leveling deck.....	45
Blade Switch.....	19	Anti-scalp rollers.....	46
Ignition Switch.....	20	Cleaning.....	47
Choke Control.....	20	Caster Wheels.....	47
Fuses.....	20	Hardware.....	47
Fuel Tank.....	21	LUBRICATION.....	48
Fuel Shut Off Valve.....	22	Front Wheel Mount.....	49
Cutting Height Adjuster.....	22	Front Wheel Bearings.....	49
Hour Meter.....	23	Deck Spindle.....	49
Tracking Knob.....	23	Deck Outer Spindle.....	49
OPERATION.....	24	Engine Oil.....	50
Training.....	24	Transaxle (Transmission) Fluid Change.....	52
Steering.....	24	Purging.....	53
Before Starting.....	25	TROUBLESHOOTING.....	54
Starting the Engine.....	25	STORAGE.....	56
Weak Battery.....	28	Winter Storage.....	56
Jumper Cables.....	28	Service.....	56
Running.....	29	SCHEMATICS.....	57
Operating On Hills.....	30	TECHNICAL DATA.....	58
Mowing Tips.....	31	Accessories.....	60
Stopping the Engine.....	32	Torque Specifications.....	60
Manual Transport.....	33	CONFORMITY CERTIFICATES.....	61
		SERVICE JOURNAL.....	62

---

# INTRODUCTION

---



**WARNING!**

Failure to follow cautious operating practices can result in serious injury to the operator or other persons. The owner must understand these instructions, and must allow only trained persons who understand these instructions to operate the mower.

Each person operating the mower must be of sound mind and body and must not be under the influence of any mind altering substance.

---

# INTRODUCTION

---

## **Congratulations**

Thank you for purchasing a Husqvarna ride-on mower. This machine is built for superior efficiency to rapidly mow primarily large areas. A control panel easily accessible to the operator and a hydrostatic transmission regulated by steering controls both contribute to the machine's performance.

This manual is a valuable document. Read the contents carefully before using or servicing the machine. The following of instructions (use, service, maintenance) by all who operate this machine is important for the safety of the operator and others. It can also considerably increase the life span of the machine and increase its resale value.

If you sell your machine, be sure to give the operator's manual to the new owner.

The final chapter of this operator's manual provides a Service Journal. Ensure that service and repair work are documented. A well-kept service journal reduces service costs for the maintenance and affects the machine's resale value. Please contact your dealer for more information. Take the operator's manual along when the machine is taken to your dealer for service.

## **General**

In this operator's manual, left and right, backward and forward are used in relation to the machine's normal driving direction.

Continuous dedication to improve our products require that specifications and design are subject to change without notice.

## **Driving and Transport on Public Roads**

Check applicable road traffic regulations before transporting on public roads. If the machine is transported, you must always use approved fastening equipment and ensure that the machine is well anchored. DO NOT operate this machine on public roadways.

## **Towing**

If machine is equipped with a tow hitch, use extreme caution when towing. Never allow children or others in or on the towed equipment. Make wide turns to avoid jack-knifing. Travel slowly and allow extra distance to stop.

Do not tow on sloped ground. The weight of the towed equipment may cause loss of traction and loss of control.

Follow the manufacturer's recommendation for weight limits for towed equipment. Do not tow near ditches, canals, and other hazards.

## **Operating**

This machine is constructed only for mowing grass on lawns and even ground without obstacles such as stones, tree stumps, etc. The machine can also be used for other tasks when equipped with special accessories provided by the manufacturer. Operating instructions for the accessories are provided with delivery. All other types of uses are incorrect. The manufacturer's directions concerning operation, maintenance, and repairs must be carefully followed.

Lawn mowers and all power equipment, can be potentially dangerous if used improperly. Safety requires good judgement, careful use in accordance with these instructions and common sense.

The machine must only be operated, maintained, and repaired by persons familiar with the machine's special characteristics and who are also knowledgeable about the safety instructions. Use only approved repair parts to maintain this machine.

Accident prevention regulations, other general safety regulations, occupational safety rules, and traffic regulations must be followed without fail.

Unauthorized modifications to the design of the machine may absolve the manufacturer from liability for any resulting personal injury or property damage.

---

# INTRODUCTION

---

## Good Service

Husqvarna's products are sold all over the world and only in specialized retail stores with complete service. This ensures that you as a customer receive only the best support and service. Before the product is delivered, the machine has, for example, been inspected and adjusted by your retailer. See the certificate in the Service Journal in this operator's manual.

When you need spare parts or support in service questions, warranty issues, etc., please consult the following professional:

This Operator's Manual belongs to the machine with the manufacturing number:	Engine	Transmission

## Manufacturing Number

The machine's manufacturing number can be found on the printed plate affixed to the right in the engine compartment. Stated on the plate, from the top are:

The machine's type designation (I.D.).

The manufacturer's type number (Model).

The machine's serial number (Serial no.)

*Please have the type designation and serial number available when ordering spare parts.*

The engine's manufacturing number is stamped on one of the valve covers.

The plate states:

The engine's model.

The engine's type.

Code

*Please have these available when ordering spare parts.*

The wheel motors and hydrostatic pumps have a barcode decal affixed at the rear.

# SYMBOLS AND DECALS

These symbols are found on the machine and in the operator's manual. Study them carefully so that you know what they mean.

**WARNING!**

Xxxx xxxxxxx xxxxx xxxx  
 xxxxxxxxxxx xxxxxx xxxxxxxxxxx. xx  
 xxxxxxxxxxx xxxx xxxxxxx.

Used in this publication to notify the reader of a risk of **personal injury or death**, particularly if the reader should neglect to follow instructions given in the manual.

**IMPORTANT INFORMATION**

Xxxx xxxxxx xxxxx xxxx xxxxxxxxxxx xxxxxx  
 xxxxxxxxxxx. xx xxxxxxxxxxx xxxx xxxxxxx.

Used in this publication to notify the reader of a risk of **material damage**, particularly if the reader should neglect to follow instructions given in the manual. Used also when there is a potential for misuse or misassembly.



Reverse



Neutral



Fast



Slow

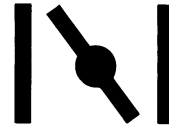

Choke



Fuel



Warning!



Parking Brake



CE conformity marking. Only for European market

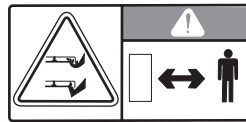

Warning! Rotating blades, keep away from the discharge deck

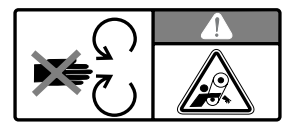

Do not touch parts



Battery acid is corrosive, explosive and flammable



Do not stand here



Noise emissions to the surroundings in accordance with the European Union's directive. The machine's emission is stated in the chapter TECHNICAL DATA and on the decals. Only machines for European market

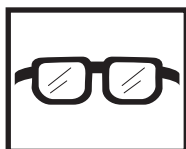

Use protective glasses



Use protective gloves

# SYMBOLS AND DECALS

Read  
Operator's  
Manual

Shut off engine and  
remove key before  
performing any  
maintenance or repair work

Keep a safe  
distance from  
the machine

Use on slopes  
no greater  
than 10°

No passengers

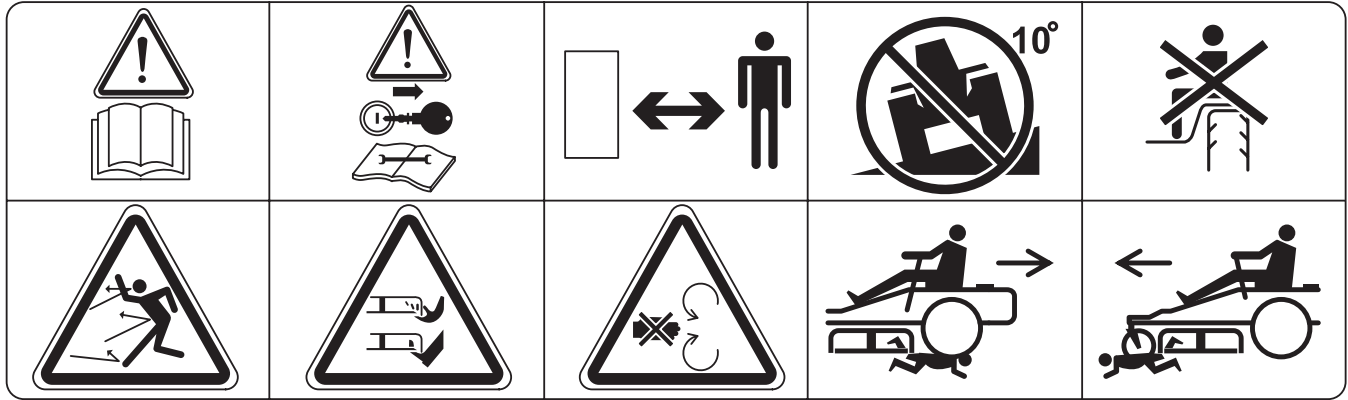

Whole body  
exposure to  
thrown objects

Severing of fingers  
and toes

Do not open or  
remove safety  
shields while  
engine is running

Careful backing up,  
watch for other  
people

Careful going  
forward, watch for  
other people



Moving sharp blades under cover



# SAFETY

## Safety Instructions

These instructions are for your safety. Read them carefully.



### WARNING!

This symbol means that important safety instructions need to be emphasized. It concerns your safety.

**IMPORTANT:** THIS CUTTING MACHINE IS CAPABLE OF AMPUTATING HANDS AND FEET AND THROWING OBJECTS. FAILURE TO OBSERVE THE FOLLOWING SAFETY INSTRUCTIONS COULD RESULT IN SERIOUS INJURY OR DEATH.

### General Operation

- Read, understand, and follow all instructions on the machine and in the manual before starting.
- Do not put hands or feet near rotating parts or under the machine. Keep clear of the discharge opening at all times.
- Only allow responsible adults, who are familiar with the instructions, to operate the machine.
- Clear the area of objects such as rocks, toys, wire, etc., which could be picked up and thrown by the blades.
- Be sure the area is clear of bystanders before operating. Stop machine if anyone enters the area.
- Never carry passengers. The machine is only intended for use by one person.
- Do not mow in reverse unless absolutely necessary. Always look down and behind before and while backing.
- Never direct discharged material toward anyone. Avoid discharging material against a wall or obstruction. Material may ricochet back toward the operator. Stop the blades when crossing gravel surfaces.
- Do not operate machine without the entire grass catcher, discharge guard, or other safety devices in place and working
- Slow down before turning.
- Never leave a running machine unattended. Always turn off blades, set parking brake, stop engine, and remove keys before dismounting.
- Disengage blades when not mowing. Shut off engine, remove keys and wait for all parts to come to a complete stop before cleaning the machine, removing the grass catcher, or unclogging the discharge guard.
- Operate machine only in daylight or good artificial light.
- Do not operate the machine while under the influence of alcohol or drugs.

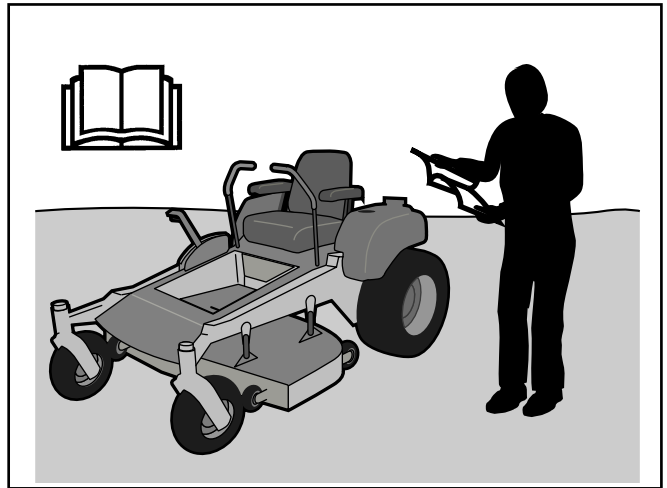

8011-512

*Read the operator's manual before starting the machine*

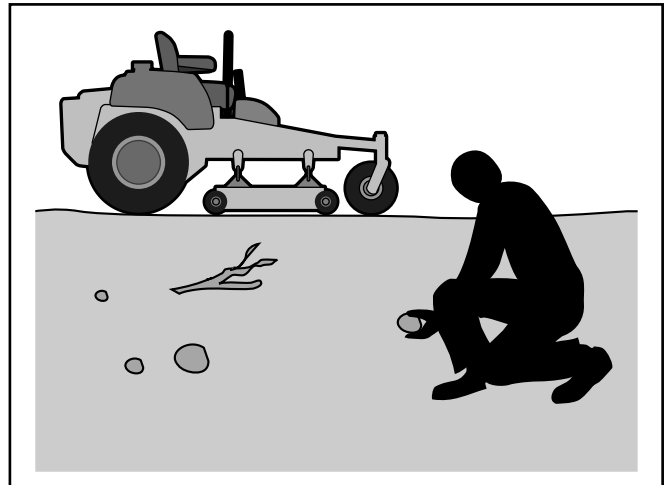

8011-513

*Clear the area of objects before mowing*

# SAFETY

- Watch for traffic when operating near or crossing roadways.
- Use extra care when loading or unloading the machine into a trailer or truck.
- Always wear eye protection when operating machine.
- Follow the manufacturer's recommendation for wheel weights or counterweights.
- Anyone who operates this machine must first read and understand this Operation Manual. Local laws may regulate the age of the user.
- Keep machine free of grass, leaves or other debris buildup which can touch the hot exhaust or engine parts and burn. Do not allow the mower deck to plow leaves or other debris, causing buildup to occur.
- Clean any oil or fuel spillage before operating or storing the machine.
- Allow machine to cool before storage.



8011-520

*Never take passengers*



## WARNING!

This mower is equipped with an internal combustion engine and should not be used on or near any unimproved forested, bush covered or grassy lands unless the engine's system is equipped with a spark arrester meeting applicable local or state laws (if any). If a spark arrester is used, it should be maintained in effective working order by the operator.



## WARNING!

Engine exhaust and certain vehicle components contain or emit chemicals considered to cause cancer, birth defects, or other reproductive system damage. The engine exhaust contains carbon monoxide, which is an odorless, colorless, poisonous gas. Do not use the machine in enclosed spaces.

# SAFETY

## Personal Safety Equipment



### WARNING!

When using the machine, approved personal protective equipment (shown in illustrations) shall be used. Personal protective equipment cannot eliminate the risk of injury but it will reduce the degree of injury if an accident does happen. Ask your retailer for help in choosing the right equipment.

- Make sure that you have first aid equipment close at hand when using the machine.
- Never use the machine when barefoot.
- Always wear protective shoes or boots, preferably with steel toe caps.
- Always wear approved protective glasses or a full visor when assembling or driving.
- Always wear gloves when handling the blades.
- Never wear loose clothing that can get caught in moving parts.
- Use ear protectors to avoid damage to hearing.

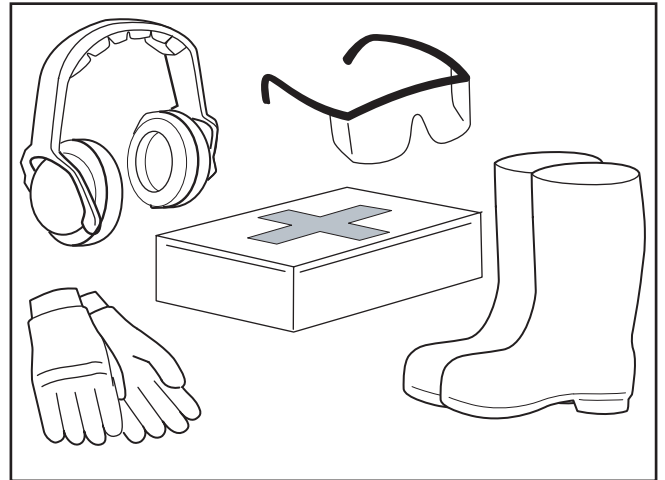

8011-670a

Personal protective equipment

## Slope Operation

Slopes are a major factor related to loss of control and tip-over accidents, which can result in severe injury or death. Operation on all slopes requires extra caution. If you cannot back up the slope or if you feel uneasy on it, do not mow it.

- Mow up and down slopes (10 degrees maximum), not across.
- Watch for holes, ruts, bumps, rocks, or other hidden objects. Uneven terrain could overturn the machine. Tall grass can hide obstacles.
- Choose a low ground speed so that you will not have to stop while on the slope.
- Do not mow on wet grass. Tires may lose traction.
- Avoid starting, stopping, or turning on a slope. If the tires lose traction, disengage the blades and proceed slowly straight down the slope.
- Keep movement on the slopes slow and gradual. Do not make sudden changes in speed or direction, which could cause machine to roll over.
- Use extra care while operating machine with grass catchers or other attachments; they can affect the stability of the machine.
- Do not use on steep slopes.
- Do not try to stabilize the machine by putting a foot on the ground.
- Do not mow near drop-offs, ditches, or embankments. The machine could suddenly roll over if a wheel is over the edge or if the edge caves in.

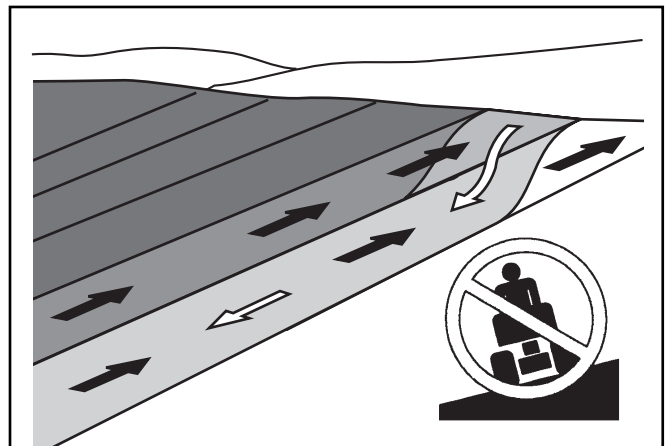

6003-004

Mow up and down, not side to side



### WARNING!

Do not drive up or down hills with slopes greater than 10 degrees. And do not drive across any slopes.

# SAFETY

## Children

Tragic accidents can occur if the operator is not alert to the presence of children. Children are often attracted to the machine and the mowing activity. *Never* assume that children will remain where you last saw them.

- Keep children out of the mowing area and in the watchful care of a responsible adult other than the operator.
- Be alert and turn machine off if a child enters the area.
- Before and while backing, look behind and down for small children.
- Never carry children, even with the blades shut off. They may fall off and be seriously injured or interfere with safe machine operation. Children who have been given rides in the past may suddenly appear in the mowing area for another ride and be run over or backed over by the machine.
- Never allow children to operate the machine.
- Use extra care when approaching blind corners, shrubs, trees, or other objects that may block your view of a child.



8011-509

*Be extra cautious when driving on slopes*

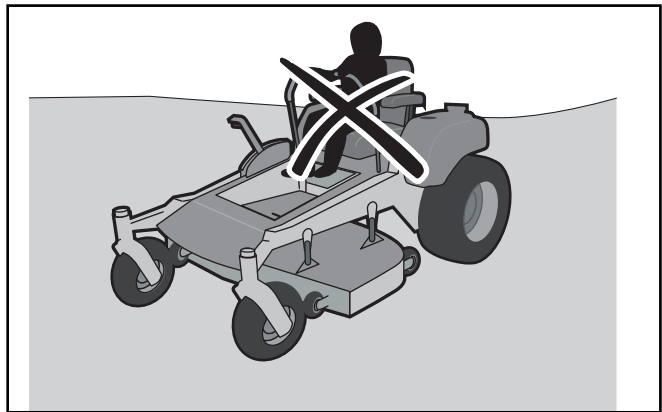

8011-517

*Never allow children to operate the machine*



8011-518

*Keep children away from work area*

# SAFETY



## WARNING!

The engine must not be started when the driver's floor plate or any protective plate for the mower deck's drive belt is removed.

## Safe Handling of Gasoline

To avoid personal injury or property damage, use extreme care in handling gasoline. Gasoline is extremely flammable and the vapors are explosive.

- Extinguish all cigarettes, cigars, pipes, and other sources of ignition.
- Use only approved gasoline container.
- Never remove gas cap or add fuel with the engine running. Allow engine to cool at least two (2) minutes before refueling.
- Never fuel the machine indoors.
- Never store the machine or fuel container where there is an open flame, spark, or pilot light such as on a water heater or other appliance.
- Before you begin refueling, minimize the risk of static electricity by touching a metal surface.
- Never fill containers inside a vehicle or on a truck or trailer bed with plastic liner. Always place containers on the ground away from the vehicle when filling.
- Remove gas-powered equipment from the truck or trailer and refuel it on the ground. If this is not possible, refuel such equipment with a portable container, rather than from a gasoline dispenser nozzle.
- Keep the nozzle in contact with the rim of the fuel tank or container opening at all times until fueling is complete. Do not use a nozzle lock-open device.
- If fuel is spilled on clothing, change clothing immediately.
- Never overfill fuel tank. Replace gas cap and tighten securely.
- Do not start the engine near spilled fuel.
- Never use gasoline as a cleaning agent.
- If leaks arise in fuel system, engine must not be started until problem has been resolved.
- Check the fuel level before each use and leave space for the fuel to expand, as the heat from the engine and the sun may otherwise cause the fuel to expand and overflow.

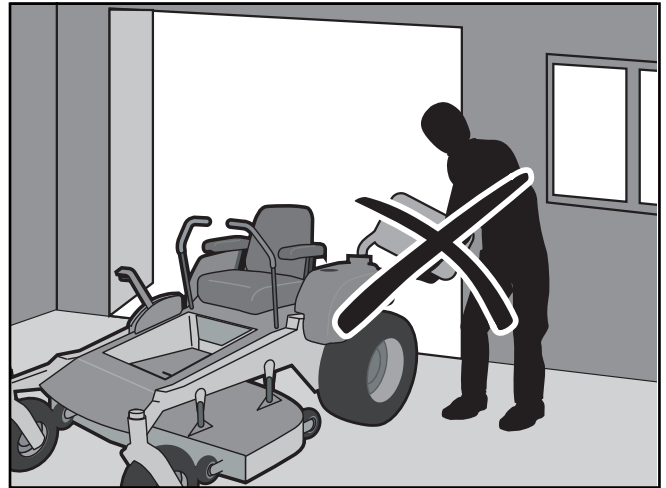

Never fill the fuel tank indoors

8011-516



## WARNING!

The engine and the exhaust system become very hot during operation.

There is risk for burns if touched.

Allow engine and exhaust system to cool at least two (2) minutes before refueling.

# SAFETY

## General Maintenance

- Never operate machine in a closed area.
- Keep all nuts and bolts tight to be sure the equipment is in safe working condition.
- Never tamper with safety devices. Check their proper operation regularly.
- Keep machine free of grass, leaves, or other debris buildup. Clean oil or fuel spillage and remove any fuel-soaked debris. Allow machine to cool before storing.
- If you strike a foreign object, stop and inspect the machine. Repair, if necessary, before restarting.
- Never make any adjustments or repairs with the engine running.
- Check grass catcher components and the discharge guard frequently and replace with manufacturer's recommended parts, when necessary.
- Mower blades are sharp. Wrap the blade or wear gloves, and use extra caution when servicing them.
- Check brake operation frequently. Adjust and service as required.
- Maintain or replace safety and instruction labels, as necessary.
- Do not modify safety equipment. Check regularly to be sure it works properly. The machine must not be driven with defective or unmounted protective plates, protective cowlings, safety switches, or other protective devices.
- Do not change the settings of governors and avoid running the engine with overly high engine speeds. If you run the engine too fast, you risk damaging the machine components.
- Be very careful when handling battery acid. Acid on skin can cause serious corrosive burns. If you spill battery acid on your skin, rinse immediately with water.
- Acid in the eyes can cause blindness, contact a doctor immediately.
- Be careful when servicing the battery. Explosive gases form in the battery. Never perform maintenance on the battery when smoking or near open flames or sparks.
- The battery can explode and cause serious injury/ damage.
- Ensure that nuts and bolts, especially the fastening bolts for the blade attachments, are properly tightened, torqued and that the equipment is in good condition.

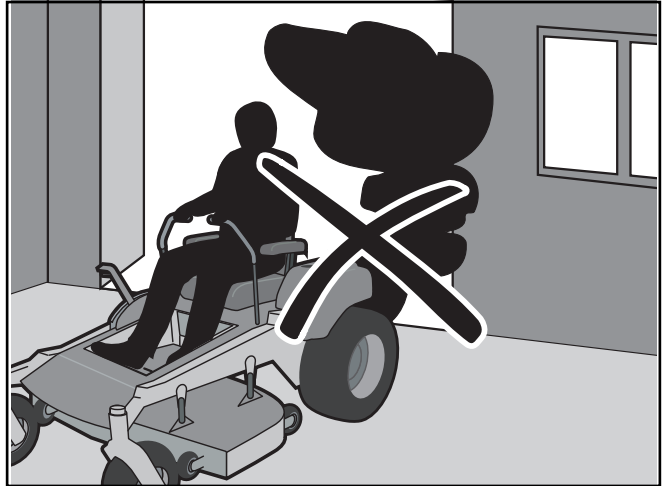

Never drive the machine in an enclosed space

8011-515



### WARNING!

Use protective glasses for maintenance work.



### WARNING!

The battery contains lead and lead compounds, chemicals that are considered to cause cancer, birth defects, and other reproductive system damage. Wash your hands after handling the battery.

# SAFETY

- Sparking can occur when working with the battery and the heavy cables of the starter circuit. This can cause battery explosion, fire or eye injury. Sparking in this circuit can not occur after the chassis cable (normally negative, black) is removed from the battery.



## WARNING!

**Avoid electrical sparking and its consequences by the following routines:**

- Use protective goggles.
- Ensure that the fuel filler cap is mounted tightly and no flammable substances are stored in an open vessel.
- Never work with the starter circuit if there is spilled fuel.
- Disconnect the chassis cable from the battery first and reconnect it last.
- Do not make a bridge short circuit across the starter relay to run the starter.
- Never use the machine indoors or in spaces lacking proper ventilation. The exhaust fumes contain carbon monoxide, an odorless, poisonous, and lethal gas.
- Stop and inspect the equipment if you run over or into anything. If necessary, make repairs before starting.
- Never make adjustments with the engine running.
- The machine is tested and approved only with the equipment originally provided or recommended by the manufacturer. Only use approved repair parts for the machine.
- The blades are sharp and can cause cuts and gashes. Wrap the blades or use protective gloves when handling them.
- Check the parking brake's functionality regularly. Adjust and service as necessary.
- The mulch blades should only be used in familiar areas when higher quality mowing is desired.
- Reduce the risk of fire by removing grass, leaves, and other debris that may have accumulated on the machine. Allow the machine to cool before putting it in storage.
- Regularly clean deck and underside of deck, avoid spraying engine and electrical components with water.

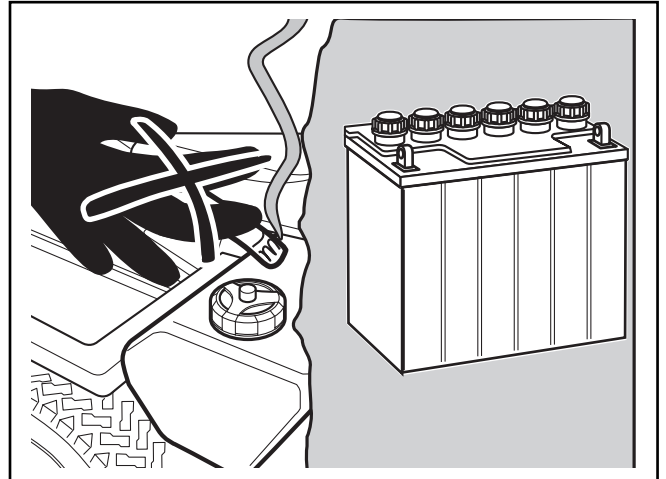

6003-009

*Do not smoke when performing maintenance on the battery. The battery can explode and cause serious injury/damage.*

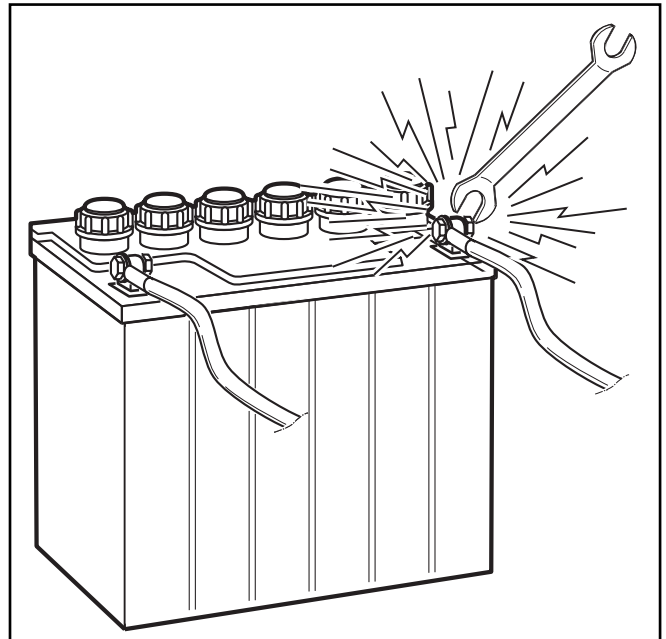

8009-728

*Risk of sparking*

# SAFETY

## Transport

- The machine is heavy and can cause serious crushing injuries. Be extra cautious when it is loaded on or unloaded from a vehicle or trailer.
- Use an approved trailer to transport the machine. Activate the parking brake, turn off the fuel supply, and fasten the machine with approved fastening devices, such as bands, chains, or straps, when transporting.
- Do not operate this machine on public roadways.
- Check and abide by local traffic regulations before transporting the machine on any road.
- Do not tow this machine, it may cause damage to the drive system.
- Do not tow with this mower unless it is equipped with a tow hitch. Carefully read the towing cautions in the Introduction section of this manual.
- Load the unit onto truck or trailer by driving up ramps of suitable strength using a slow speed. Do not lift! The machine is not intended to be lifted by hand.

### IMPORTANT INFORMATION

**The parking brake is not sufficient to lock the machine in place during transport. Ensure that the machine is well fastened to the transport vehicle. Always reverse the machine onto the transport vehicle to avoid tipping it over.**

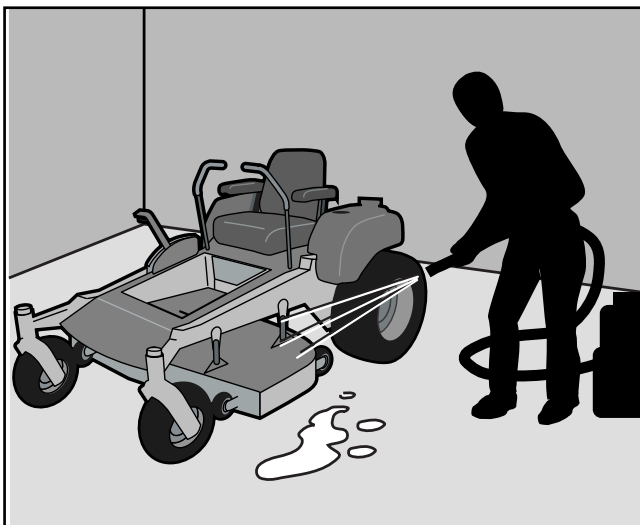

*Regularly clean deck*

8011-514



### WARNING!

**Escaping hydraulic oil under pressure can have sufficient force to penetrate the skin, causing serious injury. If injured by escaping fluid, see a doctor at once. Serious infection or reaction can develop if proper medical treatment is not administered immediately.**



# CONTROLS

This operator's manual describes the Husqvarna Zero Turn Rider. The rider is fitted a Briggs & Stratton four-stroke overhead valve engine developing 22 horse power\*.

Transmission from the engine is made via a belt-driven hydraulic pumps. Using the left and right steering controls, the flow is regulated and thereby the direction and speed.

## Control Locations

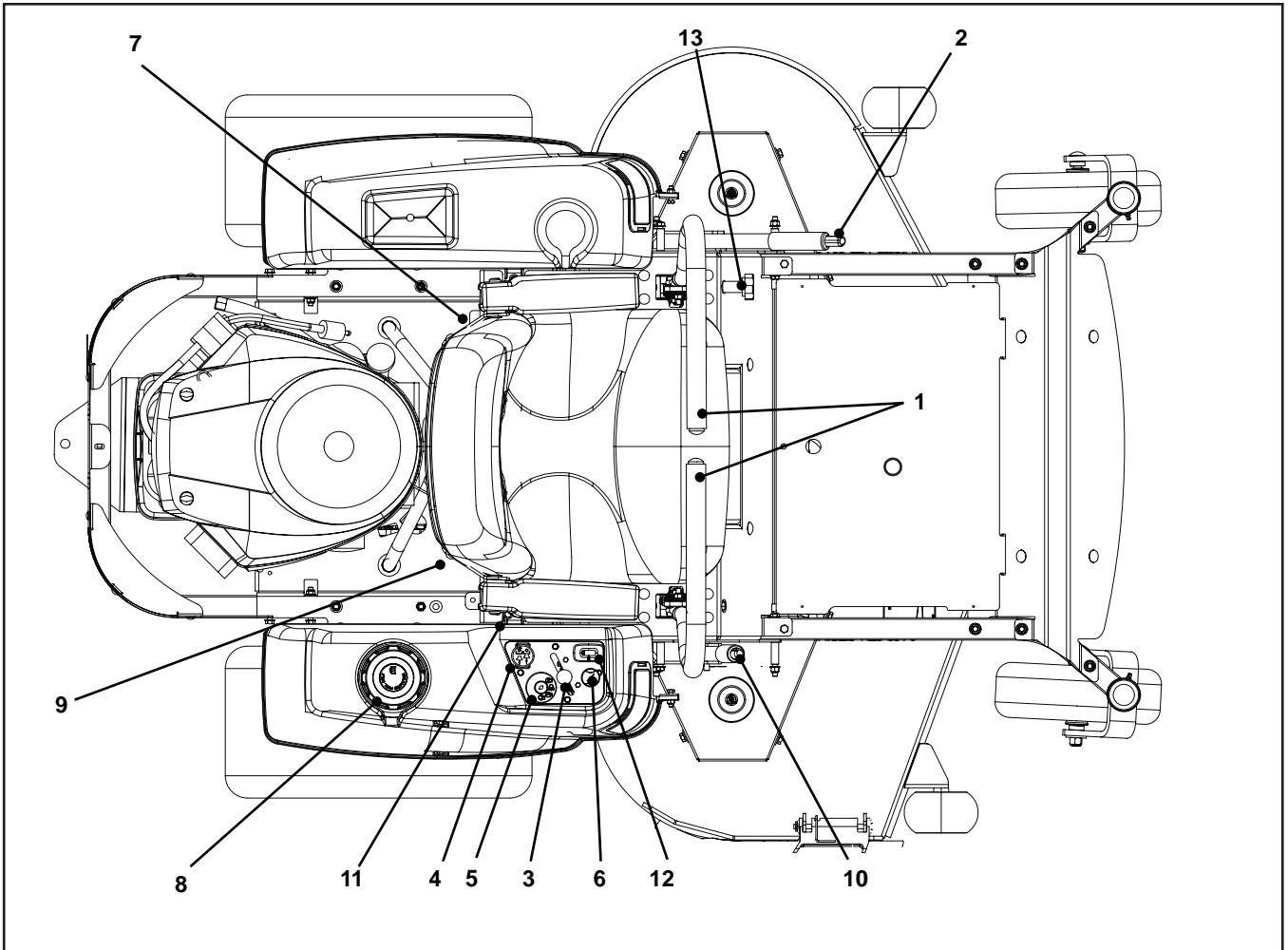

- |                          |                           |
|--------------------------|---------------------------|
| 1. Motion control levers | 8. Fuel tank cap          |
| 2. Parking brake         | 9. Fuel shut off valve    |
| 3. Throttle control      | 10. Deck lift             |
| 4. Blade switch          | 11. Seat adjustment lever |
| 5. Ignition switch       | 12. Hour meter            |
| 6. Choke control         | 13. Tracking adjustment   |
| 7. Fuses                 |                           |

\*As rated by the engine manufacturer.

# CONTROLS

## Steering Control Levers

The machine's speed and direction are continuously variable using the two steering controls. The steering controls can be moved forward or backward about a neutral position. Furthermore, there is a neutral position, which is locked if the steering controls are moved outward.

When both controls are in the neutral position (N), the machine stands still.

By moving both controls an equal amount forward or backward, the machine moves in a straight line forward or backward respectively.

In order, for example, to turn right while moving forward, move the right control towards the neutral position. The rotation of the right wheel is reduced and the machine turns to the right.

Zero turn can be achieved by moving one control backward (behind the neutral position) and carefully moving the other steering control forward from its neutral position. The rotation direction when zero turning is determined by which steering control is moved backward behind the neutral position. If the left steering control is pulled backward, the machine turns to the left. Use extra care when using this maneuver.

If the steering controls are in uneven positions when standing still or do not fit in the slots for moving the controls outward, they can be adjusted.

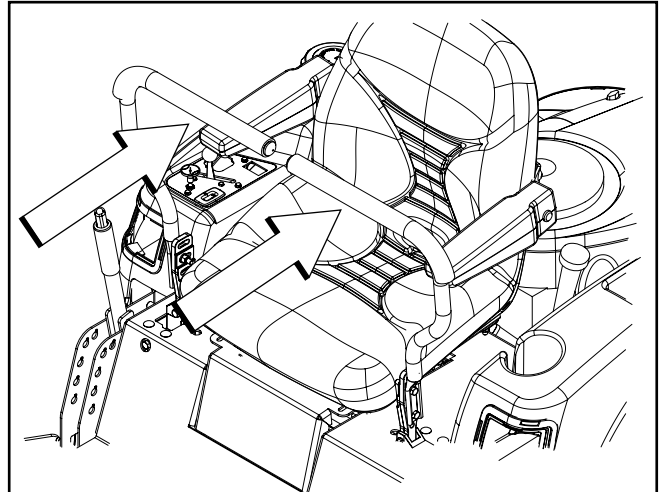

8058-022

Steering controls



### WARNING!

The machine can turn very rapidly if one steering control is moved much further forward than the other.

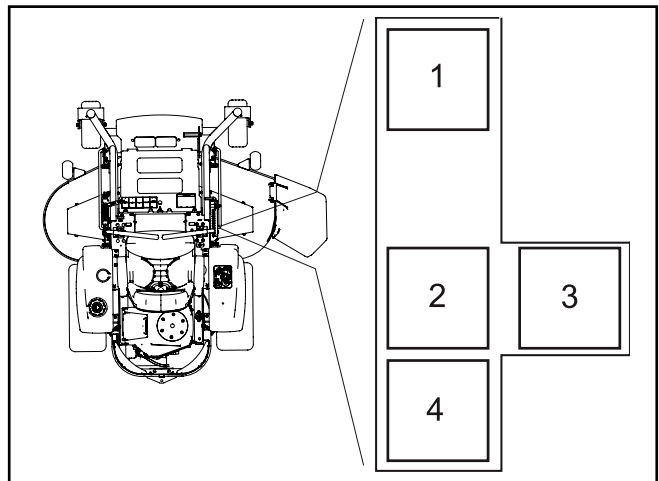

8011-7912a

1. Forward
  2. Neutral
  3. Neutral slot, Neutral lock
  4. Reverse
- Motion control lever, right side*

# CONTROLS

## Parking Brake

### IMPORTANT INFORMATION

The machine must stand absolutely still when applying the parking brake. Always set the parking brake before dismounting. Release the parking brake before moving the mower.

The parking brake is found on the left of the machine. Push the release button and pull the lever backward to activate the brake—push forward to release it.

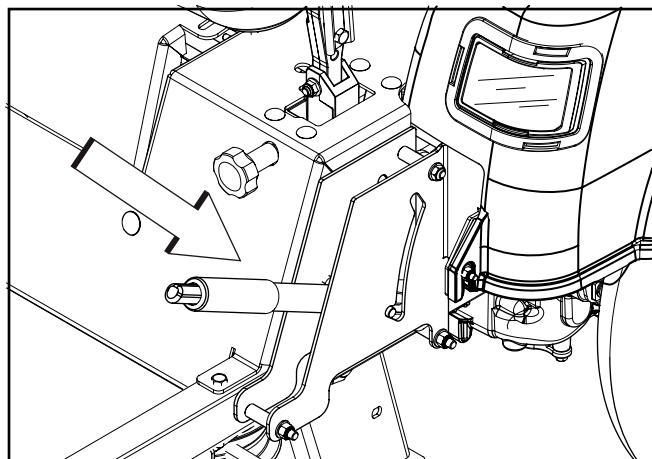

8058-020c

*Parking brake released*

## Throttle Control

The throttle control regulates the engine speed and thereby the rate of rotation of the blades, assuming the blade switch is pulled out, see Engaging the Mower Deck.

In order to increase or decrease the engine speed, the control is moved forward or back respectively.

Avoid idling the engine for long periods, as there is a risk of fouling the spark plugs.

USE FULL THROTTLE WHEN MOWING, for best mower performance and battery charging.

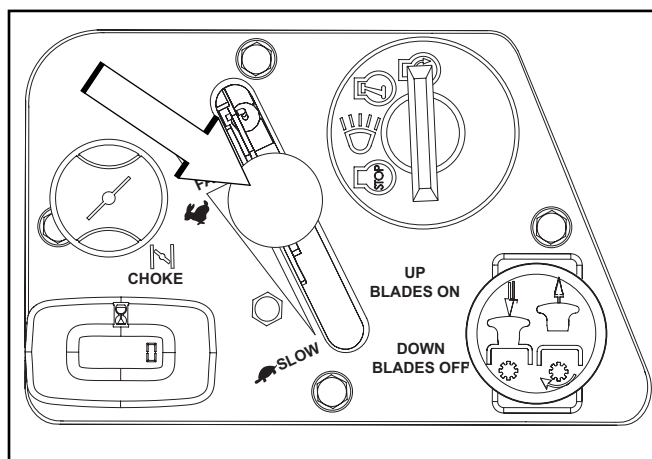

8052-001

*Throttle control*

## Blade Switch

In order to engage the mower deck, pull the knob out; the mower blades are disengaged when the knob is depressed.

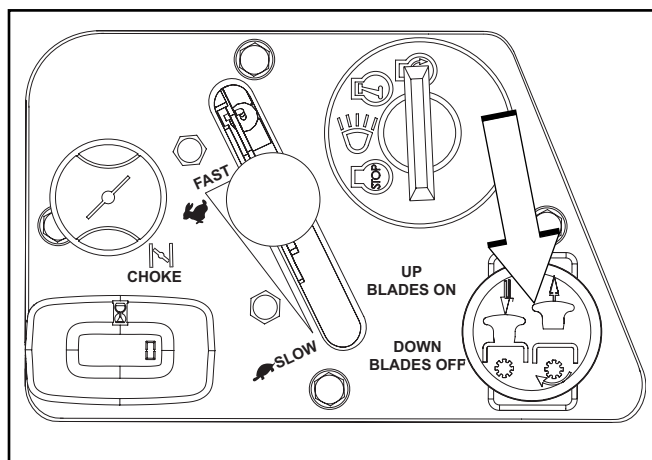

8052-001

*Blade switch*

# CONTROLS

## Ignition Switch

The ignition key is placed on the control panel and is used to start and stop the engine.

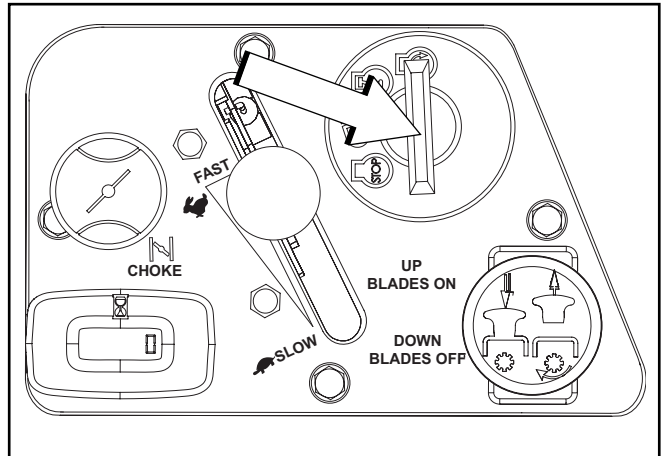

8052-001

Ignition switch

## Choke Control

The choke control is used for cold starts in order to provide the engine with a richer fuel mixture.

For cold starts the control should be pulled out.

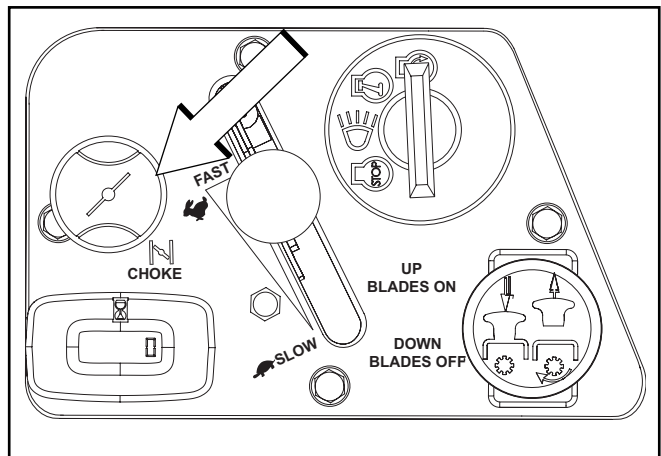

8052-001

Choke control

## Fuses

Fuses are located under the seat of the machine. They are accessed by tilting the seat forward. They are flat pin fuses of the same type used in automobiles.

There are two fuses with ratings and functions:

20 Amp Primary fuse

7.5 Amp Mower deck coupling

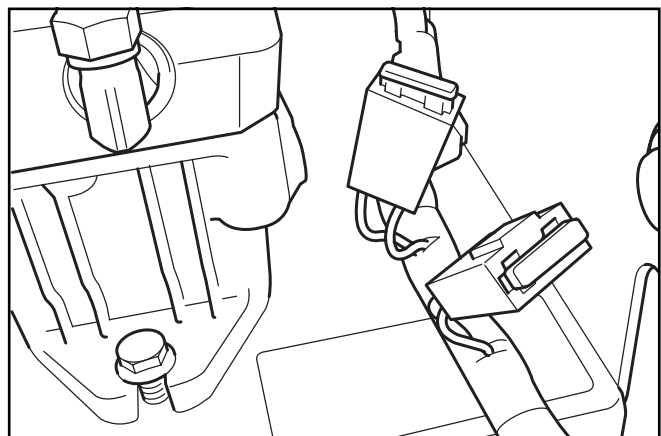

8011-420

Fuses

# CONTROLS

## Fuel Tank

Read the safety instructions before refueling. The machine has one fuel tank, just behind the seat. The tank capacity is 4 gallons (15.1 liters).

Regularly check the gas cap gasket for damage and keep the cap properly tightened.

The engine will run on a minimum of 87-octane unleaded gasoline (no oil mix). Environmentally adapted alkylate gasoline can be used. See also Technical Data concerning ethanol fuel. Methanol fuel is not allowed. Do not use E85 alcohol based fuel. Damage to engine and components may occur.

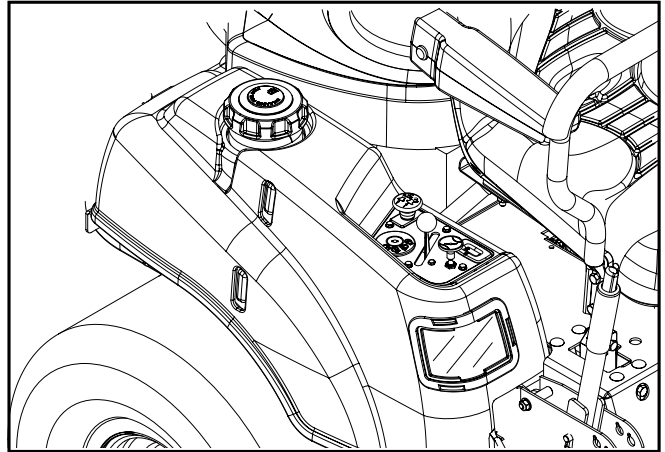

8058-021

Fuel tank



### WARNING!

**Gasoline is highly flammable. Observe caution and fill the tank outdoors (see the safety instruction).**



### WARNING!

**The engine and the exhaust system, become very hot during operation.**

**Risk for burns if touched.**

**Allow engine and exhaust system to cool at least two (2) minutes before refueling.**



### WARNING!

**Fill to bottom of filler neck. Do not overfill. Wipe off any spilled fuel. Do not store, spill or use gasoline near an open flame.**

### IMPORTANT INFORMATION

**Experience indicates that alcohol blended fuels (called gasohol, ethanol or methanol) can attract moisture which leads to separation and formation of acids during storage. Acidic gas can damage the fuel system of an engine while in storage. To avoid engine problems, the fuel system should be emptied before storage of 30 days or longer. Drain the gas tank, start the engine and let it run until the fuel lines and carburetor are empty. Use fresh fuel the next season. See Storage Instructions for additional information. Never use engine or carburetor cleaners in the fuel tank or permanent damage may occur.**

When operating in temperatures below 32° F. (0° C.), use fresh, clean winter grade gasoline to insure good cold weather starting.

# CONTROLS

## Fuel Shut Off Valve

The fuel shut off valve is located at the left rear of the seat. The valve is off when the handle tab is turned perpendicular to the fuel line.

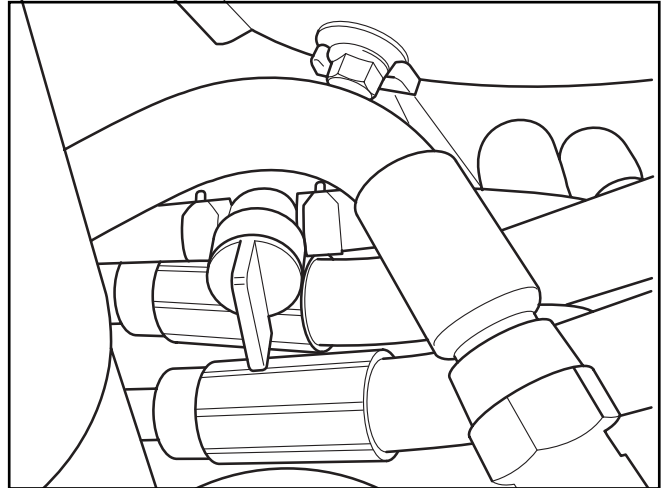

8011-419

*Fuel shut off valve in the CLOSED position*

### IMPORTANT INFORMATION

**Always raise the deck to the highest position for transport.**

## Cutting Height Adjuster

To set the desired deck cutting height, press the release button and move the lever forward to the correct cutting height on the cutting plate. The cutting height range is from 1½" (38mm) to 4" (102mm) in ½" (13mm) increments. The heights are measured from the ground up to the blade tip with the engine not running.

### IMPORTANT INFORMATION

**In order to obtain an even cutting height, it is important that the air pressure in all tires is 15 psi / 103 kPa / 1 bar.**

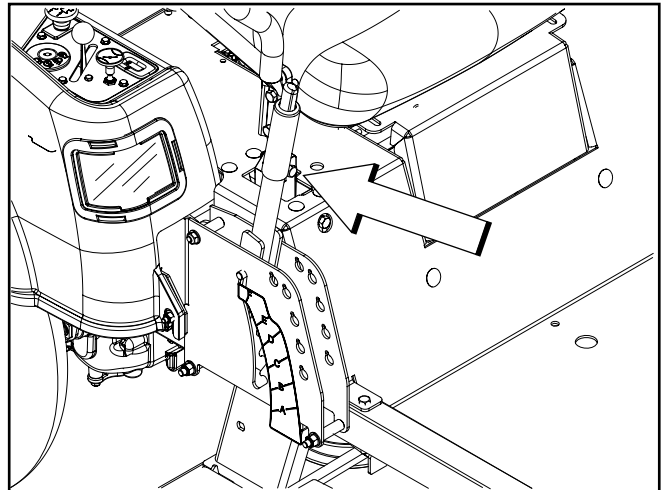

8058-019

*The mower deck's lifting lever*

# CONTROLS

## Seat Adjustment Lever

The seat can be adjusted lengthways. When making adjustments, the lever under the right front side of the seat is pulled to the side, after which the seat can be moved backward or forward.

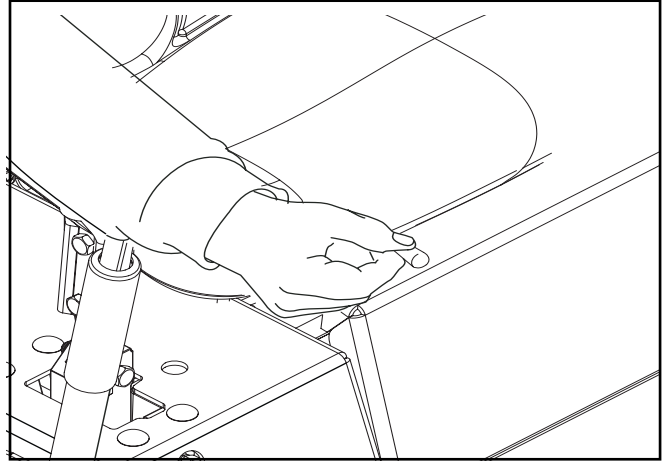

8058-034

*Lengthways adjustment*

## Hour Meter

The hour meter displays the total operating time. It will flash CHG OIL (Change Oil) at 50 hour intervals. The flash duration is one hour before and one hour after the interval. The CHG OIL icon will come on and shut off automatically. The hour meter cannot be manually reset.

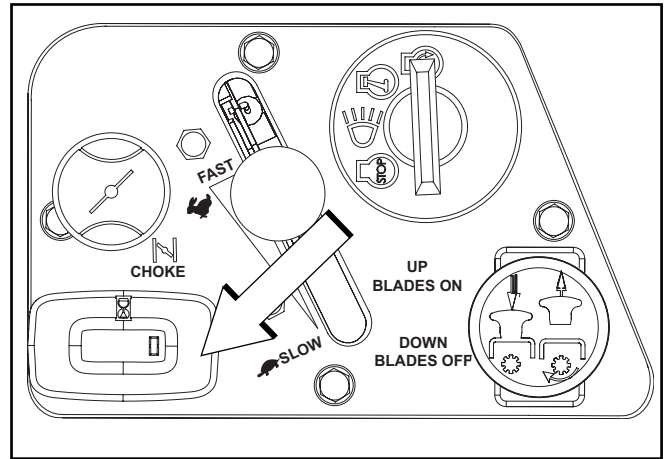

8052-001

*Hour meter*

## Tracking Knob

If the mower is not tracking straight, check the air pressure in both rear tires. Recommended air pressure is 15 psi (103 kPa / 1 bar) for all tires. Tracking must be checked on a flat and level concrete or blacktop surface.

Rotating the tracking knob allows fine tuning adjustments so the machine tracks straight with the steering control levers in the full forward position.

Rotate the knob clockwise (as viewed from the operation position) to increase the speed on the left lever. Rotate counterclockwise to decrease speed.

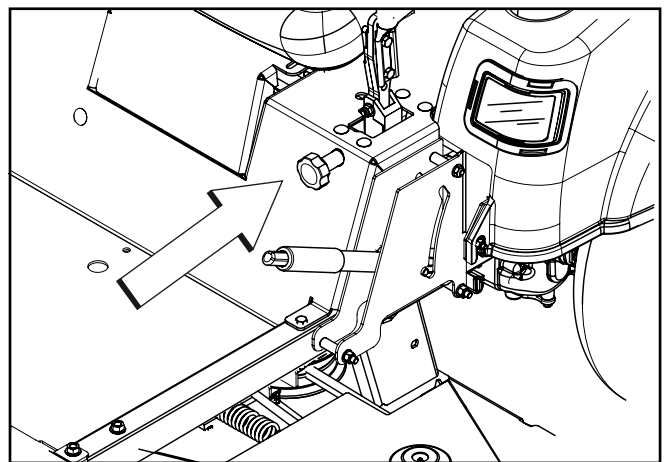

8058-020

*Tracking knob*

---

# OPERATION

---

Read "Safety Instructions" section and following pages, if you are unfamiliar with the machine.

## Training

Zero turn mowers are far more maneuverable than typical riding mowers due to their unique steering capabilities.

We suggest that this section be reviewed in its entirety prior to attempting to move the mower under its own power. Additionally, we suggest when first operating the mower, use a reduced throttle speed and reduced ground speed by NOT moving control levers to the furthest forward or reverse positions during initial operation, or until operator becomes comfortable with controls. We also suggest first time users, or new users to Zero Turn mowers to become familiar with the mower's movement on a hard surface, such as concrete or blacktop PRIOR to attempting to operate on turf. Until operator becomes comfortable with mower controls and zero turning capability, they may damage turf due to overly aggressive maneuvers.

### IMPORTANT INFORMATION

**When control levers are in the reverse position they return to neutral when released. This may cause the mower to suddenly stop.**

## Steering

### To move forward and backward

The direction and speed of the mower's movements is effected by the movement of the control lever(s) on each side of mower. The left control lever controls the left wheel. The right control lever controls the right wheel.

First time users should push mower (see "Moving by Hand" in the *Operation* section) to an open, flat area, without other people or vehicles/obstacles nearby. In order to move unit under its own power, the operator must be in the seat, start engine (see "Before Starting" in *Operation* section), adjust engine speed to idle, disengage parking brake, do not engage blades at this time, rotate control levers inward. As long as the control levers have not been moved forward or backwards, mower will not move. Slowly move both control levers forward slightly. This will allow mower to start moving forward in a straight line. Pull back on control levers to the neutral position and mower should stop moving. Pull back slightly on control levers, this will allow mower to start moving backwards. Push forward on control levers to the neutral position and mower should stop moving.

### To turn to the right

While moving in a forward direction, pull the right lever back towards the neutral position while maintaining the position of the left lever, this will slow the rotation of the right wheel and cause the machine to turn in that direction.

### To turn to the left

While moving in a forward direction pull the left lever back towards the neutral position while maintaining the position of the right lever, this will slow the rotation of the left wheel and cause the machine to turn in that direction.

### To zero turn

While moving in a forward direction, first pull both control levers back until the mower stops or slows dramatically.

Then by alternating one lever slightly to the forward position and the other in the reverse position.



# OPERATION

## Before Starting

- Read the sections Safety Instructions and Controls before starting the machine.
- Perform the daily maintenance before starting (see Maintenance Schedule in the Maintenance section).
- Check that there is sufficient fuel in the fuel tank.
- Adjust the seat to the desired position.

The following conditions must be fulfilled before the engine can be started:

- The blade switch for engaging the mower blades must be depressed.
- The parking brake must be on.
- Both steering controls must be in the locked (outer) neutral position.

## Starting the Engine

- Sit on the seat.
- Raise the mower deck by pushing the release button on the top of the lifting lever. Pull the lifting lever backward to the locked position (transport) position.
- Activate the parking brake by pushing the release button in and pulling the lever fully upwards.

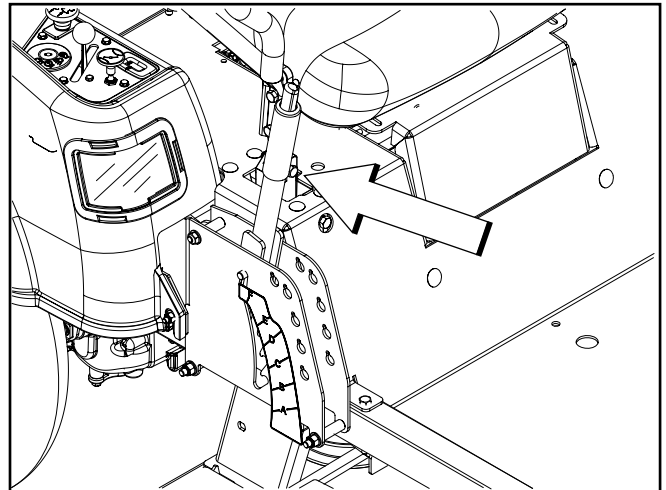

8058-019

Mower deck lifting lever

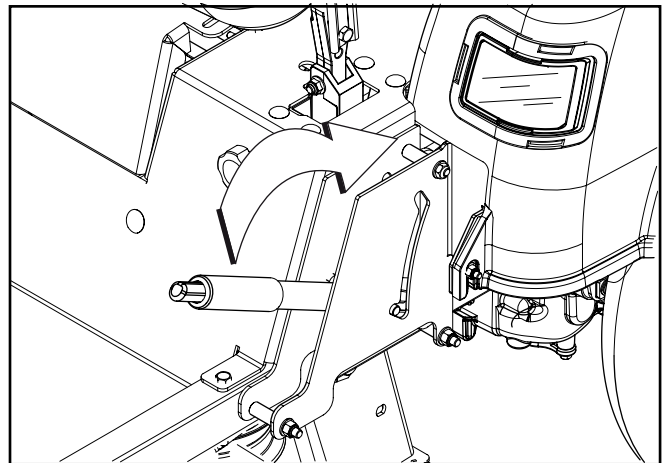

8058-020

Pull parking brake upwards to activate.

Disengage the mower blades by pressing the blade switch downwards.

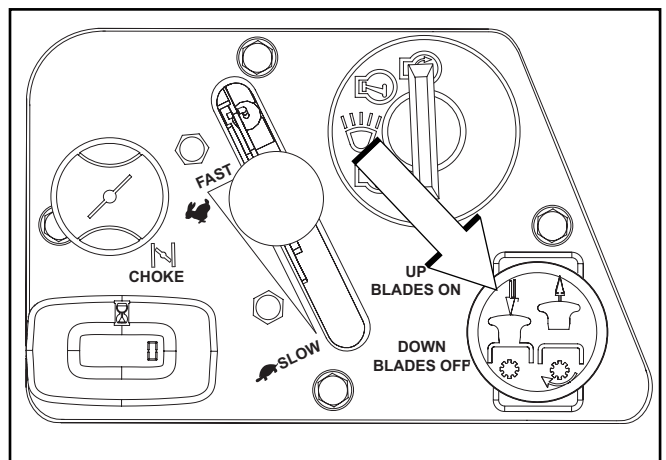

8052-001

Blade switch

# OPERATION

Move the steering controls outward to the locked (outer) neutral position.

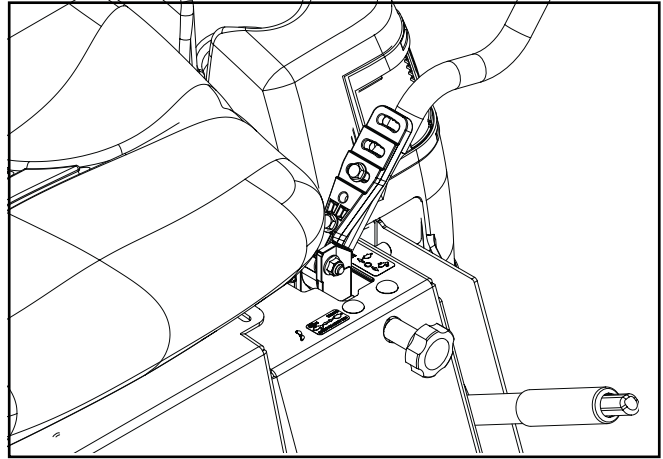

8061-026

*Place controls in neutral position*

Move the throttle to the middle position.

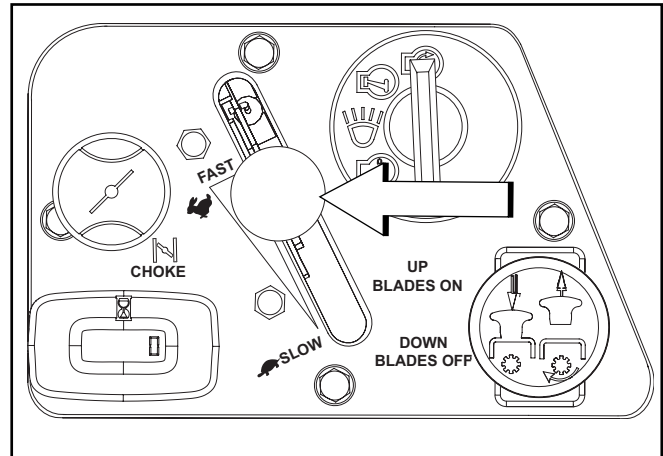

8052-001

*Set the throttle*

If the engine is cold, the choke control should be pulled up.

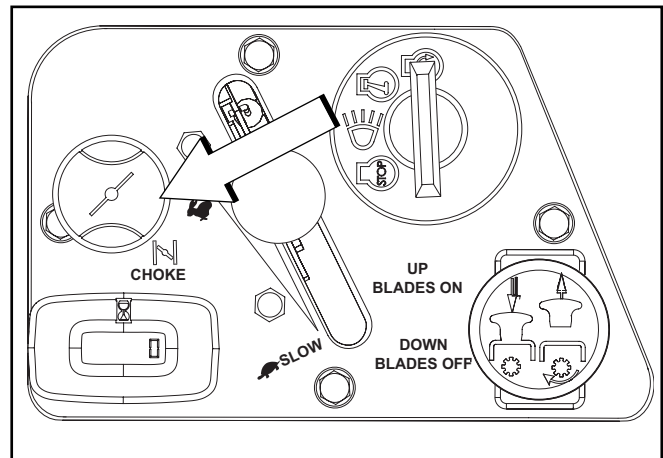

8052-001

*Set the choke control*

# OPERATION

Press in and turn the ignition key to the start position.



## WARNING!

Engine exhaust and certain vehicle components contain or emit chemicals considered to cause cancer, birth defects or other reproductive system damage. The engine exhaust contains carbon monoxide, which is an odorless, colorless, poisonous gas. Do not use the machine in enclosed spaces.

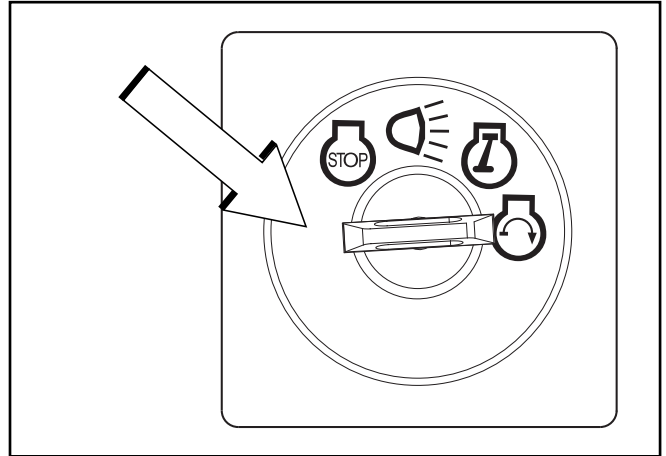

8050-780

*Turn to the start position*

When the engine starts, immediately release the ignition key back to the run position.

## IMPORTANT INFORMATION

Do not run the starter for more than 5 seconds each time. If the engine does not start, wait approximately 10 seconds before retrying.

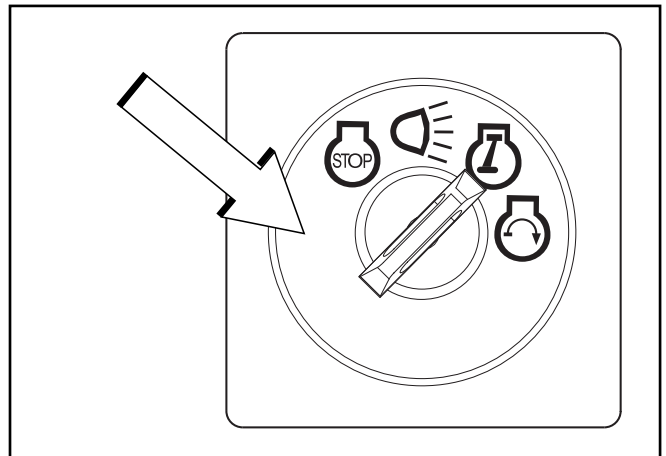

8050-781

*Return to run position*

Set the desired engine speed with the throttle. Allow the engine to run at a moderate speed, "half throttle" for 3-5 minutes before loading it too heavily. **USE FULL THROTTLE WHEN MOWING** (no choke).

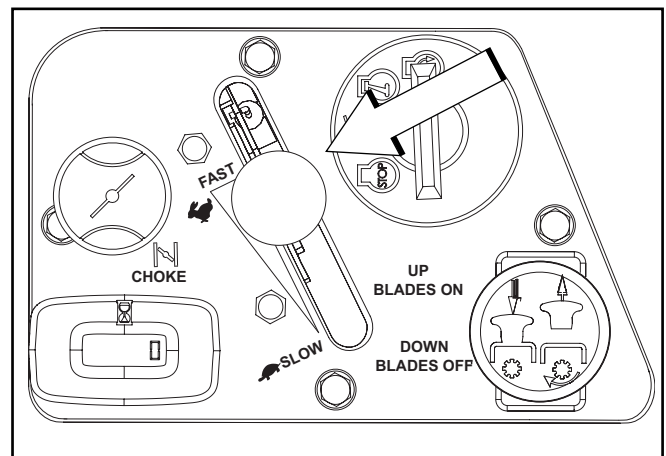

8056-001

*Set the engine speed*

# OPERATION

## Weak Battery



### WARNING!

Lead-acid batteries generate explosive gases. Keep sparks, flame and smoking materials away from batteries. Always wear eye protection when around batteries.



### IMPORTANT INFORMATION

Your mower is equipped with a 12-volt negative grounded system. The other vehicle must also be a 12-volt negative grounded system. Do not use your mower to start other vehicles.

If your battery is too weak to start the engine, it should be recharged. (See "Battery" in the Maintenance Section.)

If "jumper cables" are used for emergency starting, follow this procedure:

### Jumper Cables

- Connect each end of the RED cable to the POSITIVE (+) terminal on each battery, taking care not to short against chassis.
- Connect one end of the BLACK cable to the NEGATIVE (-) terminal of the fully charged battery.
- Connect the other end of the BLACK cable to a good CHASSIS GROUND on the mower with the discharged battery, away from the fuel tank and battery.

### To remove cables, reverse order

- Remove BLACK cable first from chassis and then from the fully charged battery.
- Remove RED cable last from both batteries.

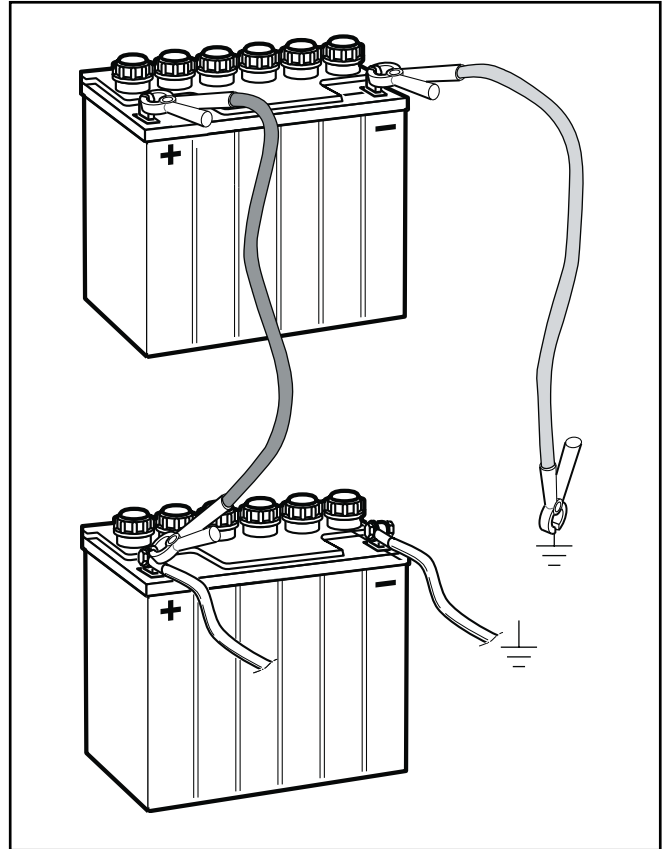

*Jumper cable connection*

8011-642

# OPERATION

## Running

1. Release the parking brake by pushing the button and moving the lever downward.  
NOTE: The mower is equipped with an operator presence system. When the engine is running, any attempt by the operator to leave the seat without first setting the parking brake will shut off the engine.
2. Move the steering controls to the neutral position (N).

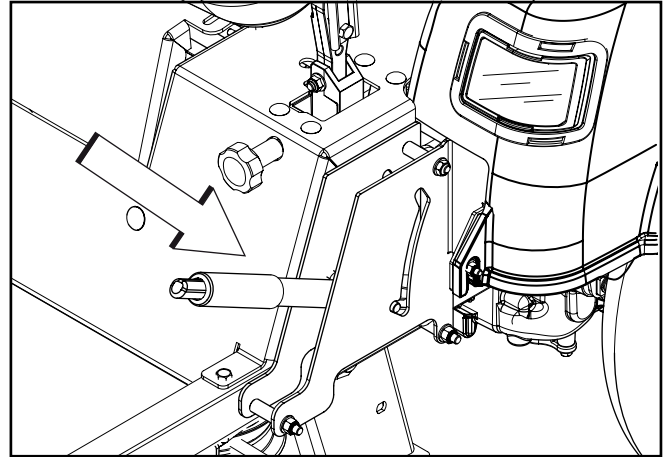

*Parking brake released*

8058-02s0

3. Set retaining pin into selected cutting height and secure the opposite side with a cotter hairpin.



### **WARNING!**

**Ensure that no one is near mower when engaging blade switch.**

**Make sure the work area is free from objects that could be thrown by the rotating blades.**

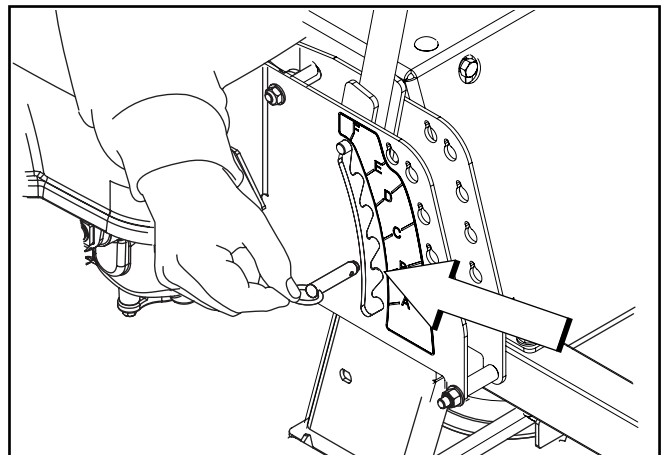

*Secure selected cutting height*

8058-024

4. Push the release button on the cutting height lever and move lever to the pin, release the button.
5. Set the cutting height with the cutting height adjustment lever.

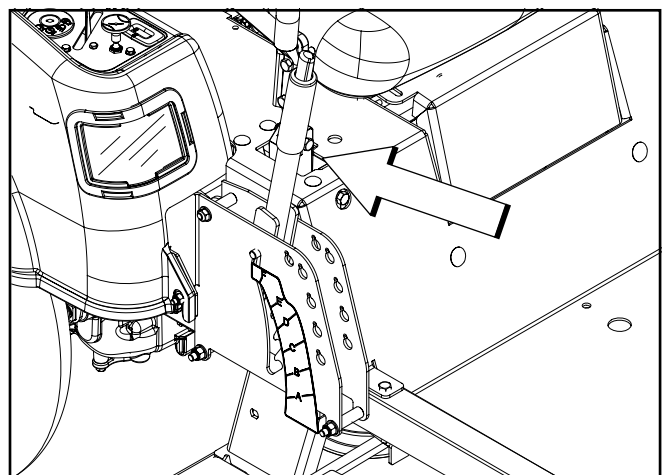

*Mower deck lifting lever*

8058-019

# OPERATION

6. Engage the mower deck by pulling out the blade switch.

7. Move throttle control to full throttle.

The machine's speed and direction are continuously variable using the two steering controls. When both controls are in the neutral position, the machine stands still.

By moving both controls an equal amount forward or backward, the machine moves in a straight line forward or backward respectively.

In order, for example, to turn right while moving forward, move the right control towards the neutral position. The rotation of the right wheel is reduced and the machine turns to the right.

Turning on the spot (zero turn) can be achieved by moving one control backward (behind the neutral position) and carefully moving the other steering control forward from its neutral position.

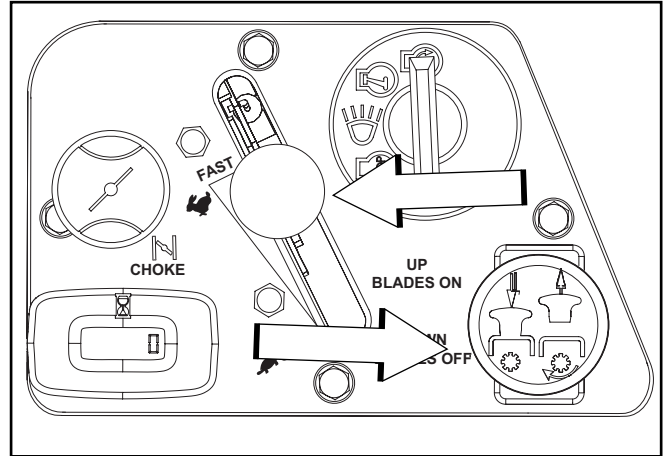

8052-001

Set blade engagement and throttle control

## Operating On Hills

Read the Safety Instructions "Driving on Slopes" in the "Safety Instructions".



### WARNING!

**Do not drive up or down hills with slopes greater than 10 degrees. Do not drive across slopes.**

- The slowest speed possible should be used before starting up or down hills.
- Avoid stopping or changing speed on hills.
- If stopping is absolutely necessary, pull drive levers into the neutral position and push to the outside of the unit and engage the parking brake.

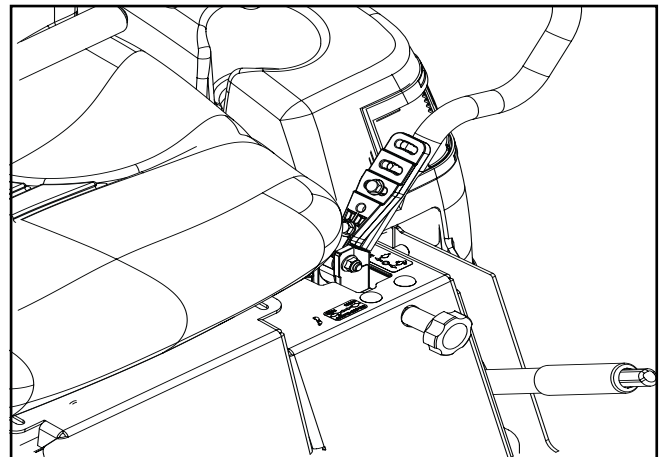

8061-026

Place controls in neutral position

### IMPORTANT INFORMATION

**Control levers return to neutral when released. This may cause the mower to suddenly stop.**

- To restart movement, release the parking brake.
- Pull the control levers back to the center of the mower and press forward to regain forward motion.
- Make all turns slowly.

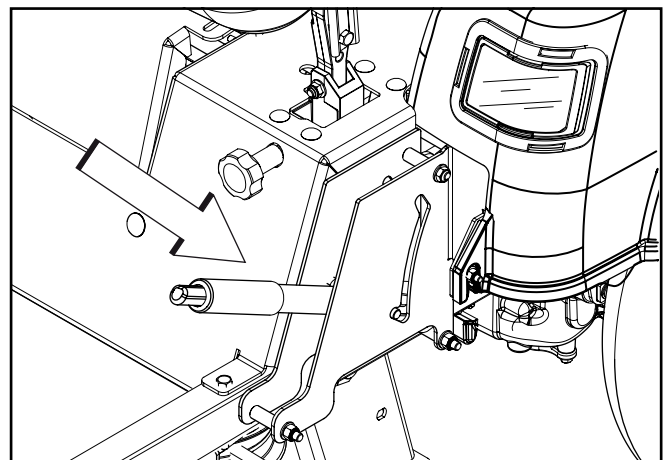

8058-020c

Parking brake released

# OPERATION

## Mowing Tips

- Observe and flag rocks and other fixed objects to avoid collisions.
- Begin with a high cutting height and reduce it until the desired mowing result is attained. The average lawn should be cut to 2½" (64 mm) during the cool season and over 3" (76 mm) during the hot months. For healthier and better looking lawns, mow often after moderate growth. For best cutting performance, grass over 6" (15 cm) in height should be mowed twice. Make the first cut relatively high, the second to the desired height.
- The mowing result will be best with a high engine speed (the blades rotate rapidly) and low speed (the rider moves slowly). If the grass is not too long and dense, the driving speed can be increased without negatively affecting the mowing result.
- The finest lawns are obtained by mowing often. The lawn becomes more even and the grass clippings more evenly distributed over the mown area. The total time taken is not increased as a higher operating speed can be used without poor mowing results.
- Avoid mowing wet lawns. The mowing result is poorer because the wheels sink into the soft lawn, clumps build, and the grass clippings fasten under the cowling.
- Hose the mower deck underside with water after each use. When cleaning, the mower deck shall be raised into the transport position. Make sure the mower is cooled and the engine is off.
- Use compressed air to clean top surface of the deck. Avoid flooding water on top surface, engine and electrical components.
- When the mulching kit is used, it is important that the mowing interval is frequent.



### WARNING!

Clear the lawn of stones and other objects that can be thrown out by the blades.

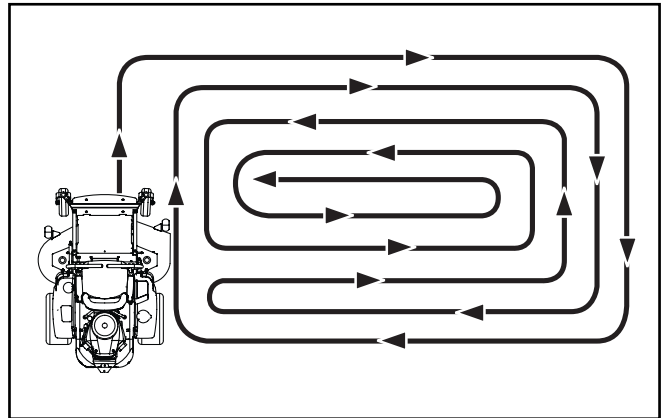

*Mowing pattern*

8011-603



### WARNING!

Never drive the rider on terrain that slopes more than 10 degrees. Mow slopes up and down, never side to side. Avoid sudden directional changes.

# OPERATION

## Stopping the Engine

Allow the engine to idle a minute in order to attain normal operating temperature before stopping it, if it has been worked hard. Avoid idling the engine for longer periods, as there is a risk of the spark plugs fouling.

- Disengage the mower deck by depressing the blade switch.

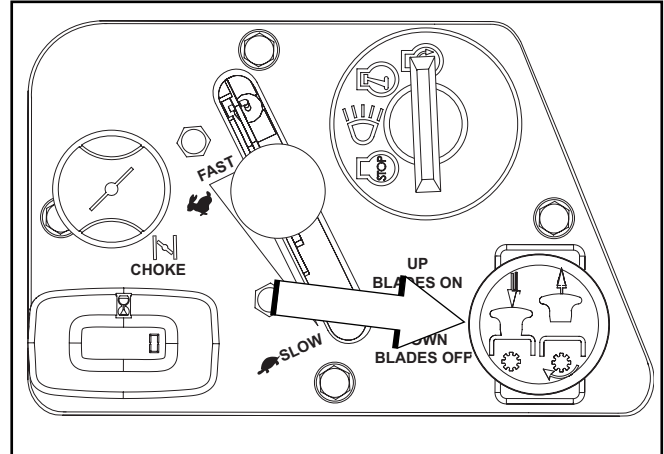

8052-001

*Disengage the mower deck and move throttle to minimum*

- Raise the mower deck by pressing the button on the lever and pulling backward to the transport position.
- When the machine is standing still, activate the parking brake by pushing the lever button and pulling the lever upward.
- Move the throttle to the minimum position (tortoise symbol). Turn the ignition key to the stop position.

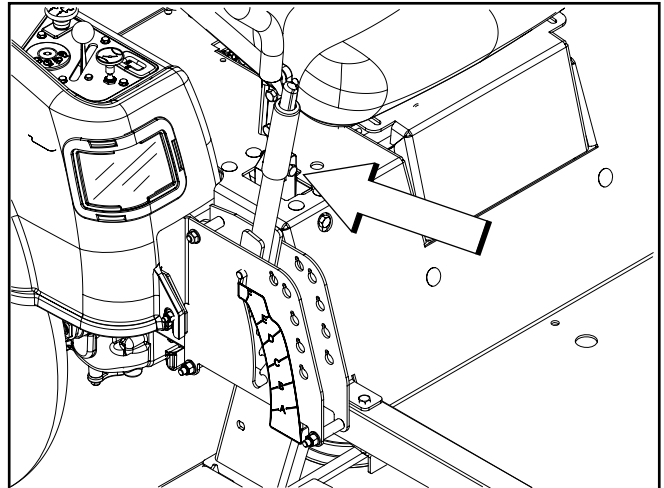

8058-019

*The mower deck's lifting lever*

- Move the steering controls outward.
- Remove key. Always remove key when leaving the mower to prevent unauthorized use.

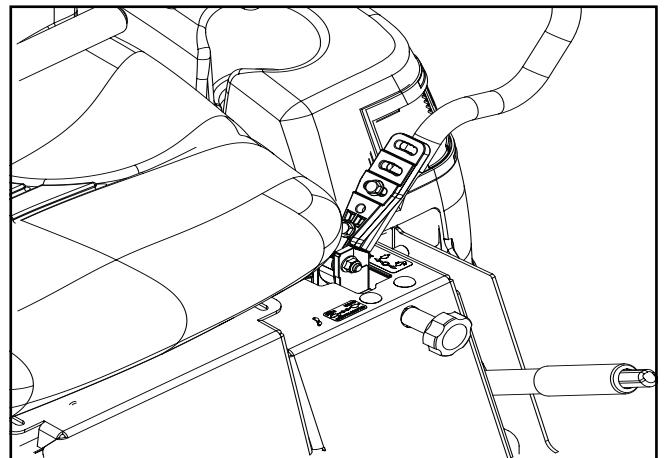

8061-026

*Place controls in neutral position to stop*

### IMPORTANT INFORMATION

**Leaving the ignition switch in any other position than "OFF" will cause the battery to be discharged.**



# OPERATION

## Manual Transport

When pushing or pulling the mower, engage the transmission (Integrated Zereturn Transaxle) bypass linkages. The transmission bypass linkages are located on the rear of the frame, below the rear engine guard.

1. Raise the deck into the highest cutting position.
2. Pull the transmission bypass linkages up and out of the keyhole slots. Release the levers with the head outside the frame and held in the bypass position.
3. To reengage the transmission to drive, reverse the above procedure.

Load the machine into truck or trailer by driving up ramps in low gear. **DO NOT LIFT!** The machine is not intended to be lifted by hand.

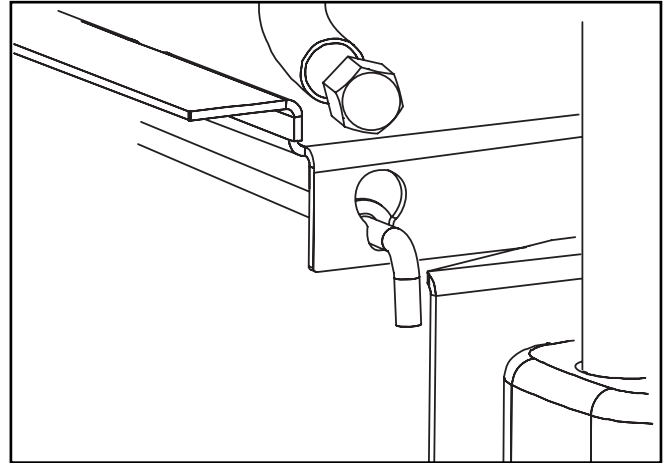

8058-032

*Bypass linkage, transmission engaged*



### **WARNING!**

**Make no adjustments without:**

- the engine stopped,
- the ignition key removed,
- the parking brake activated

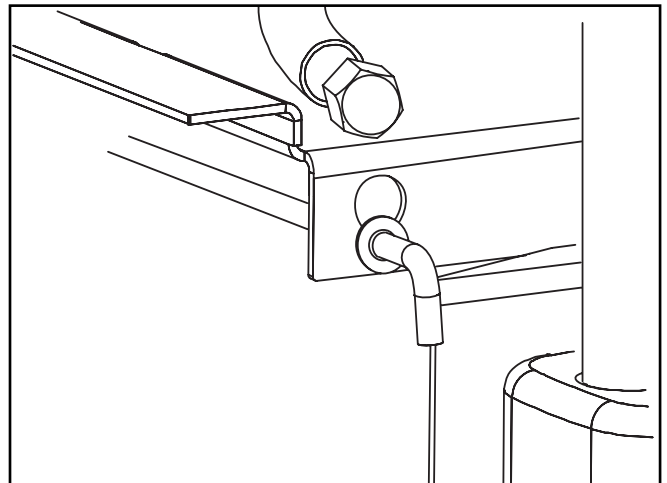

8058-033

*Bypass linkage, transmission locked in the bypass position*

# MAINTENANCE

## Maintenance Schedule

The following is a list of maintenance procedures that must be performed on the machine. For those points not described in this manual, visit an authorized service workshop. An annual service carried out by an authorized service workshop is recommended to maintain your machine in the best possible condition and to ensure safe operation.

Read "Maintenance" in the Safety Instructions section.

<sup>1)</sup> First change after 5-8 hours. When operating with a heavy load or at high ambient temperatures, replace every 50 hours. <sup>2)</sup> In dusty conditions, cleaning and replacement are required more often. <sup>3)</sup> Performed by authorized service workshop.

● = Described in this manual

◆ = Not described in this manual

Maintenance	Daily		Weekly	At least once each year	Maintenance interval in hours			
	Before	After			25	50	100	300
Check the parking brake	●							
Check the engine's oil level (every refueling)	●							
Check the safety system	●							
Check for fuel and oil leakages	◆							
Check/clean the engine's cooling air intake		●						
Check the mower deck		●						
Check for loose hardware (screws, nuts)		●						
Clean under the mower deck		●						
Start the engine and blades, listen for unusual sounds		◆						
Check for damage		◆						
Thoroughly clean around the engine		◆						
Clean around belts, belt pulleys		◆						
Check the tire pressures					●			
Check battery					●			
Sharpen/Replace mower blades					●			
Clean the engine's cooling air intake 2)				●	●			
Clean the air cleaner's pre-filter 2) (foam)				●	●			
Clean the air cleaner's filter cartridge 2) (paper filter)				●		●		
Check/adjust the parking brake				◆		◆		
Inspect muffler/Spark arrester				◆		◆		

# MAINTENANCE

Maintenance	Daily		Weekly	At least once each year	Maintenance interval in hours			
	Before	After			25	50	100	300
Check/adjust throttle cable							●	
Check the condition of belts, belt pulleys				●			●	
Change the engine oil <sup>1)</sup>				●		●		
Replace the engine oil filter				●			●	
Clean/replace the spark plugs				●			●	
Replace the fuel filter				●			●	
Replace the air filter (paper filter) <sup>2)</sup>				●			●	
Check the caster wheels (every 200 hours)							●	
Replace the air cleaner's pre-filter <sup>2)</sup> (foam)				●				
Check/adjust the mower deck				●				●
Check the engine valve clearance <sup>3)</sup>				◆				◆
Perform the 300-hour service <sup>3)</sup>				◆				◆

<sup>1)</sup> First change after 5-8 hours. When operating with a heavy load or at high ambient temperatures, replace every 50 hours. <sup>2)</sup> In dusty conditions, cleaning and replacement are required more often. <sup>3)</sup> Performed by authorized service workshop.

● = Described in this manual

◆ = Not described in this manual



## WARNING!

### Before performing any service or adjustment checklist

- Engage the parking brake.
- Place the Blade-switch in the disengaged position.
- Turn the ignition switch to "OFF" position and remove the key.
- Make sure the blades and all moving parts have completely stopped.
- Disconnect the spark plug wire from all spark plugs and place the wire where it cannot come in contact with the plug.

# MAINTENANCE

## Battery

Your mower is equipped with a maintenance free battery and does not need servicing. However, periodic charging of the battery with an automotive type battery charger will extend its life.

- Keep battery and terminals clean.
- Keep battery bolts tight.
- See chart for charging times

STANDARD BATTERY	STATE OF CHARGE	APPROXIMATE BATTERY CHARGING TIME* TO FULL CHARGE AT 80°F / 27°C			
		Maximum Rate at:			
		50 Amps	30 Amps	20 Amps	10 Amps
12.6V	100%	- FULL CHARGE -			
12.4V	75%	20 min.	35 min.	48 min.	90 min.
12.2V	50%	45 min.	75 min.	95 min.	180 min.
12.0V	25%	65 min.	115 min.	145 min.	280 min.
11.8V	0%	85 min.	150 min.	195 min.	370 min.

\*Charging time depends on battery capacity, condition, age, temperature and efficiency of charger

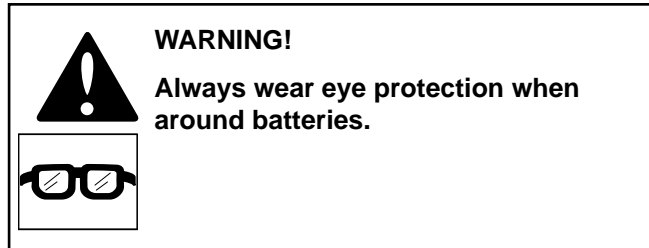

## IMPORTANT INFORMATION

**Do not attempt to open or remove caps or covers. Adding or checking level of electrolyte is not necessary.**

**Always use two wrenches for the terminal screws.**

## Cleaning battery and terminals

Corrosion and dirt on the battery and terminals can cause the battery to “leak” power.

1. Move terminal covers.
2. Disconnect BLACK battery cable first, then the RED battery cable and remove the battery from the machine.
3. Rinse the battery with plain water and dry.
4. Clean terminals and battery cable ends with wire brush until shiny.
5. Coat terminals with grease or petroleum jelly
6. Reinstall battery.

## Replacing battery

1. Lift seat and rotate forward.
2. Using two ½” wrenches disconnect BLACK battery cable then RED battery cable.
3. Position deck to lowest setting.
4. Front underside of frame, remove the nuts that secure the battery hold-down.
5. Carefully remove the battery from the mower.
6. Install new battery with terminals in the same position as the old battery.
7. Reinstall battery hold-down and secure with nuts removed in Step 4.
8. Reconnect RED battery cable to positive (+) battery terminal with hex bolt and hex nut.
9. Connect BLACK grounding cable to negative (-) battery terminal with remaining hex bolt and nut
10. Replace terminal boot cover.
11. Lower seat

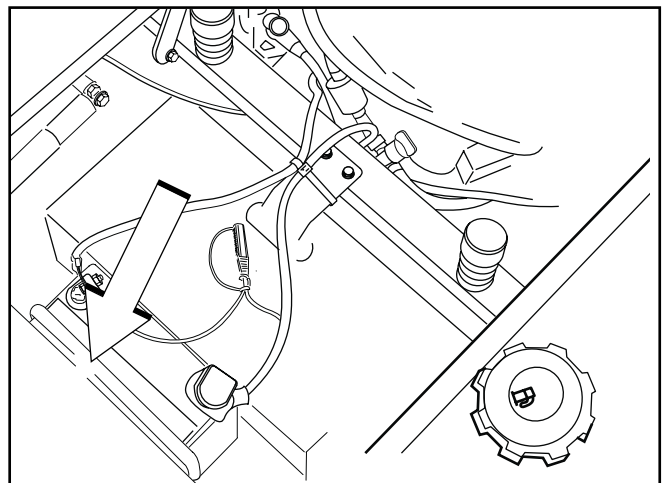
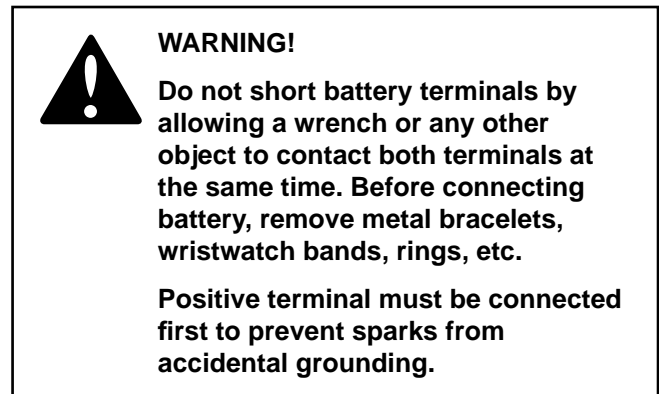

Remove battery hold-down to replace battery

8050-109

# MAINTENANCE

## Ignition System

The engine is equipped with an electronic ignition system. Only the spark plugs require maintenance. For recommended spark plugs, see Technical Data.

1. Remove the ignition cable boot and clean around the spark plug.
2. Remove the spark plug with a spark plug socket wrench.
3. Check the spark plug. Replace the spark plug if fouled, the electrodes are burned and if the insulation is cracked or damaged. Clean the spark plug with a steel brush if it is to be reused.
4. Measure the electrode gap with a gapping tool. The gap should be .030" (0.75 mm). Adjust as necessary by bending the side electrode.
5. Reinsert the spark plug, turning by hand to avoid damaging the threads.
6. After the spark plug is seated, tighten it using a spark plug wrench so that the washer is compressed. A used spark plug should be turned  $\frac{1}{8}$  of a turn from the seated position. A new spark plug should be turned a  $\frac{1}{4}$  turn from the seated position.
7. Replace the ignition cable.

### IMPORTANT INFORMATION

**Fitting the wrong spark plug type can damage the engine.**

**Inadequately tightened spark plugs can cause overheating and damage the engine. Tightening the spark plugs too hard can damage the threads in the cylinder head.**

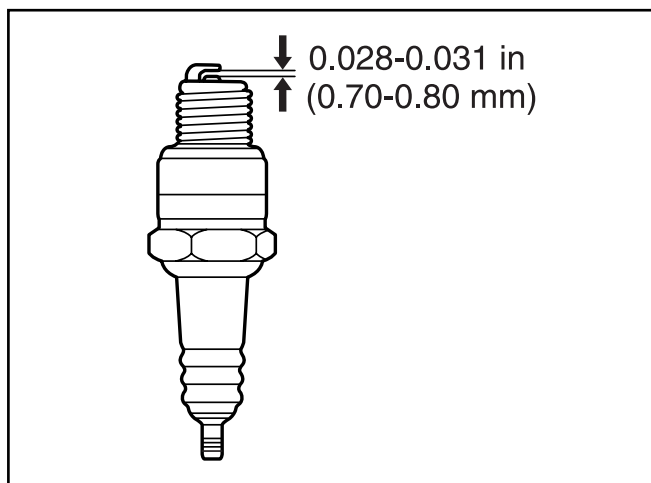

8011-054

*Measure the electrode gap*

## Safety System

The machine is equipped with a safety system that prevents starting or driving under the following conditions.

The engine can only be started when:

1. The mower deck is disengaged.
2. The steering controls are in the outer, locked neutral position.
3. The parking brake is on.

Make daily inspections to ensure that the safety system works by attempting to start the engine when one of the conditions is not met. Change the conditions and try again.

If the machine starts when one of these conditions is not met, turn the machine off and repair the safety system before using the machine again.

Make sure the engine stops when the park brake is not engaged and the operator leaves the seated position.

Check that the engine stops if the mower blades are engaged and the driver temporarily moves off the drivers seat.

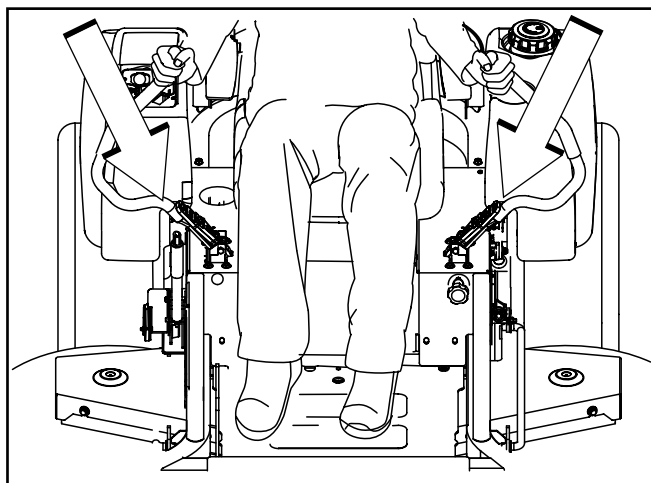

8058-026

*Steering controls locked in neutral*

### IMPORTANT INFORMATION

**In order to be able to drive, the driver must sit in the seat and release the parking brake before the steering controls can be moved into the neutral position, otherwise the engine will stop.**

# MAINTENANCE

## Engine Cooling Air Intake

Check that the engine's cooling air intake is free from leaves, grass, and dirt.

If the cooling air intake is clogged, engine cooling deteriorates, which can lead to engine damage.

The cooling air intakes rotates when the engine is running. Keep fingers away.

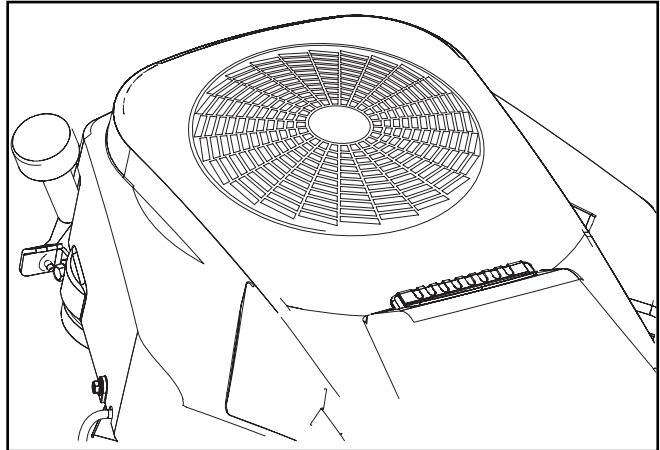

8061-014

*Check and clean the cooling air intake*

## Throttle Cable

Check that the engine responds to throttle increases and that a good engine speed is attained at full throttle.

If doubts arise, contact the service workshop.

If adjustments are necessary, they can be made as follows for the lower cable:

1. Loosen the clamping screw for the cable's outer casing and move the throttle to the full throttle position.
2. Check that the throttle cable is mounted in the correct hole in the lower lever, see illustration.
3. Push the throttle cable's outer casing as far to the right as possible and tighten the clamping screw.

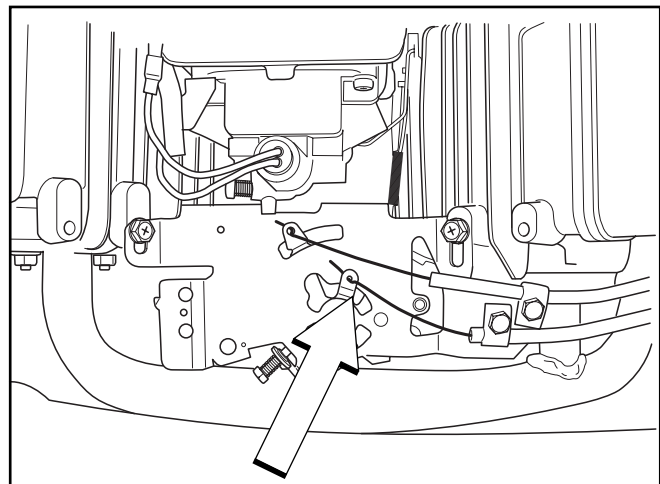

8011-605

*Adjusting the throttle cable*

## Choke Cable

If the engine produces black smoke or is difficult to start, this can be because the choke cable is incorrectly adjusted (upper cable).

If doubts arise, contact the service workshop.

If adjustments are necessary, they can be made as follows:

1. Loosen the clamping screw for the cable's outer casing and push the choke control fully in.
2. Check that the choke cable is mounted in the upper lever, see illustration. Push the choke cable's outer casing as far to the left as possible and tighten the clamping screw.

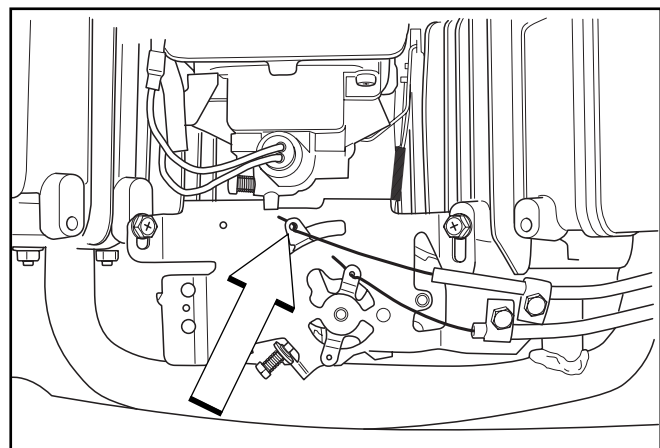

8011-605

*Adjusting the choke cable*

# MAINTENANCE

## Air Filter

If the engine seems weak or runs unevenly, the air filter may be clogged. If running with a dirty air filter, the spark plugs can become fouled.

It is important to replace the air filter regularly (see the heading Maintenance Schedule for the proper service interval).

1. Loosen screws and remove air filter cover.
2. Remove the filter cartridge by pulling upwards along the outside edge.



### WARNING!

The engine and the exhaust system become very hot during operation. Risk for burns if touched.

Allow engine and exhaust system to cool at least two (2) minutes.

### IMPORTANT INFORMATION

Operating the engine with loose or damaged air cleaner components could allow unfiltered air into the engine causing premature wear and failure.

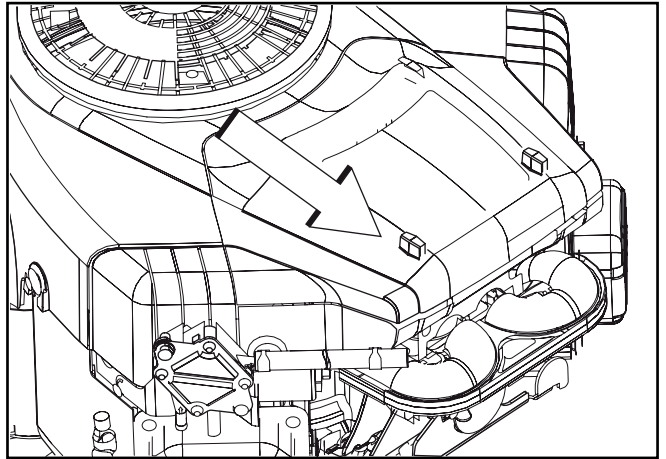

8009-406

Loosen cover screws

3. Remove the foam filter (precleaner). Clean the foam filter with mild detergent and water. Squeeze dry in a clean cloth. Do not oil the foam sleeve.
4. Tap the paper filter against a fixed surface to remove dust. If the paper filter is still dirty, it must be replaced.
5. Wipe clean the inside of air filter housing.
6. Refit the foam filter (pre filter).

### IMPORTANT INFORMATION

Do not use compressed air to clean the air filter.

Do not wash the paper filter.

Do not oil the paper filter.

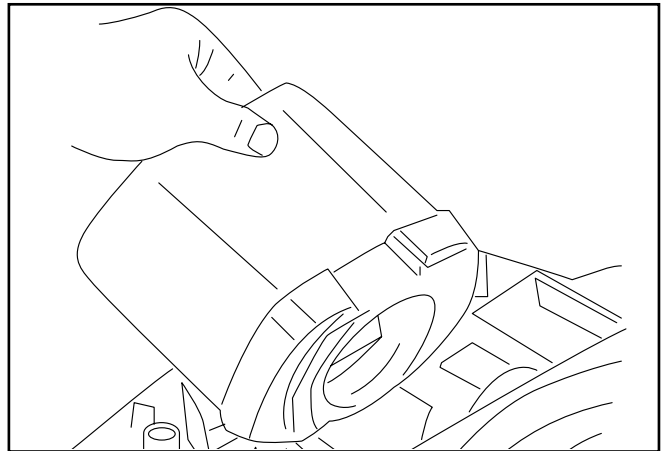

8019-014

Remove filter

# MAINTENANCE

7. Mount the filter in the air filter housing.
8. Replace the cover over the air filter housing and secure with screws.

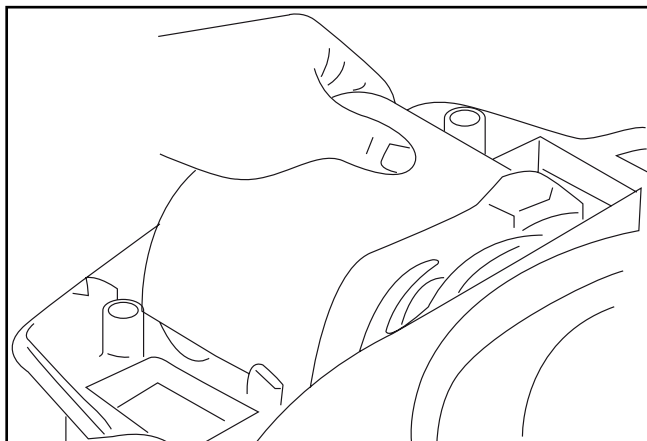

8019-015

*Reinstall filter*

## Fuel Filter

Replace the line-mounted fuel filter every 100 hours (once per season) or more regularly if it is clogged.

1. Replace the filter as follows:
2. Move the hose clamps away from the filter. Use flat-nosed pliers.
3. Pull the filter loose from the hose ends.
4. Push the new filter into the hose ends. Position the filter with the "FLOW" arrow pointing up toward the fuel pump. If necessary, a soap solution can be applied to the filter ends to ease mounting.
5. Move the hose clamps back toward the filter.

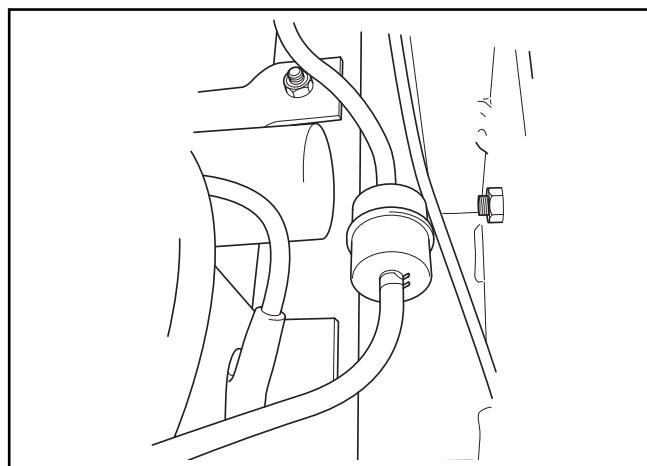

8011-468

*Fuel filter*



# MAINTENANCE

## Tire Pressures

All tires should be at 15 psi / 103 kPa / 1 bar.

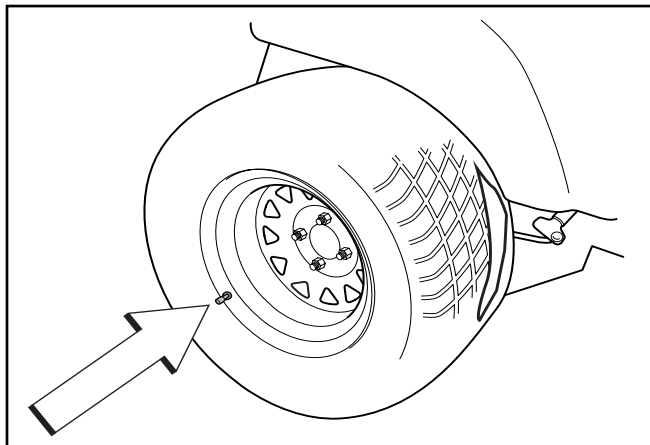

8011-564

Check tire pressures

## Parking Brake

Visually check that no damage is found on the lever, cables, or switch belonging to the parking brake. Perform a standstill test and check that there is sufficient braking action.

To adjust the parking brake, contact the Husqvarna service workshop.

### IMPORTANT INFORMATION

**The machine must be absolutely standing still when applying the parking brake.**

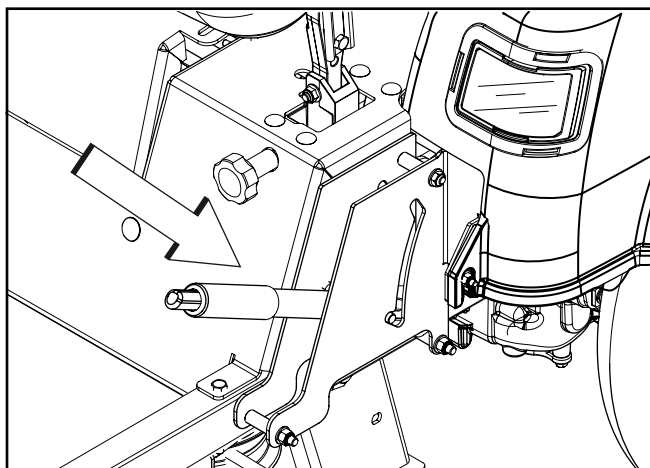

8058-020c

Parking brake



### WARNING!

**Faulty adjustment will result in reduced braking ability and can cause an accident.**

# MAINTENANCE

## V-belts

Check every 100 hours of operation. Check for severe cracking and large nicks.

NOTE: The belt will show some small cracks in normal operation.

The belts are not adjustable. Replace belts if they begin to slip from wear.

## Deck Belt Removal

1. Park on a level surface. Apply parking brake.
2. Lower the deck into the lowest cutting position.
3. Remove bolts from belt shields and remove shields.
4. Remove any dirt or grass that may have accumulated around the cutter housings and entire deck surface.
5. Relieve tension on the belt by moving the idler arm.
6. Carefully slip belt up over the top of the cutter housing pulleys and remove belt. Rolling belt over the pulleys may damage the belt.

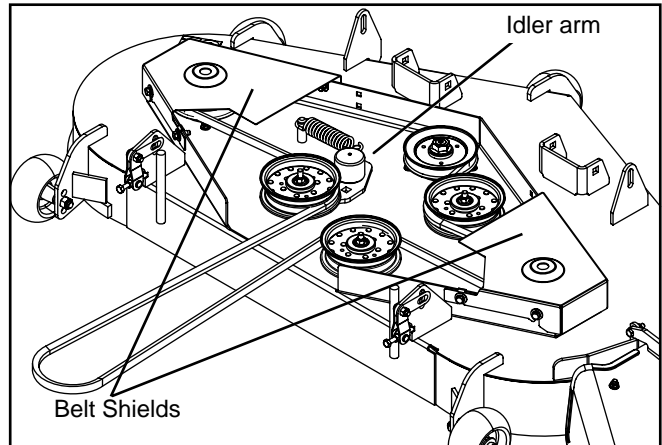

Removing deck belt

## Deck Belt Installation

NOTE: For ease in installing the deck belt, refer to the routing decal on the top of the deck.

1. Wrap the deck belt around the electric clutch pulley that is located on the engine shaft.
2. Route the belt forward and up onto the deck.
3. Place belt around spring loaded idler pulley.
4. Wrap the belt around the stationary idler pulley and around the mandrel housings.
5. Push inward on the idler arm and carefully route belt over stationary idler pulley. Once belt is properly routed, slowly release idler arm to tension belt.
6. Double check belt routing to make sure it matches the routing decal, and the belt does not have any twist. Correct as needed.
7. Replace belt shields on both mandrel housings and secure with fasteners.

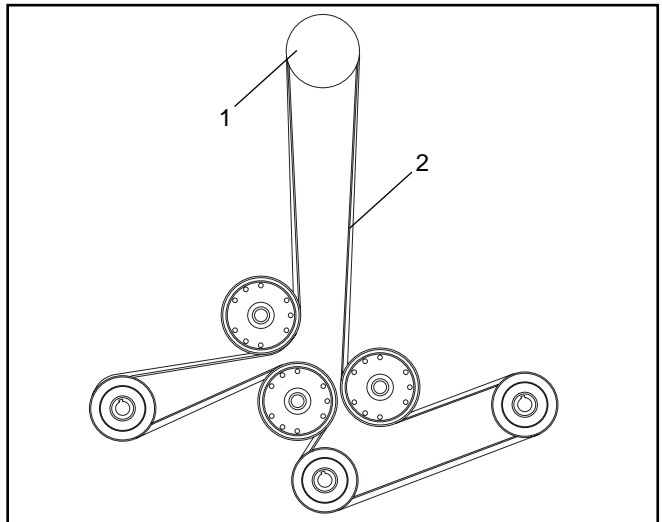

1. Clutch pulley  
2. Deck belt  
Belt routing, deck belt

8011-764

# MAINTENANCE

## Pump Belt

### Replacing pump belt

Park the mower on a level surface. Engage the parking brake.

### Belt removal

1. Remove the deck belt (see Deck Belt Removal in this section of the manual).
2. Create slack in the belt by removing the spring on the pump idler arm.
3. The belt should now be able to be removed from the engine pulley and pump pulleys.

### Belt installation

1. Wrap the belt around the pulley
2. Route the belt around the inside of the idler pulley.
3. Wrap the belt around the engine pulley.
4. Reattach the spring on the pump idler arm.
5. Reinstall the deck belt. (see Deck Belt Installation in this section of the manual).

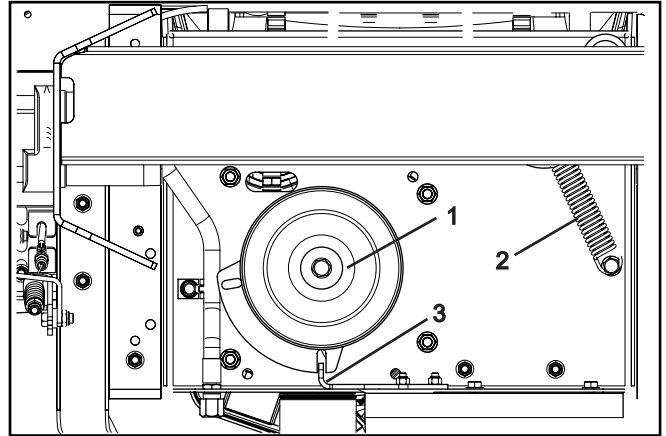

8054-002

1. Electric clutch
  2. Idler spring
  3. Clutch stop
- Pump belt removal*

# MAINTENANCE

## Cutting Blades

In order to attain the best mowing effect, it is important that the blades are well sharpened and not damaged.

Bent or cracked blades or blades with large nicks should be replaced.

### IMPORTANT INFORMATION

**The sharpening of blades should be carried out by an authorized service workshop.**

Damaged blades should be replaced when hitting obstacles that result in a breakdown. Let the service workshop decide whether the blade can be repaired/ground or must be replaced.

Balance the blades after sharpening.

Check the blade mounts.

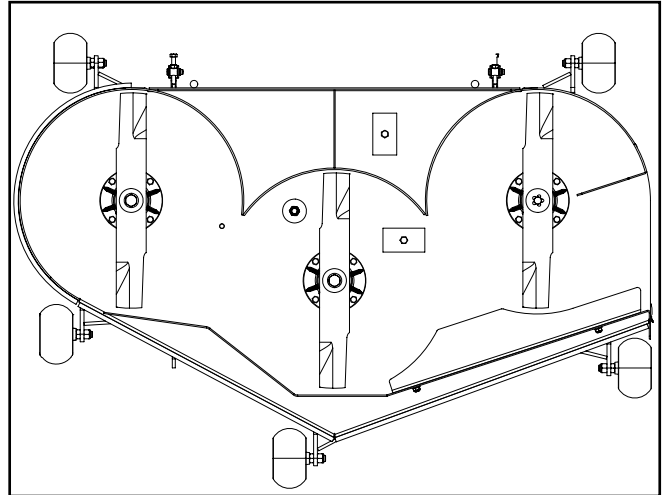

Check the blades

8011-604-1



### WARNING!

**Blades are sharp. Protect your hands with gloves and/or wrap blades with a heavy cloth when handling.**



## Blade replacement

1. Remove blade bolt by turning counterclockwise.
2. Install new or resharpened blade with stamped "GRASS SIDE" facing towards ground/grass (down) or "THIS SIDE UP" facing deck and cutter housing.
3. Install and tighten blade bolt securely.
4. Torque blade bolt to 90 ft/lbs (122 Nm).

### IMPORTANT INFORMATION

**Special blade bolt is heat treated.**

**Replace with an original Husqvarna bolt if required.**

**Do not use lower grade hardware than specified.**

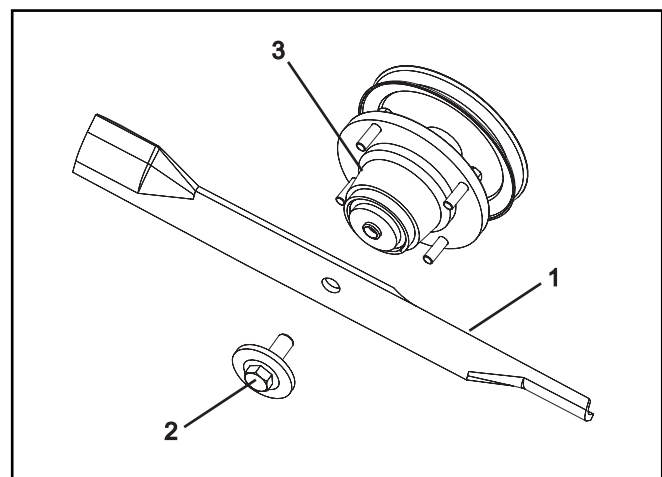

1. Blade
  2. Blade bolt (special)
  3. Cutter housing
- Blade attachment*

# MAINTENANCE

## Adjusting the Mower Deck

### Leveling deck

Adjust the deck while the mower is on a level surface. Make sure the tires are inflated to the correct pressure. See "Technical Data" under Transmission. If tires are under or over inflated, the deck cannot be properly adjusted.

The deck should be adjusted slightly higher in the rear.

NOTE: To insure accuracy of leveling procedure, mower deck drive belt must be installed prior to leveling deck.

1. Wear heavy gloves. Turn each outer blade tip to align with the deck or in a side-to-side manner.
2. Measure from the floor surface up to the bottom of the blade tip on the discharge side of the mower deck. Retain this measurement.
3. Move to the opposite side, check that measurement is the same. If adjustment is required—with a  $\frac{3}{4}$ " or adjustable wrench, turn the lift link adjustment nuts on either side counter clockwise to lower or clockwise to raise. Adjust until both side-to-side measurements are equal.

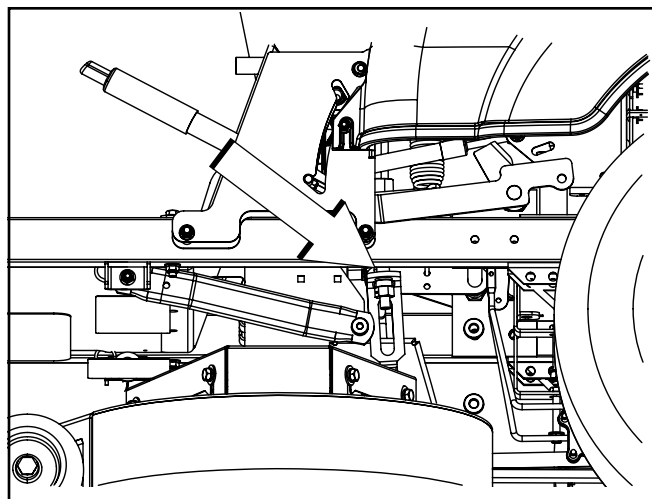

8058-030

Lift link adjustment nut

4. Turn any blade to align with the deck in front-to-rear manner. If the rear blade tip does not measure  $\frac{1}{8}$ " to  $\frac{1}{2}$ " higher, follow the front adjustment instructions that follow.
5. With a  $\frac{5}{8}$ " or adjustable wrench, turn the nuts on the front suspension linkage. Clockwise raises the front of the mower, counter clockwise will lower the front. Adjust nuts until rear of mower deck is positioned level to  $\frac{1}{8}$ " higher in the rear than the side-to-side measurement.

NOTE: This will place the mower deck in a base measurement position. Additional adjustment may be required to achieve desired cut for the type of grass or conditions being mowed.

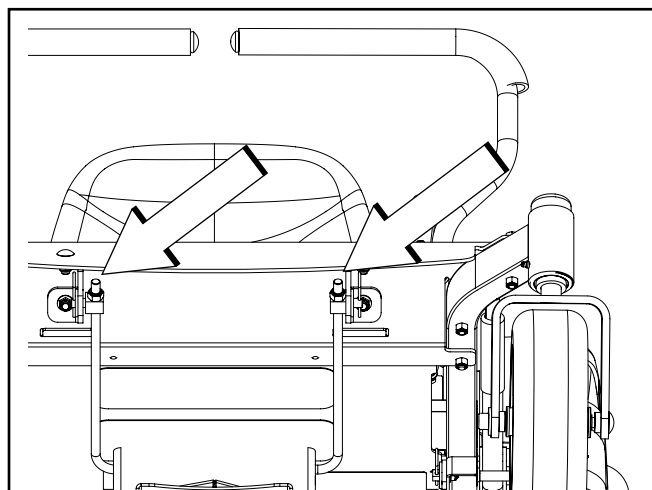

8058-031

Deck front adjustment nuts

# MAINTENANCE

## Anti-scalp rollers

**Anti-scalp rollers** are properly adjusted when they are just slightly off of the ground when the deck is at the desired cutting height in the operating position.

**Anti-scalp rollers** then keep the deck in the proper position to help prevent scalping in most terrain conditions.

### IMPORTANT INFORMATION

**Adjust anti-scalp rollers with the mower on a flat level surface.**

The **anti-scalp rollers** can be set in three positions:

- Upper position 1½ to 2½" (38 to 64 mm) grass
- Middle position 2½" to 4" (64 to 102 mm) grass
- Lower position 4" to 6" (102 to 128 mm) grass.

The rollers should be approximately ¼" (6.5 mm) from ground. Do not adjust the rollers to support the deck.

### IMPORTANT INFORMATION

**The anti-scalp rollers must not be used for gauge wheels or the roller and deck may be damaged.**

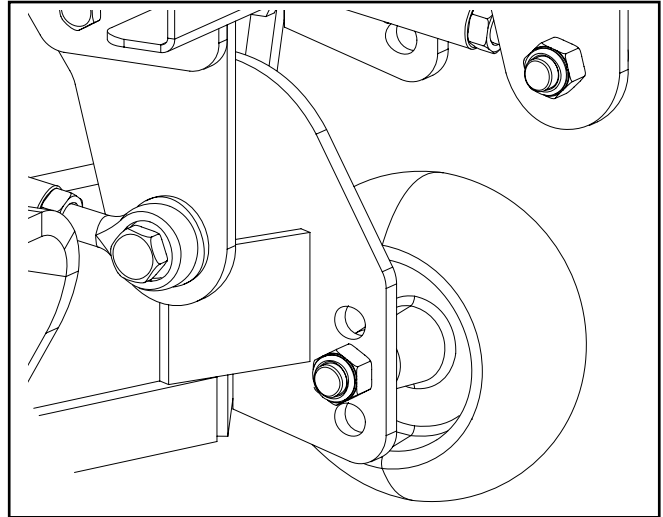

*Anti-scalp rollers*

8050-830

# MAINTENANCE

## Cleaning

Regular cleaning and washing, especially under the mower deck, will increase the machine's life-span. Make it a habit to clean the machine directly after use (after it is cooled), before the dirt sticks.

Do not spray water on the top of the mower deck. Use compressed air to clean the top side of mower deck. Regularly clean deck and underside of the deck with normal water pressure. Do not use a high pressure washer or steam cleaner. Avoid spraying engine and electrical components with water

Do not rinse hot surfaces with cold water. Let unit cool before washing.

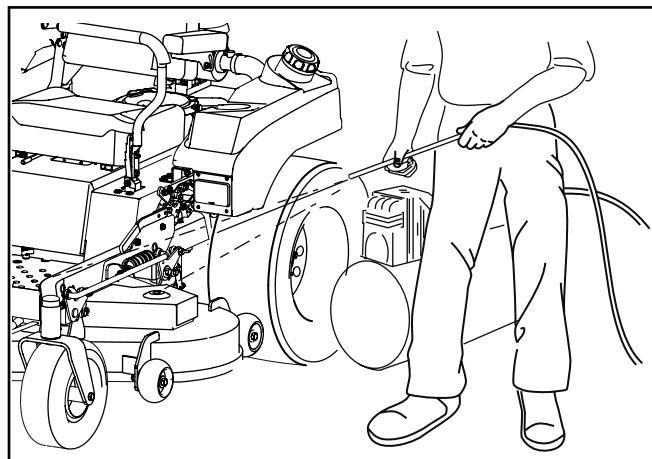

8050-831

*Clean regularly*

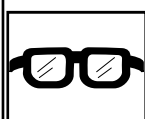

### IMPORTANT INFORMATION

**Use protective glasses when cleaning and washing.**

## Caster Wheels

Check every 200 hours. Check that wheels rotate freely. If wheels do not rotate freely take the unit to your dealer for service.

Foam filled tires or solid tires will void the warranty.

### IMPORTANT INFORMATION

**DO NOT add any type of tire liner or foam fill material to the tires. Excessive loads created by foam filled tires will cause premature failures.**

**Only use O.E.M. specified tires.**

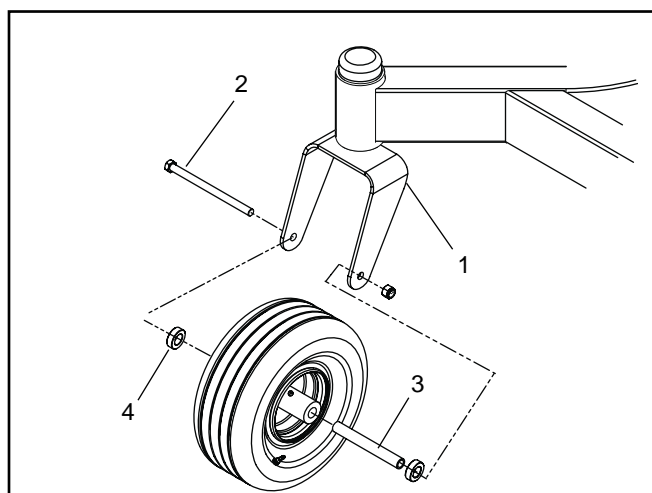

8011-619-4

### Removal and installation of caster wheel

Remove nut and caster bolt.

Pull the wheel out of the yoke and take care of spacers.

Install in reverse order. Tighten caster bolt.

## Hardware

Check daily. Inspect the entire machine for loose or missing hardware.

1. Caster yoke
  2. Caster bolt
  3. Caster long spacer
  4. Caster small spacers (not on all models)
- Caster wheels*

# LUBRICATION

12/12	1/52	1/365		25h	50h	100h	200h	300h
				1 ← (2x)				
				2 ← (2x)				
				3 ←				
				4 ← (2x)				
⚠	👁	5		6				🛢
				*				🛢

8050-832

12/12 Every year	Lubricate with grease gun	←	Lubricate with oil can	🛢
1/52 Every Week	Oil change	⚠	Level check	👁
1/365 Every day	Filter change	🛢		

\* Change transmission filter

## General

Remove the ignition key to prevent unintentional movements during lubrication.

When lubricating with an oil can, it must be filled with engine oil.

When lubricating with grease, unless otherwise stated, use a high grade molybdenum disulphide grease.

For daily use, the machine should be lubricated twice weekly.

Wipe away excess grease after lubrication.

It is important to avoid getting lubricant on the belts or the drive surfaces on the belt pulleys. Should this happen, attempt to clean them with spirits. If the belt continues to slip after cleaning, it must be replaced. Gasoline or other petroleum products must not be used to clean belts.



# LUBRICATION

## Front Wheel Mount

Lubricate with a grease gun, one zerk for each wheel mount, until the grease is forced out.

Use only good quality bearing grease.

Grease from well-known brand names (petrochemical companies) usually maintains a good quality.

## Front Wheel Bearings

Lubricate with a grease gun, one zerk for each set of wheel bearings, until the grease is forced out.

Use only good quality bearing grease.

### IMPORTANT INFORMATION

**Use minimal lubrication and remove excess lubricant so that it does not come into contact with belts or belt pulley drive surfaces.**

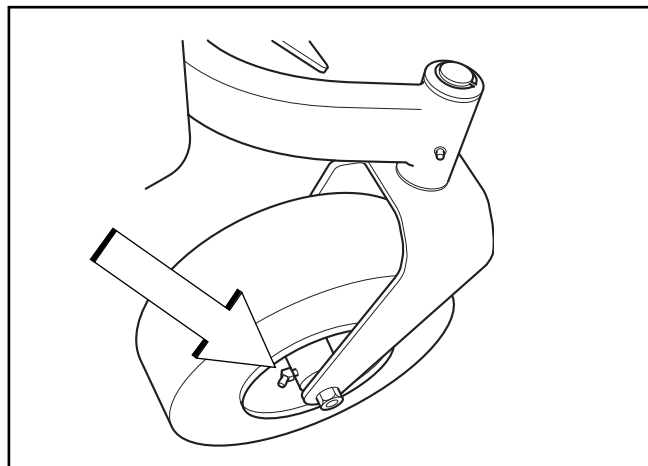

8011-731

*Lubricating the front wheels*

## Deck Spindle

Lower the cutting deck completely.

If a grease gun without a rubber hose is used, the foot plate must be removed.

Lubricate with a grease gun, one zerk, 2-3 strokes.

Use only good quality bearing grease.

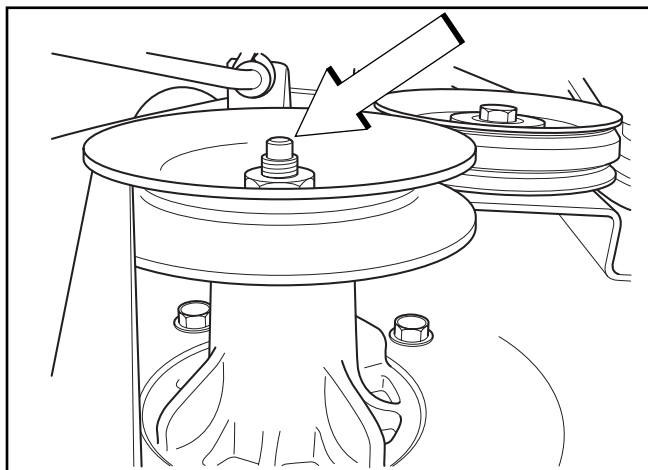

8011-732

*Deck spindle*

## Deck Outer Spindle

Lubricate using a grease gun, one zerk, each side 2-3 strokes. Use only good quality bearing grease.

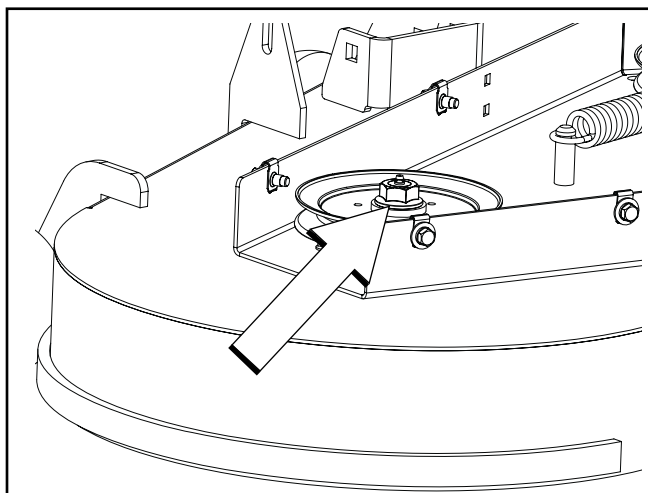

8061-025

*Deck outer spindle (with belt shield removed)*

# LUBRICATION

## Engine Oil



### WARNING!

Engine oil can be very hot if it is drained directly after stopping the engine. Allow the engine to cool to a safe temperature before draining.

### Engine Oil Filter

- Drain the engine oil in accordance with the work description under the heading Engine Oil/Change Engine Oil.
- Remove the oil filter. If necessary, use a filter remover.
- Wipe new, clean engine oil onto the seal for the new filter.
- Mount the filter by hand with  $+\frac{3}{4}$  turn.
- Run the engine warm, then check that there are no leaks around the oil filter seal.
- Check the oil level in the engine, fill if necessary. The oil filter holds 0.1 qt (0.2 liters) of oil.

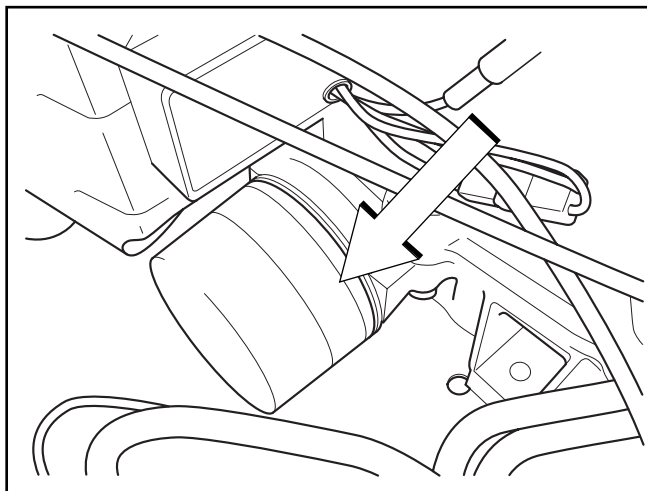

8011-734

*Changing the oil filter*

### IMPORTANT INFORMATION

**Used engine oil is a health hazard and must not be disposed of on the ground or in nature; it should always be disposed of at a workshop or appropriate disposal location.**

**Avoid skin contact; wash with soap and water in case of spills.**

### Engine Oil Levels

Check the oil level in the engine when the machine is standing level and the engine is stopped. Remove the dipstick, wipe it clean, and then replace it. The dipstick should be screwed into place. Take the dipstick out again and read the oil level. The oil level should lie between the markings on the dipstick. If the level is approaching the "ADD" mark, fill the oil to the "FULL" mark on the dipstick. Never fill to above the "FULL" mark. The oil is filled through the hole for the dipstick. API class SF, SG, SH, SJ or higher must be used. Synthetic oil SAE 5W-30 or 10W-30 is recommended at all temperatures. Mineral oil SAE 5W-30, 10W-30 can be used between  $-18\text{ }^{\circ}\text{C}/0\text{ }^{\circ}\text{F}$  and  $+75\text{ }^{\circ}\text{C}/40\text{ }^{\circ}\text{F}$ . At temperature above  $+5\text{ }^{\circ}\text{C}/40\text{ }^{\circ}\text{F}$  single grade SAE 30 must be used. See the Technical Data section for oil amounts.

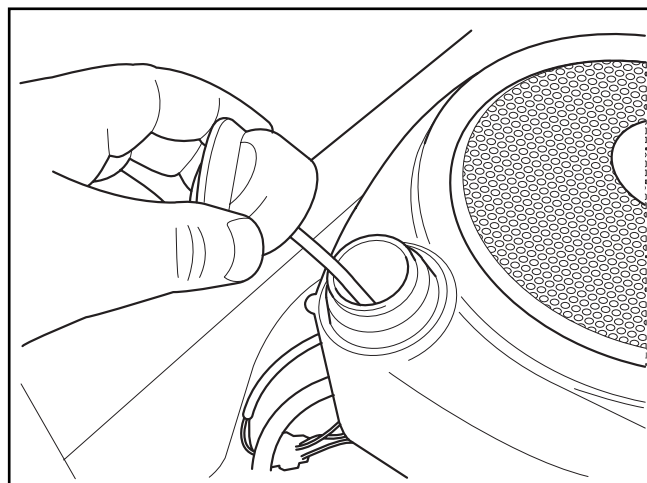

8011-500

*Remove the dipstick*

# LUBRICATION

## Changing the Engine Oil

The engine oil should be changed for the first time after 5-8 hours of operation. Thereafter, it should be changed every 50 hours. The oil drain valve is located on the left side of the unit, below the oil filter.

- Place the machine on a flat surface.
- Place a container under the engine where the oil drain valve exits.
- Remove the valve cap.
- Allow the oil to run out into the container.
- Reinstall the oil drain valve cap.
- Replace the oil filter if necessary.
- Fill with new engine oil in accordance with Checking the Oil Level.
- Start the engine. Run it for 3-5 minutes. Stop and recheck the oil level.

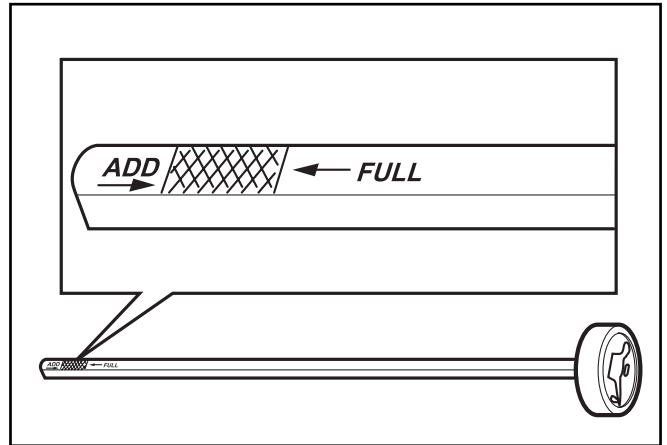

8009-159

*The dipstick markings*

# LUBRICATION

## Transaxle (Transmission) Fluid Change

This transaxle is designed with an external filter for ease of maintenance. To ensure constant fluid quality levels and longer life, an oil filter change interval of every 200 hours is recommended.

The following procedure is performed with the transaxles installed in the mower and the mower on level ground. Apply the pump release valve for each transaxle and set the parking brake.

1. Remove the three ¼" filter guard screws and filter guard. Clean any loose debris from around the perimeter of the filter. See illustration.
2. Place an oil drain pan (12" or more diameter and 8 qt. capacity is optimal) beneath the oil filter. Remove the oil filter from the transaxle.
3. After the oil has drained, wipe the filter base surface and apply a film of new oil to the gasket of the replacement filter.
4. Install the new filter by hand, turning it three-quarters to one full turn after the filter gasket contacts the filter base surface.
5. Reinstall the filter guard. Torque screws to 65 in./lbs. each.
6. Repeat steps on the opposite side.
7. Drain old oil filters of all free flowing oil prior to disposal. Place used oil in appropriate containers and dispose of it in accordance with laws in your area.
8. Remove the top port plug (see illustration) from the left side and right side of the transaxles prior to filling with oil. This will allow the transaxles to vent during oil fill.
9. Remove the cap from the transaxles' expansion tank located on the vehicle frame.
10. Fill with 20W50 motor oil until oil just appears at the bottom of each transaxles' top port (approximately 2 quarts per transaxle, 4 quarts total). Install the top port lug into each transaxle as the oil level reaches the port.
11. Install and torque the top port plugs to 180 in./lbs.
12. Continue to fill the transaxles through the expansion tank until the "Full Cold" line is reached (this will take approximately 23 additional ounces).
13. Reinstall the expansion tank cap by hand. Be careful to not overtighten.
14. Proceed to the purge procedure.

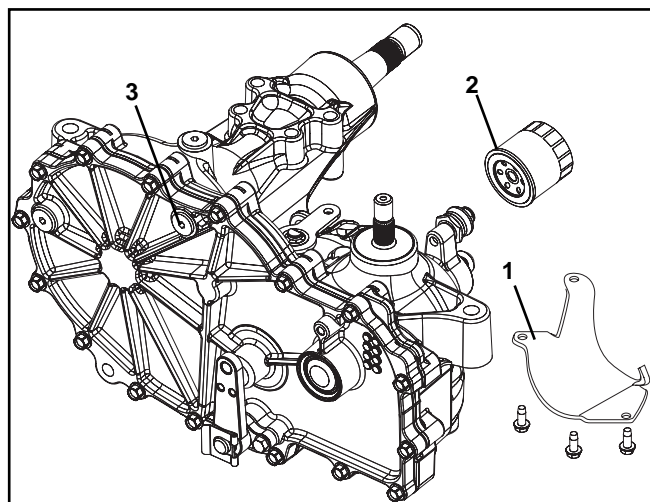

8019-010

1. Filter guard
  2. Transaxle filter
  3. Top port plug
- EZT filter change*

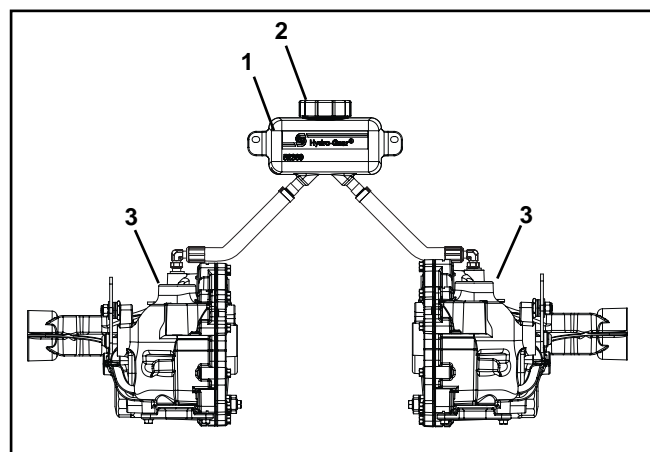

8019-012

1. Expansion tank
  2. Tank cap
  3. Transaxles
- EZT filter change*

# LUBRICATION

## Purging

Due to the effects air has on efficiency in hydrostatic drive applications, it is critical to purge the system.

These purge procedures should be implemented any time a hydrostatic system has been opened to facilitate maintenance or any additional oil has been added to the system.

Resulting symptoms in hydrostatic systems may be:

1. Noisy operation.
2. Lack of power or drive after short term operation.
3. High operation temperature and excessive expansion of oil.
4. Shortened component life.

Before starting, make sure the pump is at the proper oil level. If not, fill to the specifications outlined prior.

The following procedures are best performed with the vehicle drive wheels off the ground, then repeated under normal operating conditions.

1. Disengage the brake if activated.
2. With the bypass valve open and the engine running at fast idle, slowly move the steering control in both forward and reverse directions (5 or 6 times). As air is purged from the unit, the oil level will drop.
3. With the bypass valve closed and the engine running, slowly move the steering control in both forward and reverse directions (5 to 6 times). Check the oil level and add oil as required after stopping the engine.
4. It may be necessary to repeat Steps 2 and 3 until all the air is completely purged from the system. When the transaxle operates at normal noise levels and moves smoothly forward and reverse at normal speeds, the transaxle is considered purged.
5. After the vehicle has been used two times, the oil level should be checked while the oil is cold and adjusted accordingly.



### WARNING!

**Escaping hydraulic oil under pressure can have sufficient force to penetrate the skin, causing serious injury.**

**If injured by escaping fluid, see a doctor at once. Serious infection or reaction can develop if proper medical treatment is not administered immediately.**

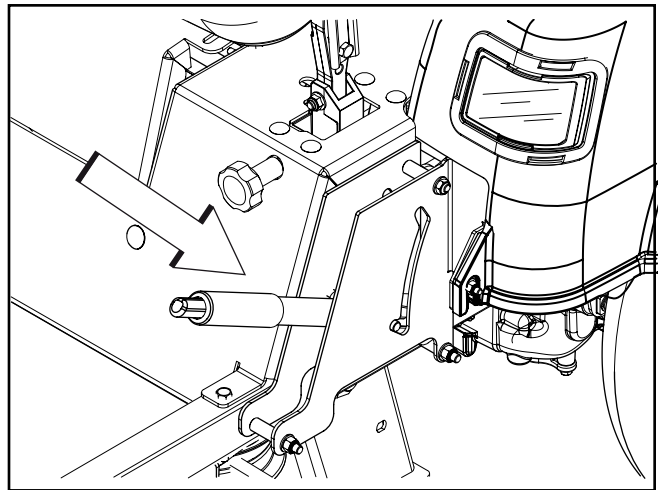

8058-020

*Disengage the parking brake*

---

# TROUBLESHOOTING

---

Problem	Cause
Engine will not start	<ul style="list-style-type: none"><li>• Blade switch is engaged.</li><li>• Steering controls are not locked in the neutral position</li><li>• Parking brake is not activated</li><li>• Battery is dead</li><li>• Contamination in the carburetor or fuel line.</li><li>• Fuel supply is closed or the shutoff valve for the fuel tank is in the wrong position</li><li>• Clogged fuel filter or fuel line</li><li>• Ignition system faulty</li></ul>
Starter does not turn the engine over	<ul style="list-style-type: none"><li>• Battery is dead</li><li>• Poor contact of the battery terminal cable connections</li><li>• Blown fuse</li><li>• Fault in the starter safety circuit. See Checking the Safety System in the "Maintenance Section"</li></ul>
Engine runs rough	<ul style="list-style-type: none"><li>• Faulty carburetor</li><li>• Choke control is pulled out with a warm engine</li><li>• Clogged fuel filter or jet</li><li>• Clogged ventilation valve on the fuel cap</li><li>• Fuel tank nearly empty</li><li>• Fouled spark plugs</li><li>• Rich fuel mixture or fuel-air mixture.</li><li>• Wrong fuel type</li><li>• Water in fuel</li><li>• Clogged air filter</li></ul>
Engine seems weak	<ul style="list-style-type: none"><li>• Clogged air filter</li><li>• Fouled spark plugs</li><li>• Carburetor incorrectly adjusted</li><li>• Air trapped in hydraulic system</li></ul>
Machine vibrates	<ul style="list-style-type: none"><li>• Blades are loose</li><li>• Blades are incorrectly balanced</li><li>• Engine is loose</li></ul>

---

# TROUBLESHOOTING

---

Problem	Cause
Engine overheats	<ul style="list-style-type: none"><li>• Clogged air intake or cooling fins</li><li>• Engine overloaded</li><li>• Poor ventilation around engine</li><li>• Defective engine speed regulator</li><li>• Too little or no oil in the engine</li><li>• Contamination in the carburetor or fuel line.</li><li>• Fouled spark plugs</li></ul>
Battery not charging	<ul style="list-style-type: none"><li>• Poor contact of the battery terminal cable connections</li><li>• Charging lead is disconnected</li></ul>
The machine moves slowly, unevenly, or not at all	<ul style="list-style-type: none"><li>• Parking brake on</li><li>• Bypass valve on pump open</li><li>• Drive belt for the transmission slack or has come off</li><li>• Air trapped in hydraulic system</li></ul>
Mower deck not engaging	<ul style="list-style-type: none"><li>• Drive belt for the mower deck has come loose</li><li>• Contact for the electromagnetic coupling has loosened</li><li>• Blade switch is faulty or has come loose from cable contact</li><li>• Blown fuse</li></ul>
Transaxle leaks oil	<ul style="list-style-type: none"><li>• Damaged seals, housing, or gaskets</li><li>• Air trapped in hydraulic system</li></ul>
Uneven mowing results	<ul style="list-style-type: none"><li>• Different air pressure in tires on the left and right sides.</li><li>• Bent blades</li><li>• Suspending for the mower deck is uneven</li><li>• Blades are dull</li><li>• Driving speed too high</li><li>• Grass is too long</li><li>• Grass collected under the mower deck</li></ul>

---

# STORAGE

---

## Winter Storage

At the end of the mowing season, the machine should be readied for storage (or if it will not be in use for longer than 30 days). Fuel allowed to stand for long periods of time (30 days or more) can leave sticky residues that can plug the carburetor and disrupt engine function.

Fuel stabilizers are an acceptable option as regards to the sticky residues that can occur during storage.

Add stabilizer to the fuel in the tank or in the storage container. Always use the mixing ratios specified by the manufacturer of the stabilizer. Run the engine for at least 10 minutes after adding the stabilizer so that it reaches the carburetor. Do not empty the fuel tank and the carburetor if you have added stabilizer



### **WARNING!**

**Never store an engine with fuel in the tank indoors or in poorly ventilated spaces where fuel vapor can come in contact with open flames, sparks, or a pilot light such as in a boiler, hot water tank, clothes dryer, etc. Handle the fuel with care. It is very flammable and can cause serious personal injury and property damage. Drain the fuel into an approved container outdoors and far away from open flame. Never use gasoline for cleaning. Use a degreaser and warm water instead.**

To ready the machine for storage:

1. Thoroughly clean the machine, especially under the mower deck. Touch up damage to the paint and spray a thin layer of oil on the underside of the mower deck to avoid corrosion.
2. Inspect the machine for worn or damaged parts and tighten any nuts or screws that may have become loose.
3. Change the engine oil; dispose of properly.
4. Empty the fuel tanks or add a fuel stabilizer. Start the engine and allow it to run until the carburetor is drained of fuel or the stabilizer has reached the carburetor.
5. Remove the spark plug and pour about a tablespoon of engine oil into the cylinder. Turn over the engine so that the oil is evenly distributed and then refit the spark plug.
6. Lubricate all grease zerks, joints, and axles.
7. Remove the battery. Clean, charge, and store the battery in a cool place, but protect it from direct cold.
8. Store the machine in a clean, dry place and cover it for extra protection.

## **Service**

When ordering spare parts, please specify the purchase year, model, type, and serial number.

Always use genuine Husqvarna spare parts.

An annual check-up at an authorized service workshop is a good way to ensure that your machine performs its best the following season.



# SCHEMATICS

- NOTE:
1. SEAT UNOCCUPIED
  2. BRAKE SWITCH IN OFF POSITION
  3. MOTION CONTROL LEVERS OUT
  4. PTO IN OFF POSITION

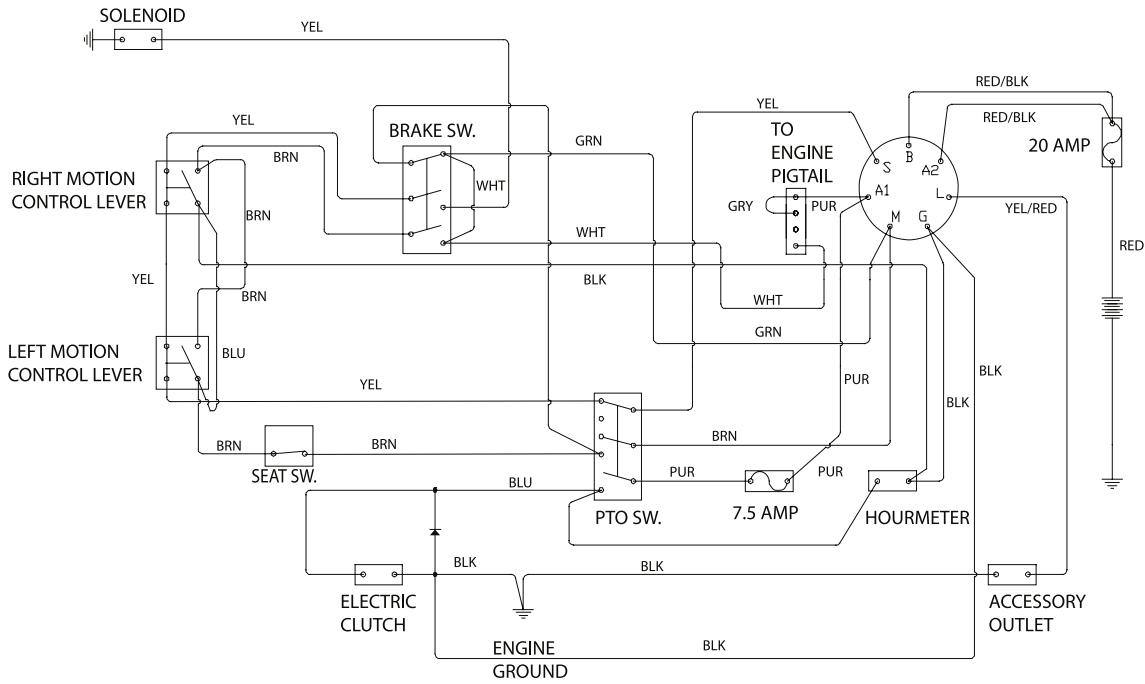

## KEY SWITCH POSITIONS

POSITION 1 - OFF

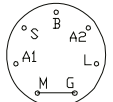

POSITION 2 - RUN1



POSITION 3 - RUN2

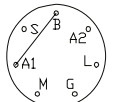

POSITION 4 - START

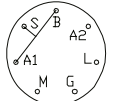

## TECHNICAL DATA

<b>EZ22 / 965880101</b>	
<b>Engine</b>	
Manufacturer	Briggs & Stratton
Type	ELS
Power	22 hp*
Lubrication	Pressure with oil filter
Oil capacity excluding filter	1.6 qts / 1.5 liters
Oil capacity including filter	1.8 qts / 1.7 liters
Engine oil (See viscosity diagram)	SAE 10W30, 10W40, 5W20, 5W30, API SF-SJ
Fuel	Min 87 octane unleaded (Max ethanol 10%, Max MTBE 15%)
Fuel tank capacity	4 gallon / 15.1 liters
Spark plugs / gap	NGK-BPR4ES .030" / 0.75 mm
Cooling	Air cooled
Air filter	Standard
Alternator	12V
Starter	Electric
<b>Transmission</b>	
Transmission	ZT2800 Hydro Gear
Speed and direction controls	Dual levers, foam gripped
Speed forward	0-7 mph / 11.3 km/h
Speed reverse	0-4 mph / 6.4 km/h
Brakes	Mechanical parking brake
Front caster tires, smooth tread	11 x 4.5-5, 4 ply
Rear tires, turf pneumatic	20 x 8-8
Tire pressure	15 PSI / 103 kPa / 1 bar

\*As rated by the engine manufacturer.

## TECHNICAL DATA

<b>EZ22 / 965880101</b>	
<b>Frame</b>	
Cutting Width	48" / 122cm
Cutting Height	1.5 - 4" / 3.8 - 10.2 cm
Uncut Circle	0
Number of Blades	3
Blade Length	16½" / 42 cm
Nose Rollers	Yes
Sprung Seat	Standard
Hinged Arm Rests	Yes
Hour Meter	Standard
Blade Engagement	Electromagnetic clutch
Deck Construction	n/a
Productivity	2.88 acres/h / 11655 m <sup>2</sup> /h
<b>Dimension</b>	
Weight	605 lbs / 274 kg
Base Machine Length	75" / 191 cm
Base Machine Height	47" / 119.4 cm
Base Machine Width	46½" / 118 cm
Overall Width, Chute Up	50" / 127 cm
Overall Width, Chute Down	68" / 160 cm
<b>Vibration</b>	
<b>Daily Exposure</b>	
Hand/Arm - A(8)	0.96 m/s <sup>2</sup>
Whole Body - A(8)	0.18 m/s <sup>2</sup>
<b>Equivalent vibration</b>	
Hand/Arm - ahv, eq	1.11 m/s <sup>2</sup>
Whole Body - ahv, eq	0.21 m/s <sup>2</sup>

# TECHNICAL DATA

## Accessories

Collection system

### Torque Specifications

Engine crankshaft bolt	50 ft/lb (67 Nm)	Standard ¼" fasteners	9 ft/lb (12 Nm)
Deck pulley bolts	150 ft/lb (203 Nm)	Standard 5/16" fasteners	18 ft/lb (25 Nm)
Lug nuts	75 ft/lb (100 Nm)	Standard 3/8" fasteners	33 ft/lb (44 Nm)
Blade bolt	90 ft/lb (122 Nm)	Standard 7/16" fasteners	52 ft/lb (70 Nm)
		Standard ½" fasteners	80 ft/lb (110 Nm)

### HEX HEAD CAP SCREWS

The torque values shown should be used as a general guideline when specific torque values are not given.

#### U.S. Standard Hardware

Grade	SAE Grade 5			SAE Grade 8		Flangelock Screw w/Flangelock Nut	
	ft./lbs	ft./lbs	Nm	ft./lbs	Nm	ft./lbs	Nm
Shank Size (Diameter in inches, fine or coarse thread)	¼	9	12	13	18		
	5/16	18	24	28	38	24	33
	3/8	31	42	46	62	40	54
	7/16	50	68	75	108		
	½	75	102	115	156		
	9/16	110	150	165	224		
	5/8	150	203	225	305		
	¾	250	339	370	502		
	7/8	378	513	591	801		
	1 1/8	782	1060	1410	1912		

\*\* Grade 5 - Minimum commercial quality (lower quality not recommended)

#### Metric Standard Hardware

Grade	Grade 8.8		Grade 10.9		Grade 12.9		
	ft./lbs	ft./lbs	Nm	ft./lbs	Nm	ft./lbs	Nm
Shank Size (Diameter in millimeters, fine or coarse thread)	M4	1.5	2	2.2	3	2.7	3.6
	M5	3	4	4.5	6	5.2	7
	M6	5.2	7	7.5	10	8.2	11
	M7	8.2	11	12	16	15	20
	M8	13.5	18	18.8	25	21.8	29
	M10	24	32	35.2	47	43.5	58
	M12	43.5	58	62.2	83	75	100
	M14	70.5	94	100	133	119	159
	M16	108	144	147	196	176	235
	M18	142	190	202	269	242	323
	M20	195	260	275	366	330	440
	M22	276	368	390	520	471	628
	M24	353	470	498	664	596	794
	M27	530	707	474	996	904	1205

---

# CONFORMITY CERTIFICATES

---

## **CE requirements**

The Declaration of Conformity is included in the literature packet.

# SERVICE JOURNAL

Action	Date, mtr reading, stamp, sign
<p><b>Delivery Service</b></p>	
1. Charge the battery.	<input type="checkbox"/>
2. Adjust the tire pressure of all wheels to 15 PSI (1 bar).	<input type="checkbox"/>
3. Mount the steering controls in the normal position.	<input type="checkbox"/>
4. Connect the contact box to the cable for the seat's safety switch.	<input type="checkbox"/>
5. Check that the right amount of oil is in the engine.	<input type="checkbox"/>
6. Adjust the position of the steering controls.	<input type="checkbox"/>
7. Fill with fuel and open the fuel shut off valve.	<input type="checkbox"/>
8. Start the engine.	<input type="checkbox"/>
9. Check that there is drive to both wheels.	<input type="checkbox"/>
10. Check the mower deck adjustment.	<input type="checkbox"/>
11. Check:	
The safety switch for the parking brake.	<input type="checkbox"/>
The safety switch for the mower deck.	<input type="checkbox"/>
The safety switch in the seat.	<input type="checkbox"/>
The safety switch in the steering controls.	<input type="checkbox"/>
Parking brake functionality.	<input type="checkbox"/>
Driving forward.	<input type="checkbox"/>
Driving backward.	<input type="checkbox"/>
Engaging the blades.	<input type="checkbox"/>
12. Check the idle speed	<input type="checkbox"/>
13. Check the engine high idle speed	<input type="checkbox"/>
14. Inform the customer about:	<input type="checkbox"/>
The need and advantages of following the service schedule.	
The need and advantages of leaving the machine for service every 300 hours.	
The effects of service and maintaining a service journal on the machine's resale value.	
Application areas for mulching.	
15. Fill in the sales papers	
	<p>Delivery service has been carried out.</p> <p>No remaining notes.</p> <p>Certified:</p>

---

# SERVICE JOURNAL

---

Action	Date, mtr reading, stamp, sign
<p><b>After the First 5-8 Hours</b></p> <p>1. Change engine oil.</p>	<input data-bbox="1034 360 1066 398" type="checkbox"/>

# SERVICE JOURNAL

Action	Date, mtr reading, stamp, sign
<p><b>25-Hour Service</b></p> <ol style="list-style-type: none"><li>1. Check the engine air filter.</li><li>2. Sharpen/Replace mower blades if required.</li><li>3. Check the tire pressures.</li><li>4. Check battery with cables.</li><li>5. Lubricate according to lubrication chart.</li><li>6. Check/clean the engine's cooling air intake.</li><li>7. Clean the air cleaner's prefilter (foam).</li></ol>	<p><input type="checkbox"/></p> <p><input type="checkbox"/></p> <p><input type="checkbox"/></p> <p><input type="checkbox"/></p> <p><input type="checkbox"/></p> <p><input type="checkbox"/></p> <p><input type="checkbox"/></p>



# SERVICE JOURNAL

Action	Date, mtr reading, stamp, sign
<p><b>50-Hour Service</b></p> <ol style="list-style-type: none"><li>1. Perform the 25-hour service.</li><li>2. Clean/replace the air cleaner's filter cartridge (paper filter) (shorter intervals for dusty operating conditions).</li><li>3. Change engine oil.</li><li>4. Lubricate according to lubrication chart.</li><li>5. Check/adjust the parking brake.</li><li>6. Change hydraulic pump oil and filter.</li></ol>	<p><input type="checkbox"/></p> <p><input type="checkbox"/></p> <p><input type="checkbox"/></p> <p><input type="checkbox"/></p> <p><input type="checkbox"/></p> <p><input type="checkbox"/></p>

# SERVICE JOURNAL

Action	Date, mtr reading, stamp, sign
<p><b>100-Hour Service</b></p> <ol style="list-style-type: none"><li>1. Perform the 25-hour service.</li><li>2. Perform the 50-hour service.</li><li>3. Change the engine oil filter.</li><li>4. Clean/replace the spark plugs.</li><li>5. Replace the fuel filter.</li><li>6. Check V-belts.</li><li>7. Check tighten caster wheel axle bolts (every 200 hours).</li><li>8. Change the air filter's paper cartridge.</li><li>9. Change hydraulic pump oil and filter. (200 hours)</li></ol>	<p><input type="checkbox"/></p> <p><input type="checkbox"/></p> <p><input type="checkbox"/></p> <p><input type="checkbox"/></p> <p><input type="checkbox"/></p> <p><input type="checkbox"/></p> <p><input type="checkbox"/></p> <p><input type="checkbox"/></p> <p><input type="checkbox"/></p>

# SERVICE JOURNAL

Action	Date, mtr reading, stamp, sign
<p><b>300-Hour Service</b></p> <ol style="list-style-type: none"><li>1. Perform the 25-hour service.</li><li>2. Perform the 50-hour service.</li><li>3. Perform the 100-hour service.</li><li>4. Check/adjust the mower deck.</li><li>5. Clean the combustion chamber and grind the valve seats.</li><li>6. Check the engine valve clearance.</li><li>7. Replace the air cleaner's prefilter (foam).</li></ol>	<p><input type="checkbox"/></p> <p><input type="checkbox"/></p> <p><input type="checkbox"/></p> <p><input type="checkbox"/></p> <p><input type="checkbox"/></p> <p><input type="checkbox"/></p> <p><input type="checkbox"/></p>

# SERVICE JOURNAL

Action	Date, mtr reading, stamp, sign
<p><b>At Least Once Each Year</b></p> <ol style="list-style-type: none"><li>1. Clean the engine's cooling air intake (25 hours).</li><li>2. Replace the air cleaner's pre-filter (foam) (300 hours).</li><li>3. Replace the air filter's paper cartridge.</li><li>4. Change the engine oil (50 hours).</li><li>5. Replace the engine oil filter (100 hours).</li><li>6. Check/adjust the cutting height.</li><li>7. Check/adjust the parking brake (50 hours).</li><li>8. Clean/change the spark plugs (100 hours).</li><li>9. Change the fuel filter (100 hours).</li><li>10. Check the engine valve clearance.</li></ol>	<input type="checkbox"/> <input type="checkbox"/> <input type="checkbox"/> <input type="checkbox"/> <input type="checkbox"/> <input type="checkbox"/> <input type="checkbox"/> <input type="checkbox"/> <input type="checkbox"/> <input type="checkbox"/>



---

# SERVICE JOURNAL

---

Action	Date, mtr reading, stamp, sign



115 15 79-26



2009-04-29