

Operator and Parts Manual

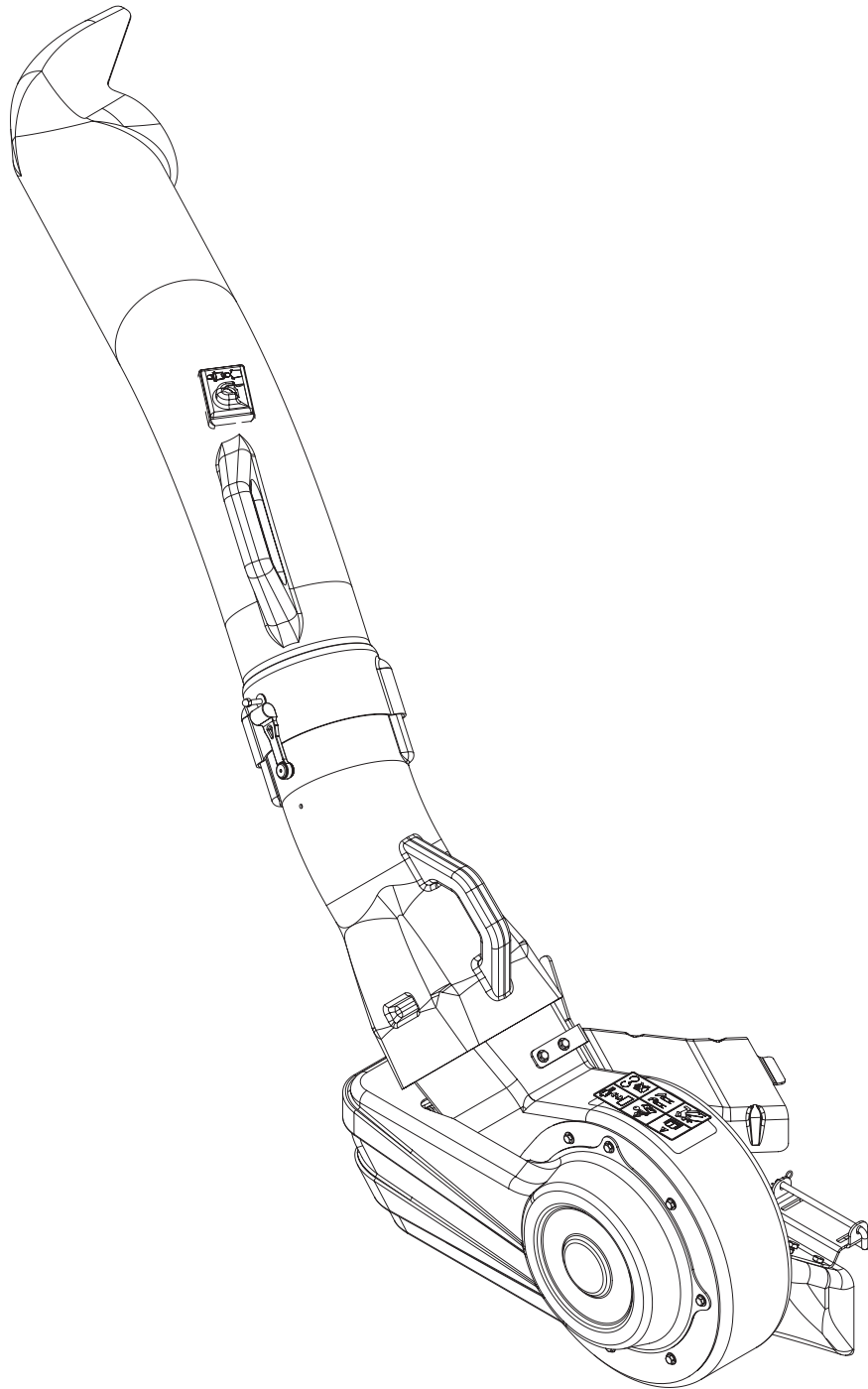

Blower Kit Collection System

539 13 23-98 MZ

(966 00 45-01 Combined with 960 73 00-19 EZ)

TABLE OF CONTENTS

SAFETY RULES.....	4
CARTON CONTENTS.....	7
ASSEMBLY	8
OPERATION.....	16
CUSTOMER RESPONSIBILITIES	17
PARTS	18

CONGRATULATIONS on your purchase of a new collection system. It has been designed, engineered and manufactured to give you the best possible dependability and performance. Should you experience any problem you cannot easily remedy, please contact your nearest authorized service center/ department. They have competent, well-trained technicians and the proper tools for service and repairs. Please read and retain this manual. The instructions will enable you to assemble and maintain your collection system properly. Always observe the "SAFETY RULES".

KNOW YOUR BLOWER SYSTEM

READ THIS OPERATION MANUAL AND SAFETY RULES BEFORE ASSEMBLING OR OPERATING YOUR BLOWER SYSTEM. Compare the illustrations with the carton contents to familiarize yourself with the parts before starting the assembly. Study the operating instructions and safety precautions thoroughly to insure proper functioning of your Grass Catcher and to prevent injury to yourself and others. Save this manual for future reference.



WARNING

The operation of any mower can result in foreign objects thrown into the eyes, which can result in severe eye damage. **ALWAYS** wear safety glasses or eye shields before starting your mower and while mowing. We recommend a wide vision safety mask for over the spectacles or standard safety glasses.

SAFETY RULES



SAFE OPERATION PRACTICES FOR RIDE-ON MOWERS



DANGER !

THIS CUTTING MACHINE IS CAPABLE OF AMPUTATING HANDS AND FEET AND THROWING OBJECTS. FAILURE TO OBSERVE THE FOLLOWING SAFETY INSTRUCTIONS COULD RESULT IN SERIOUS INJURY OR DEATH.

I. GENERAL OPERATION

- Read, understand and follow all instructions in the manual and on the machine before starting.
- Only allow responsible adults, who are familiar with the instructions, to operate the machine.
- Clear the area of objects such as rocks, stones, toys, wire etc., which could be picked up and thrown by the blades.
- Be sure the area is clear of all people and pets before mowing. Stop the machine if anyone enters the area.
- Never carry passengers or children even with blades off.
- Do not mow in reverse unless absolutely necessary. Always look down and behind before and while backing.
- Be aware of the mower discharge direction and do not direct it towards anyone. Do not operate the mower without either the entire grass catcher or the guard in place.
- Slow down before turning.
- Never leave the machine unattended when the engine is running. Always turn off the blades, set the parking brake, stop the engine and remove the key before leaving the machine.
- Turn off blades when not mowing.
- Stop engine before removing grass catcher or unclogging chute.
- Mow only in daylight or good artificial light.
- Do not operate the machine while under the influence of alcohol or drugs.
- Watch out for traffic when operating near or crossing roadways.
- Use extra care when loading and unloading the machine onto a trailer or truck.

- Data indicates that operators, age 60 years and above, are involved in a large percentage of riding mower-related injuries. These operators should evaluate their ability to operate the riding mower safely enough to protect themselves and others from serious injury.
- **DO NOT** operate mower with grass catcher, unless the front weights are installed.
- Keep machine free of grass, leaves or other debris buildup which can touch hot exhaust/engine parts and burn. Do not allow the mower deck to plow leaves or other debris which can cause buildup to occur. Clean any oil or fuel spillage before operating or storing the machine. Allow machine to cool before storage.

II. SLOPE OPERATION

Slopes are a major factor related to loss-of-control and tip-over accidents, which can result in severe injury or death. All slopes require extra caution. If you cannot back up the slope or if you feel uneasy on it, do not mow it.

DO

- Mow up and down slopes (10° Max.), not across.
- Remove obstacles such as rocks, tree limbs, etc.
- Watch for holes, ruts, or bumps. Uneven terrain could overturn the machine. **Tall grass can hide obstacles.**
- Use slow speed. Choose a low speed so that you will not have to stop while on the slope.
- Use extra care with grass catchers or other attachments. These can change the stability of the machine.
- Keep all movement on the slopes **slow** and **gradual**. Do not make sudden changes in speed or direction.
- Avoid starting or stopping on a slope. If tires lose traction, disengage the blades and proceed slowly **straight** down the slope.

SAFETY RULES



SAFE OPERATION PRACTICES FOR RIDE-ON MOWERS



DO NOT

- **Do not** turn on slopes unless necessary, and then, turn slowly and gradually downhill, if possible.
- **Do not** mow near drop-off, ditches, or embankments. The mower could suddenly turn over if a wheel is over the edge of a cliff or ditch, or if an edge caves in.
- **Do not** mow on wet grass. Reduced traction could cause sliding.
- **Do not** try to stabilize the machine by putting your foot on the ground.
- Use extra care in handling gasoline and other fuels. They are flammable and vapors are explosive.
 - Use only an approved container.
 - Never remove gas cap or add fuel with the engine running.
 - Allow engine to cool before refueling.
 - Do not smoke.
 - Never refuel the machine indoors.
 - Never store the machine or fuel container inside where there is an open flame, such as a water heater.

III. CHILDREN

Tragic accidents can occur if the operator is not alert to the presence of children. Children are often attracted to the machine and the mowing activity.

Never assume that children will remain where you last saw them.

- **NEVER allow children to operate the machine.**
- Keep children out of the mowing area and under the watchful care of another responsible adult.
- Be alert and turn off the machine if children enter the area.
- Before and when backing, look behind and **down** for small children.
- Never carry children. They may fall off and be seriously injured or interfere with safe machine operation.
- Use extra care when approaching blind corners, shrubs, trees, or other objects that may obscure vision.

IV. SERVICE

- The operation of any mower can result in foreign objects thrown into the eyes, which can result in severe eye damage. Always wear safety glasses or eye shields while operating your mower or performing any adjustments or repairs. We recommend a wide vision safety mask over spectacles or standard safety glasses.
- Never run a machine inside a closed area.
- Keep nuts and bolts, especially blade attachment bolts, tight and keep equipment in good condition.
- Never tamper with safety devices. Check their proper operation regularly.
- Keep machine free of grass, leaves, or other debris buildup. Clean oil or fuel spillage. Allow machine to cool before storing.
- Stop and inspect the equipment if you strike an object. Repair, if necessary, before restarting.
- Never make adjustments or repairs with the engine running.
- Grass catcher components are subject to wear, damage, and deterioration, which could expose moving parts or allow objects to be thrown. Frequently check components and replace with manufacturer's recommended parts, when necessary.
- Mower blades are sharp and can cut. Wrap the blade(s) or wear gloves, and use extra caution when servicing them.
- Check brake operation frequently. Adjust and service as shown in the Operator's Manual.

SAFETY RULES



SAFE OPERATION PRACTICES FOR RIDE-ON MOWERS



- **NEVER allow children to operate the machine.**
- Be sure the area is clear of other people before mowing. Stop machine if anyone enters the area.
- Never carry passengers or children even with the blades off.
- Do not drive in reverse unless absolutely necessary. Always look down and behind before and while backing.
- Never carry children. They may fall off and be seriously injured or interfere with safe machine operation.
- Keep children out of the mowing area and under the watchful care of another responsible adult.
- Be alert and turn machine off if children enter the area.
- Before and when backing, look behind and down for small children.
- Mow up and down slopes (10° Max), not across.
- Remove obstacles such as rocks, tree limbs, etc.
- Watch for holes, ruts, or bumps. Uneven terrain could overturn the machine. Tall grass can hide obstacles.
- Use a slow speed while on slope or hill.
- Avoid starting or stopping on a slope. If tires lose traction, disengage the blades and proceed slowly straight down the slope.
- If machine stops while going uphill, disengage blades, shift into reverse and back down slowly.
- Do not turn on slopes unless necessary, and then, turn slowly and gradually downhill, if possible.



CAUTION

In order to prevent accidental starting when setting up, transporting, adjusting or making repairs, always disconnect spark plug wire and place wire where it cannot contact spark plug.



WARNING

DO NOT tow any trailers, etc. with this mower. They may jackknife or over turn causing damage to the mower and possibly serious injury to the operator.



WARNING

Engine exhaust, some of its constituents, and certain vehicle components contain or emit chemicals known to the State of California to cause cancer and birth defects or other reproductive harm.



WARNING

Battery posts, terminals and related accessories contain lead and lead compounds, chemicals know to the State of California to cause cancer and birth defects or other reproductive harm. Wash hands after handling.



CAUTION

Look for this symbol to point out important safety precautions. It means
**CAUTION! BECOME ALERT!
YOUR SAFETY IS INVOLVED.**

UNPACKING INSTRUCTIONS

- Remove all parts and packing materials from carton.

TOOLS REQUIRED

- $\frac{7}{16}$ " Wrench or ratchet and socket
- $\frac{1}{2}$ " Wrench or ratchet and socket
- $\frac{7}{8}$ " Socket
- Torque Wrench
- Phillips Head Screwdriver
- Hacksaw
- Pliers
- Drill and $\frac{3}{8}$ " drill bit - 3 bag system only

CONTAINER CONTENTS

- Blower Assembly
- Belt Shield
- Mounting Bracket
- Weight (not included in 52" Kit 539 13 23-98)
- Drive Pulley
- Belt
- Bag of Hardware

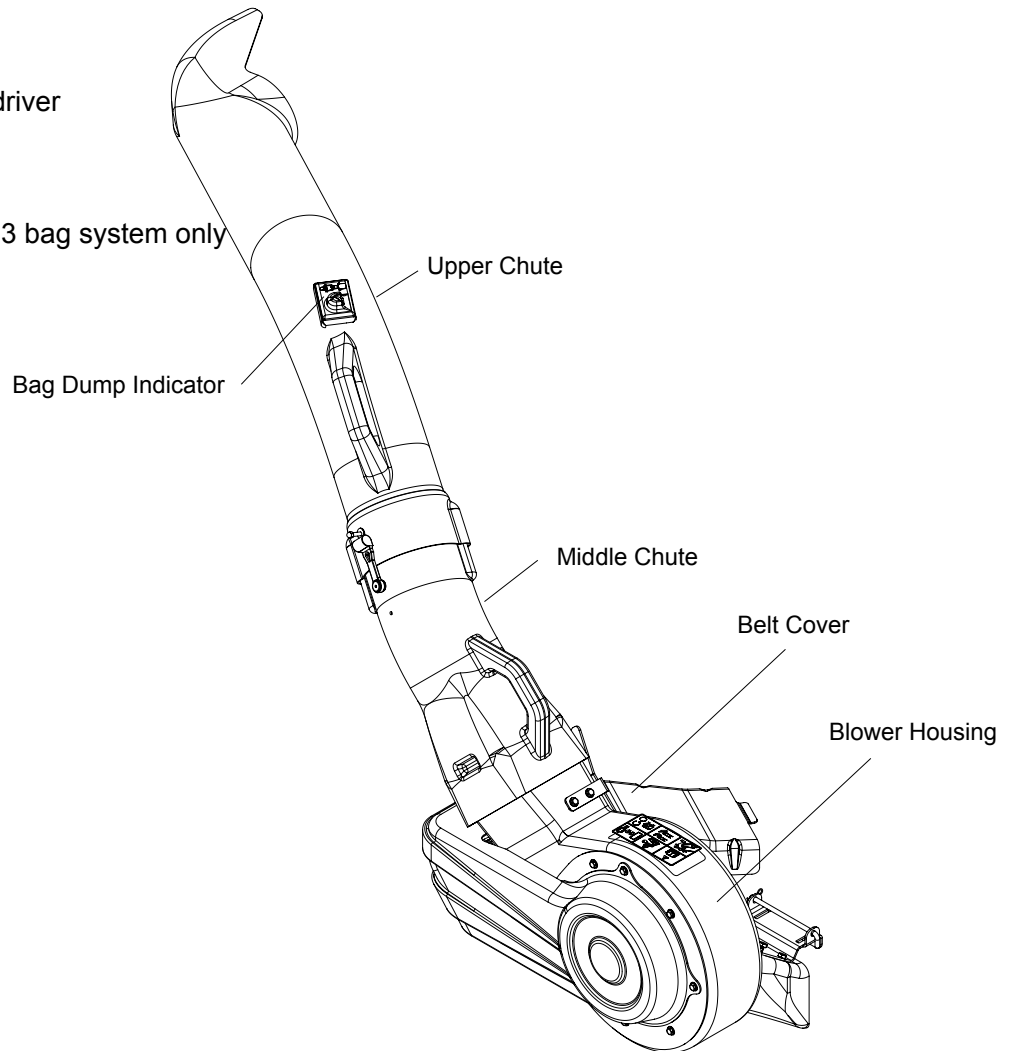

NOTE: When right hand (R.H.) and left hand (L.H.) are mentioned in this manual, it means when you are seated on the mower in the operator's position.



CAUTION

BEFORE ASSEMBLING GRASS CATCHER TO MOWER:

- **Set parking brake.**
- **Place motion control levers in "NEUTRAL" position.**
- **Turn ignition key "OFF" and remove key.**
- **Make sure the blades and all moving parts have completely stopped.**
- **Disconnect spark plug and place wire where it cannot come in contact with plug.**

ASSEMBLY

1 INSTALLING DRIVE PULLEY

1. Remove the discharge chute from the deck.
(Deck configuration will vary by size and model)
2. Lower deck to the lowest cutting position.
3. Remove the right hand (discharge side) belt cover from the deck.
4. Relieve the tension from the deck belt and remove from the center deck pulley.
(See Operator's Manual if necessary)

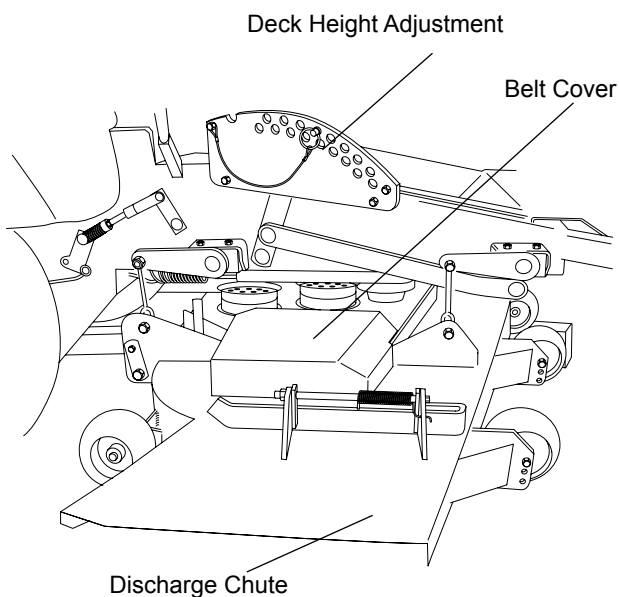

5. Remove the nut that secures the right hand deck pulley to the spindle.
6. Install drive pulley included in collection system kit on top of the current deck pulley.
7. Reinstall the nut on the spindle and torque to 55-75 ft/lbs.
8. Reinstall the deck belt.

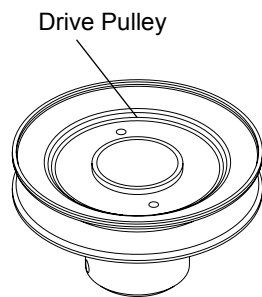

2 TRIMMING BLOWER (52" decks only)

1. Place blower assembly on secure table or stable surface.
2. Remove the bolts securing the rear mount bracket.
3. Using the hacksaw, trim the blower housing along the recessed grooves.
4. Reinstall the rear mount bracket with previously removed bolts.

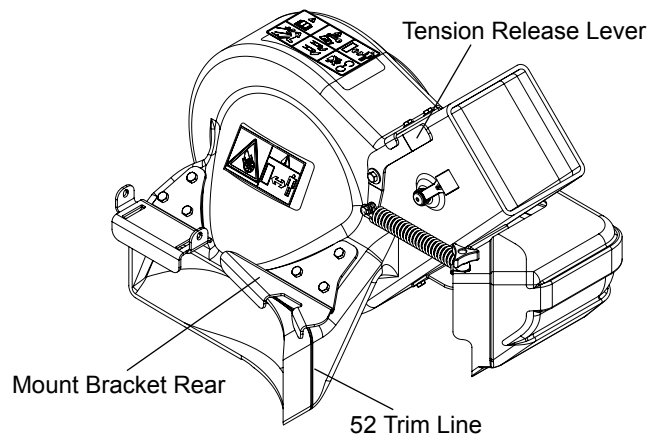

ASSEMBLY

3 MOUNTING BLOWER ASSEMBLY

1. Position blower over the discharge tabs on the deck and set blower onto the deck.
2. Be sure the blower is sitting flush against the outside of the deck.

NOTE: The rear mount bracket is designed to fit all deck sizes.

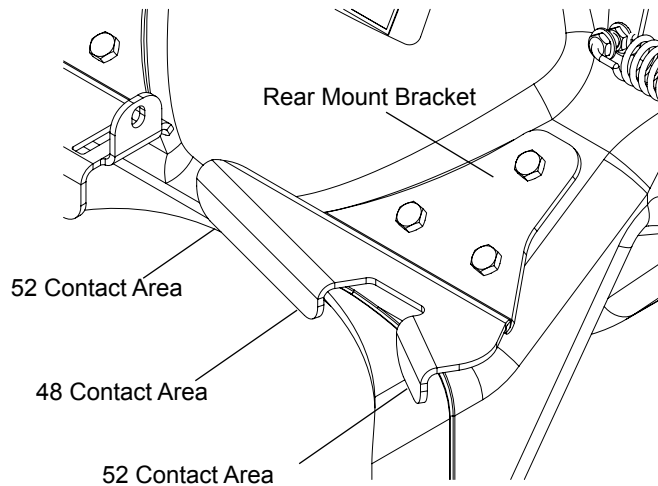

3. Install the front mount bracket to the deck with the pin and hairpin cotter supplied with the kit.

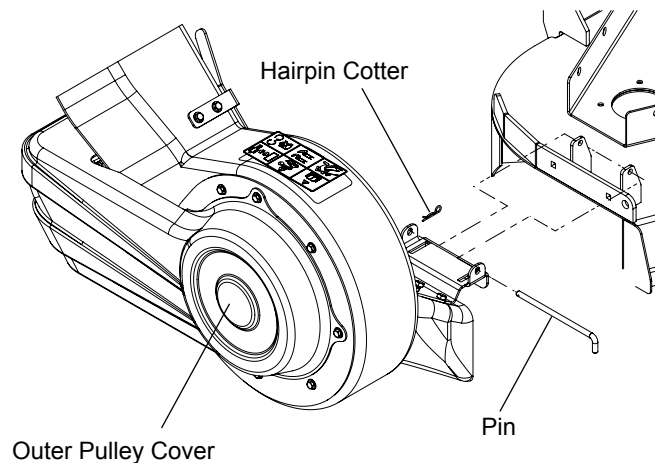

4 INSTALLING DRIVE BELT

1. Make sure the tension release lever is forward or disengaged.
2. Place the belt over the pulley on the deck. Refer to illustration for proper routing.
3. Move the tension release arm to the rear and engage in the latch.

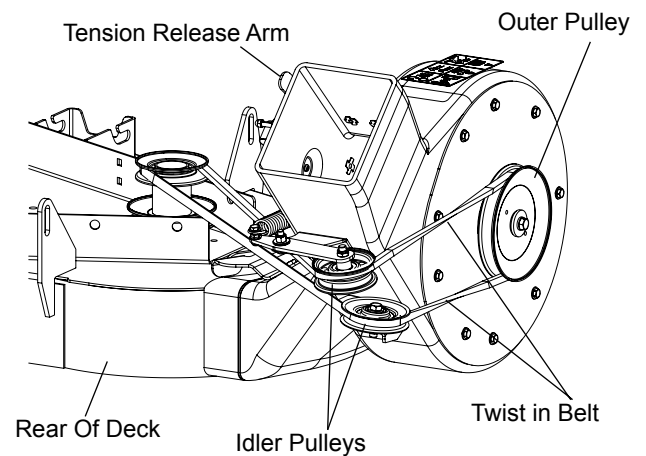

ASSEMBLY

5 TRIMMING BELT COVER (48" decks only)

1. Using the hacksaw, trim the belt cover along the dashed line.

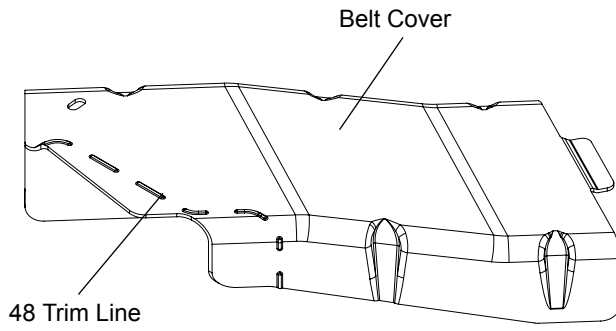

6 INSTALLING BELT COVERS

1. Place the deck belt shield on the deck over the drive pulley and secure with hardware removed from steel belt shield.
2. Place retainer on the outer pulley cover.
3. Align the tab end of the belt cover into the slot on the deck belt shield and the other end over the end of the outer pulley cover.
4. Secure with knob.

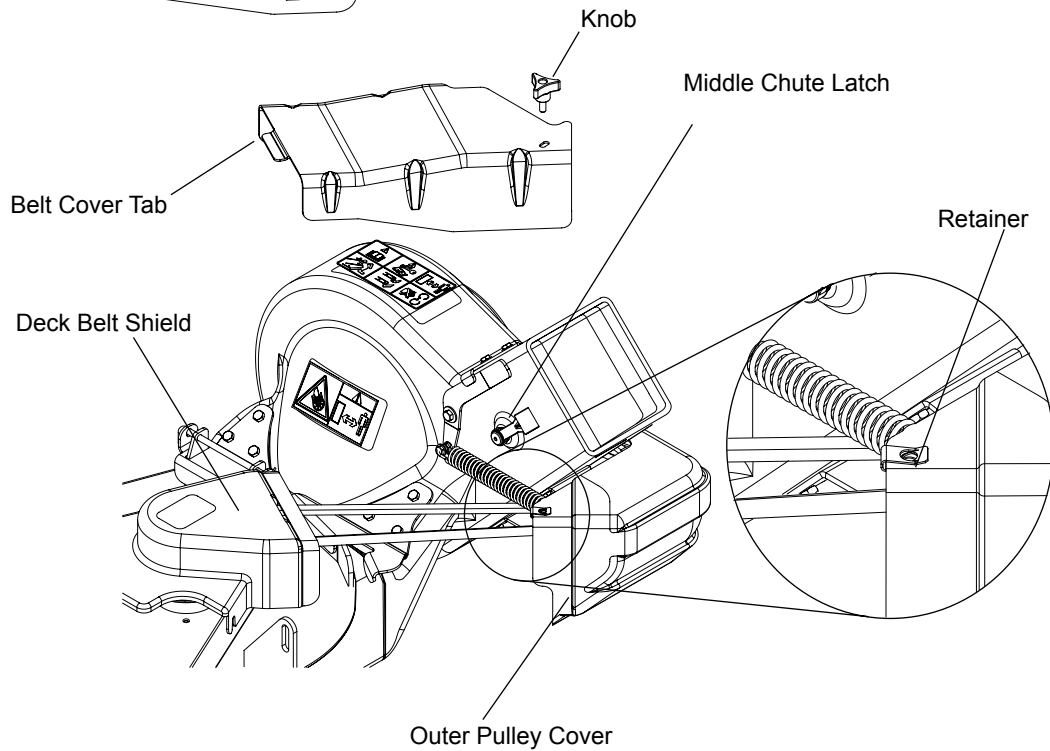

ASSEMBLY

7 TRIMMING MIDDLE CHUTE (48" decks only)

1. Using the hacksaw, trim along the dashed line.
2. Locate the middle chute, flat washer, hood latch, weld nut, lock washer and machine screw from kit.
3. Install in the appropriate hole at the upper end of the middle chute, according to deck size.

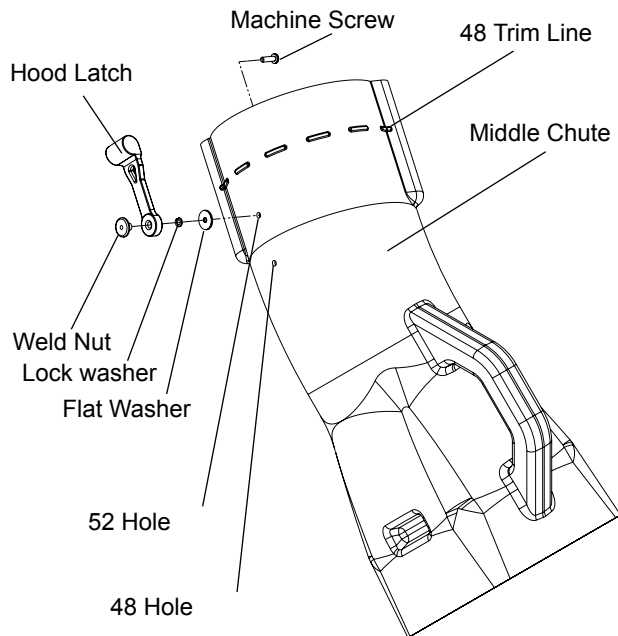

8 INSTALLING MIDDLE CHUTE

1. Place middle chute over the top end of the blower assembly.
2. Latch middle chute to blower assembly.

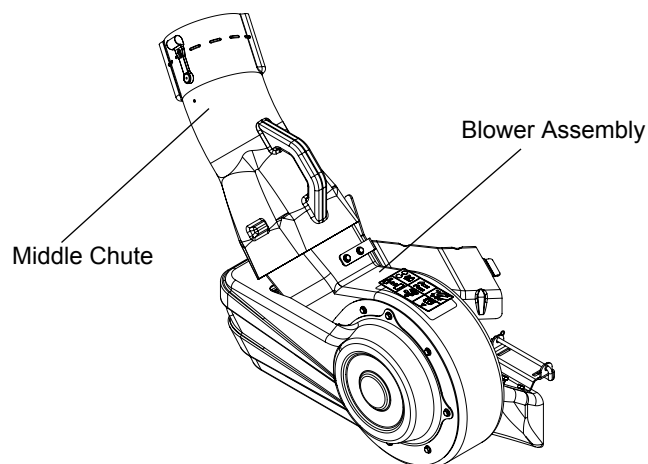

9 INSTALLING BAGGER MOUNT 2 Bin Collector

1. Remove the top right mount strap from the rear of the mower and save hardware.
2. Remove the right rear skid plate bolt and the lower right mount strap bolt from the mower and save hardware.

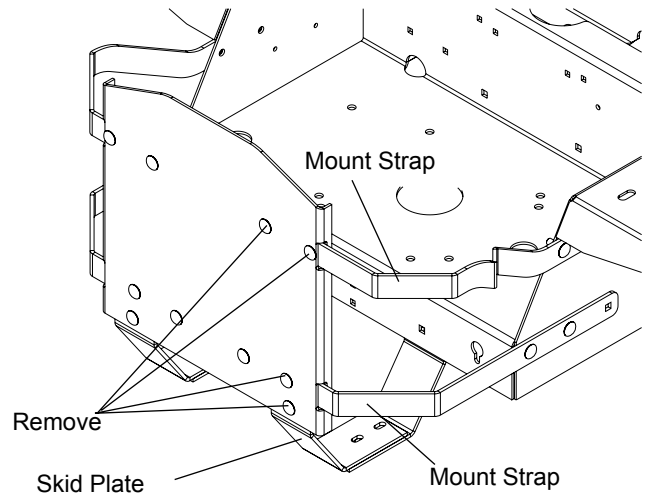

3. Place the bagger mount bracket against the rear of the engine guard, reinstall the upper right mount strap and secure with 1" carriage bolts and previously removed nuts.
4. Tighten all hardware.

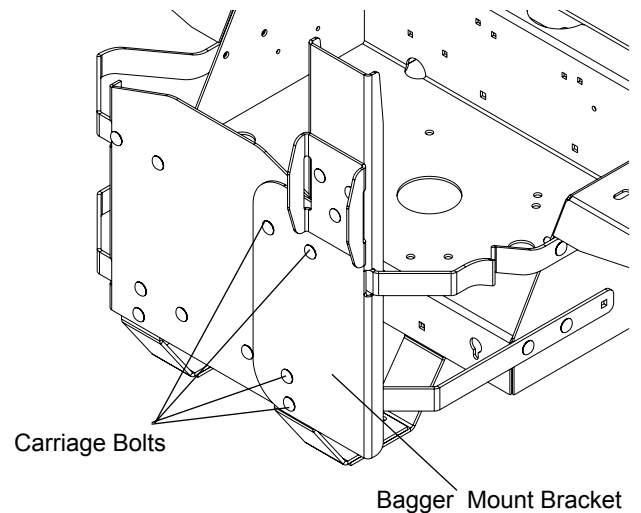

ASSEMBLY

10 INSTALLING BAGGER MOUNT 3 Bin Collector

1. Remove the four carriage bolts indicated from the rear guard.

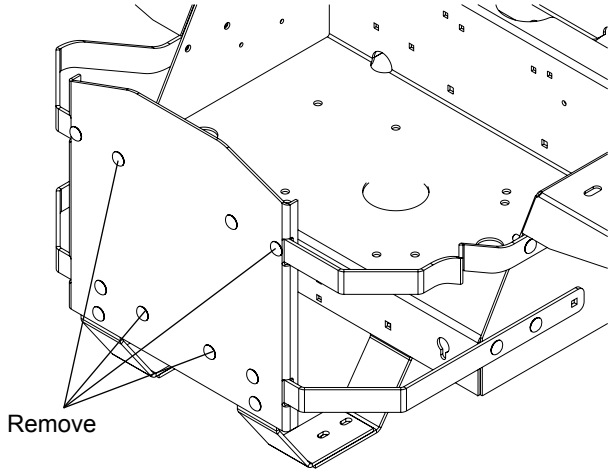

2. Install the bagger mount tube from the mount kit.

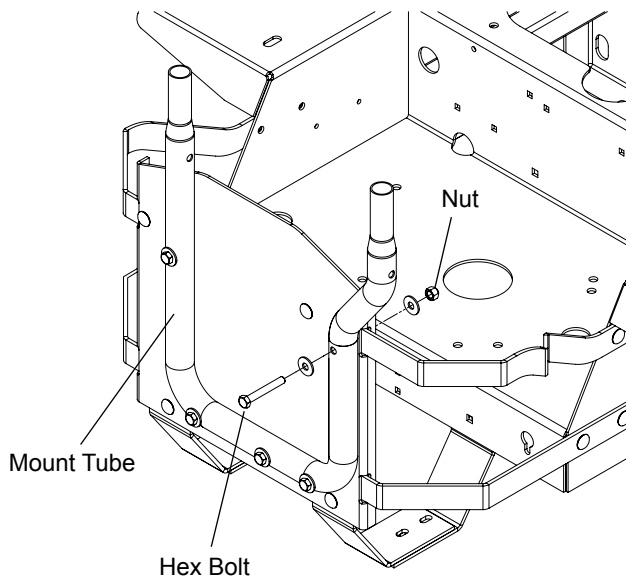

3. Remove the front carriage bolts securing the top mount straps to the frame.
4. Install kit mount straps between the mount tube and frame as shown in the illustration. The front side of the kit mount straps should be on the inside of the mower frame.

NOTE: Models with vertically mounted muffler will not use the right mount strap.

3. Tighten all hardware.

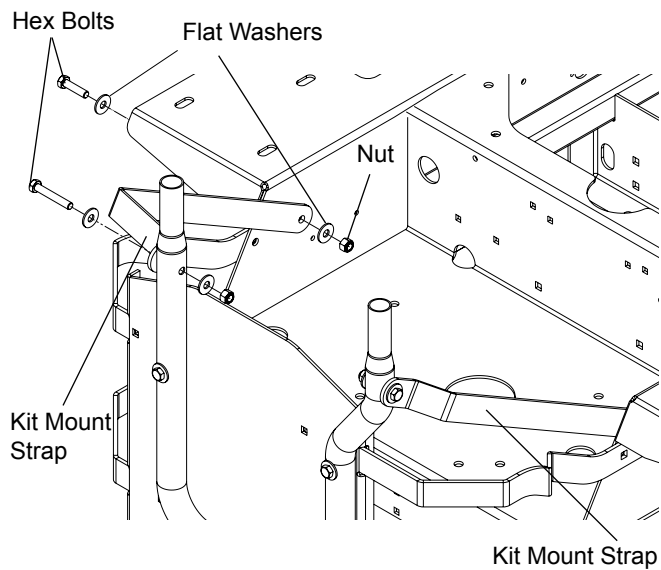

Vertical Mount Mufflers

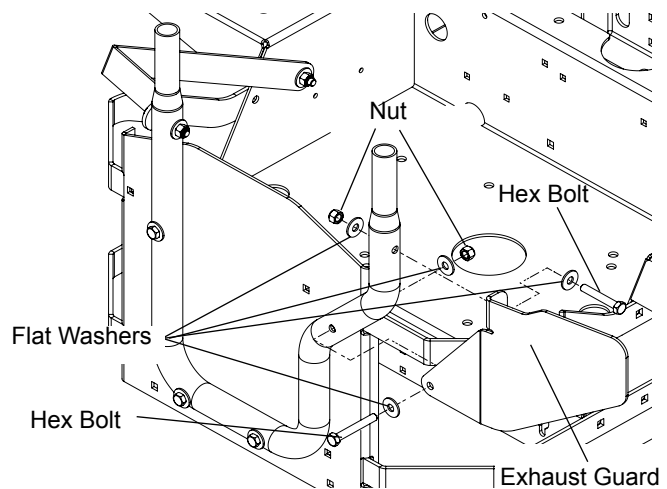

1. Install exhaust guard to right side of mount as shown.
 2. Secure with hex bolts, washers and hex nuts.
- NOTE: Models with vertically mounted muffler will not use the right mount strap.*

ASSEMBLY

11 INSTALLING CHUTE SUPPORT 3 Bin System only

1. Position upper chute support against bagger inlet, flush at outer edges. See Illustration.
2. Using support as a template, drill two $\frac{3}{8}$ holes into bagger hood.
3. Secure upper chute support to hood with hex bolts, washers and nyloc nuts.

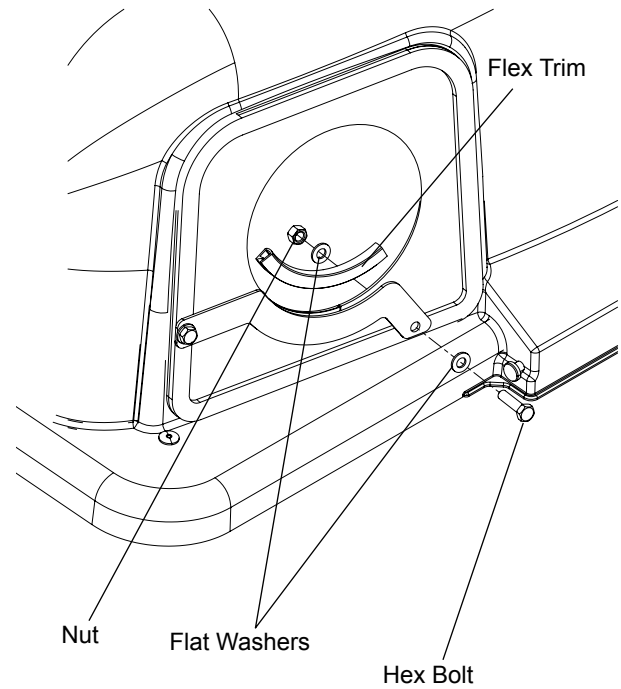
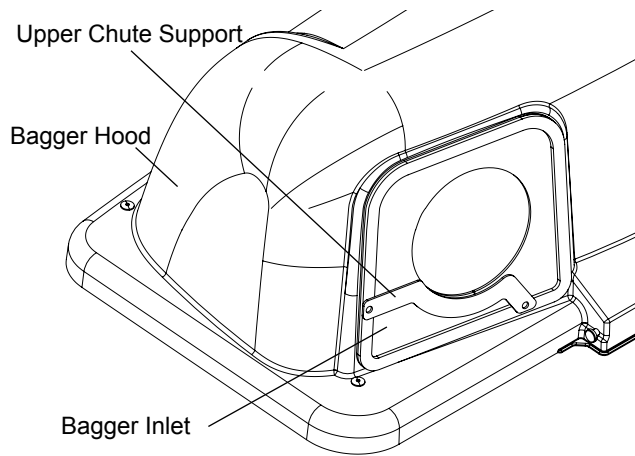

ASSEMBLY

12 INSTALLING WEIGHT KITS

Units with one weight plate

1. Bolt one (1) weight plate and two (2) weight brackets together using four (4) 1¼" bolts and four (4) nuts.
2. Slide both weight brackets over the front tube on the frame. Be sure to position in the center of the frame.
3. Secure with four (4) 2¾" bolts and four (4) nuts.

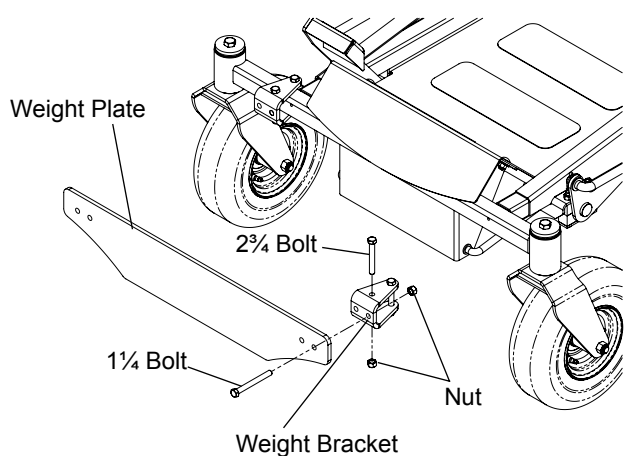

Units with two or more weight plates

1. Bolt weight plates to weight brackets using four (4) 1¾" bolts and four (4) nuts.
2. Slide both weight brackets over the front tube on the frame. Be sure to position in the center of the frame.
3. Secure with four (4) 2¾" bolts and four (4) nuts.

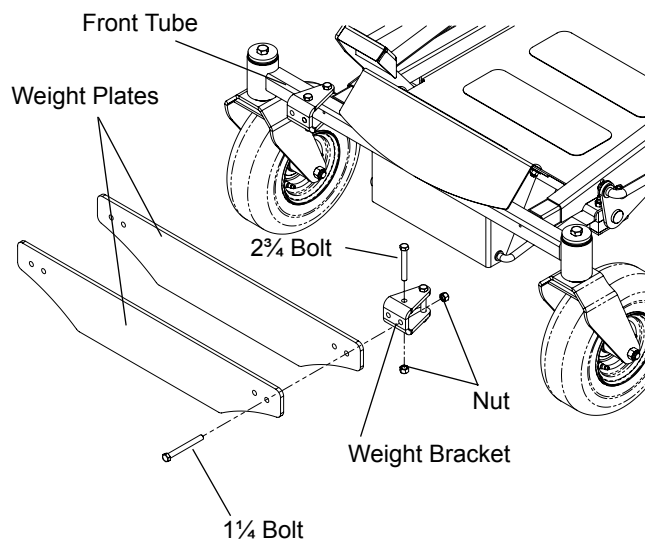

Collection System Size	Number of Weights
48" 3 Bin	3
52" 3 Bin	2

 **CAUTION**

DO NOT operate mower with grass catcher, unless the front weights are installed.

N

ASSEMBLY

13 MOUNTING COVER ASSEMBLY TO SUPPORT ASSEMBLY (2 BAG SYSTEM)

NOTE: For ease of assembly, you may wish assistance from another person for mounting the cover assembly to mower.

1. Position cover assembly on ground behind mower.
2. Lift and rotate cover to align the cover bracket with hanger bracket and slide the cover down until secure.

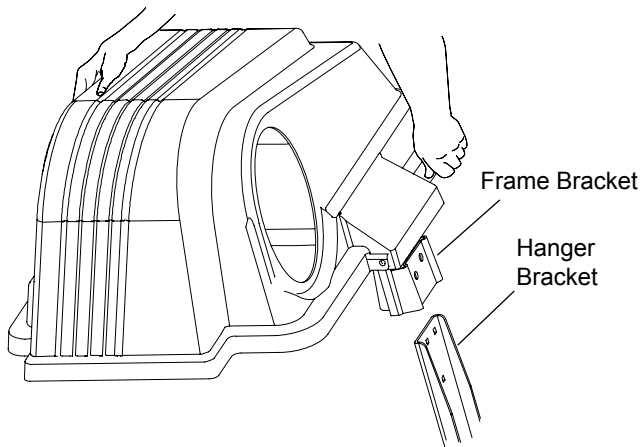

14 MOUNTING COVER ASSEMBLY TO SUPPORT ASSEMBLY (3 BAG SYSTEM)

NOTE: For ease of assembly, you may wish assistance from another person for mounting the cover assembly to mower.

1. Position cover assembly on ground behind mower.
2. Lift and rotate cover to align the cover brackets with support assembly tubes.
3. Slide the cover down over the support tubes until secure.

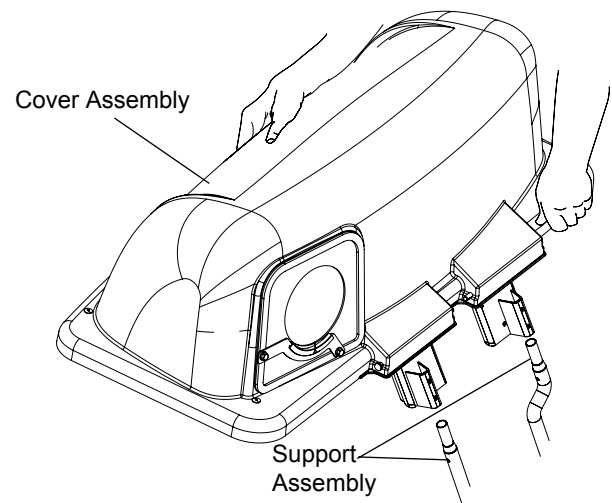

OPERATION

TIPS FOR IMPROVED BAGGING

Follow the mower operation instructions in your mower operator's manual.

When operating your grass catcher on a lawn where grass and leaf bagging equipment has not been used, you are picking up thatch and debris that has accumulated for long periods of time. The amount collected and the total time of operation may be greater than you will experience with regular use of your grass catcher.

- Always run throttle at full speed when bagging.
- Select a speed low enough to give good mower cutting performance, good quality cut and good bagging performance.
NOTE: It may be necessary to overlap width of cut to suit your conditions.
- If grass is extremely tall, it should be mowed twice. The first time relatively high, the second time to desired height.
- Use left hand side of mower for trimming.
- Plastic trash bags (3.0 mil, 30 gallon) can be inserted inside grass catcher containers for ease of debris disposal. To remove the plastic trash bags when full:
 - a. Disengage blades, shift into neutral, engage the parking brake and stop the engine.
 - b. Unlatch and raise cover.
 - c. Remove one container at a time by grasping container handles and pulling toward the rear, off of the tube rails.
 - d. With the container resting on the ground, close and secure the top of the plastic lawn bag.
 - e. Tip the container on its side and slide the filled bag from the container.
 - f. Install a new plastic lawn bag with the edges of the bag draped over upper lip of the Container (for replacement bags refer to REPLACEMENT PARTS).
 - g. Repeat for other container.
 - h. Reinstall containers making sure right container overlaps left container at center supports.
 - i. Close cover and secure latches over center support tubes.

- Avoid cutting wet grass or in the morning while the dew is still heavy. Grass clippings collected under these conditions tend to be sticky and adhere to the walls of the flow path causing clogging.
- If the grass catcher fails to pick up cut grass or leaves, it is an indication that clogging has occurred in the system or that the grass catcher containers are full.
 - a. Disengage blades, place motion control levers in neutral position.
 - Unlatch and raise cover.
 - Slide out containers and dispose of clippings.
 - Replace containers, close cover, and latch.
 - b. Unlatch chutes and check for clogging.
 - Remove all debris in chute.
 - Reassemble and latch chutes.



CAUTION

- **DO NOT operate mower with grass catcher partially installed.**
- **Disengage blades and stop engine before leaving mower seat to empty containers, unclogging chutes, etc.**
- **Close cover before starting.**
- **Disengage mower blades when crossing driveways or gravel surfaces and other areas where thrown objects could be a hazard.**
- **DO NOT attempt to vacuum cans or other potentially hazardous projectiles.**

CUSTOMER RESPONSIBILITIES

GENERAL RECOMMENDATIONS

Always observe safety rules when performing any maintenance.

- Before each use check for loose fasteners.
- Clean unit thoroughly after each use.

BLADE CARE

For best results mower blades must be kept sharp. Replace bent or damaged blades.

- See BLADE CARE instructions in your mower operator's manual.



CAUTION

BEFORE PERFORMING MAINTENANCE, SERVICE OR ADJUSTMENTS:

- Set parking brake.
- Place motion control levers in "NEUTRAL" position.
- Place clutch control in "DISENGAGED" position.
- Turn ignition key to "OFF" position.
- Make sure blades and all moving parts have completely stopped.
- Disconnect spark plug wire(s) from spark plug(s) and place wire where it cannot come in contact with plug.

STORAGE

When grass catcher is to be stored for a period of time, clean it thoroughly, remove all dirt, grass, leaves, etc. Store in a clean, dry place.



CAUTION

Do not leave grass in bagger containers. Empty containers after each use and before storing. Failure to do so may result in spontaneous combustion which could develop into a fire.



CAUTION

Grass catcher components are subject to wear, damage and deterioration, which could expose moving parts or allow objects to be thrown. Frequently check components and replace with manufacturer's recommended parts, when necessary.

PARTS

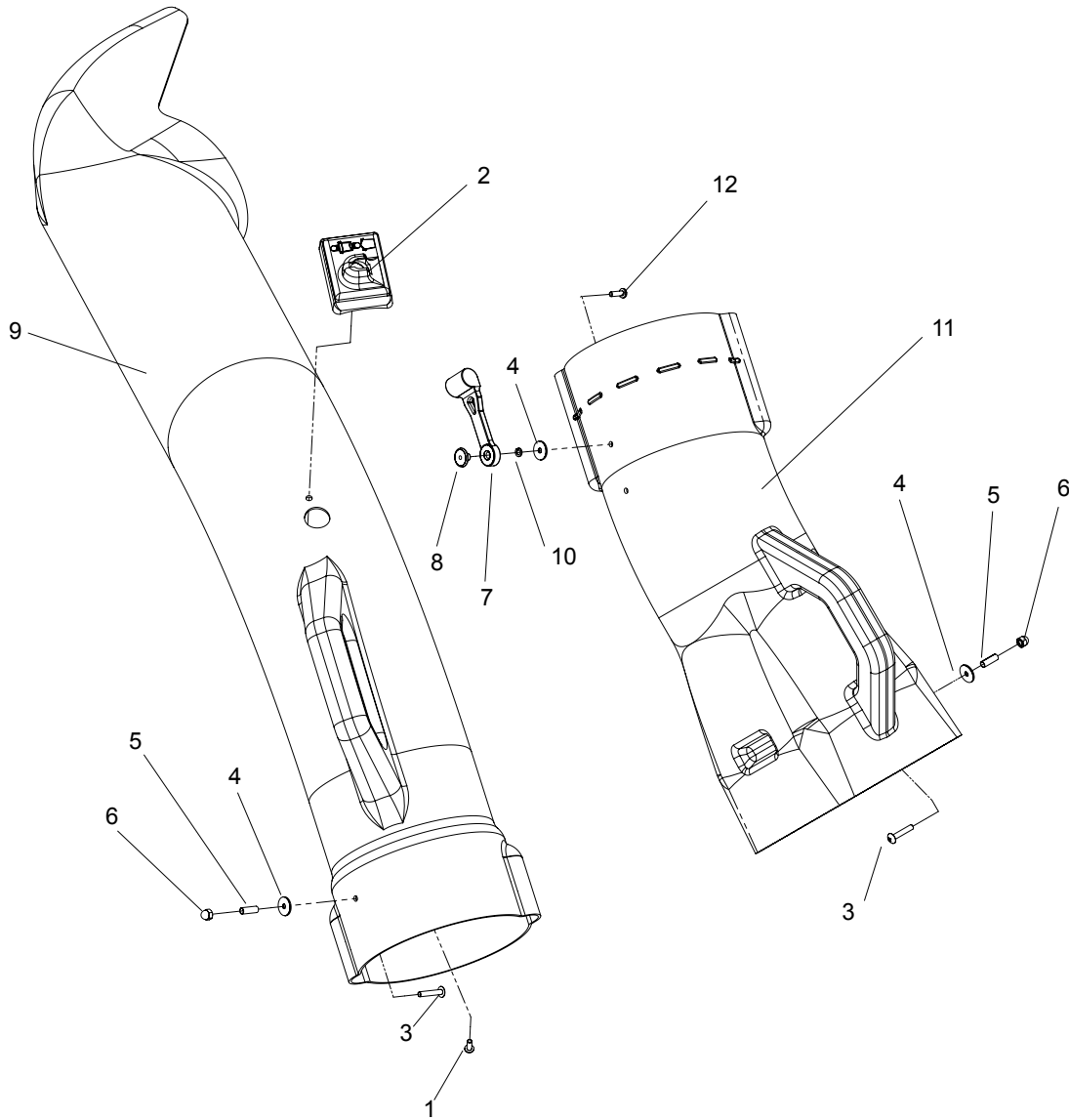

ITEM	PART NO.	QTY.	DESCRIPTION
1	539 108081	1	SCREW, SPEC 10- 14 x 1/2
2	539 108082	1	BAG DUMP INDICATOR
3	539 108083	2	SCREW, 10- 24 x 1 1/8
4	539 108084	3	WASHER, 3/16 x 3/4
5	539 108085	2	SPACER, SPLIT
6	539 108086	2	NUT, ACORN 10-24

ITEM	PART NO.	QTY.	DESCRIPTION
7	539 108088	1	LATCH, HOOD
8	539 108089	1	PLATED, WELD NUT
9	539 108141	1	CHUTE, UPPER
10	539 109552	2	WASH 3/16 LOCK
11	539 130294	1	CHUTE, MIDDLE
12	539 976952	1	SCREW 10-24 x .625 MACH

PARTS

BAG ASSEMBLY 2 bins

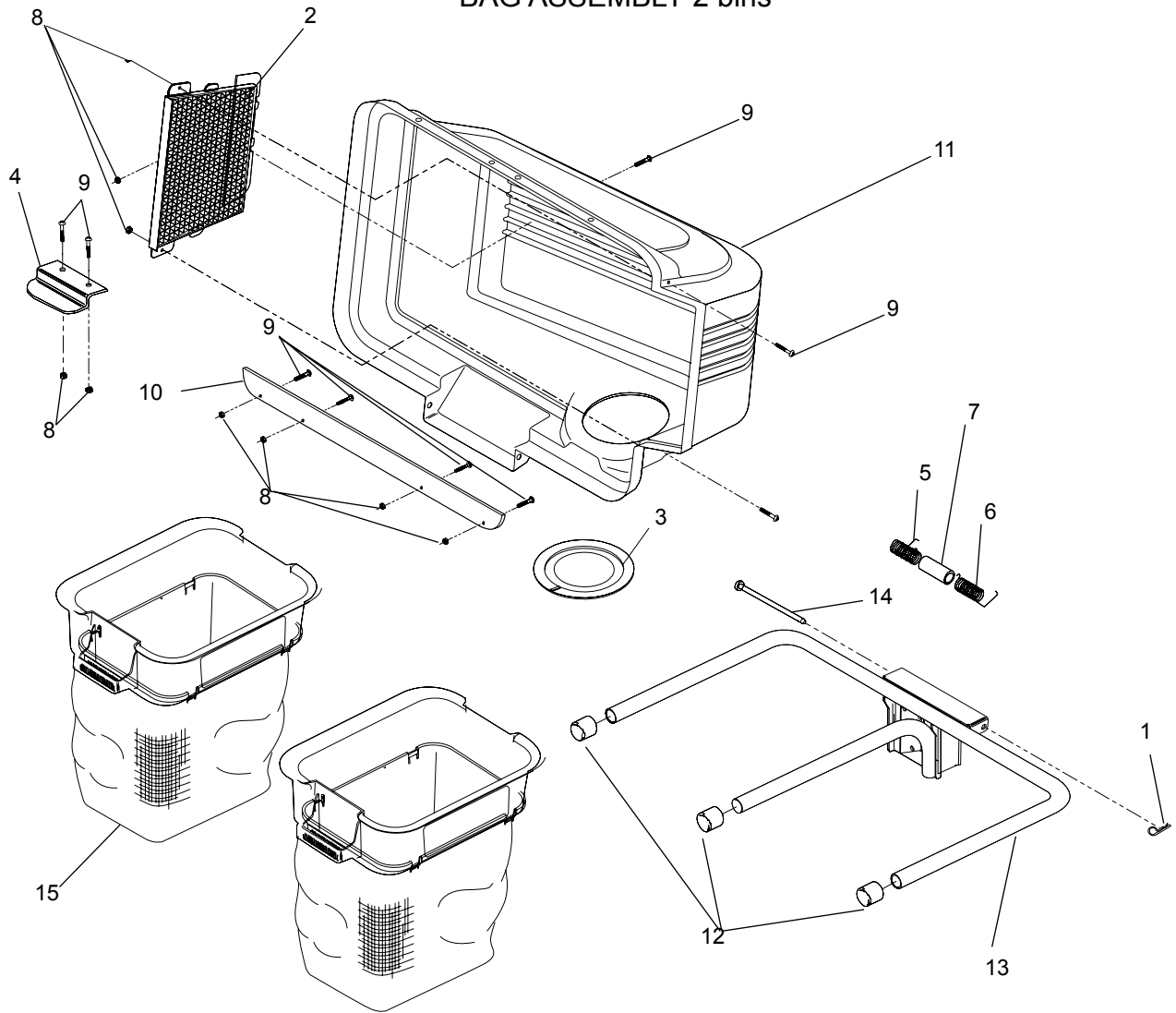

ITEM	PART NO.	QTY.	DESCRIPTION
1 ...	532 124670...	1...	RETAINER SPRING
2 ...	532 127533 ..	1...	SCREEN, COVER
3 ...	539 108100 ..	1...	GASKET, COVER
4 ...	532 130895 ..	1...	LATCH HANDLE, COVER
5 ...	532 132796...	1...	SPRING, COVER LT
6 ...	532 132983...	1...	SPRING, COVER RT
7 ...	532 133235...	1...	SPACER, COVER
8 ...	539 976977...	8...	NUT, 10-24 HEX W/WYLOC

ITEM	PART NO.	QTY.	DESCRIPTION
9 ...	539 991034...	8...	SCREW 10-24 x 5/8 WSH HD
10 ...	532 414173...	1...	STRIP, REINFORCEMENT
11 ...	532 160274...	1...	COVER, TOP
12 ...	532 174083...	3...	CAP, PLUG TUBING END
13 ...	532 414172...	1...	FRAME ASSEMBLY, 2-BIN
14 ...	532 192786...	1...	PIN, HINGE PIVOT
15 ...	532 400226...	2...	CONTAINER BAG, SOFT

PARTS

BAG ASSEMBLY 3 bins

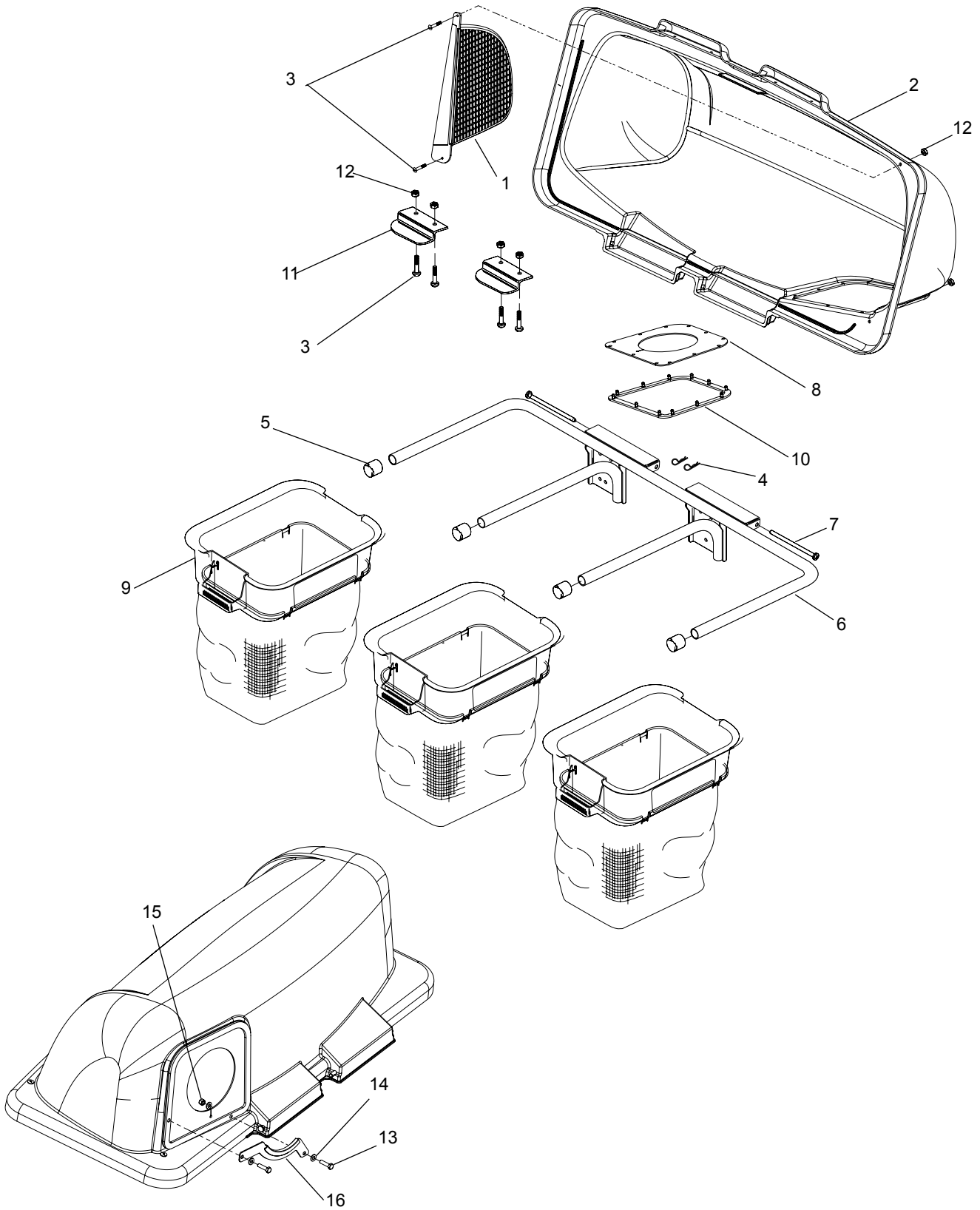

PARTS

ITEM	PART NO.	QTY.	DESCRIPTION	ITEM	PART NO.	QTY.	DESCRIPTION
1 ...	532 192709...	1...	SCREEN, COVER	12 ...	539 976977...	8...	NUT, #10-24, CROWNLOCK
2 ...	532 195373...	1...	COVER	13...	539 990627 ...	2...	HCS, ⁵ / ₁₆ -18 X 1¼, GR5
3 ...	539 976952...	6...	SCREW, #10-24 X ⁵ / ₈	14...	539 990188...	4...	WAS HER, ⁵ / ₁₆ , SAE
4 ...	539 108096...	2...	SPRING, RETAINER	15...	539 990717 ...	2...	NUT, ⁵ / ₁₆ -18, NYLOC
5 ...	539 108097...	4...	PLUG, TUBING END	16	539 110234...	1...	SUPPORT, CHUTE
6 ...	539 108098...	1...	BAGGER, FRAME	NOT SHOWN			
7 ...	532 192786...	2...	PIN, HINGE	...	539 108447...	1...	DECAL, CE
8 ...	532 192550...	1...	GASKET, COVER	...	539 108163...	1...	DECAL, CATCHER
9 ...	960 730019	...	3... CONTAINER			
10 ...	532 192603...	1...	SEAL, COVER				
11 ...	532 130895...	2...	HANDLE, BAGGER COVER				

PARTS

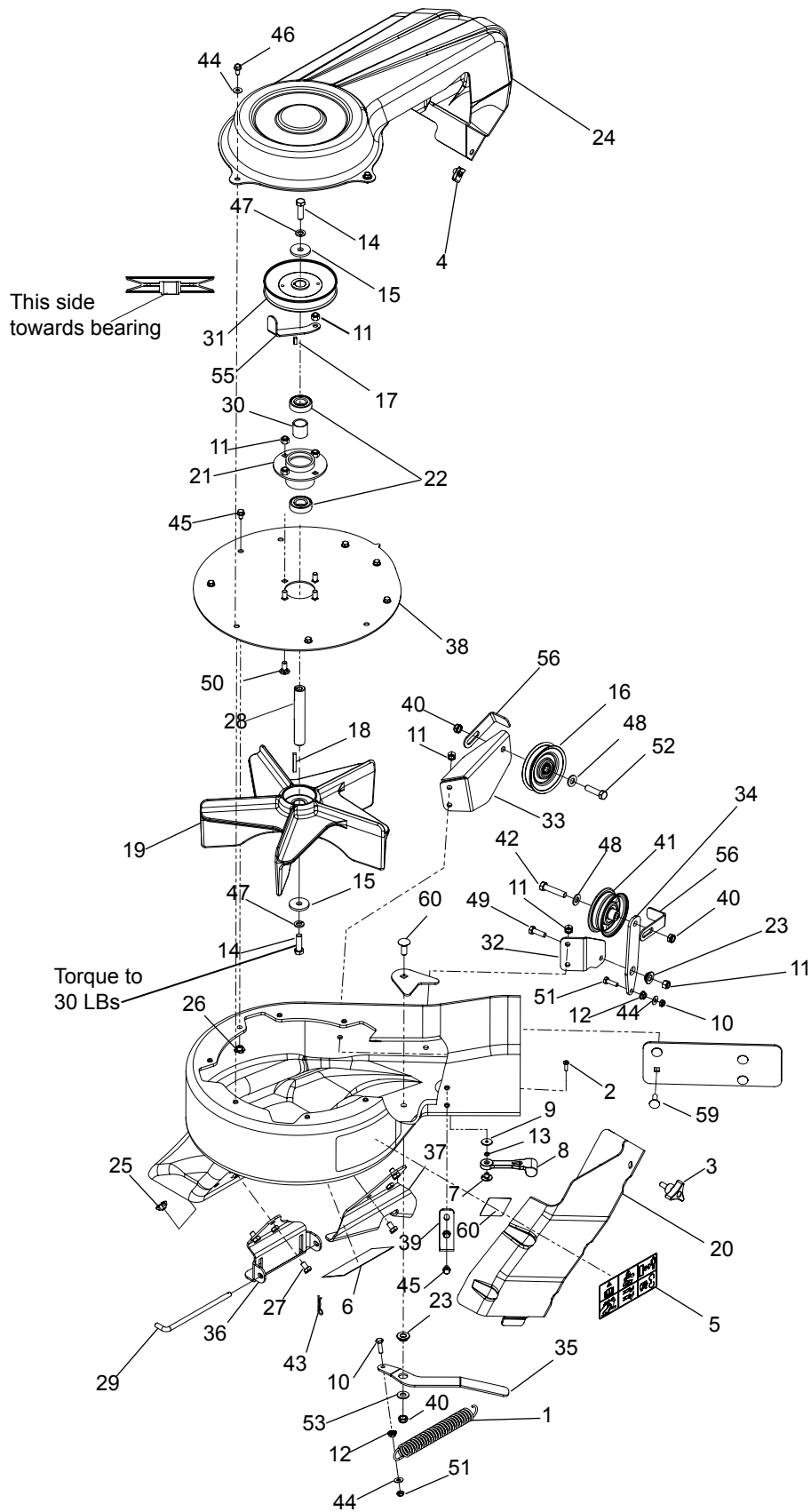

PARTS

ITEM	PART NO.	QTY.	DESCRIPTION	ITEM	PART NO.	QTY.	DESCRIPTION
1 ...	539 101977 ...	1 ...	TRACTION SPRING	30...	539 130323...	1 ...	SPACER
2 ...	539 976952...	1...	SCREW 10-24 x .625 RD	31...	539 130324...	1 ...	PULLEY
3 ...	539 104411 ...	1 ...	KNOB W/STUD	32 ...	539 130335...	1 ...	MOUNT, IDLER, UPPER
4 ...	539 104763...	1...	RETAINER ⁵ / ₁₆ "U" TYPE	33 ...	539 130336...	1 ...	MOUNT, IDLER, LOWER
5 ...	539 105785 ...	1 ...	EURO DECAL, WARNING	34 ...	539 130337...	1 ...	ARM, IDLER
6 ...	539 106741 ...	1...	EURO DECAL, SEVERING	35...	539 130338...	1 ...	ARM, TENSION
7 ...	539 108084 ...	1...	WASHER, ³ / ₁₆ x ³ / ₄ x 16 GA	36 ...	539 130339...	1 ...	BRKT, MT, FRONT
8 ...	539 108088...	1...	LATCH, HOOD	37 ...	539 130340...	1 ...	BRKT, MT, REAR
9 ...	539 108089 ...	1 ...	PLATED, WELD NUT	38 ...	539 130341...	1 ...	PLATE, OUTER
10 ...	539 108120...	2...	NUT ¹ / ₄ -20 HEX NYLOC ZD	39...	539 130346...	1 ...	KEEPER
11 ...	539 990717 ...	5...	NUT ⁵ / ₁₆ -18 HEX NYLOC ZD	40...	539 200282...	3 ...	NUT, ³ / ₈ -16 HEX JAM NYLOC
12 ...	539 108735...	2...	NUT ¹ / ₄ -20 HEX FLANGE	41 ...	539 919078...	1 ...	IDLER PULLEY
13...	539 109552 ...	2...	WASH ³ / ₁₆ LOCK ZD	42...	539 976949...	1 ...	HCS ³ / ₈ -16 x 1 ³ / ₄ GR 5 ZD
14 ...	539 110321 ...	2...	BOLT, HEX ³ / ₈ -24 x 1 ¹ / ₄ GR 8	43 ...	539 976988...	1 ...	HAIRPIN COTTER
15 ...	539 110323...	2...	WASHER, HARDENED	44 ...	539 990055.	13...	WASHER, ¹ / ₄ FLAT SAE ZD
16...	539 113683 ...	1 ...	V-IDLER	45 ...	539 990302...	8...	SCREW, ¹ / ₄ x ³ / ₈ THRD FRM
17...	539 115667 ...	1 ...	KEY, ³ / ₁₆ x ¹ / ₂	46 ...	539 108461...	3 ...	HCS ¹ / ₄ -20 x ¹ / ₂ GR 5 ZD
18...	539 125229 ...	1 ...	KEY-SQ. ³ / ₁₆ x 1 ¹ / ₂	47...	539 990118...	2 ...	WASHER, ³ / ₈ SPLT LOCK ZD
19...	539 130292...	1 ...	IMPELLER	48...	539 990122...	2 ...	WASHER, ³ / ₈ SAE FLT ZD
20 ...	539 130293...	1 ...	COVER, BELT	49...	539 990209...	1 ...	HCS ⁵ / ₁₆ -18 x 1 GR 5 ZD
21 ...	539 130295...	1...	HUB, BEARING	50...	539 990316...	4 ...	RHSNB ⁵ / ₁₆ -18 x ³ / ₄ GR5 ZD
22...	539 130296 ...	2...	BEARING	51 ...	539 990643...	2 ...	HCS ¹ / ₄ -20 x ⁷ / ₈ GR 5 ZD
23...	539 130301 ...	2...	BUSHING	52...	539 990655...	1 ...	HCS ³ / ₈ -16 x 1 ¹ / ₂ GR 5 ZD
24 ...	539 130309 ...	1 ...	COVER, OUTER PULLEY	53...	539 990692...	1 ...	WASHER, ⁵ / ₁₆ STD FLT ZD
25...	539 130313...	6...	NUT, ⁵ / ₁₆ -18 TEE	54 ...	539 130349...	1 ...	DECAL, BELT ROUTING
26 ...	539 130314 ..	11...	NUT, ¹ / ₄ -20 TEE	55 ...	539 131085...	1 ...	KEEPER, BELT, OUTER
27...	539 130315...	6...	HCS ⁵ / ₁₆ -18 x ¹ / ₂ GR 5 ZD	56 ...	539 131087...	2 ...	KEEPER, BELT, REAR
28 ...	539 130316 ...	1 ...	SHAFT, IMPELLER	57 ...	539 132122...	1 ...	PLATE, BACKING
29...	539 130317 ...	1 ...	PIN	58 ...	539 132124...	1 ...	PLATE, BACKING

PARTS

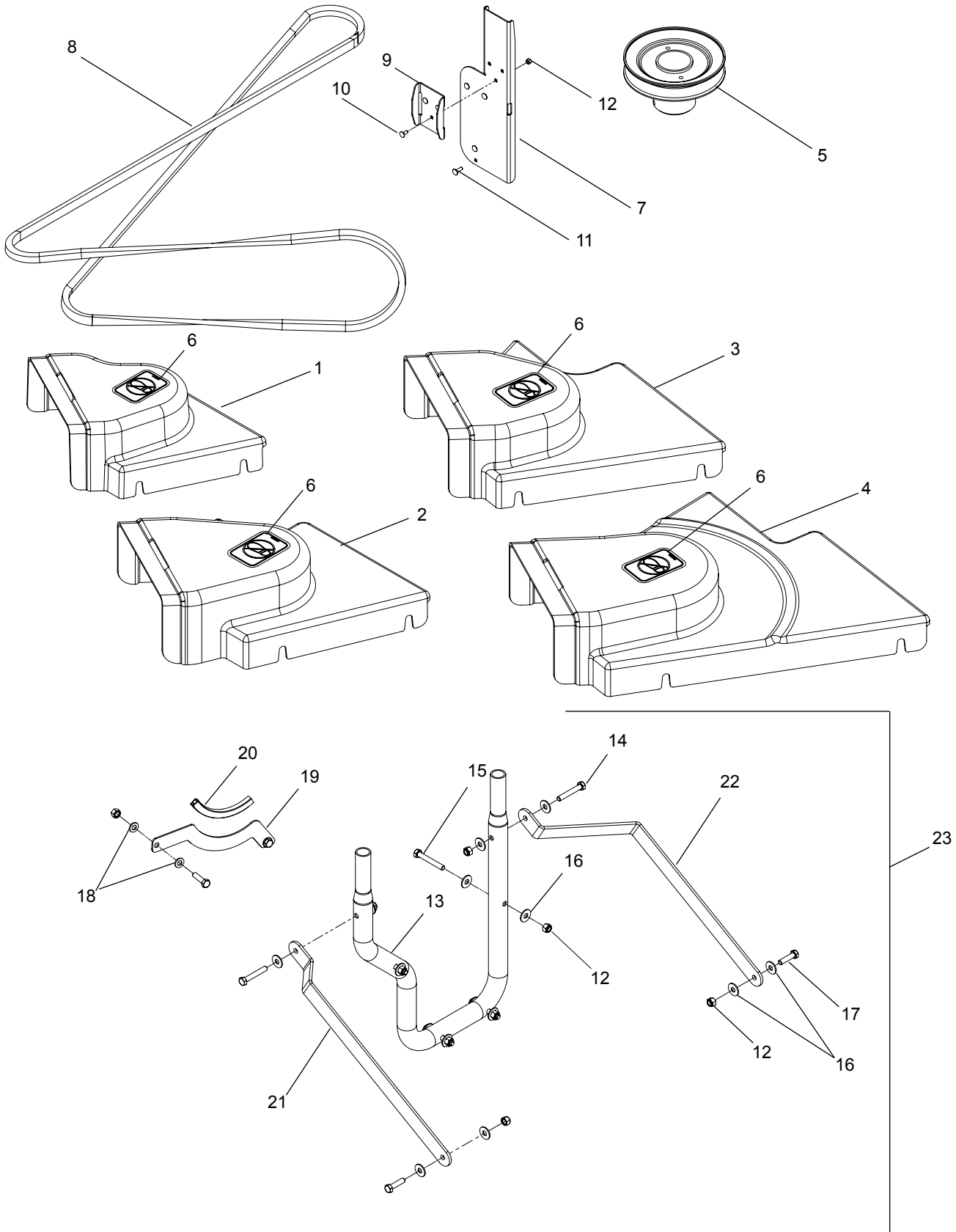

PARTS

ITEM	PART NO.	QTY.	DESCRIPTION
2	539 130306	1	SHIELD, BELT, 48"
3	539 130307	1	SHIELD, BELT, 52"
5	539 130319	1	PULLEY, 48"
	539 130320	1	PULLEY, 52"
6	539 105743	1	DECAL, EURO NO STEP
7	539 130342	1	PLATE, MOUNT
8	539 130347	1	BELT, 48/52"
9	539 130343	1	PLATE, BACKING
10	539 990316	3	RHSNB $\frac{5}{16}$ -18 x $\frac{3}{4}$

ITEM	PART NO.	QTY.	DESCRIPTION
11	539 990208	4	RRSNB $\frac{5}{16}$ -18 x 1
12	539 990717	13	NUT, $\frac{5}{16}$ -18 HEX NYLOC
13	539 131091	1	TUBE, MOUNT
14	539 976937	2	HCS $\frac{5}{16}$ -18 X 2 GR 5 ZD
15	539 976938	4	HCS $\frac{5}{16}$ -18 X 2 $\frac{1}{4}$ GR 5 ZD
16	539 990692	16	WASHER, $\frac{5}{16}$ STD FLT ZD
17	539 990627	4	HCS $\frac{5}{16}$ -18 X 1 $\frac{1}{4}$ GR 5 ZD
18	539 990188	4	WASH $\frac{5}{16}$ SAE FLAT ZD
19	539 110234	1	SUPPORT, HOSE
20	539 112294	1	FLEX TRIM, BLACK
21	539 131089	1	STRAP, RT
22	539 131090	1	STRAP, LT
23	539 130279	1	MOUNT KIT, COMPLETE

PARTS

WEIGHT KIT 42/48" 2 BIN

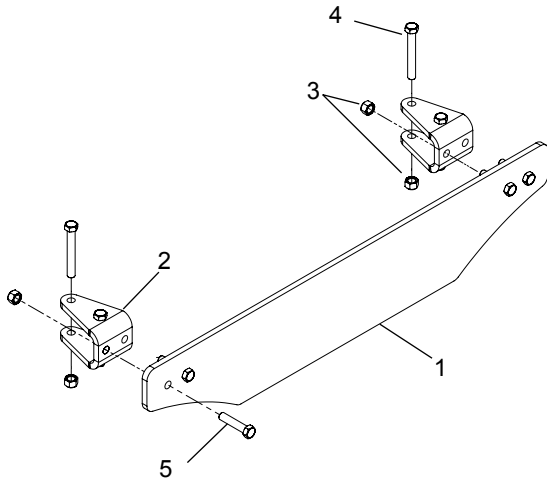

ITEM	PART NO.	QTY.	DESCRIPTION
1	539 113232	1	WEIGHT PLATE
2	539 113203	2	WEIGHT BRACKET
3	539 976979	8	NUT $\frac{3}{8}$ -16 HEX NYLOC ZD
4	539 102612	4	HCS $\frac{3}{8}$ -16 x $2\frac{3}{4}$ GR 5 ZD
5	539 976941	4	HCS $\frac{3}{8}$ -16 x $1\frac{1}{4}$ GR 5 ZD

WEIGHT KIT 42/48" 3 BIN

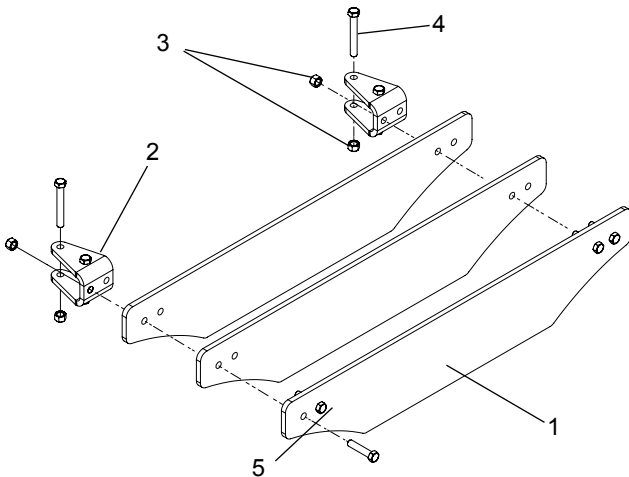

ITEM	PART NO.	QTY.	DESCRIPTION
1	539 113232	3	WEIGHT PLATE
2	539 113203	2	WEIGHT BRACKET
3	539 976979	8	NUT $\frac{3}{8}$ -16 HEX NYLOC ZD
4	539 102612	4	HCS $\frac{3}{8}$ -16 x $2\frac{3}{4}$ GR 5 ZD
5	539 976949	4	HCS $\frac{3}{8}$ -16 x $1\frac{3}{4}$ GR 5 ZD

WEIGHT KIT 52" 3 BIN

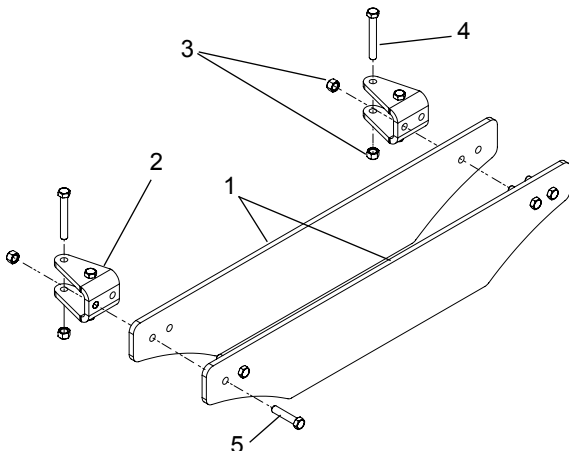

ITEM	PART NO.	QTY.	DESCRIPTION
1	539 113232	2	WEIGHT PLATE
2	539 113203	2	WEIGHT BRACKET
3	539 976979	8	NUT $\frac{3}{8}$ -16 HEX NYLOC ZD
4	539 102612	4	HCS $\frac{3}{8}$ -16 x $2\frac{3}{4}$ GR 5 ZD
5	539 976949	4	HCS $\frac{3}{8}$ -16 x $1\frac{3}{4}$ GR 5 ZD

