



SPARE PARTS LIST

ROBOTIC LAWN MOWERS

220 AC, 2010-01

H Accessories
Zubehöre
Accessoires
Accesorios
Tillbehör

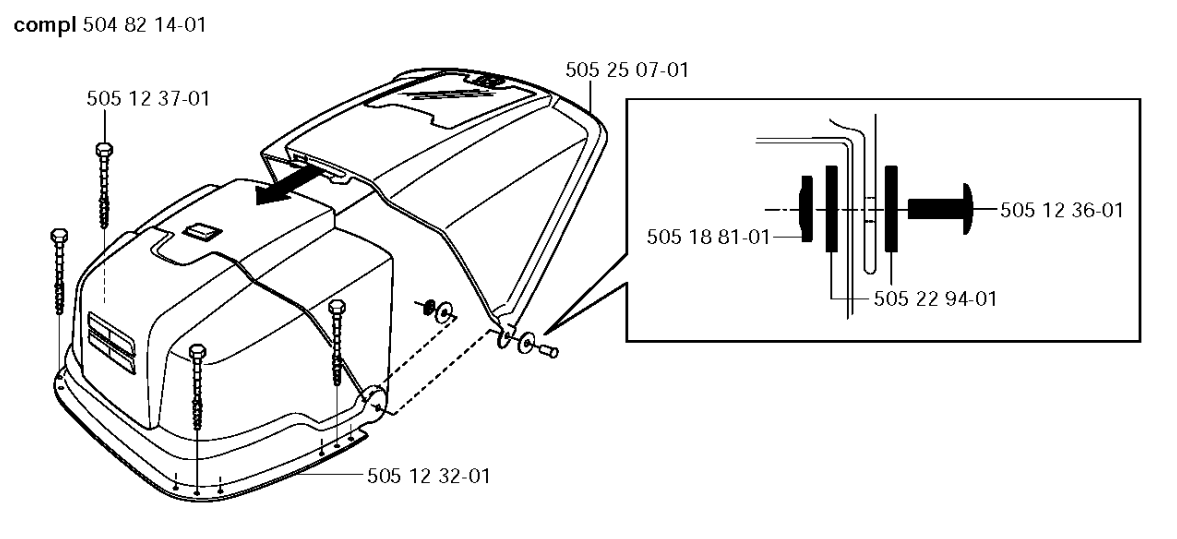
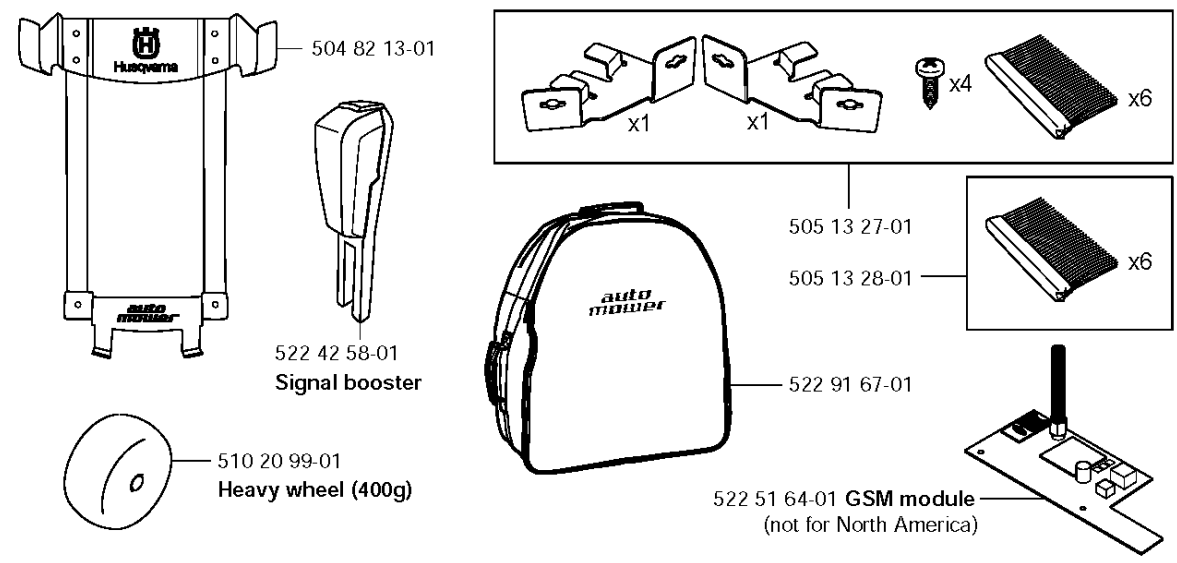
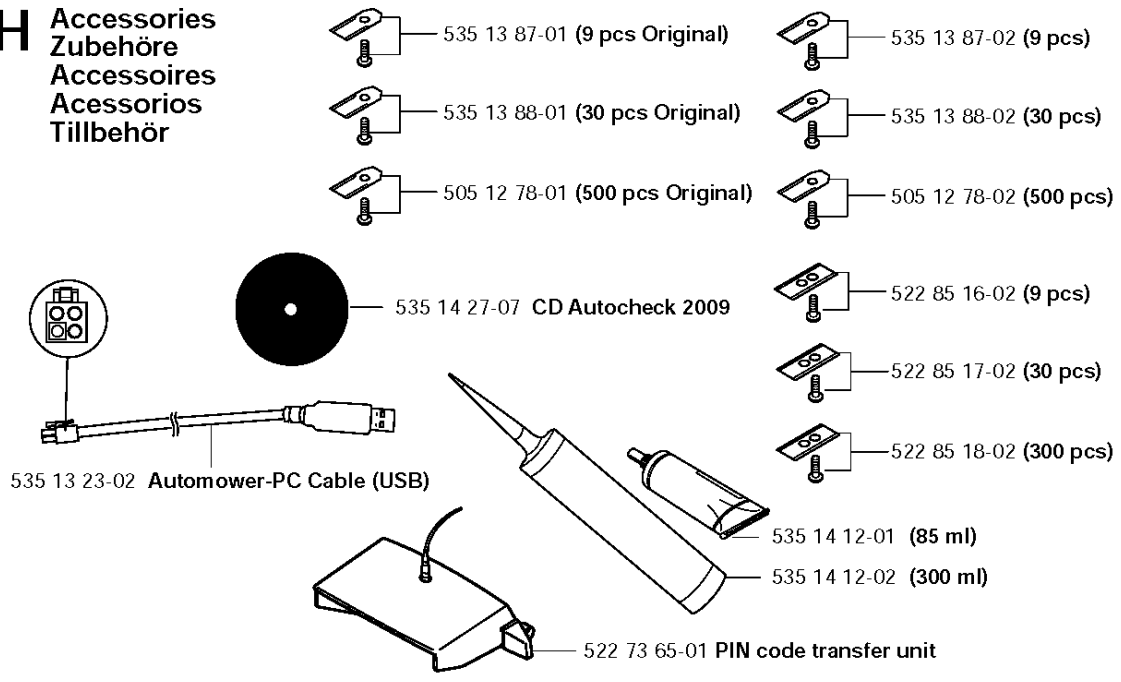

ACCESSORIES

220 AC, 2010-01

Part No	Description	Remark	QTY KIT
504 82 13-01	WALL HANGER		1
504 82 14-01	HOUSING		1
505 12 32-01	HOUSING		1
505 12 36-01	PIN		1
505 12 37-01	ANCHOR		1
505 12 78-01	BLADE		1
505 12 78-02	BLADE		1
505 13 27-01	BRUSH KIT		1
505 13 28-01	BRUSH		1
505 18 81-01	LOCK WASHER		1
505 22 94-01	WASHER		1
505 25 07-01	KIT		1
510 20 99-01	WHEEL		1
522 42 58-01	BOOSTER		1
522 51 64-01	GSM MODULE	Not for North America	1
522 73 65-01	ADAPTER		1
522 85 16-02	BLADE		1
522 85 17-02	BLADE		1
522 85 18-02	BLADE		1
522 91 67-01	BAG		1
535 13 23-02	WIRING		1
535 13 87-01	KIT		1
535 13 87-02	BLADE(9PCS)		1
535 13 88-01	KIT		1
535 13 88-02	BLADE 30PCS		1
535 14 12-01	SEALING	85 ml	1
535 14 12-02	SEALING	300 ml	1
535 14 27-07	AUTOMOWER CD		1

D

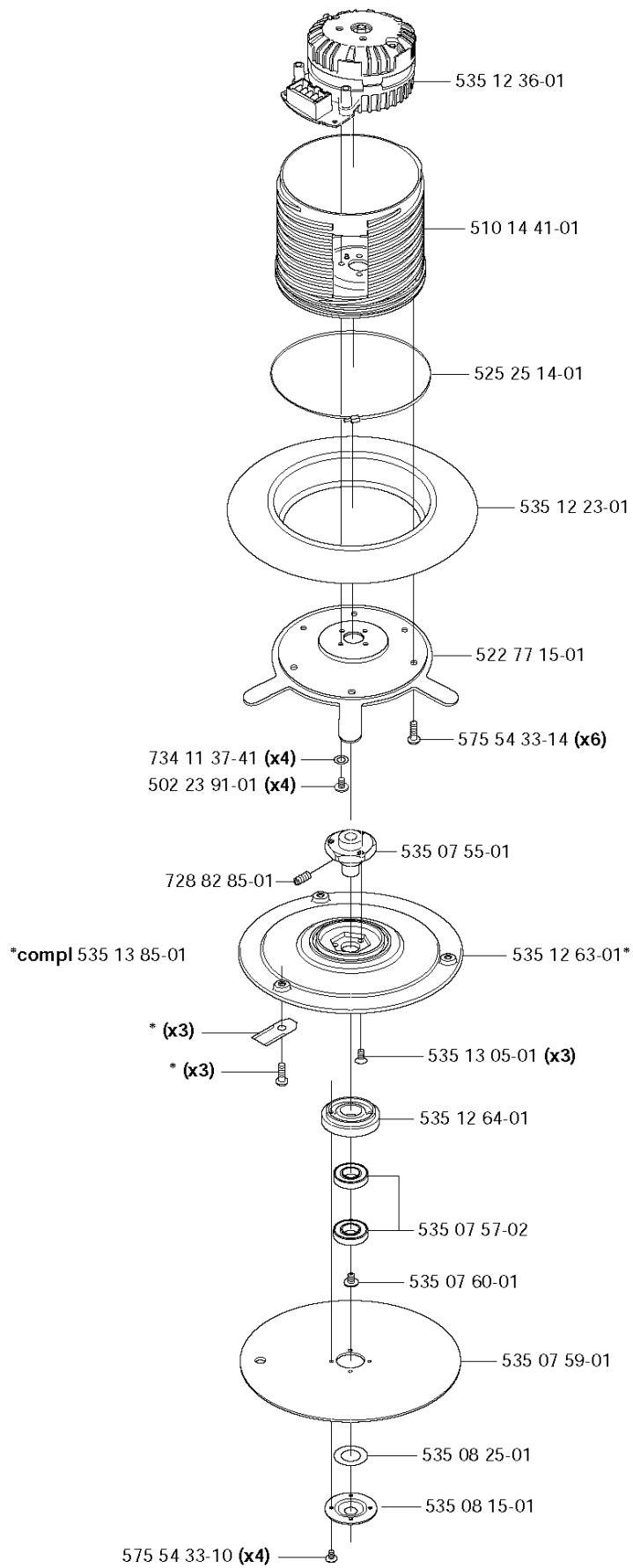

BLADE MOTOR & CUTTING EQUIPMENT

220 AC, 2010-01

Part No	Description	Remark	QTY KIT
502 23 91-01	SCREW		4
510 14 41-01	MOTOR BOWL		1
522 77 15-01	PLATE		1
525 25 14-01	TIE WRAP		1
535 07 55-01	HUB		1
535 07 57-02	BALL BEARING		1
535 07 59-01	SKID PLATE		1
535 07 60-01	SCREW		1
535 08 15-01	COVER WASHER		1
535 08 25-01	GASKET		1
535 12 23-01	RUBBER GAITERS		1
535 12 36-01	CUTTING ENGINE		1
535 12 63-01	KNIFE DISK		1
535 12 64-01	BEARING BOX		1
535 13 05-01	SCREW		3
535 13 85-01	KIT		1
575 54 33-10	SCREW		4
575 54 33-14	SCREW		6
728 82 85-01	SCREW IHSETM		1
734 11 37-41	WASHER		4

E compl 574 90 20-01

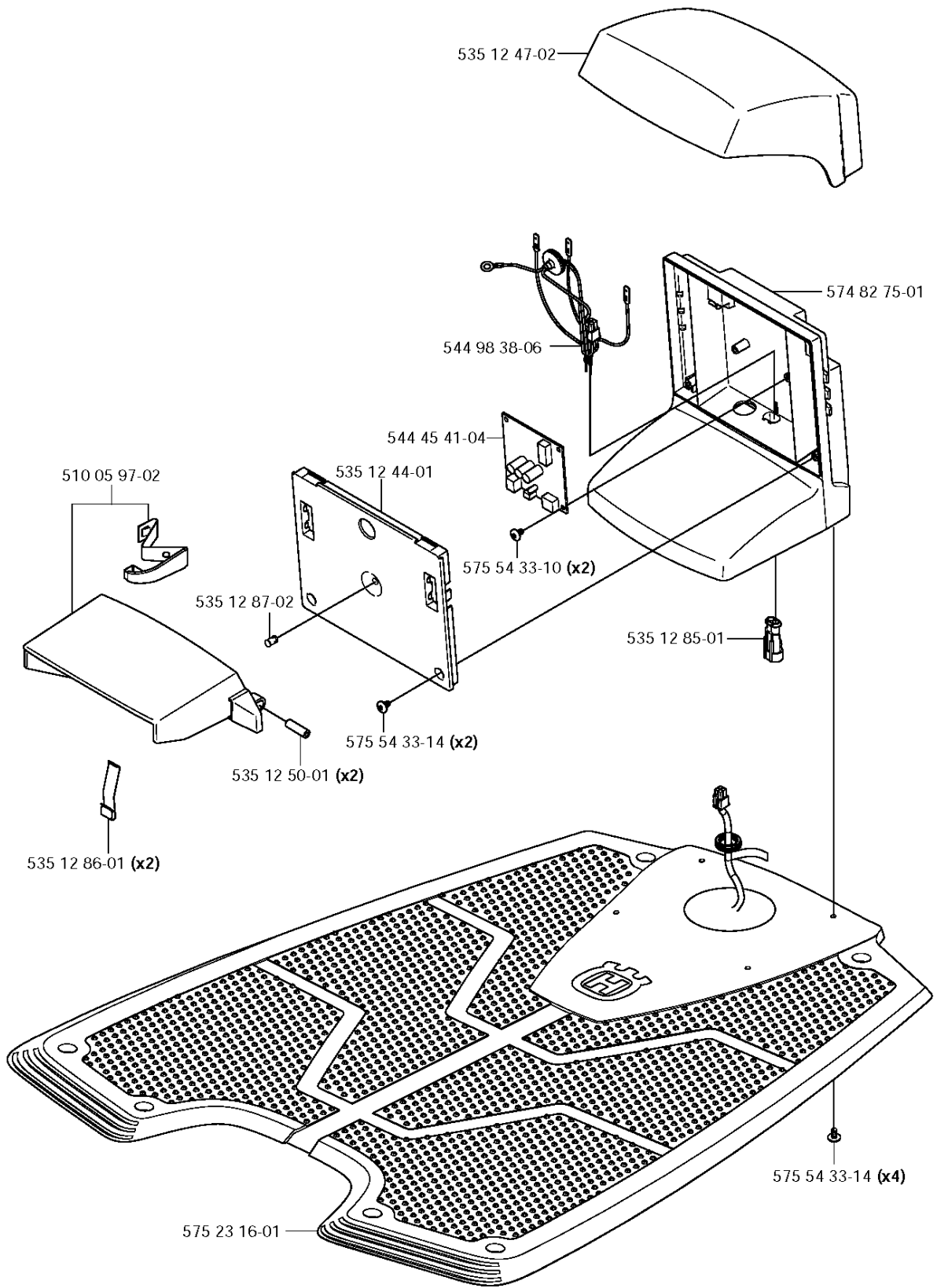

CHARGING STATION

220 AC, 2010-01

Part No	Description	Remark	QTY KIT
510 05 97-02	KIT		1
535 12 44-01	HUB CAP		1
535 12 47-02	COVER		1
535 12 50-01	PIN		2
535 12 85-01	CONTACT HOUSING		1
535 12 86-01	SPRING PLATE		2
535 12 87-02	DIODE LENS		1
544 45 41-04	CIRCUIT BOARD ASSY		1
544 98 38-06	WIRING ASSY		1
574 82 75-01	BODY		1
575 23 16-01	CHARGING PLATE		1
575 54 33-10	SCREW		2
575 54 33-14	SCREW		2
575 54 33-14	SCREW		4

- F** compl 575 24 13-01 (EU)
- compl 575 24 13-02 (UK)
- compl 575 24 13-03 (CH)
- compl 575 24 13-04 (US/CA)
- compl 575 24 13-05 (AU/NZ)
- compl 575 24 13-06 (MX)

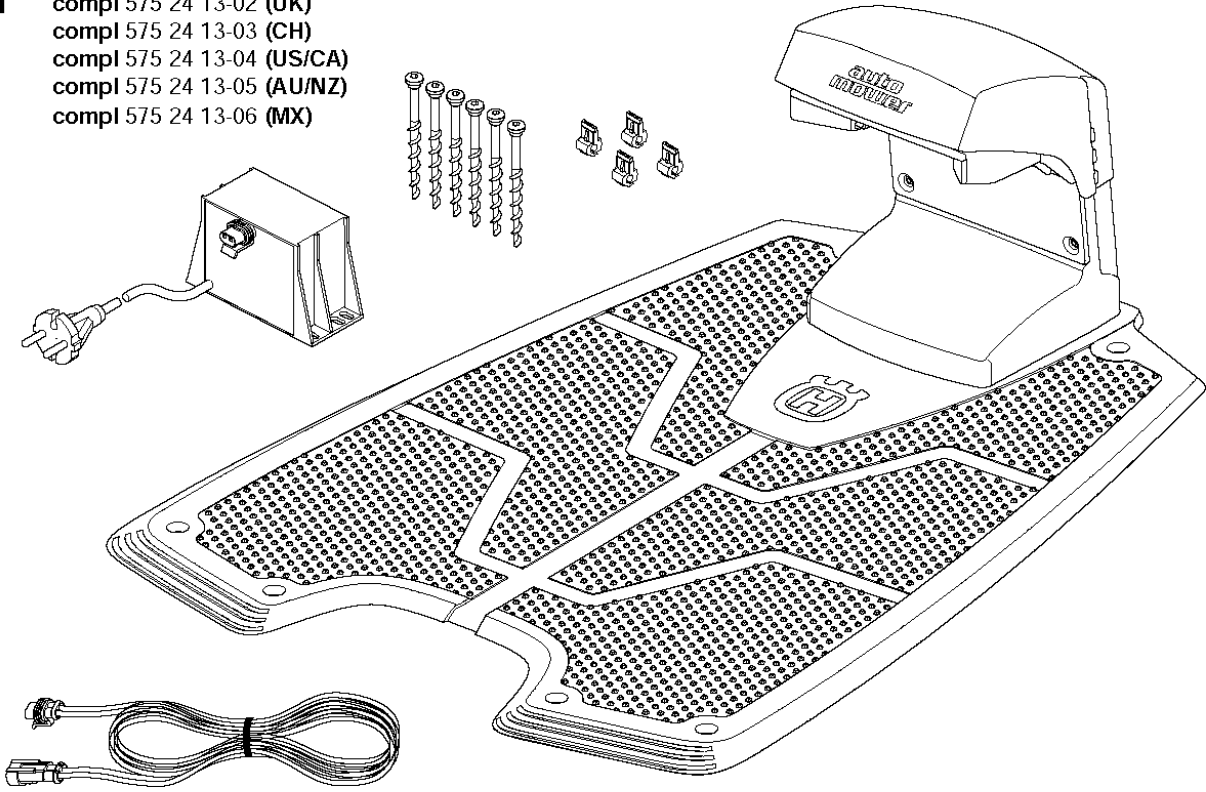

CHARGING STATION

220 AC, 2010-01

Part No	Description	Remark	QTY KIT
575 24 13-01	CHARGING STATION		1
575 24 13-02	CHARGING STATION		1
575 24 13-03	CHARGING STATION		1
575 24 13-04	CHARGING STATION		1
575 24 13-05	CHARGING STATION		1
575 24 13-06	CHARGING STATION		1

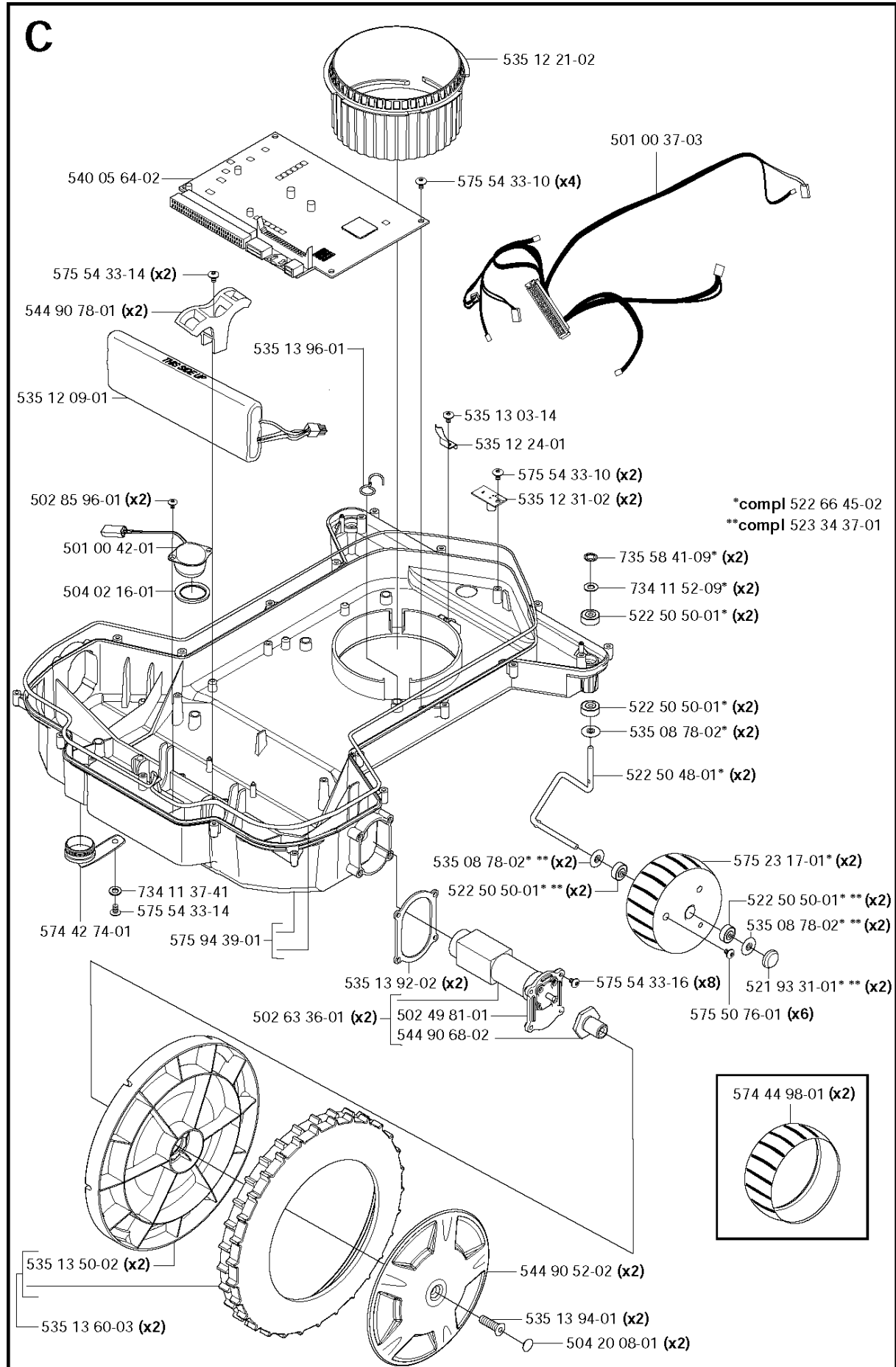

CHASSIS LOWER

220 AC, 2010-01

Part No	Description	Remark	QTY KIT
501 00 37-03	MAIN WIRING		1
501 00 42-01	LOUD SPEAKER		1
502 49 81-01	GABLE		1
502 63 36-01	DRIVE MOTOR		2
502 85 96-01	SCREW		2
504 02 16-01	SEALING		1
504 20 08-01	COVER WASHER		2
521 93 31-01	COVER WASHER		2
522 50 48-01	SPINDLE		2
522 50 50-01	BALL BEARING		2
522 50 50-01	BALL BEARING		2
522 50 50-01	BALL BEARING		2
522 66 45-02	KIT		1
523 34 37-01	BEARING KIT		1
535 08 78-02	WASHER		2
535 08 78-02	WASHER		2
535 12 09-01	BATTERY		1
535 12 21-02	NUT		1
535 12 24-01	LOCKING SPRING		1
535 12 31-02	SENSOR CARD		2
535 13 03-14	SCREW ITXPANT		1
535 13 50-02	WHEEL		2
535 13 60-03	GEAR WHEEL		2
535 13 92-02	GASKET		2
535 13 94-01	SCREW IHCSFM		2
535 13 96-01	CABLE HOLDER		1
540 05 64-02	PRINTED CIRCUIT ASSY		1
544 90 52-02	HUB CAP		2
544 90 68-02	HUB		1
544 90 78-01	BRACKET		2
574 42 74-01	PLUG		1
574 44 98-01	WHEEL		2
575 23 17-01	WHEEL ASSY		2
575 50 76-01	SCREW ITXPANT		6
575 54 33-10	SCREW		4
575 54 33-10	SCREW		2
575 54 33-14	SCREW		1
575 54 33-14	SCREW		2
575 54 33-16	SCREW		8
575 94 39-01	CHASSIS		1
734 11 37-41	WASHER		1
734 11 52-09	WASHER		2
735 58 41-09	WASHER		2

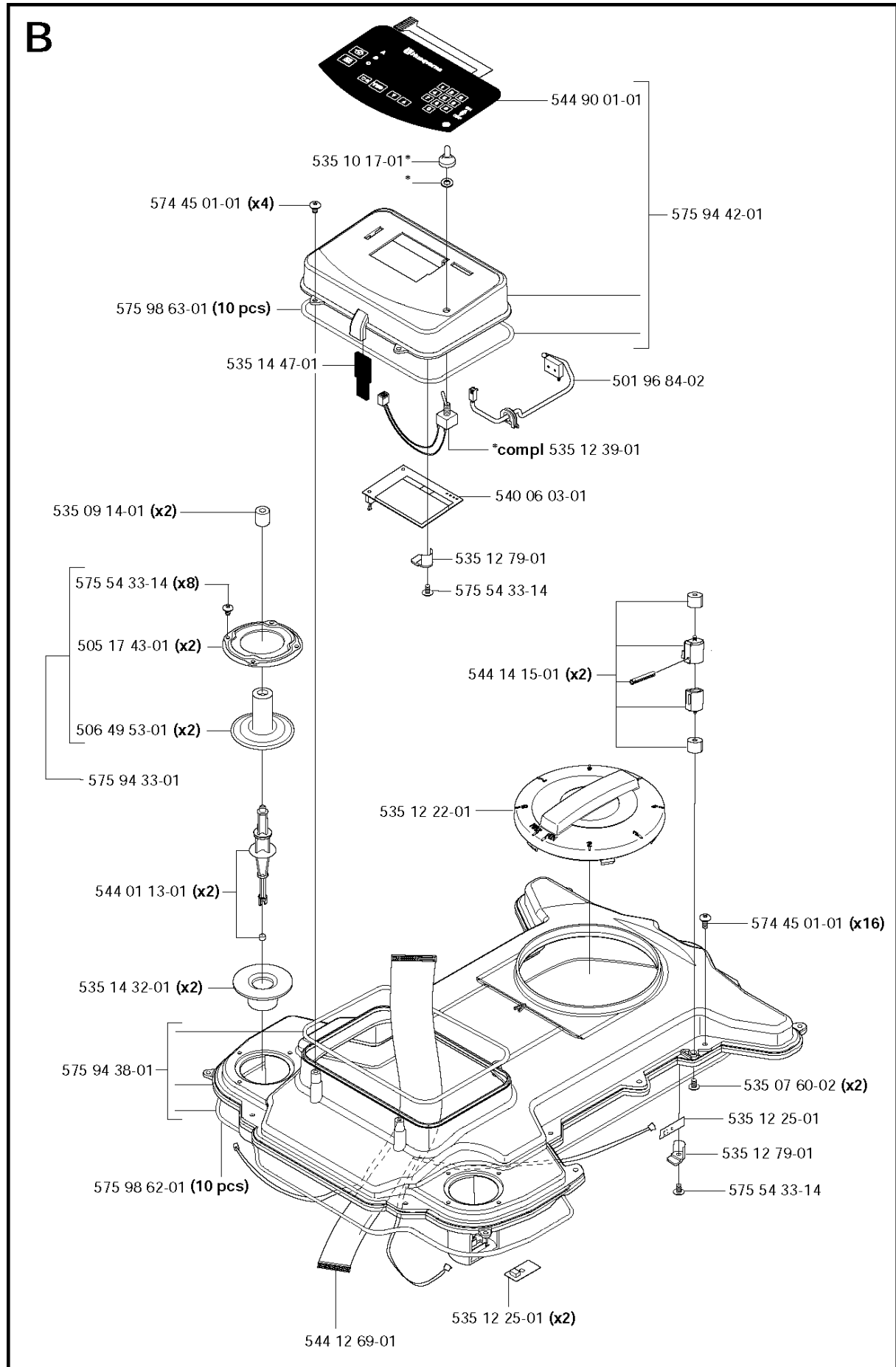

CHASSIS UPPER

220 AC, 2010-01

Ref	Part No	Description	Remark	QTY KIT
544 90 01-01	544 90 01-01	KEYBOARD		1
575 94 42-01	575 94 42-01	DISPLAY COVER		1
501 96 84-02	501 96 84-02	SWITCH		1
535 12 39-01	535 12 39-01	MAIN SWITCH		1
535 12 79-01	535 12 79-01	BRACKET		1
575 54 33-14	575 54 33-14	SCREW		1
535 14 47-01	535 14 47-01	FILTER		1
575 98 63-01	575 98 63-02	SEALING STRIP		1
574 45 01-01	574 45 01-01	SCREW ITXPANT		4
535 10 17-01	535 10 17-01	HUB CAP		1
535 09 14-01	535 09 14-01	RUBBER DAMPER		2
575 54 33-14	575 54 33-14	SCREW		8
505 17 43-01	505 17 43-01	RING FASTENER		2
506 49 53-01	506 49 53-01	RUBBER GAITERS		2
575 94 33-01	575 94 33-01	KIT		1
544 14 15-01	544 14 15-01	SENSOR		2
535 12 22-01	535 12 22-01	STEERING WHEEL		1
544 01 13-01	544 01 13-01	COLUMN		2
535 14 32-01	535 14 32-01	DEFLECTION LIMITER		2
574 45 01-01	574 45 01-01	SCREW ITXPANT		16
575 94 38-01	575 94 38-01	CHASSIS		1
535 07 60-02	535 07 60-02	SCREW		2
575 54 33-14	575 54 33-14	SCREW		1
535 12 79-01	535 12 79-01	BRACKET		1
535 12 25-01	535 12 25-01	SENSOR CARD		1
575 98 62-01	575 98 62-02	SEALING STRIP		1
544 12 69-01	544 12 69-01	WIRING		1
535 12 25-01	535 12 25-01	SENSOR CARD		2

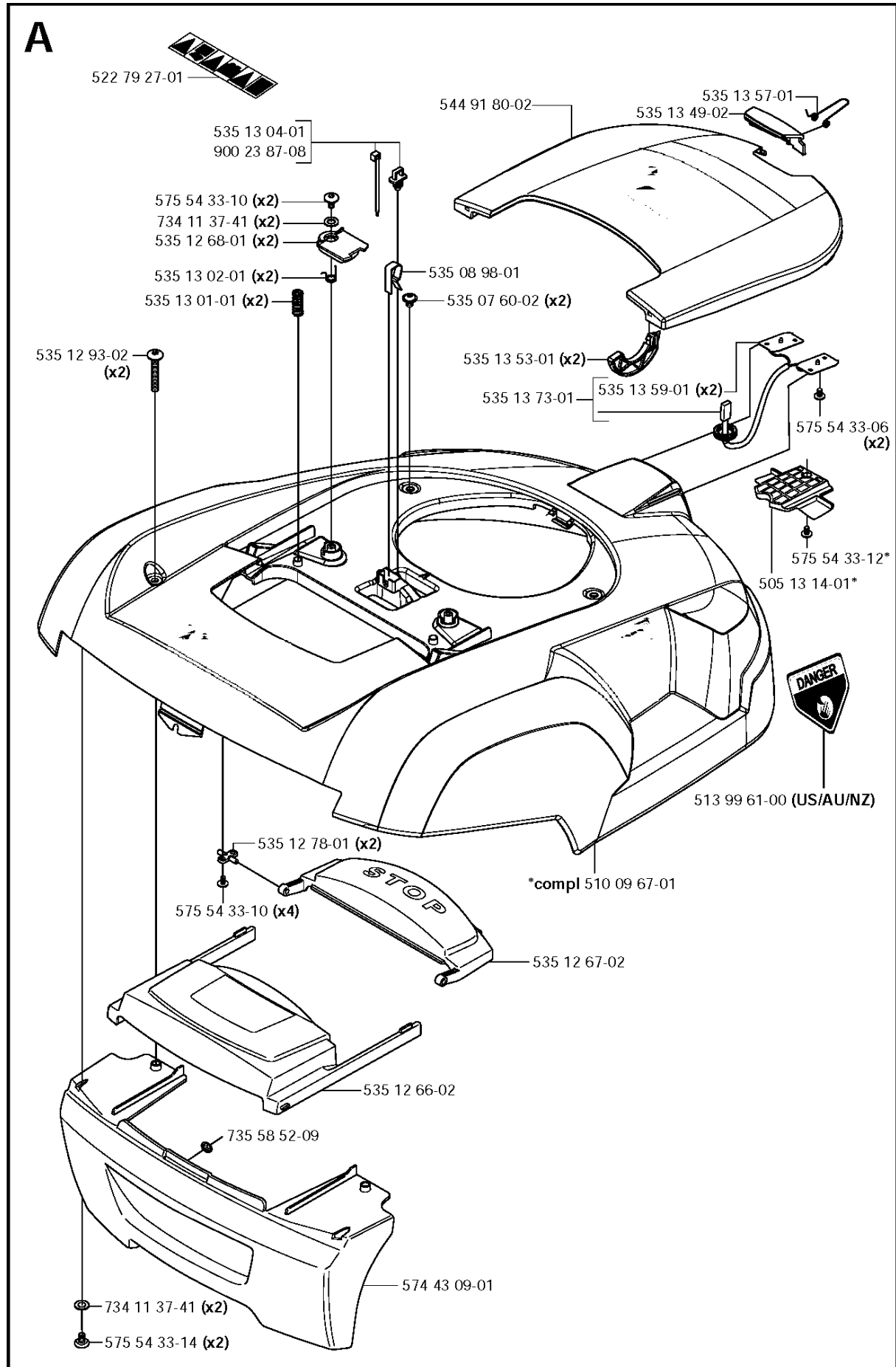

COVER

220 AC, 2010-01

Part No	Description	Remark	QTY KIT
505 13 14-01	SPACER		1
513 99 61-00	DECAL		1
522 79 27-01	LABEL WARNING		1
535 07 60-02	SCREW		2
535 08 98-01	CLIPS		1
535 12 66-02	COVER		1
535 12 67-02	SWITCH		1
535 12 68-01	LOCK CLAMP		2
535 12 78-01	SHAFT		2
535 12 93-02	SCREW IHPANM		2
535 13 01-01	SPRING		2
535 13 02-01	TORSION SPRING		2
535 13 04-01	ANCHOR		1
535 13 49-02	LOCK		1
535 13 53-01	PIVOT		2
535 13 57-01	TORSION SPRING		1
535 13 59-01	CHARGING PLATE		2
535 13 73-01	WIRING		1
544 91 80-02	COVER		1
574 43 09-01	BUMPER		1
575 54 33-06	SCREW		2
575 54 33-10	SCREW		2
575 54 33-10	SCREW		4
575 54 33-12	SCREW		1
575 54 33-14	SCREW		2
734 11 37-41	WASHER		2
734 11 37-41	WASHER		2
735 58 52-09	WASHER		1
900 23 87-08	TIE WRAP		1

G

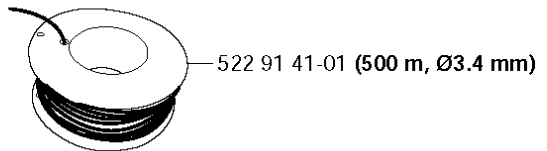
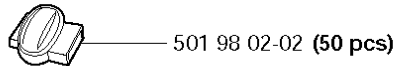
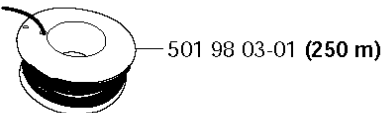
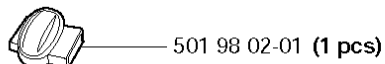
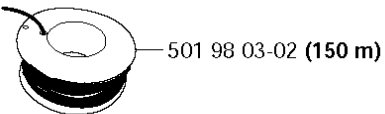
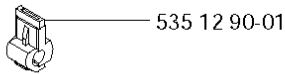
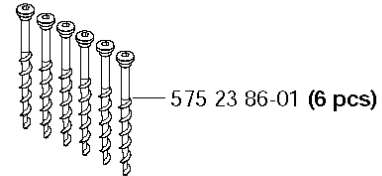
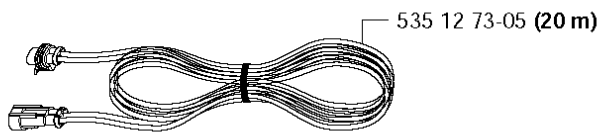
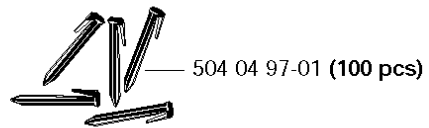
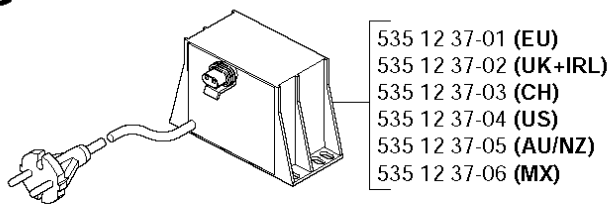

544 17 75-01



INSTALLATION ACCESSORIES

220 AC, 2010-01

Part No	Description	Remark	QTY KIT
501 98 02-01	COUPLER		1
501 98 02-02	COUPLER		1
501 98 03-01	WIRE		1
501 98 03-02	WIRE		1
504 04 97-01	STAPLE		1
522 91 41-01	WIRE		1
535 12 37-01	TRANSFORMER		1
535 12 37-02	TRANSFORMER		1
535 12 37-03	TRANSFORMER		1
535 12 37-04	TRANSFORMER		1
535 12 37-05	TRANSFORMER		1
535 12 37-06	TRANSFORMER		1
535 12 73-05	CABLE		1
535 12 90-01	COUPLER		1
535 13 16-01	LABEL		1
544 17 75-01	MEASURING TAPE		1
575 23 86-01	SCREW KIT		1