

ILLUSTRATED PARTS LIST

MFG. ID NO. 96041002204

CUSTOMER CATALOG NO. YTH150TWIN

PRODUCT NO. 960 41 00-22

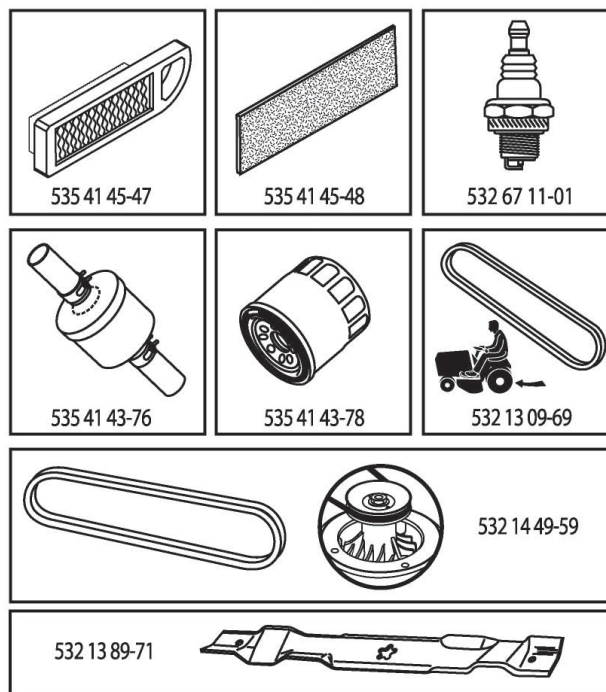

47

408762

TRACTOR - - MODEL NO. YTH150TWIN (96041002204), PRODUCT NO. 960 41 00-22
DECALS **27**

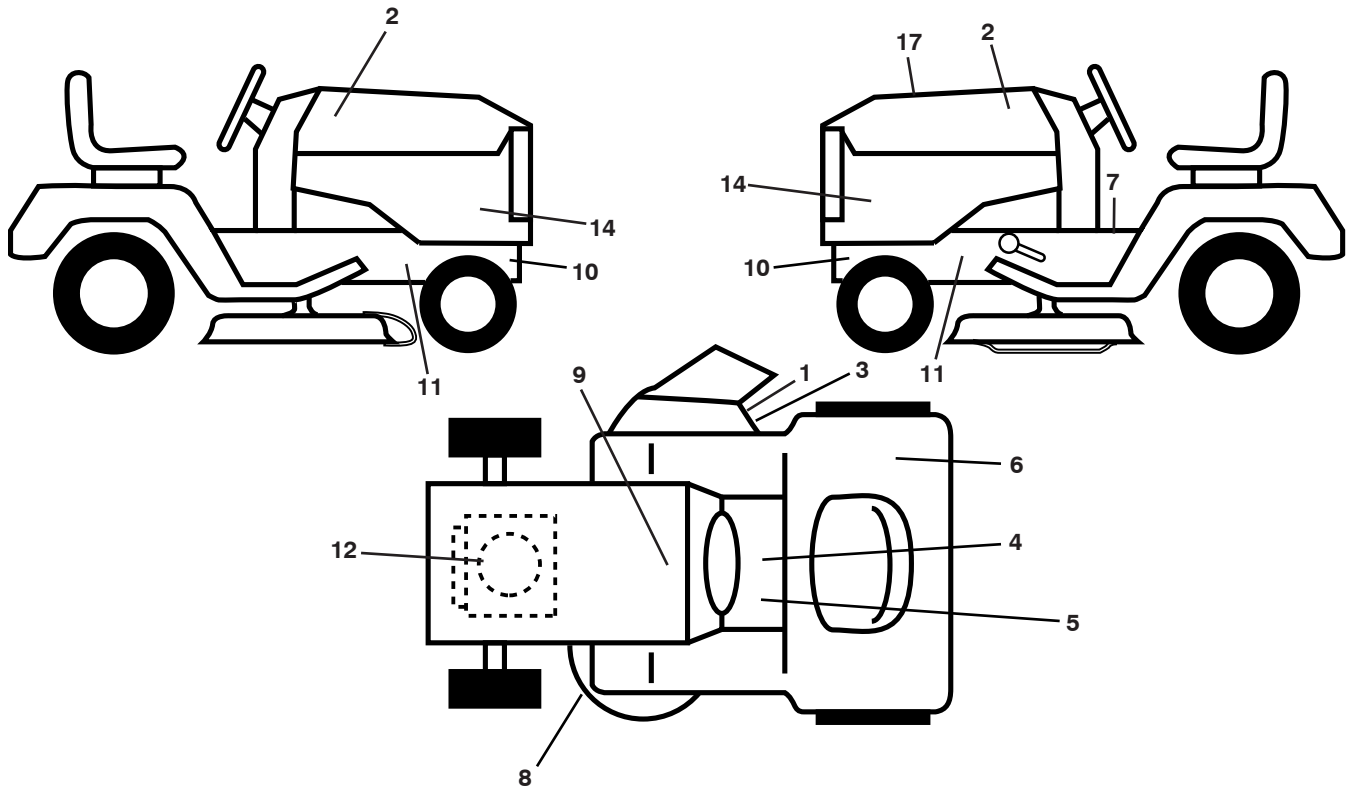

KEY NO.	PART NO.	DESCRIPTION
1	532 18 21-66	Decal, Cutfinger Warning
2	532 42 91-96	Decal, Hood
3	532 19 63-57	Decal, Warning Symbol
4	532 14 08-37	Decal, Brake Parking
5	532 40 03-89	Decal, Warning Symbol CE
6	532 18 04-32	Decal, Fender DB/CE
7	532 15 97-37	Decal, Brake/Clutch Symbol
8	532 16 03-96	Decal, Mower Sch.
9	532 14 50-05	Decal, Battery Dnge/Poi
10	532 15 97-36	Decal, Hot Muffler

KEY NO.	PART NO.	DESCRIPTION
11	532 40 11-46	Decal, Warning Service/Fire
12	532 19 68 41	Decal, Warning Engine
14	532 40 85-98	Decal, Panel Side
17	532 40 87-62	Decal, Replacement
--	532 16 69-60	Decal, Bypass
--	532 16 25-98	Decal, Load Limit
--	532 40 17-71	Pad, Footrest, LH
--	532 40 17-70	Pad, Footrest, RH
--	532 41 62-95	Manual Oper. Euro

WHEELS AND TIRES

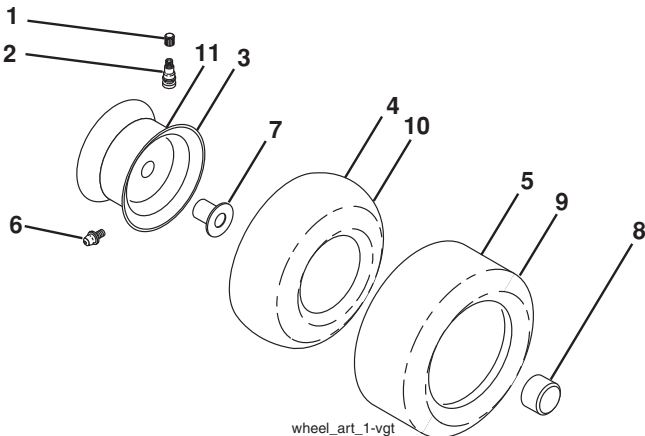

KEY NO.	PART NO.	DESCRIPTION
1	532 05 91-92	Cap, Valve, Tire
2	532 06 51-39	Stem, Valve
3	532 13 83-36	Rim Assembly, Front
4	532 05 99-04	Tube, Front (Service Item Only)
5	532 10 62-22	Tire, Front
6	532 12 49-57	Fitting, Grease (Front Wheel Only)
7	532 12 49-59	Bearing, Flange (Front Wheel Only)
8	532 17 50-39	Cap, Axle
9	532 12 20-82	Tire, Rear
10	532 12 49-26	Tube, Rear (Service Item Only)
11	532 13 83-37	Rim Assembly, Rear
--	532 14 43-34	Sealant, Tire (10 oz. Tube)

NOTE: All component dimensions given in U.S. inches
1 inch = 25.4 mm

TRACTOR - - MODEL NO. YTH150TWIN (96041002204), PRODUCT NO. 960 41 00-22 SCHEMATIC **38**

SCH12

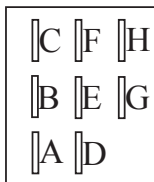
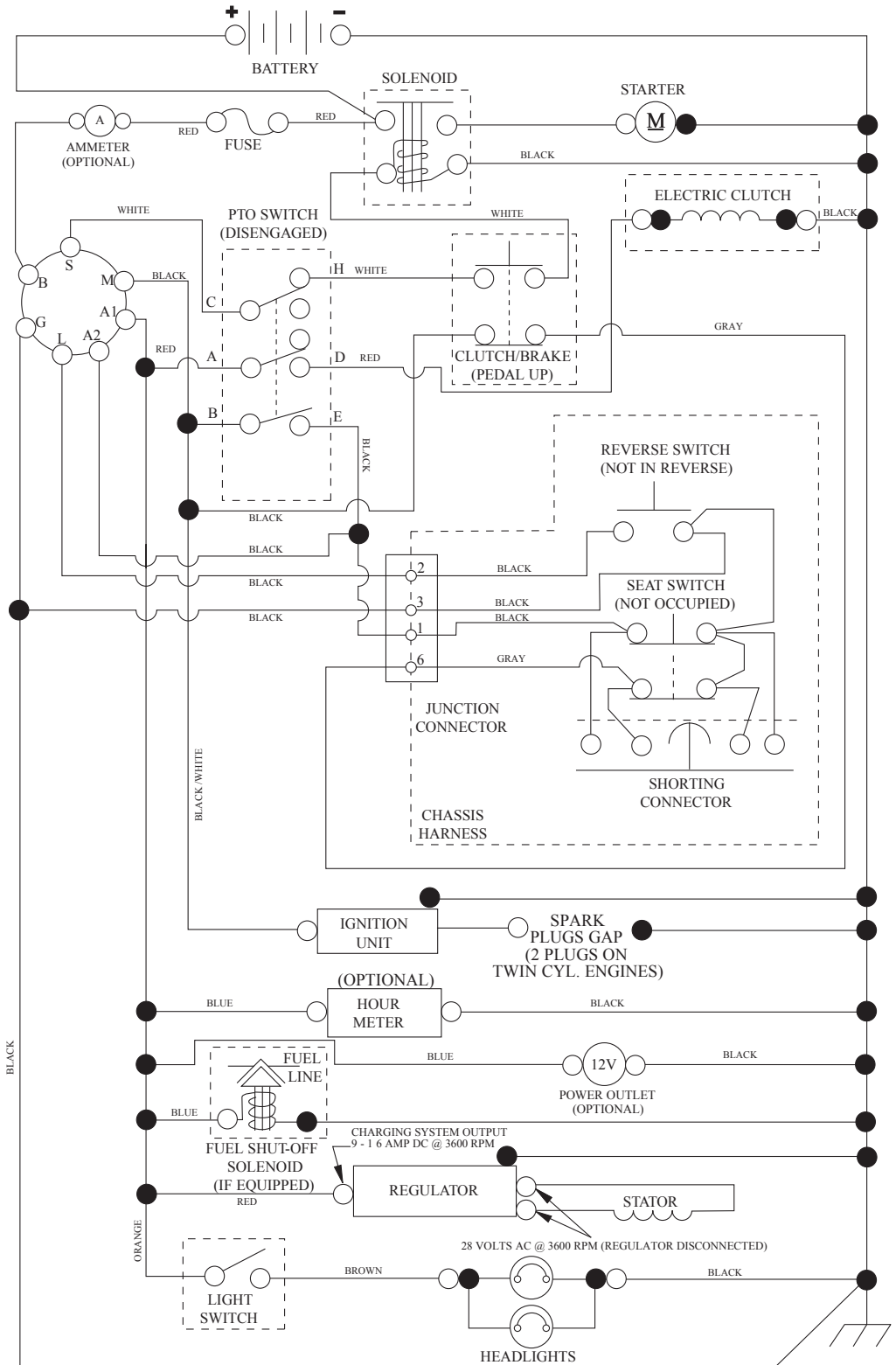

PTO SWITCH
(MATING SIDE)

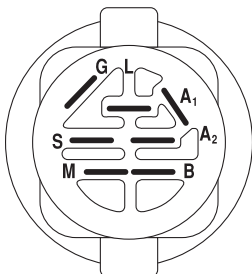

IGNITION SWITCH

POSITION	CIRCUIT	"MAKE"
OFF	M+G+A1	
RUN/OVERRIDE	B+A1	
RUN	B+A1	L+A2
START	B+S+A1	

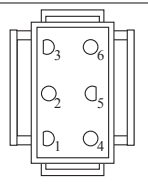

CHASSIS HARNESS
CONNECTOR
(MATING SIDE)

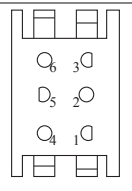

DASH HARNESS
CONNECTOR

WIRING INSULATED CLIPS
NOTE: IF WIRING INSULATED
CLIPS WERE REMOVED FOR
SERVICING OF UNIT, THEY
SHOULD BE RE-INSTALLED TO
PROPERLY SECURE YOUR
WIRING.

●
NON-REMOVABLE
CONNECTIONS

○
REMOVABLE
CONNECTIONS

TRACTOR - - MODEL NO. YTH150TWIN (96041002204), PRODUCT NO. 960 41 00-22
ELECTRICAL 32

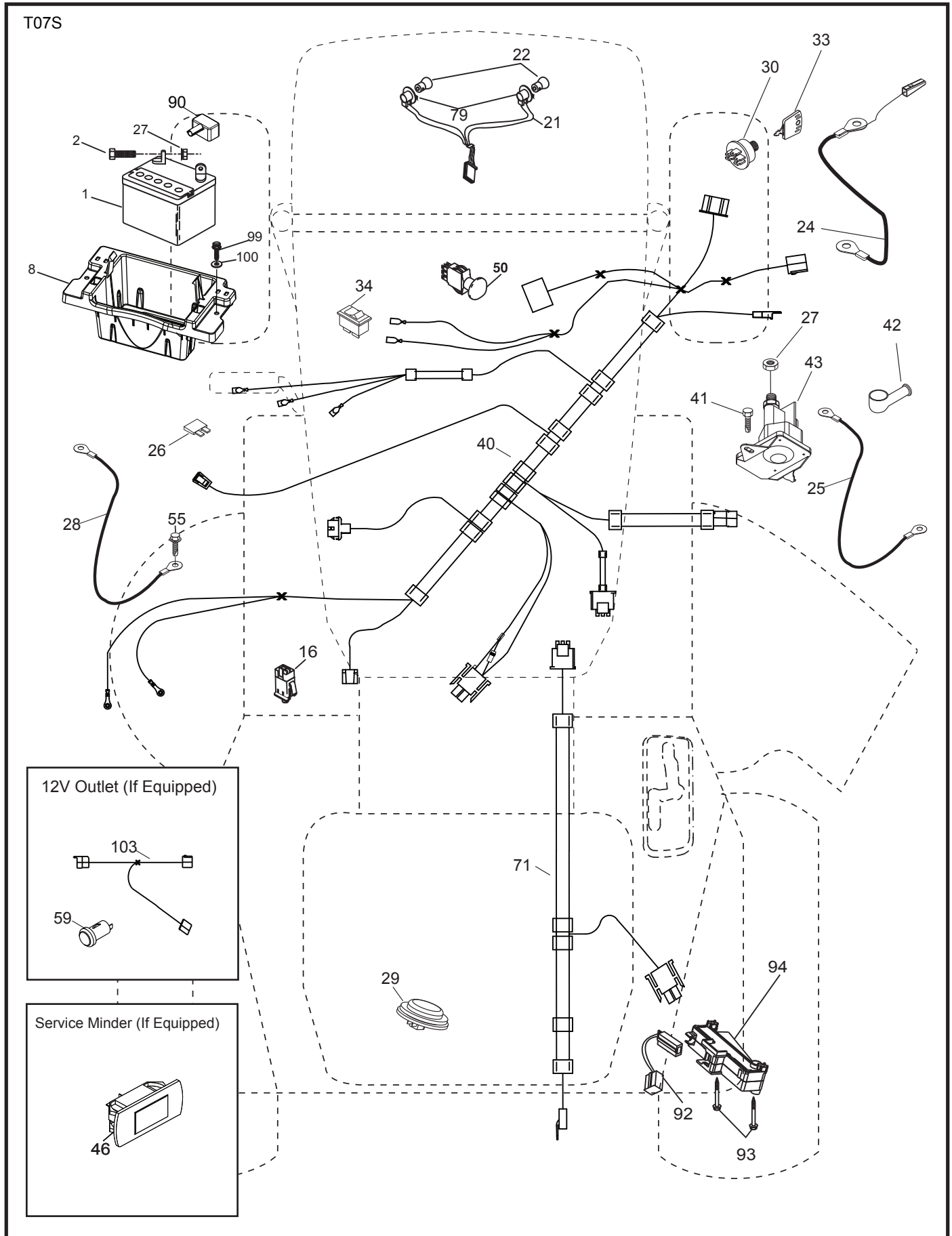

**TRACTOR - - MODEL NO. YTH150TWIN (96041002204), PRODUCT NO. 960 41 00-22
ELECTRICAL 32**

KEY NO.	PART NO.	DESCRIPTION
1	532 16 34-65	Battery
2	874 76 04-12	Bolt Hex Hd 1/4-20 unc x 3/4
8	532 18 64-91	Battery Box
16	532 17 61-38	Switch Interlock
21	532 18 37-59	Harness Socket Light
22	532 00 41-52	Bulb, Light #1156
24	532 40 02-53	Cable Battery
25	532 41 28-95	Cable Starter
26	532 17 51-58	Fuse
27	873 51 04-00	Nut Keps Hex 1/4-20 unc
28	532 14 54-91	Cable Ground 21" Blk 6 Ga.
29	532 40 15-45	Switch Seat
30	532 19 33-50	Switch Ign
33	532 41 19-35	Key/Chain
34	532 11 07-12	Switch Light/Reset
40	532 40 11-04	Harness Ign Dash
41	817 72 04-08	Screw Thd Cut 1/4-20 x 1/2
42	532 13 15-63	Cover Terminal Red
43	532 19 25-07	Solenoid
46	532 40 17-63	Gauge Hourmeter
50	532 17 46-51	Switch PTO
55	817 06 05-12	Screw Thdrol 5/16-18 x 3/4
71	532 19 42-76	Harness Ign. Chassis
79	532 17 52-42	Socket Asm. Bulb
90	532 40 07-24	Cover Terminal Battery
91	532 19 02-70	Strap Battery
92	532 19 66-15	Harness Pigtail Console
93	532 19 25-40	Screw Plastic 10-14 x 2.0
94	532 19 18-34	Module Reverse
99	817 67 04-12	Screw Hexwsh Thdrol 1/4-20 x 3/4
100	819 09 14-16	Washer 9/32 x 7/8 x 16 Ga.

NOTE: All component dimensions given in U.S. inches
1 inch = 25.4 mm

TRACTOR - - MODEL NO. YTH150TWIN (96041002204), PRODUCT NO. 960 41 00-22
CHASSIS AND ENCLOSURES **39**

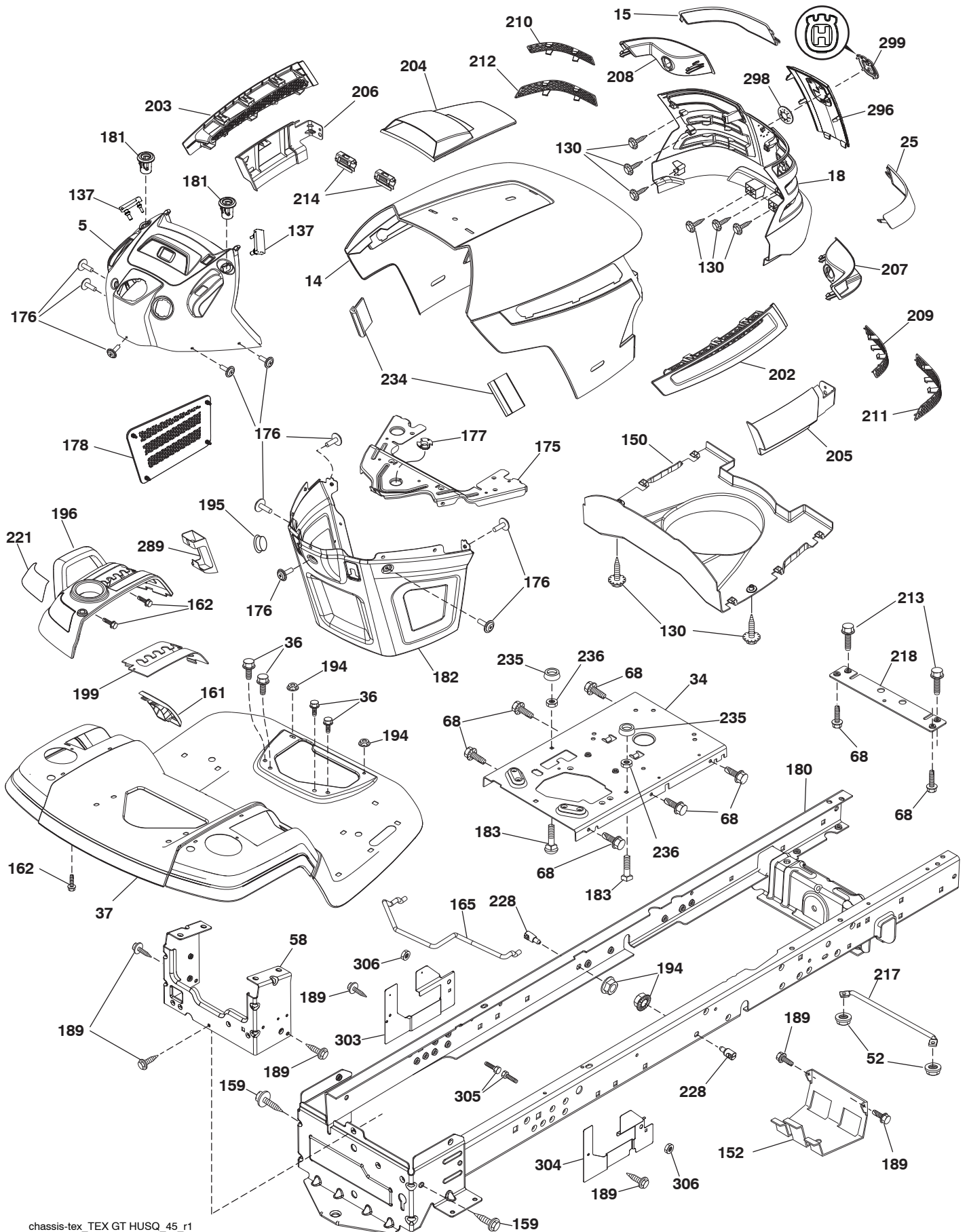

chassis-tex_TEX GT HUSQ_45_r1

**TRACTOR - - MODEL NO. YTH150TWIN (96041002204), PRODUCT NO. 960 41 00-22
CHASSIS AND ENCLOSURES 39**

KEY NO.	PART NO.	DESCRIPTION	KEY NO.	PART NO.	DESCRIPTION
5	532 44 84-43	Dash	202	532 40 30-48	Vent Side Hood RH
14	532 41 10-46	Hood	203	532 40 30-76	Vent Side Hood LH
15	532 19 89-07	Lens LH	204	532 41 66-13	Vent Asm Hood Top
18	532 40 86-07	Grille	205	532 40 17-09	Skirt Hood Side RH
25	532 19 89-06	Lens RH	206	532 40 17-11	Skirt Hood Side LH
34	532 19 61-25	Plate Engine	207	532 19 71-98	Bezel RH
36	817 06 05-12	Screw 5/16-18 x 3/4	208	532 19 71-99	Bezel LH
37	532 40 18-25	Fender	209	532 19 91-30	Insert Hex Top RH
52	873 68 05-00	Nut Crown Lock 5/16-18	210	532 19 91-31	Insert Hex Top LH
58	532 41 22-81	Drawbar, Upper	211	532 19 91-32	Insert Hex Bottom RH
68	817 49 05-08	Screw 5/16-18 x 1/2	212	532 19 91-33	Insert Hex Bottom LH
130	532 41 63-58	Screw#10 x .075 BOS Thread	213	874 76 05-12	Bolt Hex Hd 5/16-18 unc x 3/4
137	532 40 75-90	Bumper, Dash	214	532 19 91-45	Clip Retainer
150	532 19 85-14	Duct Heat Hood	217	532 40 91-67	Rod Pivot
152	532 19 95-35	Shield Browning/Debris	218	532 19 63-95	Hood Stop
159	817 00 06-12	Screw Hexwsh Thdr3/8-16 x 3/4	221	532 19 89-09	Reflector LH
161	532 40 18-26	Console Fuel Window	228	532 19 51-61	Stud Fastener
162	532 14 24-32	Screw Hex Wsh Hi-Lo 1/4 x 1/2	234	532 40 47-42	Bumper, Hood
165	532 19 68-26	Bracket Support Tank	235	532 40 61-29	Spacer Fender
175	532 19 63-04	Crossmember	236	873 93 05-00	Nut Center Lock 5/16-18 unc
176	532 40 07-76	Screw 10-24 x 5/8 Rnd Qdrx	289	532 40 35-71	Plug Cruise/Phone
177	532 19 52-27	Bushing Steering	296	532 40 86-06	Trim Husq
178	532 19 97-82	Cargo Asm. Net	298	532 11 04-52	Nut Push
180	532 41 50-64	Chassis	299	532 40 50-12	Logo
181	532 40 30-25	Bushing Mtg. Fender Crgo.	303	532 42 09-59	Shield Chassis French LH
182	532 40 68-59	Dash Lower	304	532 42 15-09	Shield Chassis French RH
183	874 52 05-20	Bolt 5/16-18 x 1-1/4	305	872 11 06-06	Bolt Rdhd. Sht. Sqnk 3/8-16 x 3/4
189	817 00 05-12	Screw 5/16-18 x 3/4	306	873 90 06-00	Nut lock Flg. 3/8-16 unc
194	873 90 05-00	Nut Lock Hex Flange 5/16-18			
195	532 40 41-37	Plug 12V Adapter			
196	532 40 02-99	Console Asm. Deck Lift			
199	532 19 82-59	Plate Deck Lift			

NOTE: All component dimensions given in U.S. inches
1 inch = 25.4 mm

TRACTOR - - MODEL NO. YTH150TWIN (96041002204), PRODUCT NO. 960 41 00-22
DRIVE **40**

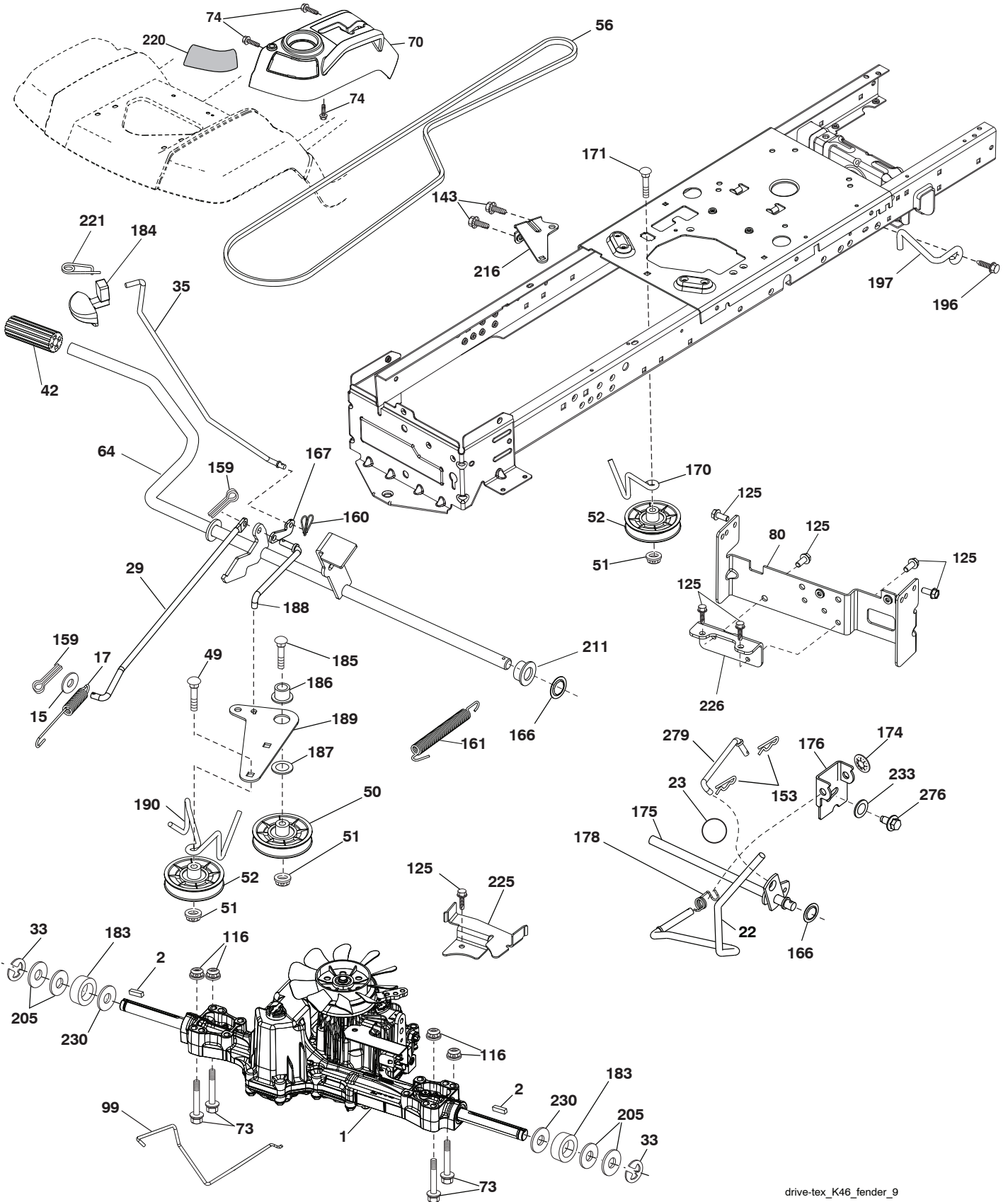

drive-tex_K46_fender_9

**TRACTOR - - MODEL NO. YTH150TWIN (96041002204), PRODUCT NO. 960 41 00-22
DRIVE **40****

KEY NO.	PART NO.	DESCRIPTION	KEY NO.	PART NO.	DESCRIPTION
1	- - - - -	Transaxle, TUFFTORQ K46 BA (Order parts from transaxle manufacturer)	170	532 19 43-22	Keeper Belt Centerspan
			171	872 11 06-16	Bolt RDHD SQNK 3/8-16 unc x 2
2	532 12 35-83	Key	174	532 19 72-89	Nut Push
15	819 13 13-16	Washer 13/32 x 13/16 x 16 Ga.	175	532 40 62-08	Shaft Asm Shift
17	532 41 36-78	Spring Brake	176	532 19 62-14	Arm Clevis Rod Shift
22	532 19 73-29	Rod Shift	178	532 19 74-56	Spring Shift
23	532 12 12-74	Knob	183	532 13 70-57	Spacer Split
29	532 40 38-06	Rod, Brake	184	532 40 31-18	Handle Parking Brake
33	812 00 00-01	Ring E	185	872 11 06-22	Bolt Rdhd Sqnk 3/8-16 x 2-3/4
35	532 19 95-91	Rod Brake Park	186	532 19 43-21	Spacer Retainer
42	532 12 48-72	Cover Foot Pedal	187	819 13 32-10	Washer
49	872 11 06-14	Bolt	188	532 19 43-23	Link Clutch Ground Drive
50	532 19 43-27	Pulley Idler Flat	189	532 19 43-17	Bellcrank Ground Drive
51	873 90 06-00	Lock Nut 3/8-16	190	532 19 43-18	Keeper Bellcrank Ground Drive
52	532 19 43-26	Idler V-Groove 910" Offset	196	817 00 06-16	Screw 3/8-16 x 1
56	532 13 09-69	V-Belt Drive	197	532 19 58-04	Link Clutch Anti-Rotation
64	532 19 62-00	Shaft Asm. Pedal Brake Control	205	532 12 17-48	Washer
70	532 40 02-98	Console	211	532 19 62-12	Bushing Brake Shaft
73	874 49 05-44	Bolt Hex Flghd 5/16-18 Gr. 5	216	532 19 61-31	Bracket Pulley Idler
74	532 14 24-32	Screw 1/4 x 1/2	220	532 19 89-08	Deflector, RH
80	532 41 00-24	Strap Torque	221	532 40 31-87	Retainer Spring Clip Handle
99	532 41 57-42	Rod Bypass Spring	225	532 40 33-19	Keeper Belt Trans.
116	873 90 05-00	Nut Lock Hex Flange 5/16-18	226	532 40 15-64	Bracket Mount Torque
125	817 00 05-12	Screw 5/16-18 x 3/4	230	532 18 89-67	Washer Hardened
143	817 49 05-08	Screw 5/16-18 x 1/2	233	532 40 52-96	Washer Serrated
153	532 12 47-88	Retainer Spring	276	874 78 07-16	Bolt 7/16-14 x 1 Gr. 5
159	876 02 04-12	Pin Cotter 1/8 x 3/4	279	532 40 62-07	Link Shift
160	532 16 94-84	Retainer Clip			
161	532 10 57-09	Spring Return Clutch			
166	532 42 83-05	Nut Push			
167	532 40 52-57	Latch Brake Parking			

NOTE: All component dimensions given in U.S. inches
1 inch = 25.4 mm

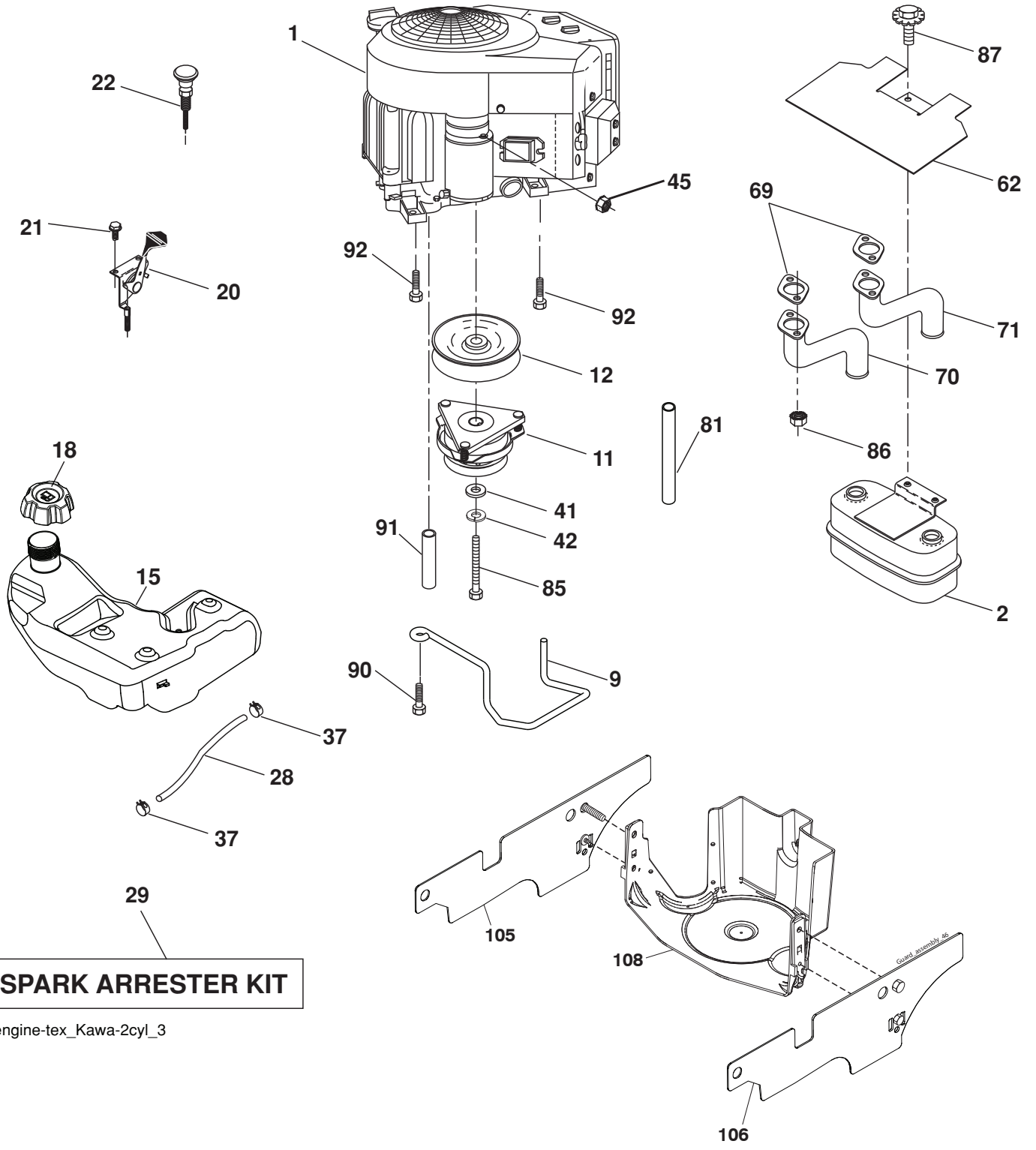

SPARK ARRESTER KIT

engine-tex_Kawa-2cyl_3

**TRACTOR - - MODEL NO. YTH150TWIN (96041002204), PRODUCT NO. 960 41 00-22
ENGINE 24**

KEY NO.	PART NO.	DESCRIPTION
1	- - - - -	Engine Kawa Model No. FH430V-DS11(Order parts from engine manufacturer)
2	532 14 97-23	Muffler
9	532 19 43-20	Keeper Belt Engine
11	532 18 05-05	Clutch Electric
12	532 40 50-97	Pulley Engine
15	532 19 34-99	Tank Fuel 4.0
18	532 43 02-17	Cap Fuel
20	532 17 83-85	Control Throttle
21	532 41 63-58	Screw #10 x 0.750 BOS Thread
22	532 19 15-96	Control Choke
28	532 14 21-58	Fuel Line
29	532 13 71-80	Spark Arrester Kit
37	532 12 34-87	Clamp Hose
41	532 12 61-97	Washer 1-1/2 OD x 15/32 ID x .250
42	810 04 07-00	Washer Lock 7/16
45	873 51 04-00	Nut Keps Hex 1/4-20 unc
62	532 14 66-29	Shield Heat Muffler
69	532 17 80-84	Gasket
70	532 18 14-44	Tube Exhaust LH
71	532 18 14-42	Tube Exhaust RH
81	532 14 84-56	Tube Drain Oil Easy
85	532 17 39-37	Bolt Hex 7/16-20 x 4 x Gr. 5-1.5
86	532 18 43-62	Nut Hex Flange Toplock M8-1.2
87	532 17 18-77	Bolt 5/16-18 x 3/4 w/Sems
90	817 00 06-16	Screw 3/8-16 x 1
91	532 18 74-95	Bushing
92	817 12 06-16	Screw 3/8-16 x 1
105	532 44 06-81	Shield Side LH
106	532 44 06-80	Shield Side RH
108	532 42 17-94	Cover Asm Engine

NOTE: All component dimensions given in U.S. inches
1 inch = 25.4 mm

TRACTOR - - MODEL NO. YTH150TWIN (96041002204), PRODUCT NO. 960 41 00-22
STEERING ASSEMBLY **41**

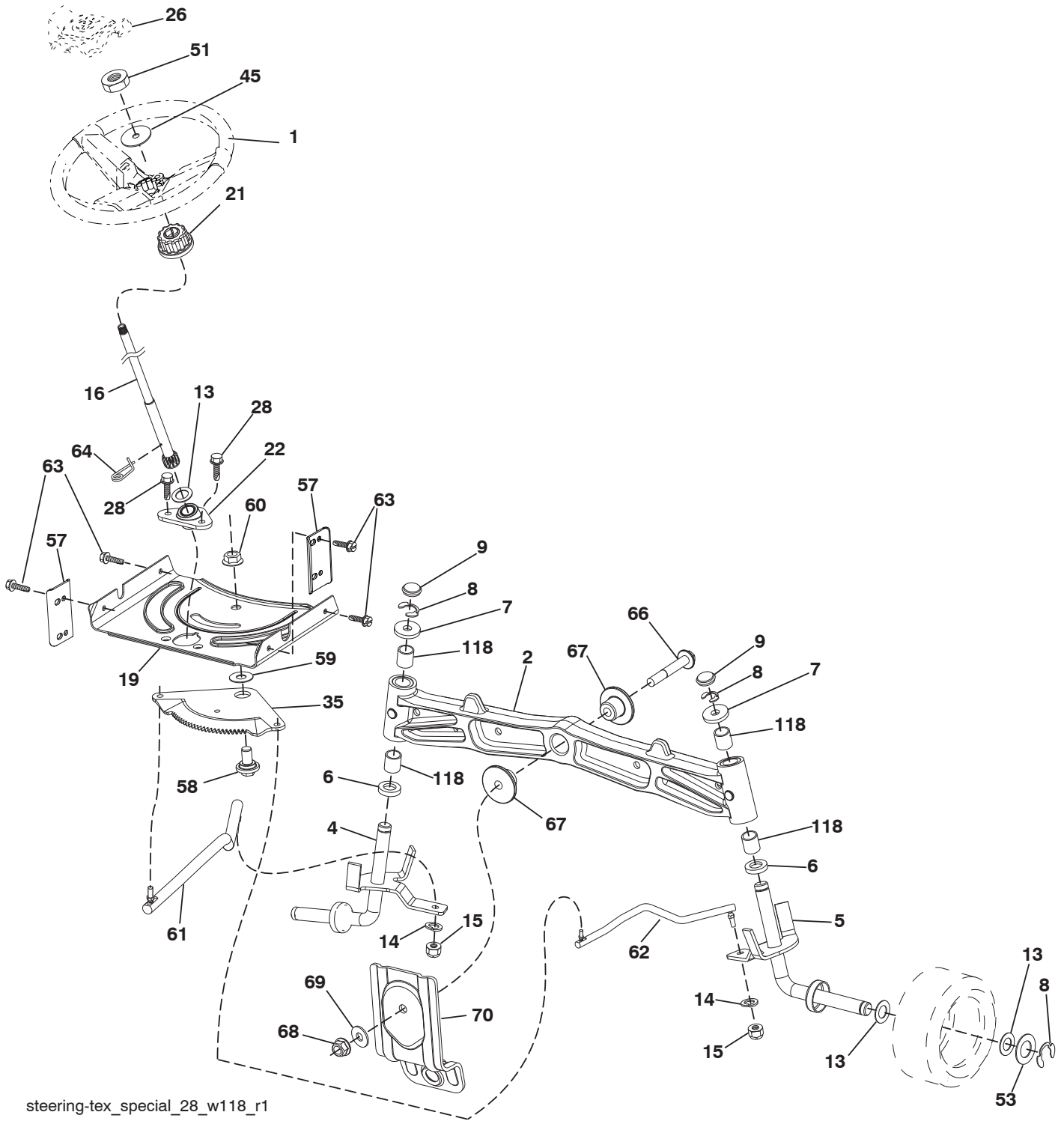

steering-tex_special_28_w118_r1

**TRACTOR - - MODEL NO. YTH150TWIN (96041002204), PRODUCT NO. 960 41 00-22
STEERING ASSEMBLY **41****

KEY NO.	PART NO.	DESCRIPTION
1	532 41 64-80	Wheel, Steering Husq SR
2	532 41 35-91	Axle Asm., Front
4	532 40 30-87	Spindle Asm., LH
5	532 40 30-88	Spindle Asm., RH
6	532 12 49-31	Bearing, Race Thrust Harden
7	532 12 17-48	Washer 25/32 x 1-5/8 x 16 Ga.
8	812 00 00-29	Ring, Klip #T5304-75
9	532 12 12-32	Cap, Spindle
13	532 12 17-49	Washer 25/32 x 1-1/4 x 16 Ga.
14	810 04 06-00	Washer, Lock Hvy Hlcl Spr 3/8
15	873 54 06-00	Nut, Crown Lock 3/8-24 unf
16	532 19 47-46	Shaft Steering
19	532 19 47-29	Plate Steering
21	532 18 67-37	Adapter, Wheel Steering
22	532 42 05-37	Steering Support Lower
26	532 41 59-87	Insert, Wheel Steering Husq SR
28	817 00 06-12	Screw 3/8-16 x 3/4
35	532 19 47-32	Gear, Sector Plate
45	819 18 38-12	Washer 9/16 x 2-3/8 x 12 Ga.
51	873 94 08-00	Nut Hex Jam Toplock 1/2-20 unf
53	532 18 89-67	Washer Hardened .793 x 1.637 x .060
57	532 40 74-65	Bracket Upstop
58	532 19 47-47	Bolt Shoulder Sector Pivot CFM
59	532 19 47-48	Washer Thrust Sector Steering
60	873 97 10-00	Nut Flange Lock 5/8-11
61	532 19 47-40	Draglink, LH
62	532 19 47-41	Draglink, RH
63	817 00 05-12	Screw 5/16-18 x 3/4
64	532 19 98-49	Retainer Clip Spring Steering
66	871 02 07-48	Bolt Hex Fghd 7/16-14 x 3 Serr
67	532 19 47-37	Bushing PM Front Axle
68	873 90 07-00	Nut Lock Flange 7/16-14 Gr. 5
69	532 19 91-62	Washer 1.5 x .505 x .118
70	532 19 61-97	Bracket Deck Susp. Front
118	532 40 60-13	Bushing

NOTE: All component dimensions given in U.S. inches
1 inch = 25.4 mm

TRACTOR - - MODEL NO. YTH150TWIN (96041002204), PRODUCT NO. 960 41 00-22
MOWER DECK **44**

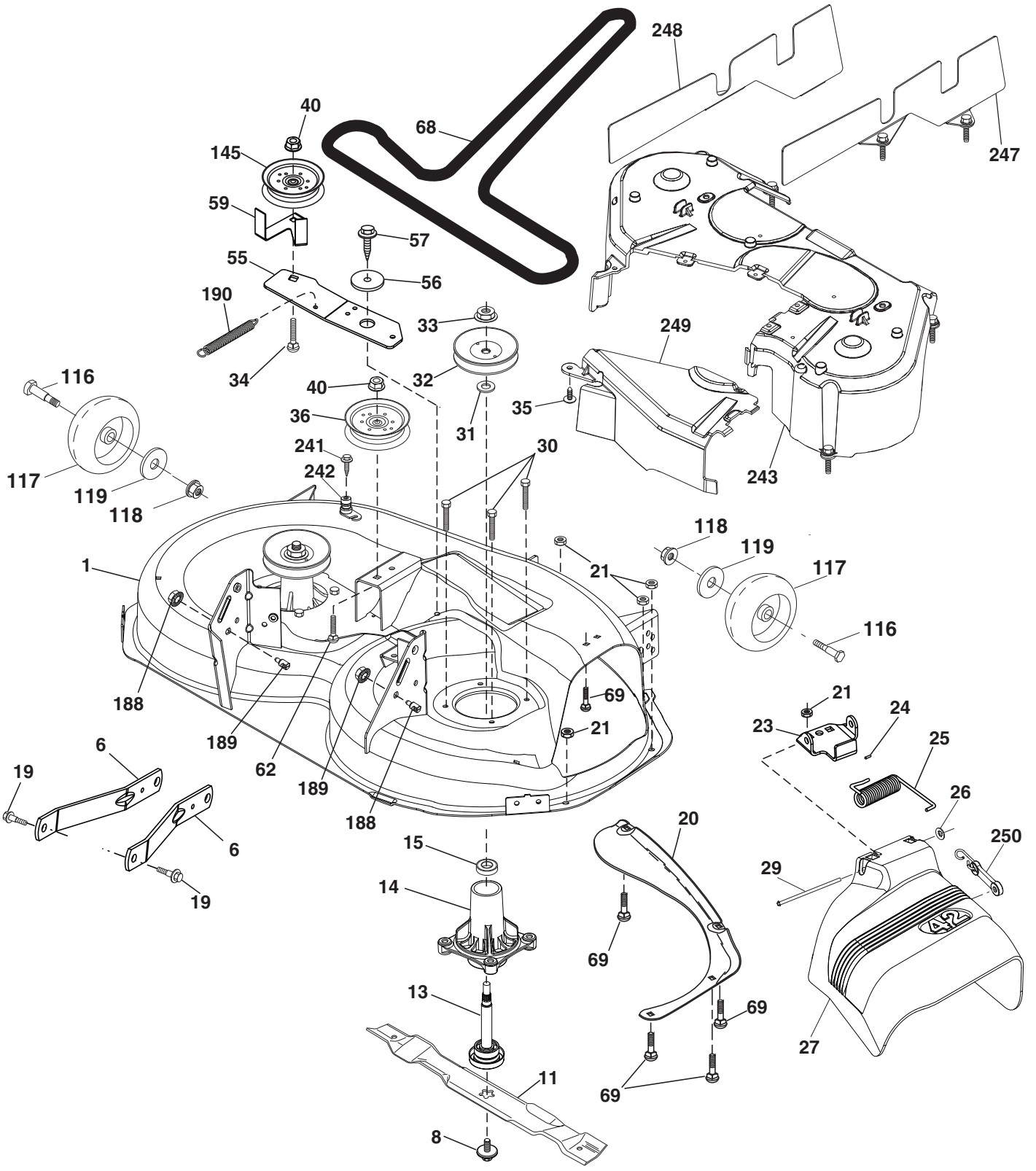

42_D_elec-tex_22_r1

**TRACTOR - - MODEL NO. YTH150TWIN (96041002204), PRODUCT NO. 960 41 00-22
MOWER DECK 44**

KEY NO.	PART NO.	DESCRIPTION	KEY NO.	PART NO.	DESCRIPTION
1	532 19 64-95	Mower Deck Assembly, 42"	68	532 14 49-59	V-Belt, 42" Mower
6	532 19 51-86	Arm Susp. Rear	69	872 14 05-05	Bolt, Carriage 5/16-18 x 5/8
8	532 19 30-03	Bolt/Washer Asm 7/16-20 unf (The following Blades are available)	116	532 12 48-42	Bolt, Shoulder
11	532 13 89-71	Blade Mower 42" Hi-Lift (for bagging and discharging)	117	532 18 86-06	Wheel, Gauge
13	532 19 28-72	Shaft Assembly, Mandrel	118	873 90 06-00	Nut Centerlock 3/8-16
14	532 18 72-81	Housing, Mandrel	119	819 12 14-14	Washer 3/8 x 7/8 x 14
15	532 11 04-85	Bearing, Ball, Mandrel	145	532 19 31-97	Pulley Idler
19	532 19 65-39	Bolt, Shoulder	188	532 19 51-61	Stud Fastner W/D Anti-Rotation
20	532 15 97-70	Baffle, Vortex	189	873 90 05-00	Nut Lock Hex Flange 5/16-18
21	873 68 05-00	Nut	190	532 19 72-51	Spring Mower Drive
23	532 19 25-57	Bracket, Deflector Mower 42"	241	532 15 29-27	Screw
24	532 10 53-04	Cap, Sleeve 80 x 112 Blk Mower	242	532 41 55-98	Port Washout
25	532 19 70-26	Spring, Torsion, Deflector	243	532 43 23-94	Cover Deck 42"
26	532 11 04-52	Nut, Push Phos & Oil	247	532 43 23-93	Shield Deck RH
27	532 41 14-85	Shield, Deflector 42"	248	532 43 23-92	Shield Deck LH
29	532 13 14-91	Rod, Hinge 42" 6 75 W/G	249	532 40 65-14	Cover Cable Clutch
30	532 17 39-84	Screw Thdrol	250	532 43 60-87	Kit Bungee (Includes Phillips head screw, weld nut, screw, bungee latch, and bungee strap)
31	532 18 76-90	Washer, Spacer Mower Vented	--	532 19 28-70	Mandrel Assembly (Includes housing, shaft assembly, and bearing only - pulley/nut/washer and blade bolt/washers not included)
32	532 15 35-35	Pulley, Mandrel	--	532 43 17-01	Replacement Mower, Complete (Std. deck Order separately gauge wheel componants Key Nos. 116-119)
33	532 40 02-34	Nut, Toplock			
34	872 11 06-12	Bolt Carr SH 3/8-16 x 1-1/2 Gr.5			
35	532 13 38-35	Fastener, Christmas Tree			
36	532 19 73-79	Pulley, Idler, Flat			
40	873 90 06-00	Nut Lock 3/8-16			
55	532 43 71-10	Arm, Idler			
56	532 19 90-92	Spacer, Retainer			
57	817 00 06-16	Screw 3/8-16 x 1			
59	532 14 10-43	Guard TUV Idler			
62	872 11 06-16	Bolt Rdhd Sqnk 3/8-16 unc x 2			

NOTE: All component dimensions given in U.S. inches
1 inch = 25.4 mm

**TRACTOR - - MODEL NO. YTH150TWIN (96041002204), PRODUCT NO. 960 41 00-22
MOWER LIFT 45**

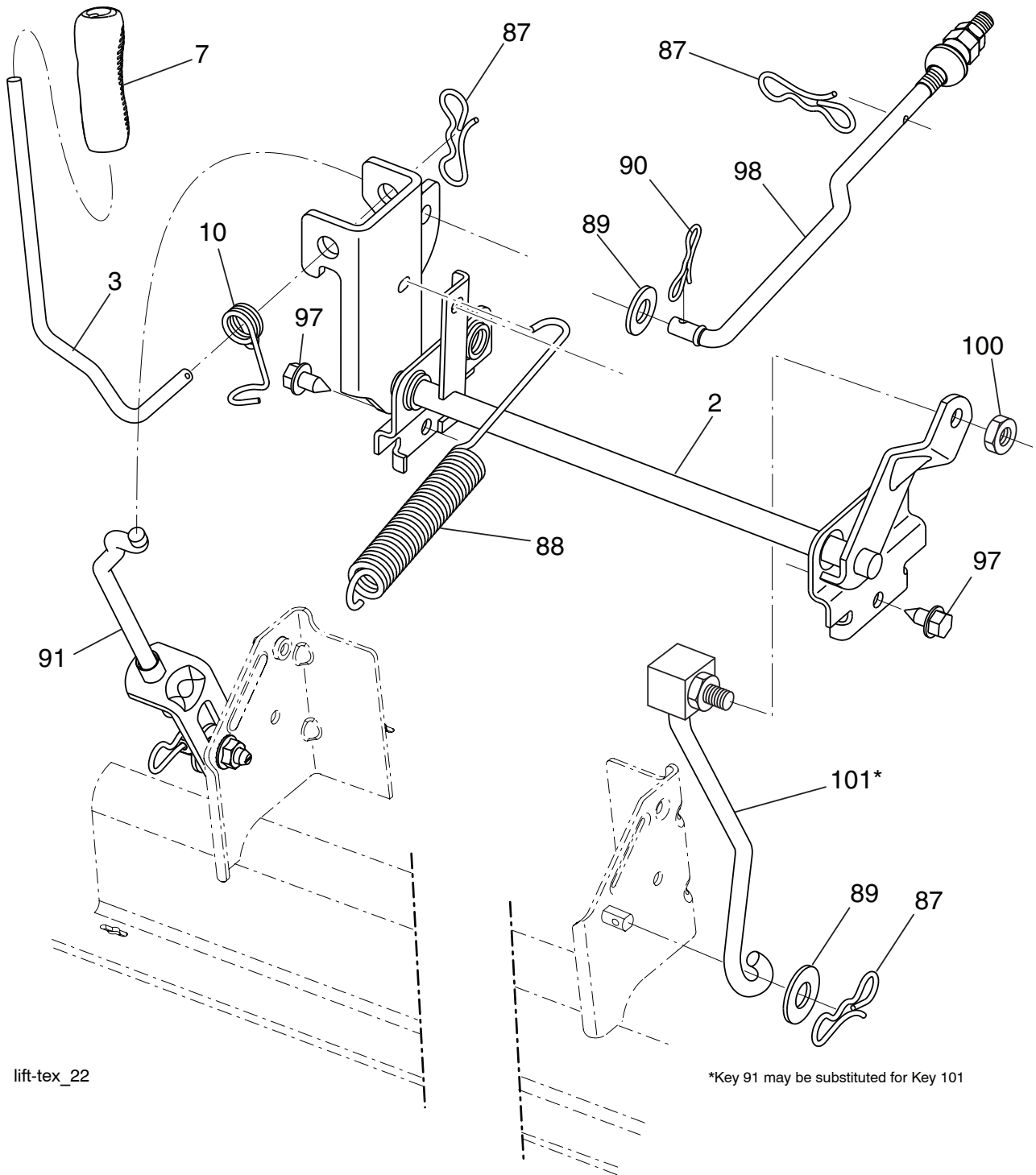

lift-tex_22

*Key 91 may be substituted for Key 101

KEY NO.	PART NO.	DESCRIPTION
2	532 42 20-27	Shaft Asm., Lift
3	532 19 52-30	Lever Asm., Lift RH
7	532 41 15-55	Grip, Lever
10	532 19 63-14	Spring Torsion
87	532 19 42-09	Pin Cotter 7/16 Bow Tie Lock
88	532 41 07-10	Spring Lift Assist
89	819 19 19-12	Washer Clear Zinc
90	532 19 42-08	Pin Cotter 5/16 Bow Tie Lock

KEY NO.	PART NO.	DESCRIPTION
91	532 19 51-81	Link Lift Susp Mower Rear
97	817 00 06-12	Screw 3/8-16 x .75 Smgml Tap/R.Z
98	532 19 52-70	Link Lift Susp. Front Mower
100	873 93 06-00	Nut Lock 3/8 - 16 unc
101	532 40 70-03	Link Asm. Lift Fxd

NOTE: All component dimensions given in U.S. inches
1 inch = 25.4 mm

**TRACTOR - - MODEL NO. YTH150TWIN (96041002204), PRODUCT NO. 960 41 00-22
SEAT ASSEMBLY 42**

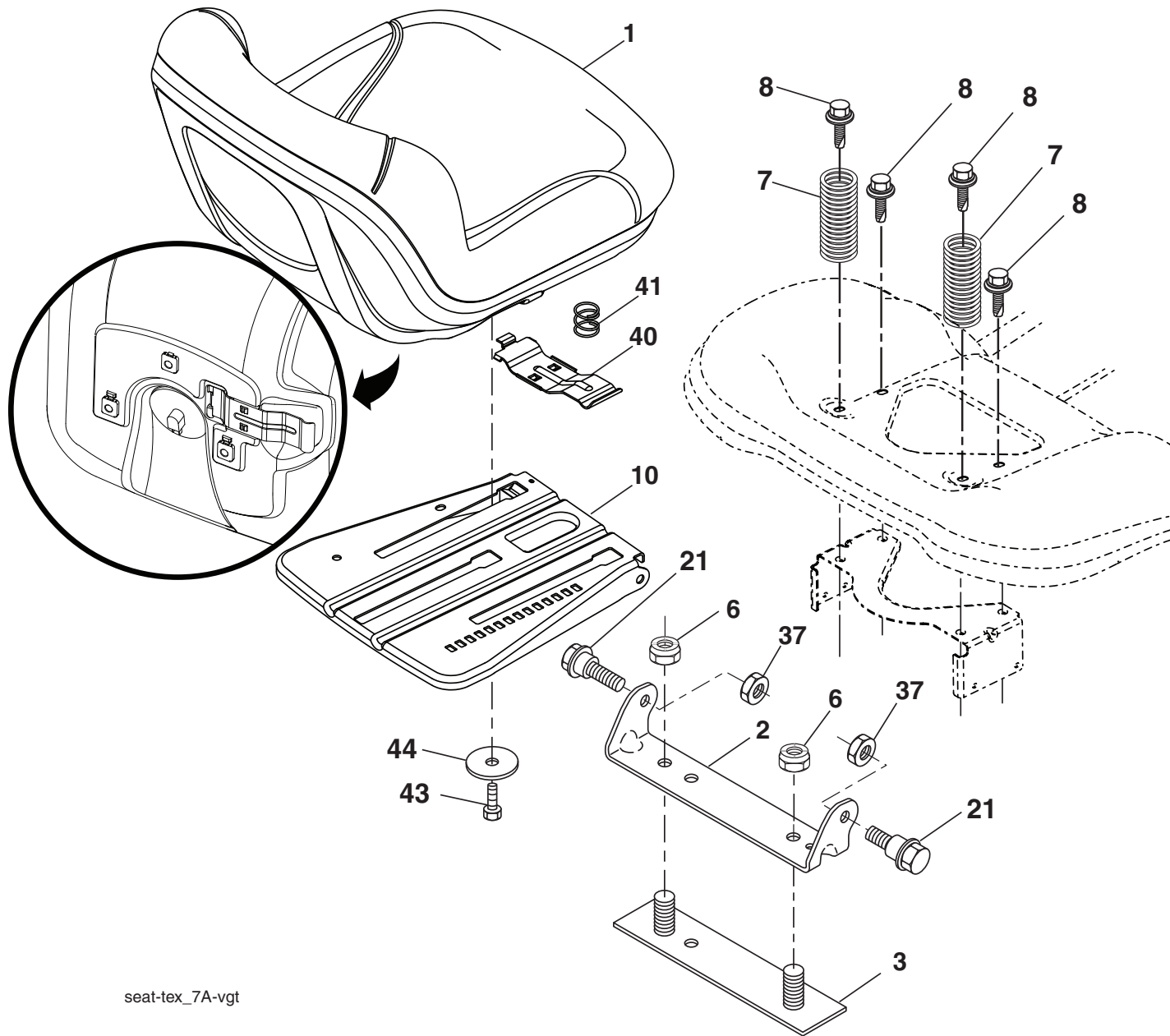

seat-tex_7A-vgt

KEY NO.	PART NO.	DESCRIPTION
1	532 42 40-68	Seat
2	532 18 01-66	Bracket Pivot Fender
3	532 14 06-75	Strap, Asm Fender
4	873 80 06-00	Nut, Lock w/Ins. 3/8-16 unc
5	532 12 41-81	Spring, Seat Cprsn
6	532 17 18-77	Bolt 5/16-18 unc x 3/4 w/Sems
7	532 19 69-77	Pan, Seat
8	532 17 18-52	Bolt, Shoulder 5/16-18
9	873 80 05-00	Nut, Lock 5/16-18 unc

KEY NO.	PART NO.	DESCRIPTION
10	532 19 76-61	Handle Slide Seat
11	532 19 82-00	Spring Latch Seat
12	874 76 06-12	Bolt 3/8-16 x 3/4
13	819 13 38-12	Washer 13/32 x 2-3/8 x 12 Ga.

NOTE: All component dimensions given in U.S. inches
1 inch = 25.4 mm

