

YTH220 TWIN

Spare parts

Ersatzteile

Pièces détachées

Reserve onderdelen

Repuestos

Reservdelar

ILLUSTRATED PARTS LIST

MODEL NO. 96041002803

CUSTOMER CATALOG NO. YTH220 TWIN

PRODUCT NO. 960 41 00-28

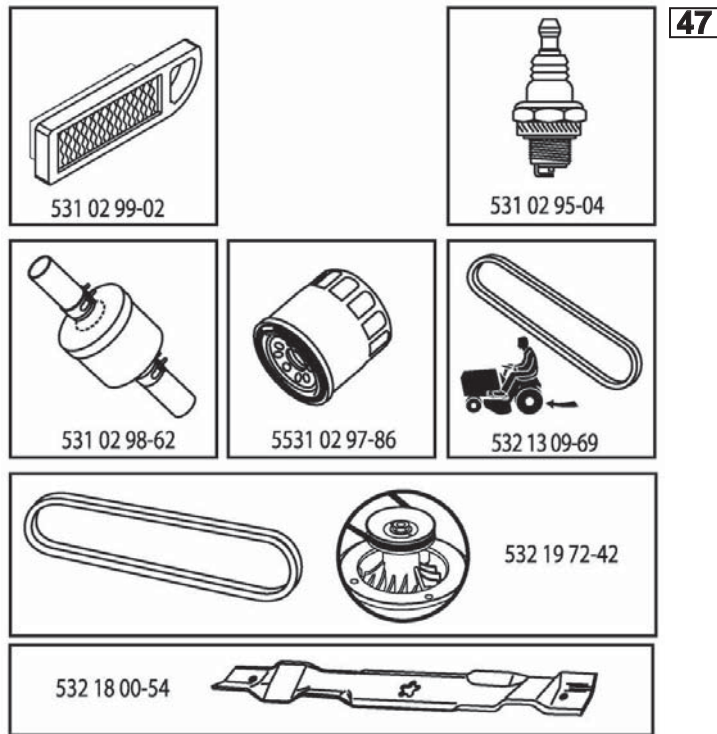

408775

**TRACTOR -- MODEL NO. YTH220 TWIN (96041002803), PRODUCT NO.960 41 00-28
DECALS 27**

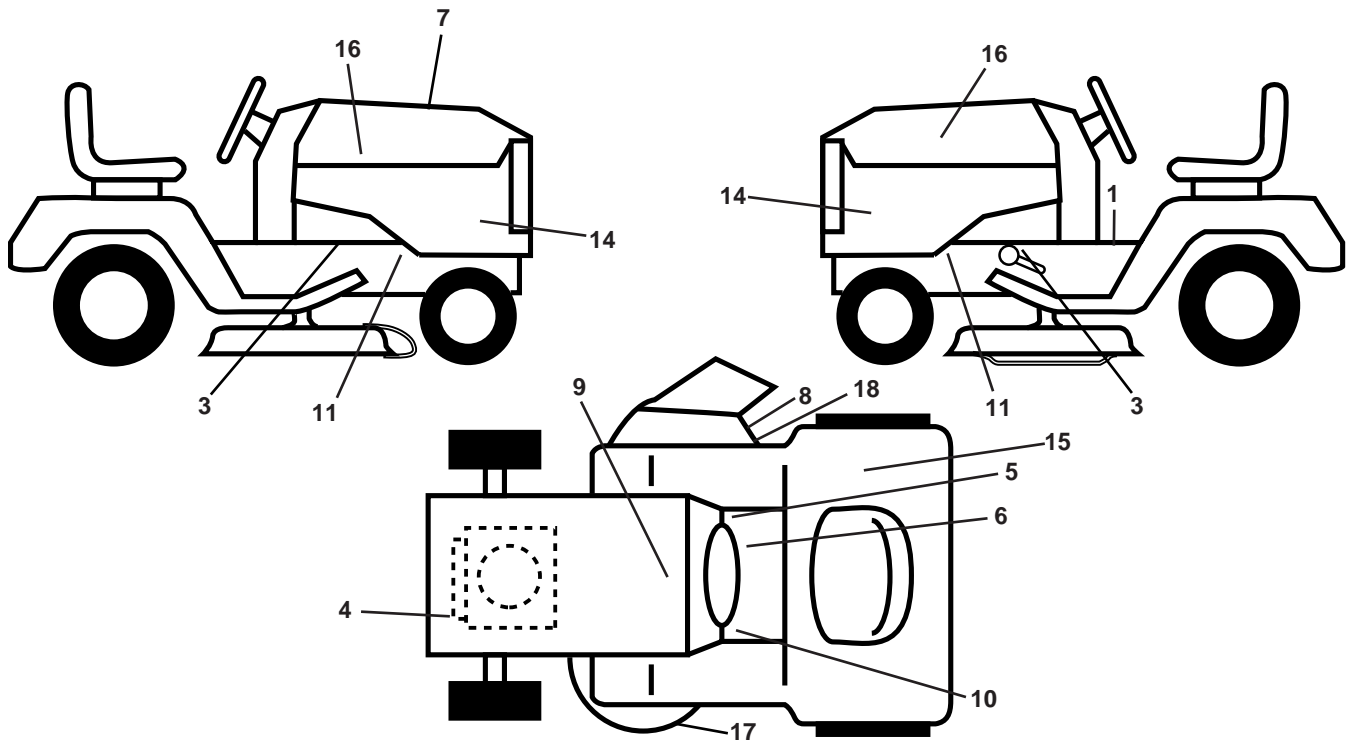

KEY NO.	PART NO.	DESCRIPTION
1	532 40 03-89	Decal, Warning Syms. CE
3	532 40 11-46	Decal, Warning Service/Fire
4	532 19 68-41	Decal, Warning Eng. Syms.
5	532 14 08-37	Decal, Saddle Brake Parking
6	532 17 83-02	Decal, Oper Cruise Sym.
7	532 40 87-75	Decal, Replacement
8	532 18 21-66	Decal, Cutfinger CE
9	532 14 50-05	Decal, Battery Dnge/Poison
10	532 15 97-37	Decal, Brake/Clutch Sym
11	532 15 97-36	Decal, Chassis Hot Muffler

KEY NO.	PART NO.	DESCRIPTION
14	532 40 88-46	Decal, Panel Side
15	532 18 04-33	Decal, Fender
16	532 42 91-96	Decal, Badge
17	532 19 87-85	Decal, Mower Sch.
18	532 19 63-57	Decal, Warning Cutfinger
--	532 16 25-98	Decal, Drawbar Load Limit
--	532 16 69-60	Decal, Bypass
--	532 40 17-71	Pad, Footrest, LH
--	532 40 37-73	Pad, Footrest, RH
--	532 43 26-18	Manual, Operator's Euro

WHEELS AND TIRES

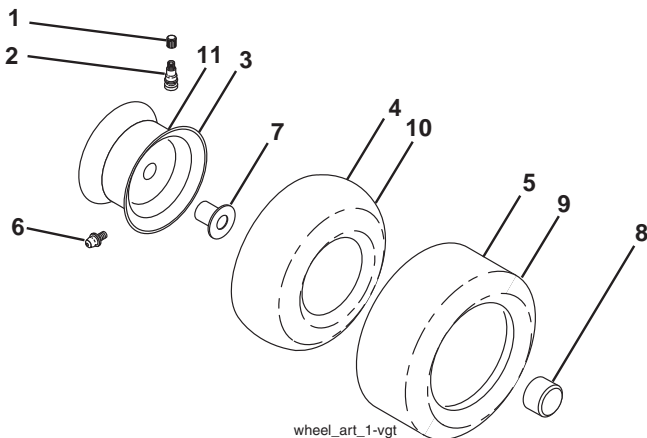

KEY NO.	PART NO.	DESCRIPTION
1	532 05 91-92	Cap, Valve, Tire
2	532 06 51-39	Stem, Valve
3	532 14 45-09	Rim Assembly, Front
4	532 00 81-34	Tube, Front (Service Item Only)
5	532 10 62-30	Tire, Front
6	532 12 49-57	Fitting, Grease (Front Wheel Only)
7	532 12 49-59	Bearing, Flange (Front Wheel Only)
8	532 17 50-39	Cap, Axle (Front Wheel Only)
9	532 18 47-08	Tire, Rear
10	532 00 71-54	Tube, Rear (Service Item Only)
11	532 40 17-82	Rim Assembly, Rear
--	532 14 43-34	Sealant, Tire (10 oz. Tube)

NOTE: All component dimensions given in U.S. inches
1 inch = 25.4 mm

TRACTOR -- MODEL NO. YTH220 TWIN (96041002803), PRODUCT NO.960 41 00-28

SCHEMATIC 38

SCH12

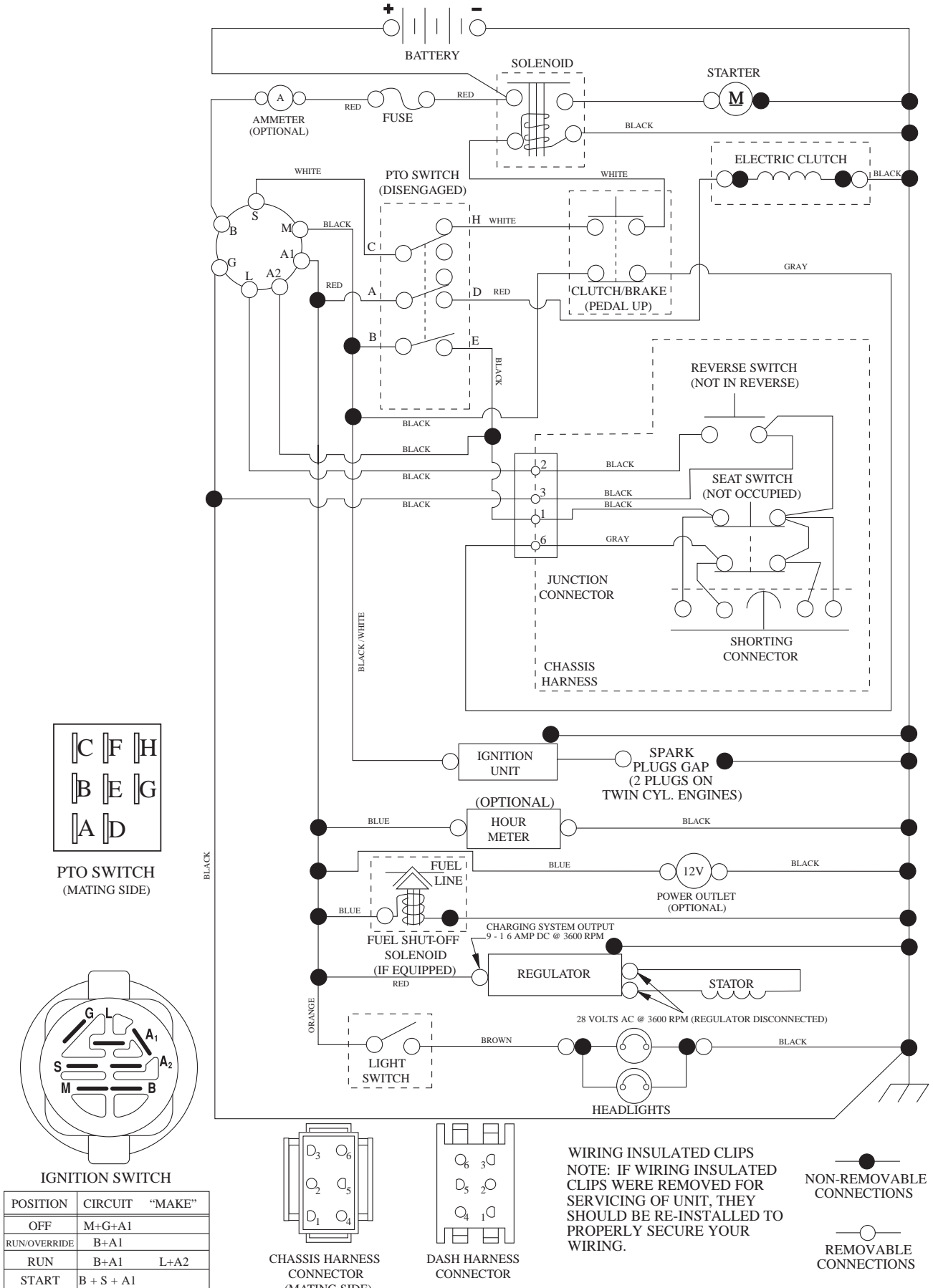

**TRACTOR -- MODEL NO. YTH220 TWIN (96041002803), PRODUCT NO.960 41 00-28
ELECTRICAL 32**

KEY NO.	PART NO.	DESCRIPTION
1	532 16 34-65	Battery
2	874 76 04-12	Bolt Hex Hd 1/4-20 unc x 3/4
8	532 18 64-91	Battery Box
16	532 17 61-38	Switch Interlock
21	532 18 37-59	Harness Socket Light
22	532 00 41-52	Bulb, Light #1156
24	532 40 02-53	Cable Battery
25	532 41 28-95	Cable Starter
26	532 17 51-58	Fuse
27	873 51 04-00	Nut Keps Hex 1/4-20 unc
28	532 14 54-91	Cable Ground 21" Blk 6 Ga.
29	532 40 15-45	Switch Seat
30	532 19 33-50	Switch Ignition
33	532 41 19-35	Key/Chain
34	532 11 07-12	Switch Light/Reset
40	532 40 11-04	Harness Ignition Dash
41	817 72 04-08	Screw Thd Cut 1/4-20 x 1/2
42	532 13 15-63	Cover Terminal Red
43	532 19 25-07	Solenoid
46	532 40 17-63	Gauge Hourmeter
50	532 17 46-51	Switch PTO
55	817 06 05-12	Screw Thdrol 5/16-18 x 3/4
71	532 19 42-76	Harness Ignition
79	532 17 52-42	Socket Asm. Bulb Twistlock
90	532 40 07-24	Cover Terminal Battery
91	532 19 02-70	Strap Battery
99	817 67 04-12	Screw Hexwsh Thdrol 1/4-20 x 3/4
100	819 09 14-16	Washer 9/32 x 7/8 x 16 Ga.
102	532 40 44-54	Harness Pigtail
105	532 40 75-68	Switch Reverse

NOTE: All component dimensions given in U.S. inches
1 inch = 25.4 mm

TRACTOR -- MODEL NO. YTH220 TWIN (96041002803), PRODUCT NO.960 41 00-28
CHASSIS AND ENCLOSURES **39**

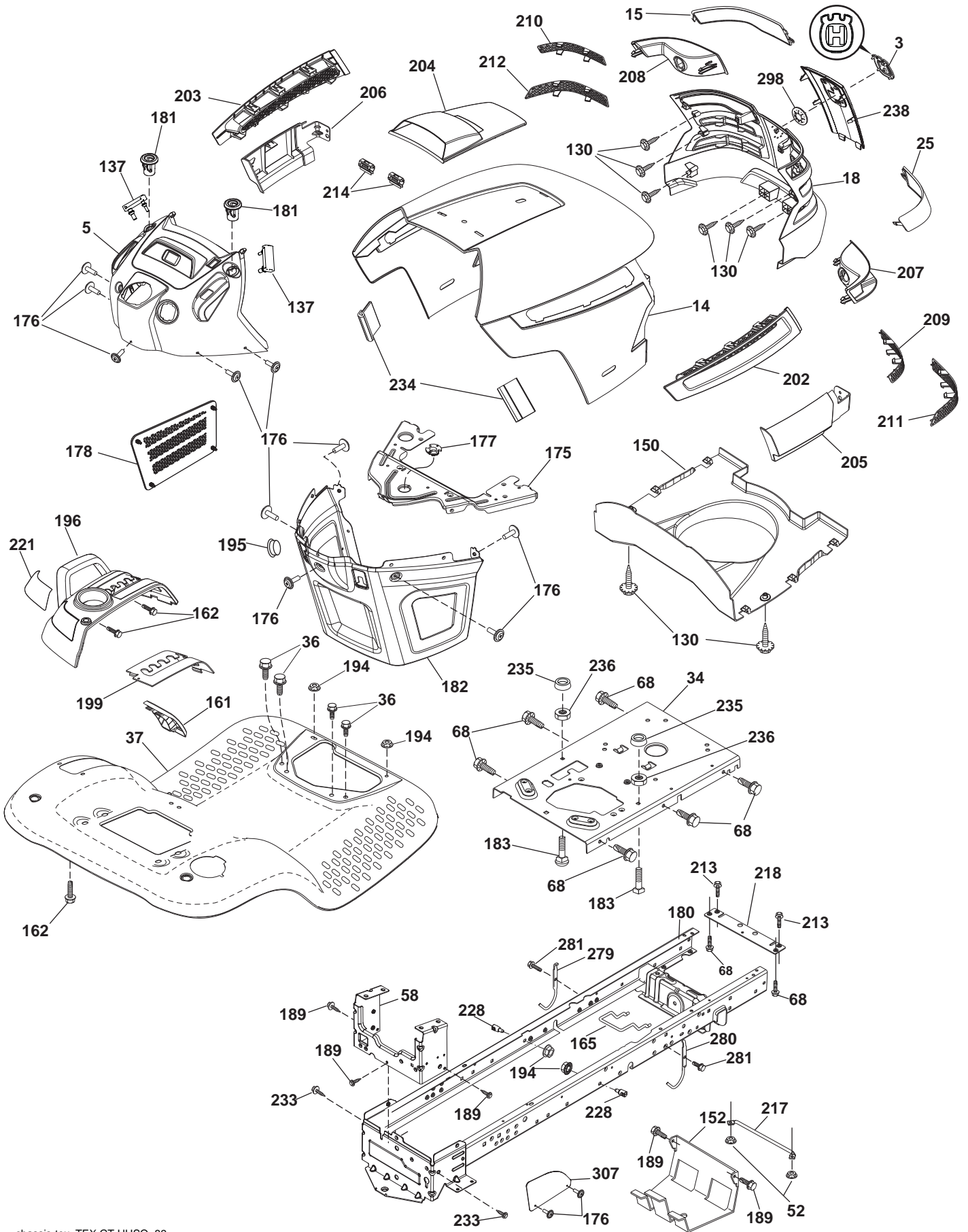

**TRACTOR -- MODEL NO. YTH220 TWIN (96041002803), PRODUCT NO.960 41 00-28
CHASSIS AND ENCLOSURES 39**

KEY PART NO. NO.	DESCRIPTION	KEY PART NO. NO.	DESCRIPTION	
3	532 40 50-12	202	532 40 30-48	Vent Side Hood RH
5	532 44 84-43	203	532 40 30-76	Vent Side Hood LH
14	532 41 10-46	204	532 41 66-13	Vent Top Hood
15	532 19 89-07	205	532 40 17-09	Skirt Hood Side RH
18	532 40 86-07	206	532 40 17-11	Skirt Hood Side LH
25	532 19 89-06	207	532 19 71-98	Bezel RH
34	532 19 61-25	208	532 19 71-99	Bezel LH
36	817 06 05-12	209	532 19 91-30	Insert Hex Top RH
37	532 40 18-25	210	532 19 91-31	Insert Hex Top LH
52	873 68 05-00	211	532 19 91-32	Insert Hex Bottom RH
58	532 41 22-81	212	532 19 91-33	Insert Hex Bottom LH
68	817 49 05-08	213	874 76 05-12	Bolt 5/16-18 unc x 3/4
130	532 41 63-58	214	532 19 91-45	Clip Retainer Tinner
137	532 40 75-90	217	532 40 91-67	Rod Pivot
150	532 19 85-12	218	532 19 63-95	X-Piece Hood Stop
152	532 19 95-35	221	532 19 89-09	Reflector LH
161	532 40 18-26	228	532 19 51-61	Stud Fastner
162	532 14 24-32	233	532 19 65-39	Bolt Shoulder
165	532 19 68-26	234	532 40 47-42	Bumper Hood
175	532 19 63-04	235	532 40 61-29	Spacer Fender
176	532 40 07-76	236	873 93 05-00	Nut Lock 5/16-18 unc
177	532 19 52-27	238	532 40 86-06	Trim
178	532 19 97-82	279	532 40 26-80	Rod Upstop LH
180	532 41 50-63	280	532 40 26-81	Rod Upstop RH
181	532 40 30-25	281	817 00 06-16	Screw 3/8-16 x 1
182	532 40 68-59	298	532 11 04-52	Nut Push
183	874 52 05-20	307	532 42 45-70	Shield Upper Pedal
189	817 00 05-12	--	532 43 18-83	Kit Bumper
194	873 90 05-00			
195	532 40 51-37			
196	532 40 02-99			
199	532 19 82-59			

NOTE: All component dimensions given in U.S. inches
1 inch = 25.4 mm

**TRACTOR -- MODEL NO. YTH220 TWIN (96041002803), PRODUCT NO.960 41 00-28
DRIVE **40****

KEY NO.	PART NO.	DESCRIPTION	KEY NO.	PART NO.	DESCRIPTION
1	---	Transaxle, TUFFTORQ K46 BN	170	532 41 34-30	Keeper Belt Centerspan
2	532 18 62-11	Key .187 x 2.50	183	532 40 04-24	Spacer Split
7	532 19 98-44	Hub Asm. Wheel Rear	184	532 40 31-18	Handle Parking Brake
9	532 14 00-80	Bolt Hub Wheel Rear	185	872 11 06-22	Bolt Rdhd Sqnk 3/8-16 x 2-3/4 Gr. 5
15	819 13 13-16	Washer 13/32 x 13/16 x 16 Ga.	186	532 19 43-21	Spacer Retainer
17	532 41 36-78	Spring, Brake	187	819 13 32-10	Washer
26	532 19 96-79	Spring Return Cruise	188	532 19 43-23	Link Clutch Ground Drive
29	532 40 38-06	Rod, Brake	189	532 19 43-17	Bellcrank Ground Drive
33	812 00 00-01	Ring E	190	532 19 43-18	Keeper Bellcrank Ground Drive
35	532 19 95-91	Rod, Brake, Park	196	817 00 06-16	Screw 3/8-16 x 1
42	532 12 48-72	Cover, Foot Pedal	197	532 19 97-69	Link Clutch Anti-Rotation
49	872 11 06-14	Bolt	205	532 12 17-48	Washer
50	532 19 43-27	Pulley Idler Flat	206	532 19 78-67	Bracket Mount Latch Cruise
51	873 90 06-00	Lock Nut 3/8-16	207	532 19 78-68	Latch Control Cruise
52	532 19 43-26	Idler V-Groove 910" Offset	208	532 19 78-69	Gear Sector Control Cruise
56	532 13 09-69	V-Belt, Drive	209	532 19 95-92	Rod Control Cruise
64	532 19 78-65	Shaft Asm. Pedal Brake Control	210	532 19 78-60	Rocker Asm. Pedal Control
70	532 40 05-30	Console Asm.	211	532 12 01-83	Bearing Nylon
73	874 49 05-44	Bolt Hex Flghd 5/16-18 Gr. 5	213	532 40 31-19	Knob Control Cruise
74	532 14 24-32	Screw 1/4 x 1/2	214	532 42 12-63	Pedal Forward
80	532 41 00-24	Bracket Strap Torque	215	532 40 17-23	Pedal Reverse
92	874 76 05-20	Bolt Fin Hex 5/16-18 unc x 1.25	216	532 19 61-31	Bracket Pulley Idler
99	532 41 57-42	Rod Bypass	220	532 19 89-08	Reflector RH
116	873 90 05-00	Nut Lock Hex Flange 5/16-18	221	532 40 31-87	Retainer Spring Clip Handle
125	817 00 05-12	Screw 5/16-18 x 3/4	222	879 21 20-10	Washer 21/32 x 1-1/4 x 10 Ga.
143	817 49 05-08	Screw 5/16-18 x 1/2	225	532 40 33-19	Keeper Belt Trans.
153	532 12 47-88	Retainer Spring	226	532 40 15-64	Bracket Mount Torque
159	876 02 04-12	Pin Cotter 1/8 x 3/4	230	532 18 89-67	Washer Hardened
160	532 16 94-84	Retainer Clip	231	532 40 72-87	Idler V-Groove 1.688" Offset
161	532 10 57-09	Spring, Return, Clutch			
163	532 40 10-34	Rod Pedal Control			
166	532 42 91-64	Nut Push .625			
167	532 40 52-57	Latch Brake Parking			

NOTE: All component dimensions given in U.S. inches
1 inch = 25.4 mm

**TRACTOR -- MODEL NO. YTH220 TWIN (96041002803), PRODUCT NO.960 41 00-28
ENGINE 24**

KEY NO.	PART NO.	DESCRIPTION
1	-----	Engine Kohl Model No. SV715-0011
2	532 14 97-23	Muffler
9	532 19 43-20	Keeper Belt Engine
11	532 17 93-35	Clutch Electric
12	532 19 43-43	Pulley Engine
15	532 19 34-99	Tank Fuel 4.0
18	532 43 02-17	Cap Asm Fuel
20	532 18 29-37	Control Throttle
21	532 41 63-58	Screw #10 x 0.750 BOS THREAD
22	532 19 15-96	Control Choke
28	532 14 21-58	Fuel Line
29	532 13 71-80	Spark Arrester Kit
37	532 12 34-87	Clamp Hose
41	532 12 61-97	Washer 1-1/2 OD x 15/32 ID x .250
42	810 04 07-00	Washer Lock 7/16
45	873 51 04-00	Nut Keps Hex 1/4-20 unc
62	532 43 40-17	Shield Heat Muffler
69	532 18 60-54	Gasket
70	532 14 66-99	Tube Exhaust LH
71	532 14 67-00	Tube Exhaust RH
79	532 19 23-34	Screw Socket Head 5/16-18 x .75
81	532 14 84-56	Tube Drain Oil Easy
82	532 42 82-87	Valve Drain Oil
84	817 12 06-16	Screw 3/8-16 x 1
85	532 17 99-53	Bolt Hex 7/16-20 x 3.75 Gr. 5
87	532 17 18-77	Bolt 5/16-18 unc x 3/4
90	817 00 06-16	Screw 3/8-16 x 1
91	532 18 74-95	Bushing
108	532 43 50-56	Cover Asm Engine

NOTE: All component dimensions given in U.S. inches
1 inch = 25.4 mm

TRACTOR -- MODEL NO. YTH220 TWIN (96041002803), PRODUCT NO.960 41 00-28
STEERING ASSEMBLY **41**

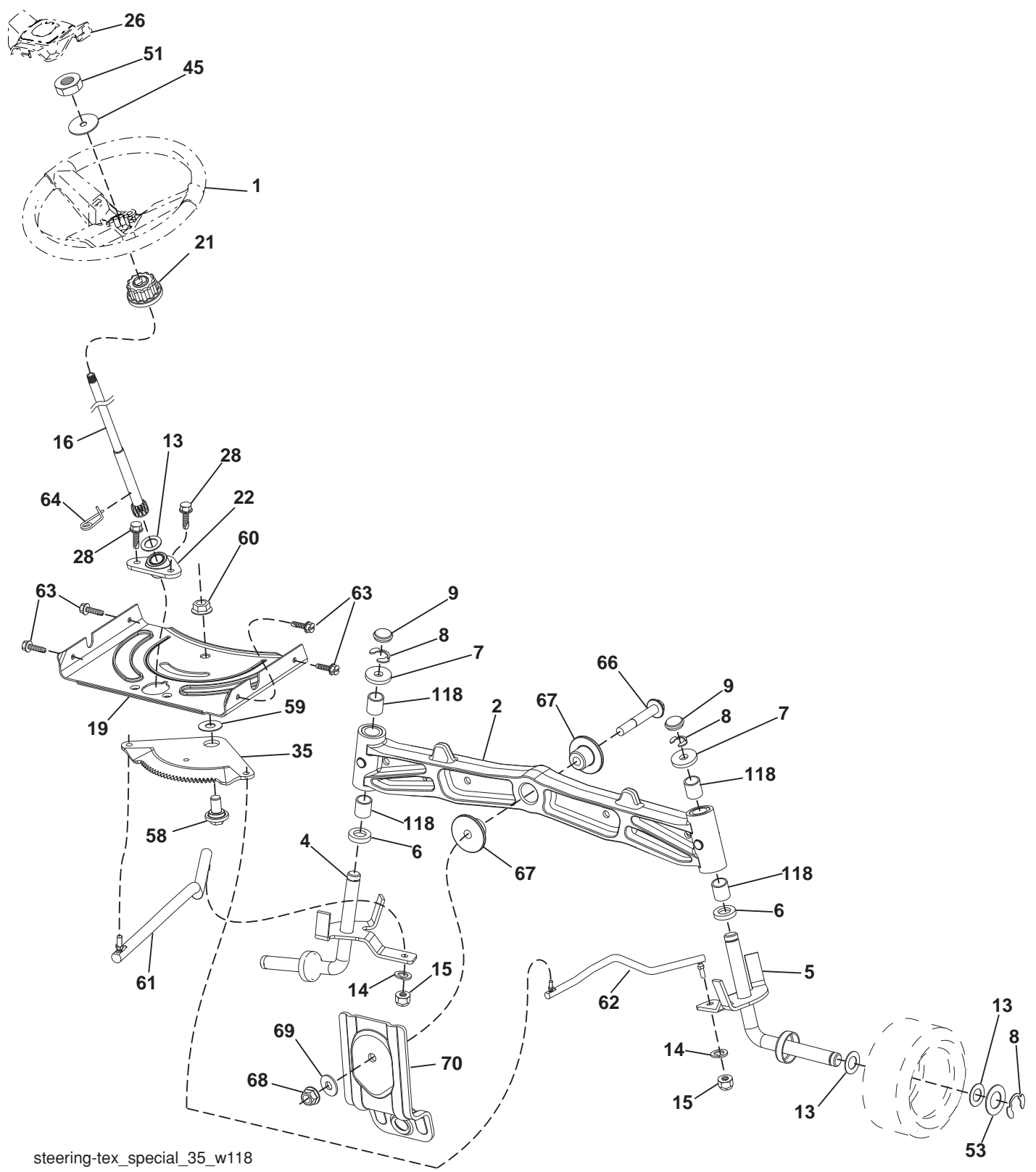

steering-tex_special_35_w118

**TRACTOR -- MODEL NO. YTH220 TWIN (96041002803), PRODUCT NO.960 41 00-28
STEERING ASSEMBLY **41****

KEY NO.	PART NO.	DESCRIPTION
1	532 41 64-80	Wheel, Steering Husq SR
2	532 41 35-91	Axle Asm., Front
4	532 40 31-72	Spindle Asm., LH
5	532 40 31-73	Spindle Asm., RH
6	532 12 49-31	Bearing, Race Thrust Harden
7	532 12 17-48	Washer 25/32 x 1-5/8 x 16 Ga.
8	812 00 00-29	Ring, Clip #T5304-75
9	532 12 12-32	Cap, Spindle
13	532 12 17-49	Washer 25/32 x 1-1/4 x 16 Ga.
14	810 04 06-00	Washer, Lock Hvy Hlcl Spr 3/8
15	873 54 06-00	Nut, Crown Lock 3/8-24 unf
16	532 19 47-46	Shaft Steering
19	532 19 47-29	Plate Steering
21	532 18 67-37	Adapter, Wheel Steering
22	532 42 05-37	Strg. Supt. Lower
26	532 41 59-87	Insert, Wheel Steering Husq SR
28	817 00 06-12	Screw 3/8-16 x 3/4
35	532 19 47-32	Gear, Sector Plate
45	819 18 38-12	Washer 9/16 x 2-3/8 x 12 Ga.
51	873 94 08-00	Nut Hex Jam Toplock 1/2-20 unf
53	532 18 89-67	Wshr Hardened .793 x 1.637 x .060
58	532 19 47-47	Bolt Shoulder Sector Pivot CFM
59	532 19 47-48	Washer Thrust Sector Steering
60	873 97 10-00	Nut Flange Lock 5/8-11
61	532 19 47-40	Draglink, LH
62	532 19 47-41	Draglink, RH
63	817 00 05-12	Screw 5/16-18 x 3/4
64	532 19 98-49	Retainer Clip Spring Steering
66	871 02 07-48	Bolt Hex Fghd 7/16-14 x 3 Serr
67	532 19 47-37	Bushing PM Front Axle
68	873 90 07-00	Nut Lock Flange 7/16-14 Gr. 5
69	532 19 91-62	Washer 1.5 x .505 x .118
70	532 19 61-97	Bracket Deck Susp. Front
118	532 40 60-13	Bushing

NOTE: All component dimensions given in U.S. inches
1 inch = 25.4 mm

TRACTOR -- MODEL NO. YTH220 TWIN (96041002803), PRODUCT NO.960 41 00-28
 MOWER DECK **44**

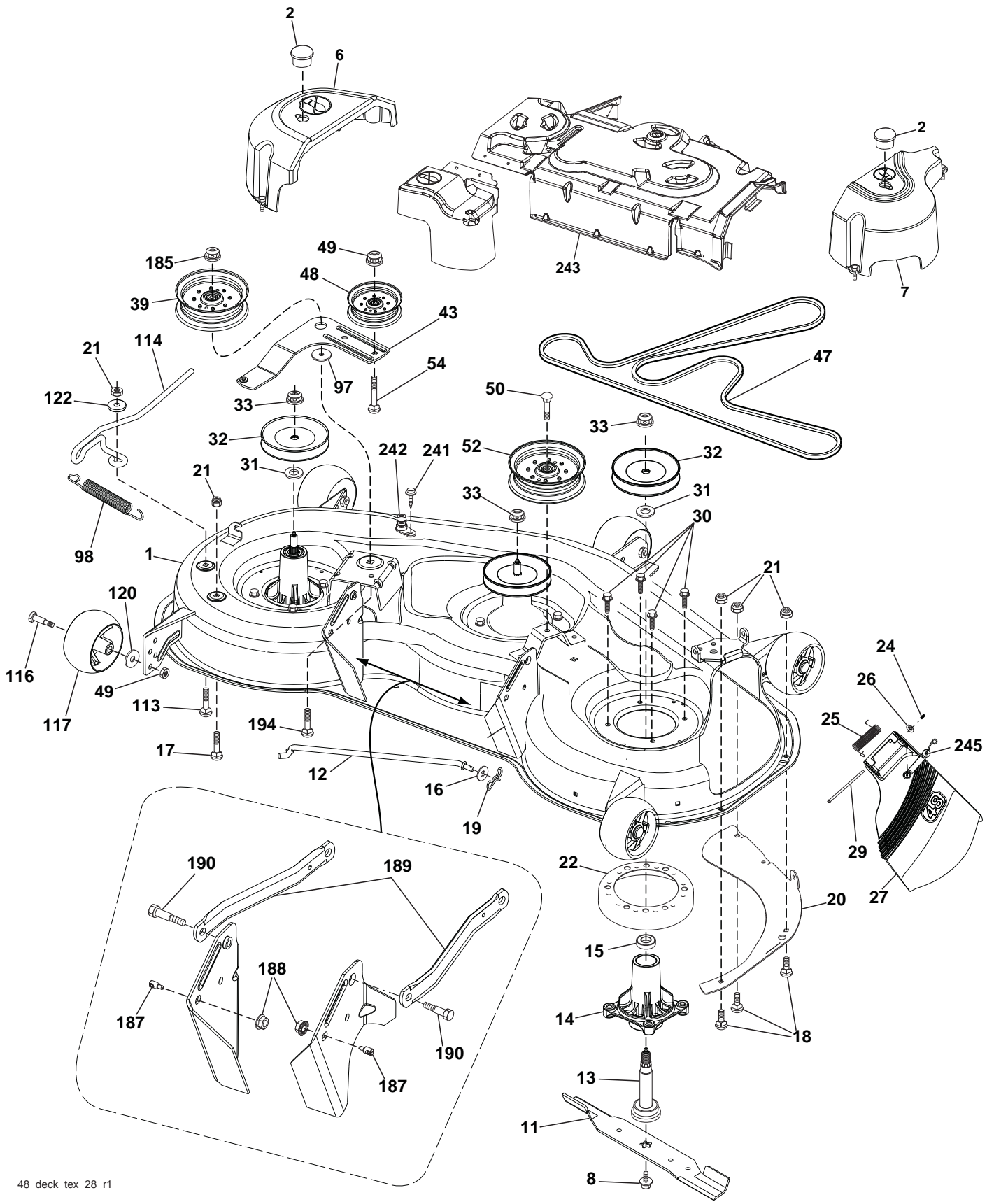

48_deck_tex_28_r1

**TRACTOR -- MODEL NO. YTH220 TWIN (96041002803), PRODUCT NO.960 41 00-28
MOWER DECK 44**

KEY NO.	PART NO.	DESCRIPTION	KEY NO.	PART NO.	DESCRIPTION
1	532 40 42-65	Deck Weldment Mower	54	872 11 06-12	Bolt Carr. Sh 3/8-16 x 1-1/2 Gr. 5
2	532 17 83-45	Plug Hole Mandrel	97	532 17 85-15	Washer Hardened
6	532 43 49-57	Cover Mandrel LH	98	532 19 61-05	Spring Drive
7	532 43 49-56	Cover Mandrel RH	113	872 11 05-08	Bolt Rdhd Sqnk 5/16-18 x 3/4
8	532 19 30-03	Blot/Washer Asm 7/16-20 unf	114	532 19 74-51	Rod Tension Relief
11	532 18 00-54	Blade High Lift	116	532 19 34-06	Bolt, Shoulder
12	532 40 48-51	Rod Anti-Sway	117	532 17 48-73	Gauge Wheel
13	532 18 72-91	Shaft Asm. w/Lower Bearing	120	819 13 20-12	Washer 13/32 x 1-1/4 x 12 Ga.
14	532 18 72-81	Housing, Mandrel	122	532 18 75-57	Bushing Tension Relief
15	532 11 04-85	Bearing, Ball, Mandrel	185	873 90 07-00	Nut Lock Flange 7/16-14 Gr. 5
16	819 13 13-12	Washer 13/32 x 13/16 x 12 Ga.	187	532 19 51-61	Stud Fastener w/"D" Anti-Rotation
17	872 11 05-05	Bolt 5/16-18 x 5/8	188	873 90 05-00	Nut Lock Hex Flange
18	872 14 05-05	Bolt RdHd 5/16-18 unc x 5/8	189	532 19 51-85	Arm Susp. Mower Rear
19	532 19 42-08	Pin Cotter 5/16 Bow Tie Lock	190	532 19 65-39	Bolt Shoulder
20	532 17 43-78	Baffle Vortex	194	872 14 07-16	Bolt Carr Sqnk 7/16-24 x 2
21	873 68 05-00	Nut, Crownlock 5/16-18 unc	241	532 15 29-27	Screw TT #10-32.5.3/8 Flange
22	532 17 44-93	Stripper Mandrel	242	532 41 55-98	Port Washout
24	532 10 53-04	Cap Sleeve	243	532 43 52-19	Cover Asm Deck 48"
25	532 17 81-02	Spring, Torsion	245	532 43 60-87	Kit Bungee (Includes Phillips head screw, weld nut, screw, bungee latch, and bungee strap)
26	532 11 04-52	Nut, Push			
27	532 41 18-61	Deflector Shield			
29	532 13 14-91	Rod, Hinge	- - -	532 18 72-92	Mandrel Assembly (Includes housing, shaft assembly, and bearing only - pulley/nut/washer and blade bolt/washers not included)
30	532 17 39-84	Screw, Thdroll Washer Head			
31	532 18 76-90	Washer, Spacer Mower Vented			
32	532 15 35-32	Pulley, Mandrel			
33	532 40 02-34	Nut, Flg. Top Lock	- - -	532 43 17-35	Replacement Mower, Complete
39	532 19 73-80	Pulley, Idler			
43	532 19 60-65	Arm, Idler			
47	532 19 72-42	Belt Deck Drive			
48	532 19 31-97	Pulley Idler			
49	873 90 06-00	Nut, Lock Flg. 3/8-16 unc			
50	817 49 06-36	Screw TT 3/8-16 x 2-1/4			
52	532 19 73-79	Pulley Idler Clutching			

NOTE: All component dimensions given in U.S. inches
1 inch = 25.4 mm

TRACTOR -- MODEL NO. YTH220 TWIN (96041002803), PRODUCT NO.960 41 00-28
MOWER LIFT 45

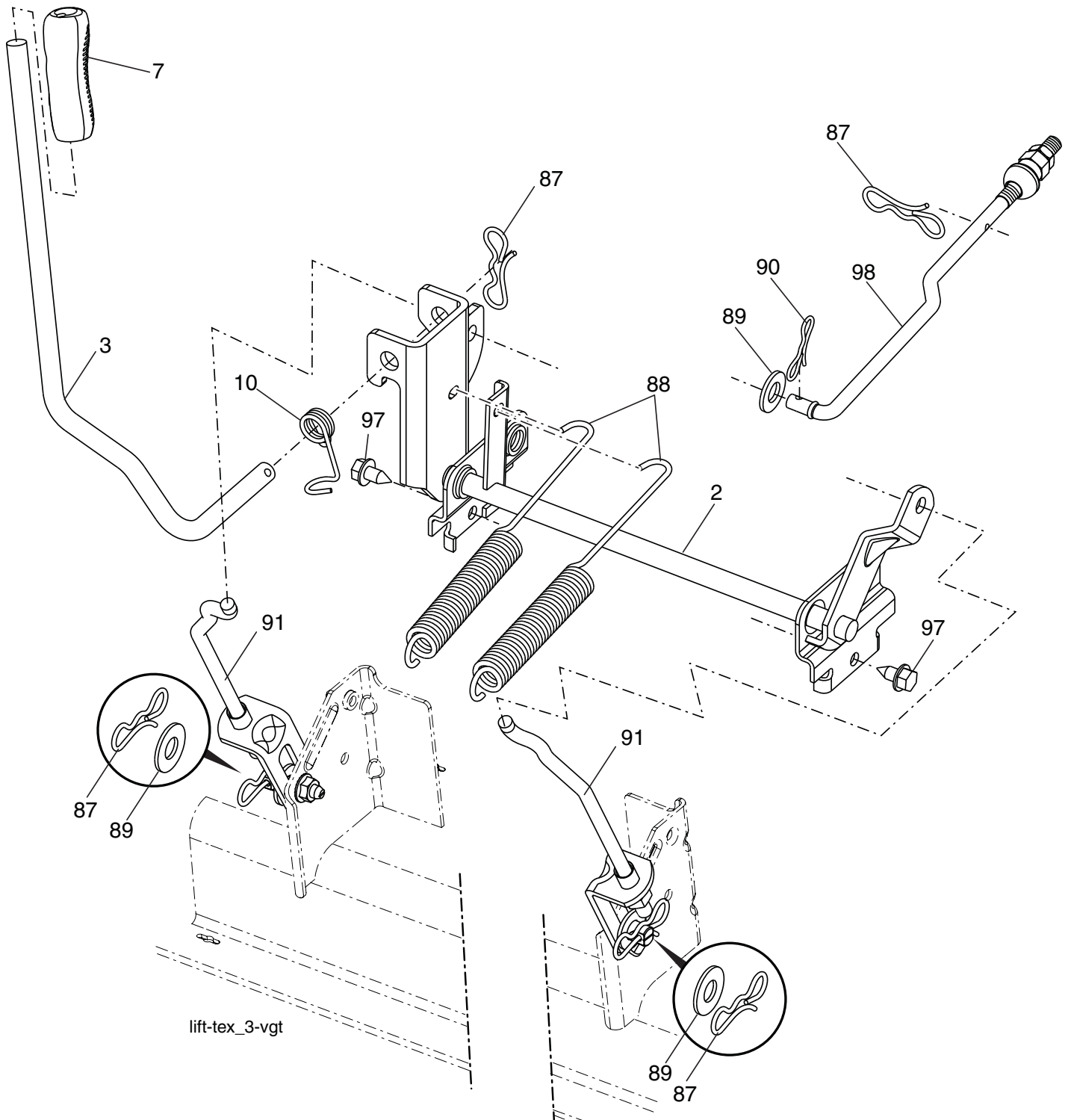

KEY NO.	PART NO.	DESCRIPTION
2	532 42 20-27	Shaft Asm., Lift
3	532 19 52-30	Lever Asm., Lift RH
7	532 41 15-55	Grip, Lever
10	532 19 63-14	Spring Torsion
87	532 19 42-09	Pin Cotter 7/16 Bow Tie Lock
88	532 41 07-10	Spring Lift Assist
89	819 19 19-12	Washer Clear Zinc

KEY NO.	PART NO.	DESCRIPTION
90	532 19 42-08	Pin Cotter 5/16 Bow Tie Lock
91	532 19 79-84	Link Lift Susp Mower Rear
97	817 00 06-12	Screw 3/8-16 x .75 Smgml Tap/R.Z
98	532 19 52-64	Link Lift Susp. Front Mower

NOTE: All component dimensions given in U.S. inches
 1 inch = 25.4 mm

**TRACTOR -- MODEL NO. YTH220 TWIN (96041002803), PRODUCT NO.960 41 00-28
SEAT ASSEMBLY 42**

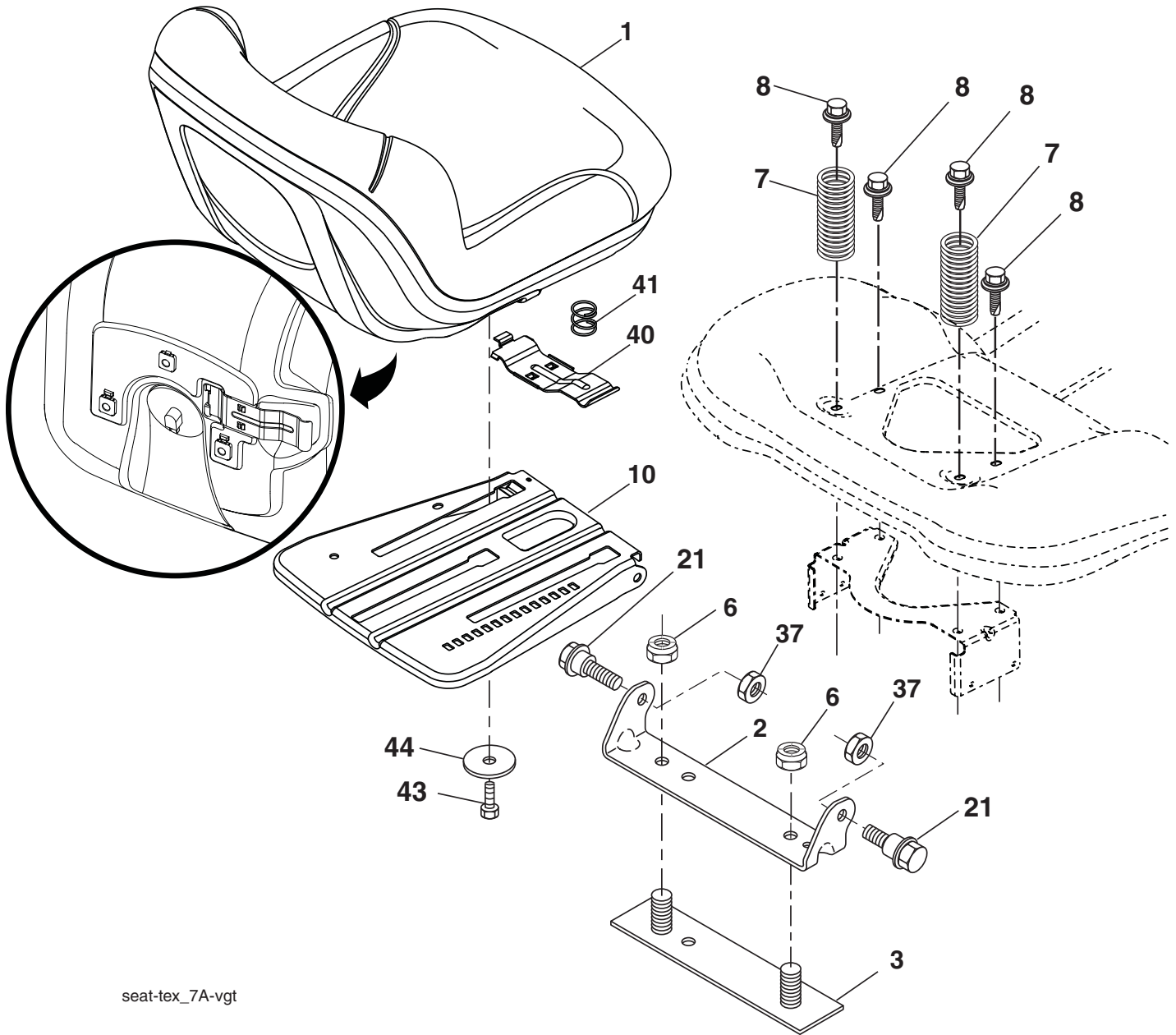

seat-tex_7A-vgt

KEY NO.	PART NO.	DESCRIPTION
1	532 42 40-68	Seat
2	532 18 01-66	Bracket Pivot Fender
3	532 14 06-75	Strap, Asm Fender
6	873 80 06-00	Nut, Lock w/Ins. 3/8-16 unc
7	532 12 41-81	Spring, Seat Cprsn
8	532 17 18-77	Bolt 5/16-18 unc x 3/4 w/Sems
10	532 19 69-77	Pan, Seat
21	532 17 18-52	Bolt, Shoulder 5/16-18
37	873 80 05-00	Nut, Lock 5/16-18 unc

KEY NO.	PART NO.	DESCRIPTION
40	532 19 76-61	Handle Slide Seat
41	532 19 82-00	Spring Latch Seat
43	874 76 06-12	Bolt 3/8-16 x 3/4
44	819 13 38-12	Washer 13/32 x 2-3/8 x 12 Ga.

NOTE: All component dimensions given in U.S. inches
1 inch = 25.4 mm

