

LTH126

Spare parts

Ersatzteile

Pièces détachées

Reserve onderdelen

Repuestos

Reservdelar

ILLUSTRATED PARTS LIST

MODEL NO. 96041015000
CUSTOMER CATALOG NO. LTH126
PRODUCT NO. 960 41 01-50

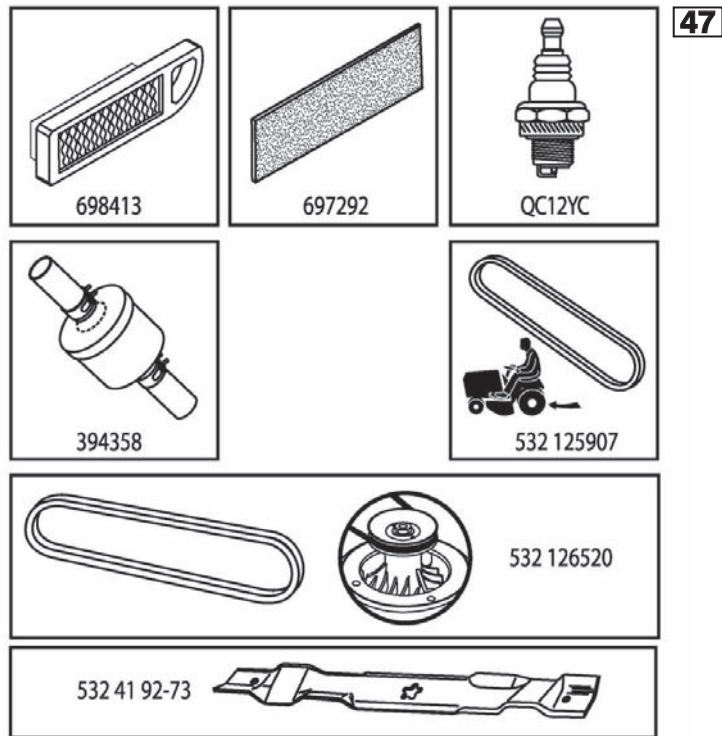

424372

TRACTOR - - MODEL NO. LTH126 (96041015000), PRODUCT NO. 960 41 01-50
DECALS 27

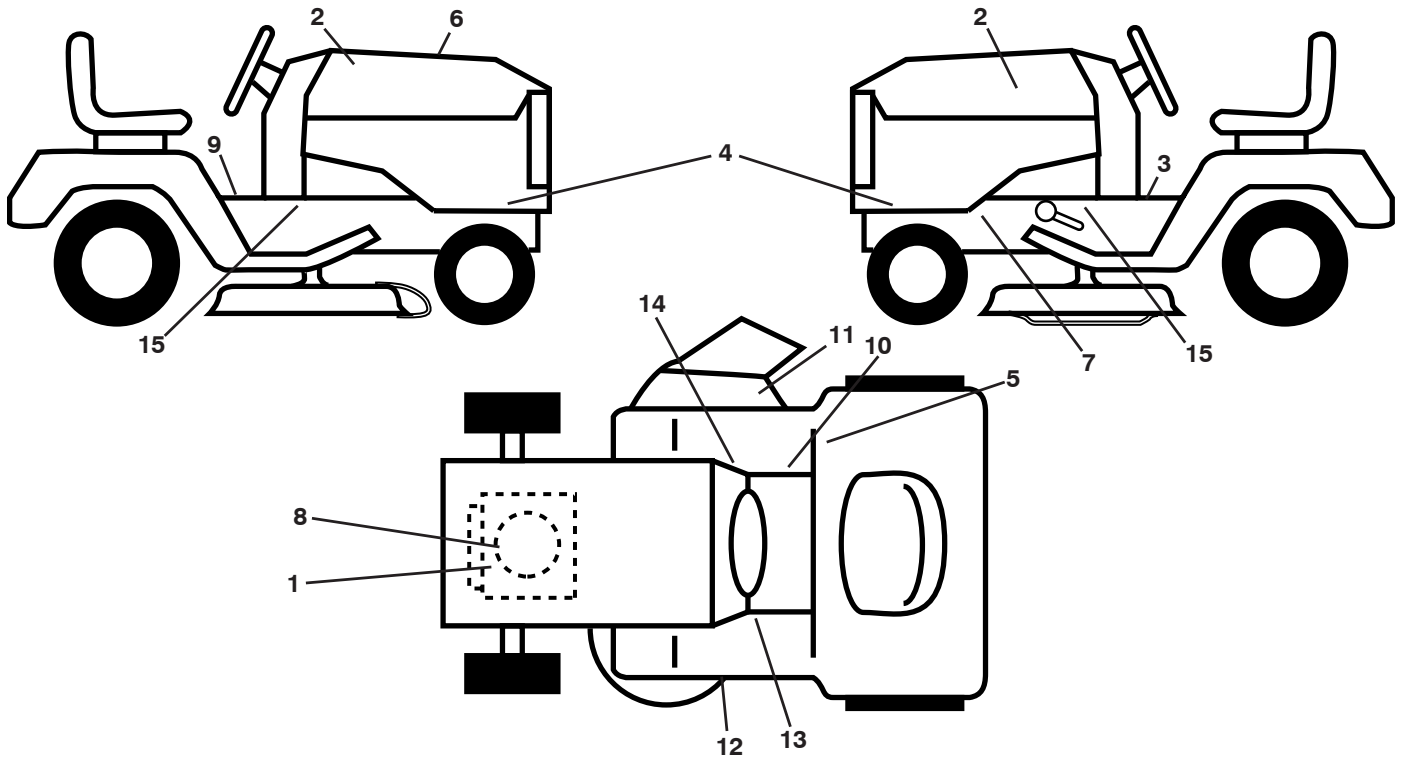

KEY NO.	PART NO.	DESCRIPTION
1	532 19 68-41	Decal, Warning Engine
2	532 42 91-96	Decal, Hood Logo
3	532 40 03-89	Decal, Warning Symbols
4	532 42 56-72	Decal, Hood Panel Side
5	532 18 04-32	Decal, Fender 100 DB/CE
6	532 42 43-72	Decal, Replacement
7	532 15 97-36	Decal, Chassis Hot Muffler
8	532 41 79-26	Decal, Engine
9	532 14 50-05	Decal, Battery Dnge/Poi
10	532 17 83-02	Decal, Oper. Cruise

KEY NO.	PART NO.	DESCRIPTION
11	532 42 51-12	Decal, Warning Deflect/Cutfinger
12	532 42 15-43	Decal, Mower V-Belt Schematic
13	532 15 97-37	Decal, Brake/Clutch
14	532 14 08-37	Decal, Saddle Brake Parking
15	532 40 11-46	Decal, Warning Service/Fire
--	532 16 69-60	Decal, Bypass
--	532 41 08-05	Pad, Footrest, LH
--	532 41 08-06	Pad, Footrest, RH
--	532 16 25-98	Decal, Drawbar Load Limit
--	532 43 19-98	Manual, Operator's (Euro)

WHEELS AND TIRES

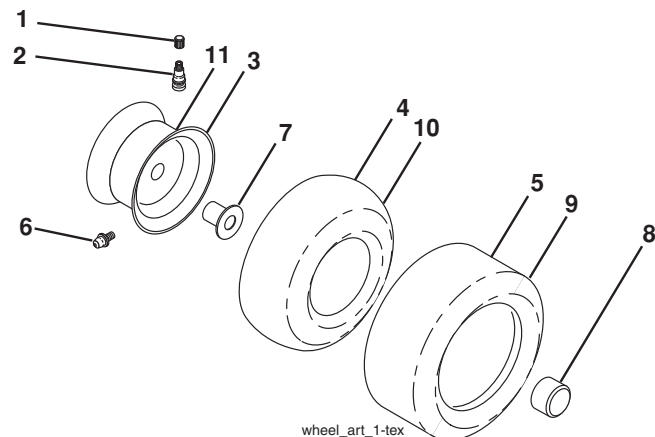

KEY NO.	PART NO.	DESCRIPTION
1	532 05 91-92	Cap Valve Tire
2	532 06 51-39	Stem Valve
3	532 42 52-61	Rim Asm 6" x 3.25 Front
4	532 42 16-52	Tube Front (Service Item Only)
5	532 12 34-10	Tire Front 13 x 5.0-6
6	532 12 49-57	Fitting Grease (Front Wheel Only)
7	532 12 49-59	Bearing Flange (Front Wheel Only)
8	532 17 50-39	Cap Axle Blk 1 50 x 1 00
9	532 10 62-30	Tire Rear 16 x 6 - 5
10	532 12 49-26	Tube Rear (Service Item Only)
11	532 42 52-62	Rim Asm 8" x 5.375 Rear
--	532 14 43-34	Sealant, Tire (10 oz. Tube)

NOTE: All component dimensions given in U.S. inches
 1 inch = 25.4 mm

TRACTOR - - MODEL NO. LTH126 (96041015000), PRODUCT NO. 960 41 01-50

SCHEMATIC **38**

SCH12

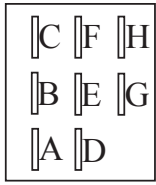
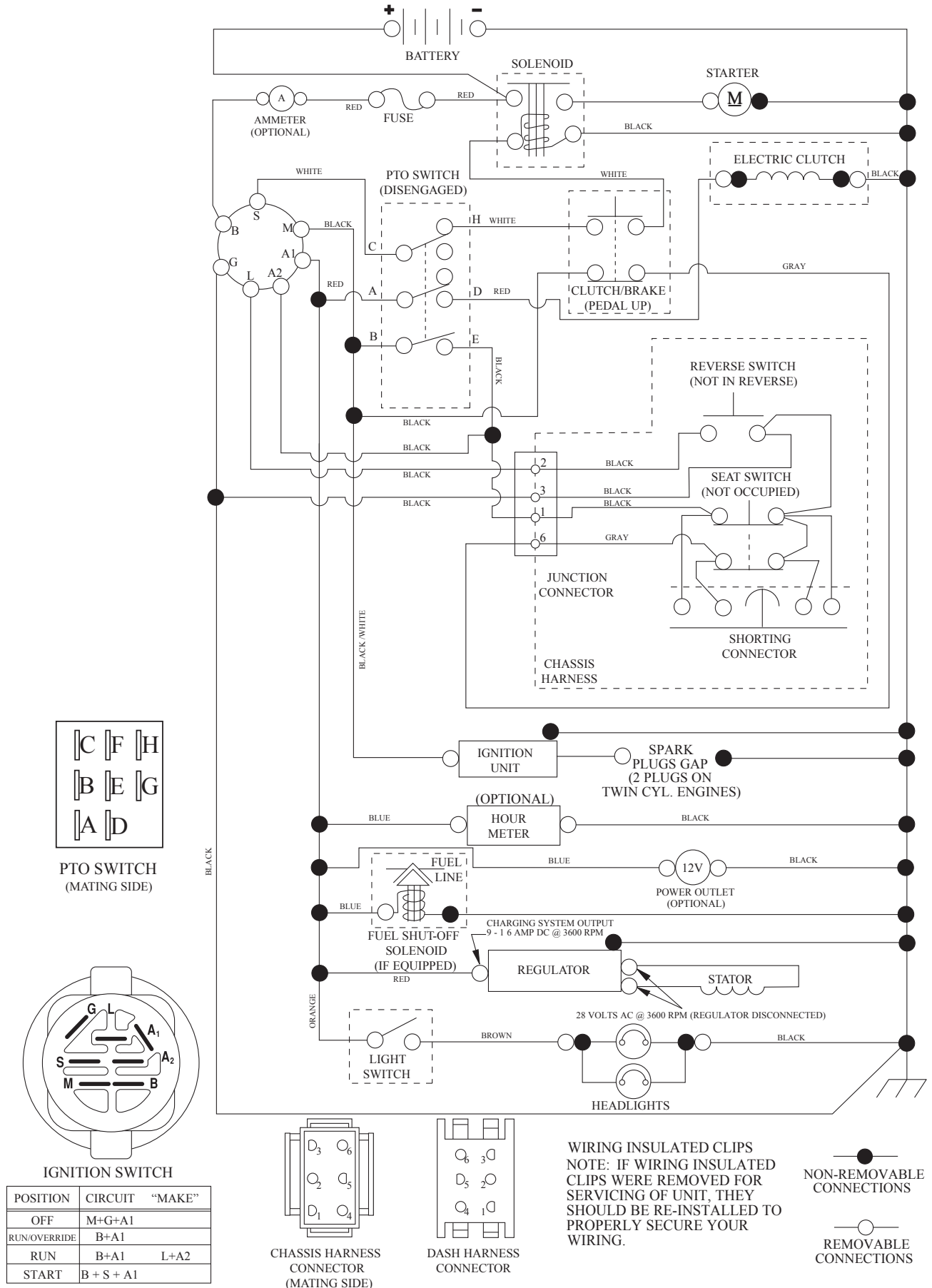

PTO SWITCH (MATING SIDE)

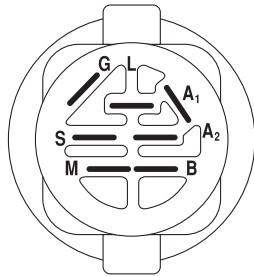

IGNITION SWITCH

POSITION	CIRCUIT	"MAKE"
OFF	M+G+A1	
RUN/OVERRIDE	B+A1	
RUN	B+A1	L+A2
START	B + S + A1	

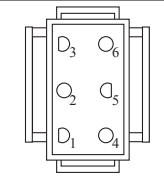

CHASSIS HARNESS CONNECTOR (MATING SIDE)

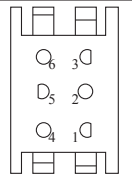

DASH HARNESS CONNECTOR

TRACTOR - - MODEL NO. LTH126 (96041015000), PRODUCT NO. 960 41 01-50
ELECTRICAL **32**

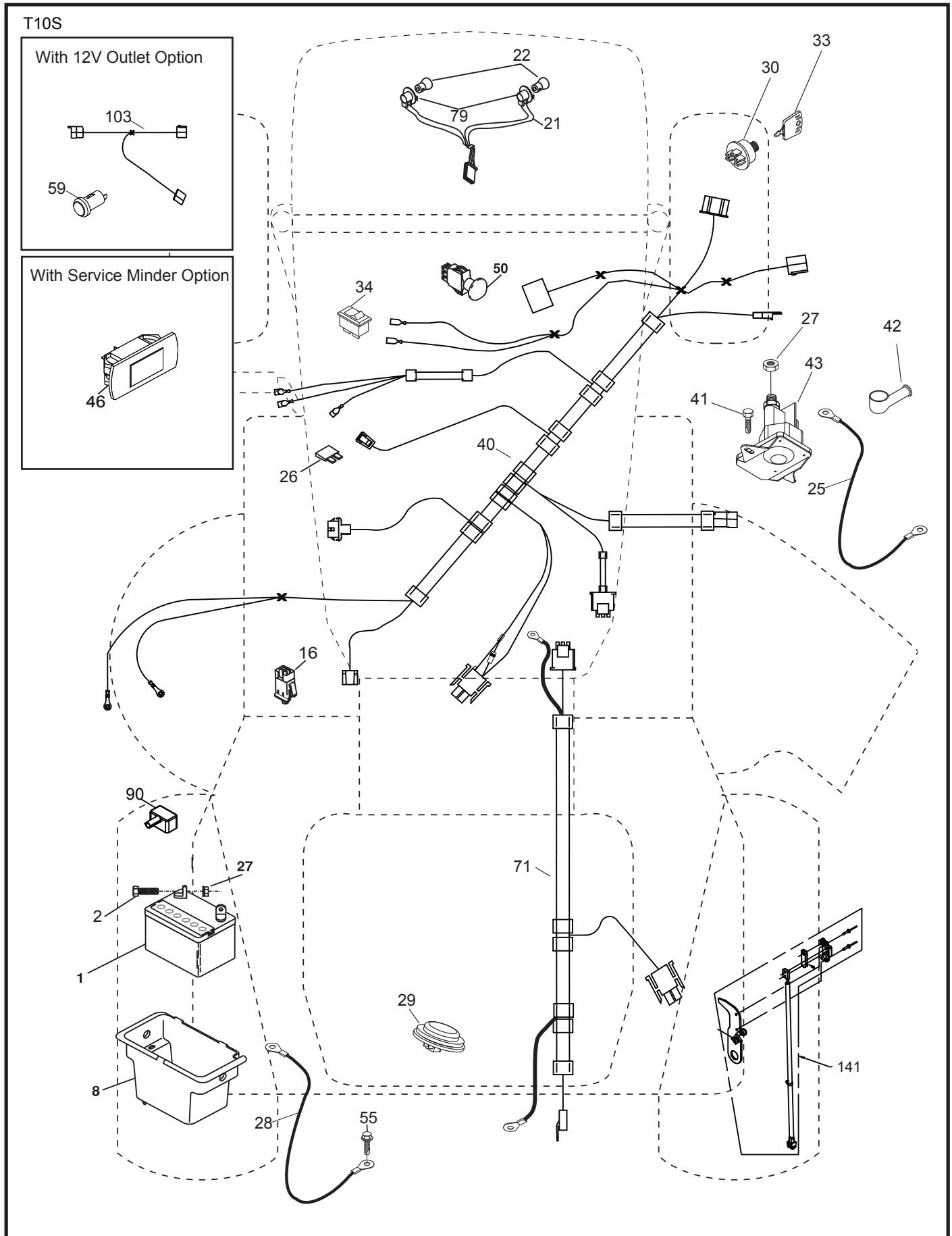

TRACTOR - - MODEL NO. LTH126 (96041015000), PRODUCT NO. 960 41 01-50
ELECTRICAL 32

KEY NO.	PART NO.	DESCRIPTION
1	532 14 49-24	Battery
2	874 76 04-12	Bolt Hex Head 1/4-20 x 3/4
8	532 19 32-28	Box Battery
16	532 17 61-38	Switch Interlock Push-In
21	532 40 02-52	Harness Socket Light w/4152J
22	532 00 41-52	Bulb Light
25	532 41 28-94	Cable Starter
26	532 17 51-58	Fuse
27	873 51 04-00	Nut Keps Hex 1/4-20 unc
28	532 19 88-85	Cable, Ground
29	532 40 15-45	Switch, Seat
30	532 19 33-50	Switch, Ign
33	532 41 19-35	Key/Chain
34	532 11 07-12	Switch Light/Reset
40	532 40 11-04	Harness Ign. Dash
41	817 72 04-08	Screw Thd Cut 1/4-20 x 1/2
42	532 13 15-63	Cover, Terminal
43	532 19 25-07	Solenoid
46	532 40 17-63	Gauge Hourmeter
50	532 17 46-51	Switch PTO
55	817 06 05-12	Screw Thdrol 5/16-18 x 3/4
71	532 40 04-49	Harness Chassis
79	532 17 52-42	Socket Asm Bulb Twistlock
90	532 40 07-25	Cover, Terminal Battery
141	532 41 69-77	Kit T2 ROS

NOTE: All component dimensions given in U.S. inches
1 inch = 25.4 mm

**TRACTOR - - MODEL NO. LTH126 (96041015000), PRODUCT NO. 960 41 01-50
CHASSIS AND ENCLOSURES 39**

KEY NO.	PART NO.	DESCRIPTION	KEY NO.	PART NO.	DESCRIPTION
3	532 40 50-12	Logo	204	532 41 11-16	Vent Top Hood
5	532 40 75-94	Dash	205	532 41 10-76	Skirt Side RH
14	532 44 12-67	Hood	206	532 41 10-77	Skirt Side LH
15	532 41 10-79	Lens LH	213	874 76 05-12	Bolt 5/16-18 x 3/4
18	532 42 69-63	Grille	214	532 19 91-45	Clip Retainer
25	532 41 10-78	Lens RH	217	532 40 91-67	Rod Pivot Hood
34	532 19 61-25	Plate Engine	218	532 19 63-95	X-Piece Hood Stop
36	817 06 05-12	Screw 5/16-18 x 3/4	228	532 19 51-61	Stud Fastener
37	532 44 12-66	Fender	234	532 40 47-42	Bumper Hood
52	873 68 05-00	Nut Crown Lock 5/16	235	532 40 61-29	Spacer Fender
58	532 41 22-80	Drawbar, Upper	236	873 93 05-00	Nut Lock 5/16-18 unc
68	817 49 05-08	Screw THDROL 5/16-18 x 1/2	238	532 41 11-19	Trim
130	532 41 63-58	Screw #10 x .750 BOS Thread	239	532 40 48-83	Clip Tinnerman
137	532 40 75-90	Bumper Dash	282	532 41 41-10	Clip Retainer Console
150	532 40 66-62	Air Duct	283	532 41 63-16	Console Deck Lift
151	532 40 78-07	Bracket Pivot	284	532 41 78-87	Console Shift
152	532 19 95-35	Shield Browning	285	532 41 63-15	Console Insert RH
162	532 14 24-32	Screw	286	532 41 63-17	Console Insert LH
175	532 19 94-72	Crossmember	287	817 60 04-06	Screw Hex Washhead 1/4-20 x 3/8
176	532 40 07-76	Screw 10-24 x 5/8	297	532 40 66-65	Insert Reflective LH
177	532 19 52-28	Bushing Steering	303	532 42 51-51	Shield Chassis LH
180	532 41 46-85	Chassis	304	532 42 51-52	Shield Chassis RH
182	532 40 71-76	Dash Lower	307	532 42 45-70	Shield Upper Pedal
183	874 78 05-20	Bolt 5/16-18 unc x 1-1/4	312	532 42 09-60	Shield Drawbar
189	817 00 05-12	Screw 5/16-18 x 3/4			
191	532 41 65-00	Insert Reflective RH			
194	873 90 05-00	Nut Lock Hex Flange 5/16-18			
199	532 41 34-85	Plate Deck Lift			
202	532 41 10-75	Vent Side Hood RH			
203	532 41 10-74	Vent Side Hood LH			

NOTE: All component dimensions given in U.S. inches
1 inch = 25.4 mm

TRACTOR - - MODEL NO. LTH126 (96041015000), PRODUCT NO. 960 41 01-50
DRIVE **40**

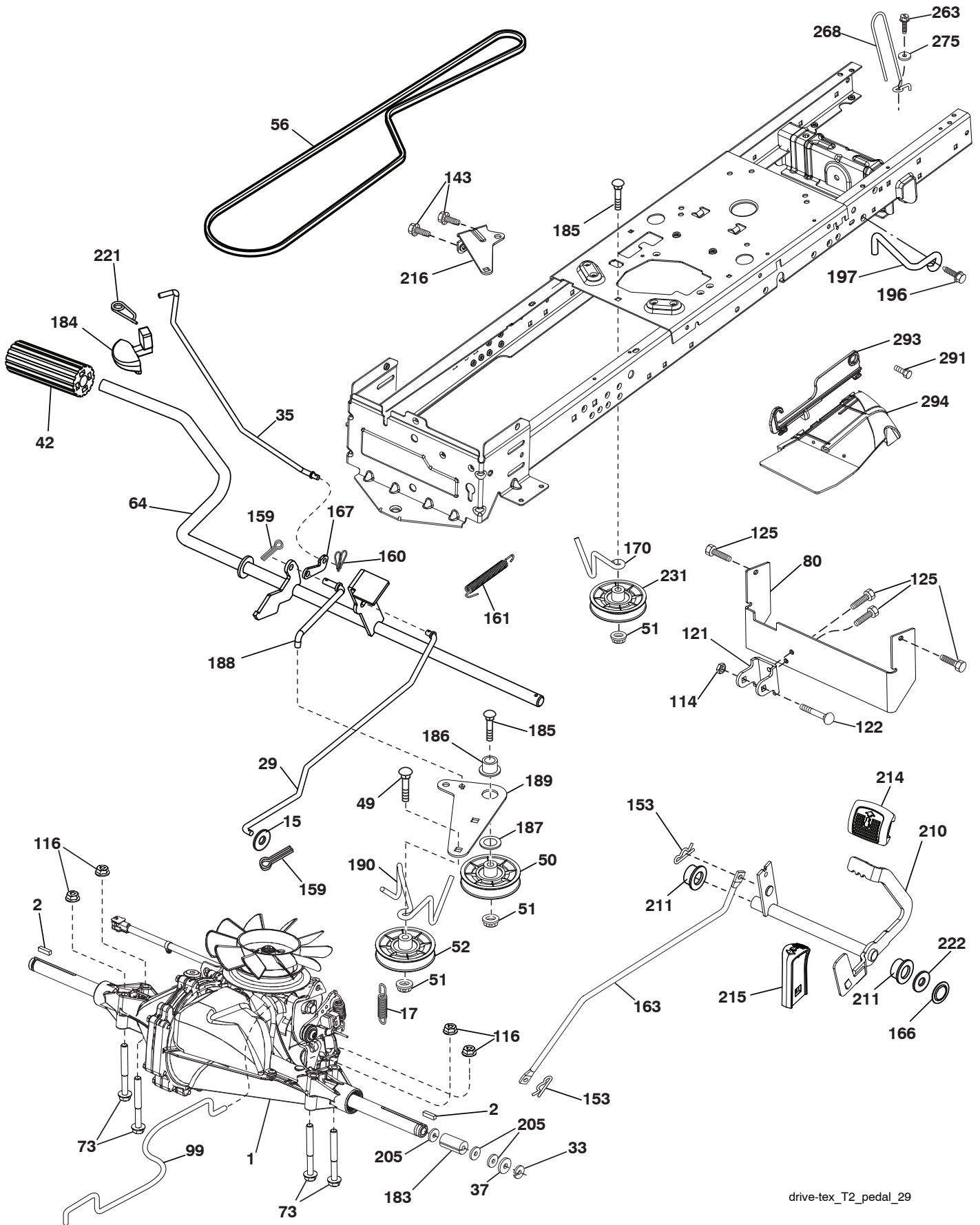

drive-tex_T2_pedal_29

TRACTOR - - MODEL NO. LTH126 (96041015000), PRODUCT NO. 960 41 01-50
DRIVE 40

KEY NO.	PART NO.	DESCRIPTION	KEY NO.	PART NO.	DESCRIPTION
1	----	Transaxle, Hydro Gear T2-BABC-1X2B-1GX1	167	532 40 52-57	Latch Brake Parking
2	532 12 35-83	Key	170	532 41 34-30	Keeper Belt Centerspan
15	819 13 13-16	Washer 13/32 x 13/16 x 16 Ga.	183	532 15 69-72	Spacer Axle
17	532 19 72-96	Spring, Brake	184	532 40 97-47	Handle Parking Brake
29	532 42 32-39	Rod, Brake	185	872 11 06-22	Bolt
33	812 00 00-01	Ring E	186	532 19 43-21	Spacer Retainer
35	532 40 10-31	Rod, Brake, Park	187	819 13 32-10	Washer
37	532 12 17-49	Washer 25/32 x 1-1/4 x 16 Ga.	188	532 19 43-23	Link Clutch Ground Drive
42	532 12 48-72	Cover, Foot Pedal	189	532 19 43-17	Bellcrank Ground Drive
49	872 11 06-14	Bolt	190	532 19 43-18	Keeper Bellcrank Ground Drive
50	532 19 43-27	Pulley Idler Flat	196	817 00 06-16	Screw 3/8-16 x 1
51	873 90 06-00	Lock Nut 3/8-16	197	532 19 58-04	Link Clutch Anti-Rotation
52	532 19 43-26	Idler V-Groove 910" Offset	205	532 12 17-48	Washer 25/32 x 1-5/8 x 16 Ga.
56	532 12 59-07	V-Belt, Drive	210	532 40 09-80	Rockr Asm. Pdeal Control
64	532 19 78-65	Shaft Asm. Pedal Brake Control	211	532 12 01-83	Bearing Nylon
73	874 49 05-44	Bolt 5/16-18 Gr. 5	214	532 42 12-63	Pad Pedal Forward
80	532 40 83-93	Strap Torque	215	532 40 17-23	Pad Pedal Reverse
99	532 40 84-18	Rod Asm Bypass Spring	216	532 19 61-31	Bracket Pulley Idler
114	873 80 05-00	Nut Lock 5/16-18 unc	221	532 40 31-87	Retainer Spring Clip Handle
116	873 90 05-00	Nut Lock Hex Flange 5/16-18	222	879 21 20-10	Washer 21/32 x 1-1/4 10 Ga.
121	532 17 56-11	Bracket Strap Torque	231	532 40 72-87	Idler V-Groove 1.688
122	872 01 05-20	Bolt 5/16-18 x 2.50	263	817 00 06-12	Screw 3/8-16 x 3/4
125	817 00 05-12	Screw 5/16-18 x 3/4	268	532 18 24-02	Guard Muffler
143	817 49 05-08	Screw Thdrol 5/16-18 x 1/2	275	819 13 16-14	Washer 13/32 x 1 x 14 Ga.
153	532 12 47-88	Retainer Spring	291	532 17 01-65	Bolt Shoulder 5/16-18
159	876 02 04-12	Pin Cotter 1/8 x 3/4	293	532 42 25-48	Hinge RH
160	532 16 94-84	Retainer Clip	294	532 43 03-03	Guard Asm. RH
161	532 10 57-09	Spring, Return, Clutch			
163	532 41 33-22	Rod Pedal Control			
166	532 42 83-05	Nut Push .625			

NOTE: All component dimensions given in U.S. inches
1 inch = 25.4 mm

TRACTOR - - MODEL NO. LTH126 (96041015000), PRODUCT NO. 960 41 01-50
ENGINE 24

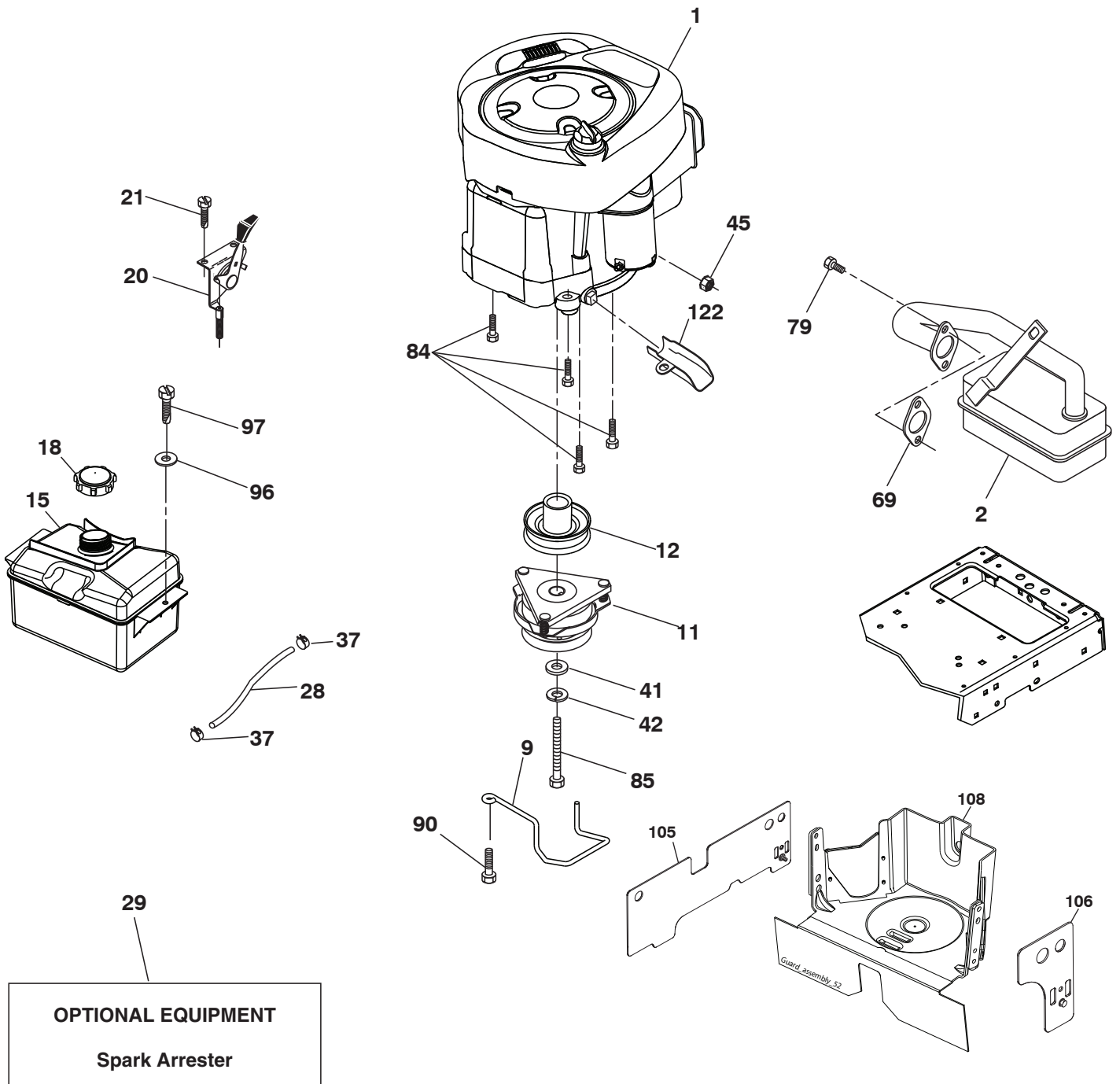

engine-tex_BS_32

**TRACTOR - - MODEL NO. LTH126 (96041015000), PRODUCT NO. 960 41 01-50
ENGINE 24**

KEY NO.	PART NO.	DESCRIPTION
1	-----	Engine Briggs Model No. 219807-1376-B1
2	532 17 97-58	Muffler
9	532 19 43-19	Keeper Belt Engine
11	532 18 05-05	Clutch Ogura
12	532 19 43-38	Pulley Engine
15	532 40 75-45	Tank Fuel
18	532 43 02-20	Cap Asm Fuel
20	532 18 38-97	Control Throttle
21	532 41 63-58	Screw #10 x 0.750 BOS Thread
28	532 13 70-40	Fuel Line
29	532 13 71-80	Spark Arrester Kit
37	532 12 34-87	Clamp Hose
41	532 12 61-97	Washer 1-1/2 OD x 15/32 ID x .250
42	810 04 07-00	Washer Lock 7/16
45	873 51 04-00	Nut Keps Hex 1/4-20 unc
69	532 16 52-91	Gasket
79	532 19 23-34	Screw 5/16-18 x 3/4
84	817 06 06-20	Screw 3/8-16 x 1/4
85	532 17 39-37	Bolt Hex 7/16-20 x 4 Gr. 5-1.5 THR
90	817 00 06-16	Screw 3/8-16 x 1
96	819 09 14-16	Washer 9/32 x 7/8 x 16 Ga.
97	817 67 04-12	Screw 1/4-20 x 3/4
105	532 44 06-74	Shield SRD LH
106	532 44 06-79	Shield Side RH
108	532 43 16-89	Cover Pulley
122	532 42 19-22	Extension Drain Oil

NOTE: All component dimensions given in U.S. inches
1 inch = 25.4 mm

Engine Power Rating Information

The gross power rating for individual gas engine models is labeled in accordance with SAE (Society of Automotive Engineers) code J1940 (Small Engine Power & Torque Rating Procedure), and rating performance has been obtained and corrected in accordance with SAE J1995 (Revision 2002-05). Torque values are derived at 3060 RPM; horsepower values are derived at 3600 RPM. Actual gross engine power will be lower and is affected by, among other things, ambient operating conditions and engine-to-engine variability. Given both the wide array of products on which engines are placed and the variety of environmental issues applicable to operating the equipment, the gas engine will not develop the rated gross power when used in a given piece of power equipment (actual "on-site" or net power). This difference is due to a variety of factors including, but not limited to, accessories (air cleaner, exhaust, charging, cooling, carburetor, fuel pump, etc.), application limitations, ambient operating conditions (temperature, humidity, altitude), and engine-to-engine variability. Due to manufacturing and capacity limitations, Briggs & Stratton may substitute an engine of higher rated power for this Series engine.

TRACTOR - - MODEL NO. LTH126 (96041015000), PRODUCT NO. 960 41 01-50
STEERING ASSEMBLY **41**

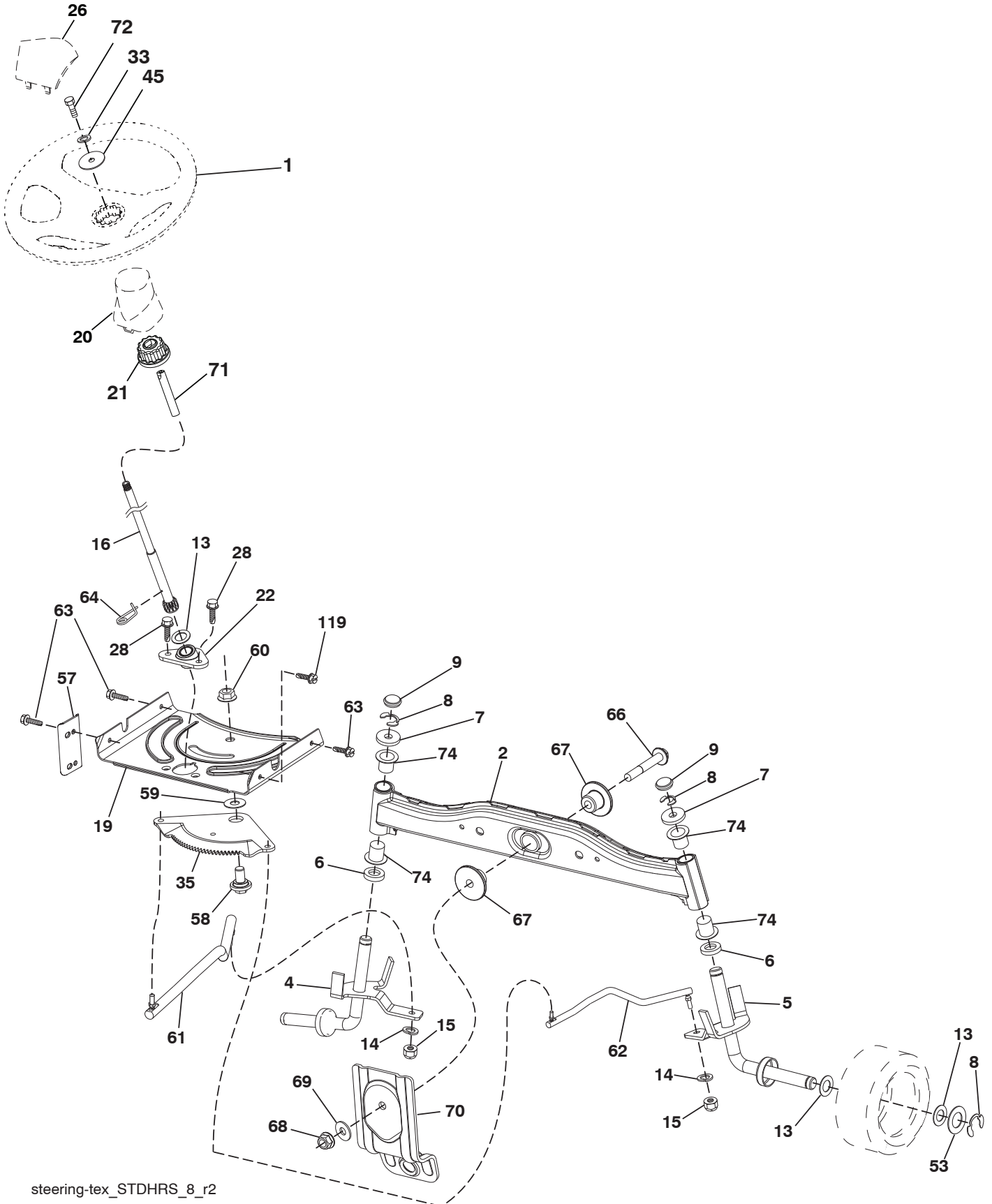

steering-tex_STDHRS_8_r2

TRACTOR - - MODEL NO. LTH126 (96041015000), PRODUCT NO. 960 41 01-50
STEERING ASSEMBLY 41

KEY NO.	PART NO.	DESCRIPTION
1	532 41 64-80	Wheel, Steering
2	532 41 81-68	Axle Asm., Front
4	532 41 68-45	Spindle Asm., LH
5	532 41 68-46	Spindle Asm., RH
6	532 12 49-31	Washer Thrust
7	532 12 17-48	Washer 25/32 x 1-5/8 x 16 Ga.
8	812 00 00-29	Ring, Klip #T5304-75
9	532 12 12-32	Cap, Spindle
13	532 12 17-49	Washer 25/32 x 1-1/4 x 16 Ga.
14	810 04 06-00	Washer, Lock Hvy Hlcl Spr 3/8
15	873 54 06-00	Nut, Crown Lock 3/8-24 unf
16	532 42 93-73	Shaft Steering
19	532 19 47-29	Plate Steering
20	532 41 11-39	Boot, Steering
21	532 18 67-37	Adapter, Wheel Steering
22	532 42 05-37	Strg. Supt. Lower
26	532 41 59-87	Insert, Wheel Steering
28	817 00 06-12	Screw 3/8-16 x 3/4
33	810 04 05-00	Washer Lock 5/16
35	532 19 47-32	Gear, Sector Plate
45	819 11 38-12	Washer 11/32 x 3/8 x 12 Ga.
53	532 18 89-67	Washer Hardened .793 x 1.637 x .060
57	532 40 74-65	Bracket Upstop
58	532 19 47-47	Bolt Shoulder Sector Pivot CFM
59	532 19 47-48	Washer Thrust Sector Steering
60	873 97 10-00	Nut Flange Lock 5/8-11
61	532 19 47-40	Draglink, LH
62	532 19 47-41	Draglink, RH
63	817 00 05-12	Screw 5/16-18 x 3/4
64	532 19 98-49	Retainer Clip Spring Steering
66	871 02 07-48	Bolt Hex Fghd 7/16-14 x 3 Serr
67	532 19 47-37	Bushing PM Front Axle
68	873 90 07-00	Nut Lock Flange 7/16-14 Gr. 5
69	532 19 91-62	Washer 1.5 x .505 x .118
70	532 41 70-65	Bracket Deck Susp. Front
71	532 19 07-52	Shaft Extension Steering
72	532 42 89-82	Bolt 5/16-18 x 4 w/patch
74	532 12 49-37	Bearing
119	532 17 01-65	Bolt Shoulder 5/16-18

NOTE: All component dimensions given in U.S. inches
1 inch = 25.4 mm

TRACTOR - - MODEL NO. LTH126 (96041015000), PRODUCT NO. 960 41 01-50
MOWER DECK 44

KEY NO.	PART NO.	DESCRIPTION
1	532 41 92-72	Deck Weldment 30"Srd
2	532 19 51-61	Stud Fastner w/D'anti-Rotatio
3	873 90 05-00	Nut Lock Hex Flange 5/16 - 18
4	532 41 76-45	Bracket Clutch Cable
5	817 00 05-10	Bolt 5/16-18
6	532 41 88-63	Arm Susp Mower Rear Srd
8	532 42 02-52	Arm Idler 30"Srd
9	532 19 90-92	Spacer Retainer
10	817 00 06-16	Screw 3/8 - 16 X 1 Smgml Tap/R Blk
11	532 13 77-29	Screw Thd Roll 1/4 - 20 X 5/8
13	872 11 06-12	Bolt Carr Sh 3/8 - 16 X 1 - 1/2 Gr5
14	532 15 60-85	Keeper Belt Idler
15	532 14 67-63	Pulley Idler V-Groove Dim 4.25
16	873 90 06-00	Nut Lock FIG 3/8 - 16 unc
17	532 40 02-34	Nut Flange Lock Top
18	532 18 76-90	Washer Spacer Mandrel
19	532 11 04-85	Bearing Ball Mandrel
20	532 17 39-84	Screw Thd Roll Dod Pt Hex
22	532 19 31-98	Pulley Idler Flat Unplated
23	817 49 06-28	Screw Thdrol 3/8 - 16 X 1-3/4
24	819 13 20-12	Washer 13/32 X 1 - 1/4 X 12 Ga
25	532 42 02-53	Keeper Belt 30"Srd
26	532 42 02-55	Cover Mandrel Mwr 30"Black
27	532 41 92-71	V-Belt Drive
28	532 41 73-44	Shield Asm Deflect Mwr 30s Blk
29	532 42 08-95	Pin Hinge 30
30	532 19 70-26	Spring Torsion Dfl 38/42/46 Gr
31	532 11 04-52	Nut Push Phos & Oil
32	532 19 72-51	Spring Return Deck 38/46"
33	532 18 72-81	Housing Mandrel 4pt Service
34	532 19 28-72	Shaft Asm Mndrl N/Greaseable38
35	532 41 92-73	Blade Mower Hp/Mulch Srd
36	532 19 30-03	Bolt/Washer Asm 7/16 - 20 unf
38	532 19 65-39	Bolt Shoulder
39	532 10 53-04	Cap Sleeve
43	532 41 68-77	Pulley Mandrel 6 5 Pd 30"
76	532 41 55-98	Washout Port
78	532 42 25-66	Guard Deck SRD Arm Clutch
79	532 14 24-32	Screw Hex Wsh 1/4 x 1/2 unc
80	532 42 30-62	Palnut 1/4"
81	532 42 53-67	Shield Asm. Suspension
83	532 43 03-15	Guard LH
- -	532 19 28-70	Mandrel Assembly (Includes Housing, Shaft Assembly, And Bearing Only - Pulley/Nut/Washer And Blade Bolt/Washers Not Included)
- -	532 43 19-97	Replacement Mower Complete

NOTE: All component dimensions given in U.S. inches
1 inch = 25.4 mm

TRACTOR - - MODEL NO. LTH126 (96041015000), PRODUCT NO. 960 41 01-50
SEAT ASSEMBLY 42

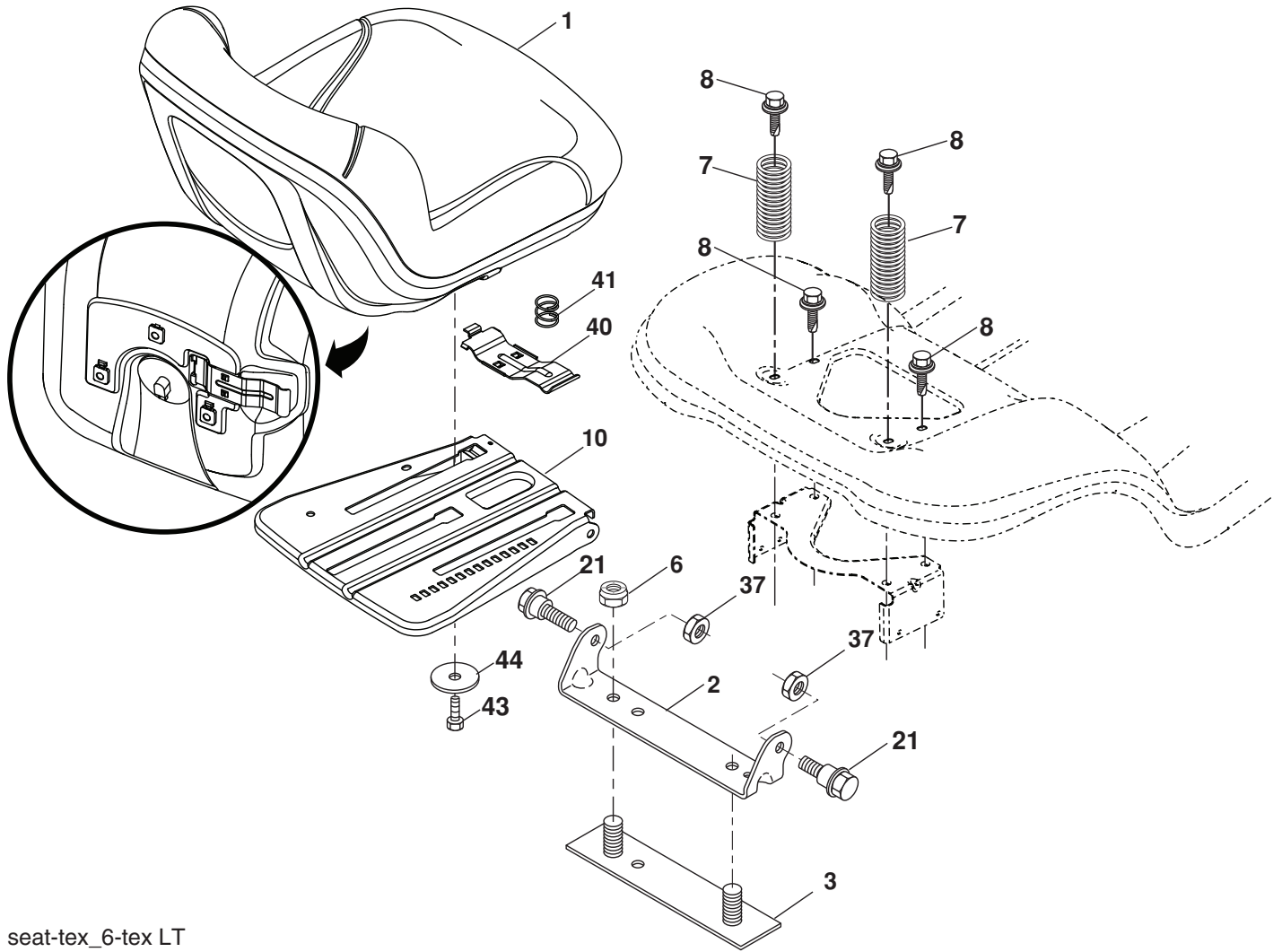

seat-tex_6-tex LT

KEY NO.	PART NO.	DESCRIPTION
1	532 42 40-67	Seat
2	532 18 01-66	Bracket Pivot Fender
3	532 14 06-75	Strap, Asm Fender
6	873 80 06-00	Nut, Lock w/Ins. 3/8-16 unc
7	532 12 41-81	Spring, Seat Cprsn
8	532 17 18-77	Bolt 5/16-18 unc x 3/4 w/Sems
10	532 19 69-77	Pan, Seat
21	532 17 18-52	Bolt, Shoulder 5/16-18

KEY NO.	PART NO.	DESCRIPTION
37	873 80 05-00	Nut, Lock 5/16-18 unc
40	532 19 76-61	Handle Slide Seat
41	532 19 82-00	Spring Latch Seat
43	874 76 06-12	Bolt Fin Hex 3/8-16 unc x 3/4
44	819 13 38-12	Washer 13/32 x 2-3/8 x 12 Ga.

NOTE: All component dimensions given in U.S. inches
 1 inch = 25.4 mm

TRACTOR - - MODEL NO. LTH126 (96041015000), PRODUCT NO. 960 41 01-50
MOWER LIFT 45

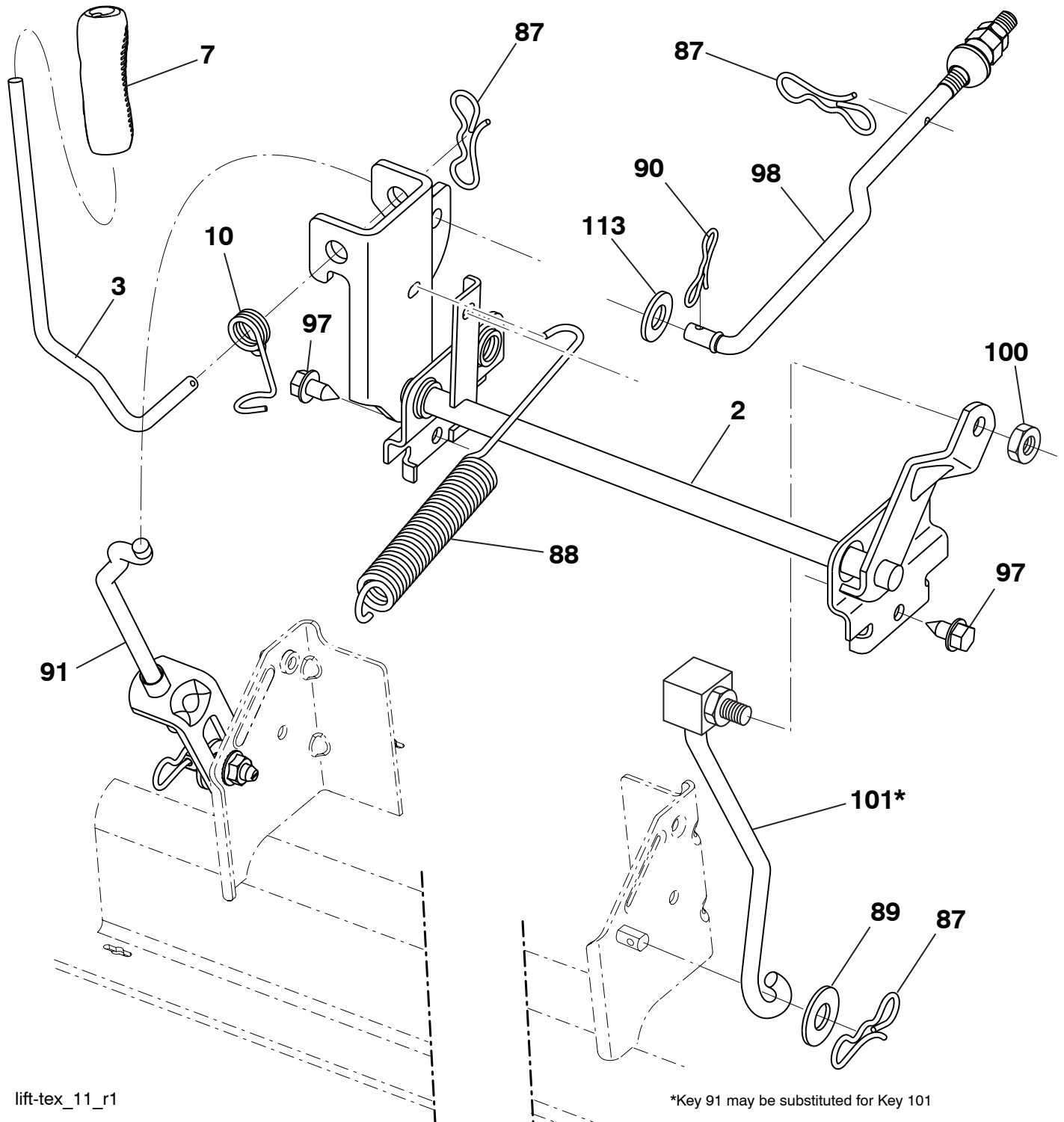

lift-tex_11_r1

*Key 91 may be substituted for Key 101

KEY NO.	PART NO.	DESCRIPTION
2	532 42 20-27	Shaft Asm., Lift
3	532 19 52-31	Lever Asm., Lift RH
7	532 41 15-55	Grip, Lever
10	532 19 63-14	Spring Torsion
87	532 19 42-09	Pin Cotter 7/16 Bow Tie Lock
88	532 41 07-10	Spring Lift Assist
89	819 19 19-12	Washer Clear Zinc
90	532 19 42-08	Pin Cotter 5/16 Bow Tie Lock

KEY NO.	PART NO.	DESCRIPTION
91	532 19 51-81	Link Asm Lift LH Rear
97	817 00 06-12	Screw Hex Wsh. THDR 3/8-16 x 3/4
98	532 19 52-64	Link Lift Susp. Front Mower
100	873 93 06-00	Nut Centerlock 3/8-16 unc
101	532 40 70-03	Link Asm Lift FXD

NOTE: All component dimensions given in U.S. inches
 1 inch = 25.4 mm

