

# LTH126

**Spare parts**

**Ersatzteile**

**Pièces détachées**

**Reserve onderdelen**

**Repuestos**

**Reservdelar**

# ILLUSTRATED PARTS LIST

MODEL NO. 96041019900

CUSTOMER CATALOG NO. LTH126

PRODUCT NO. 960 41 01-99

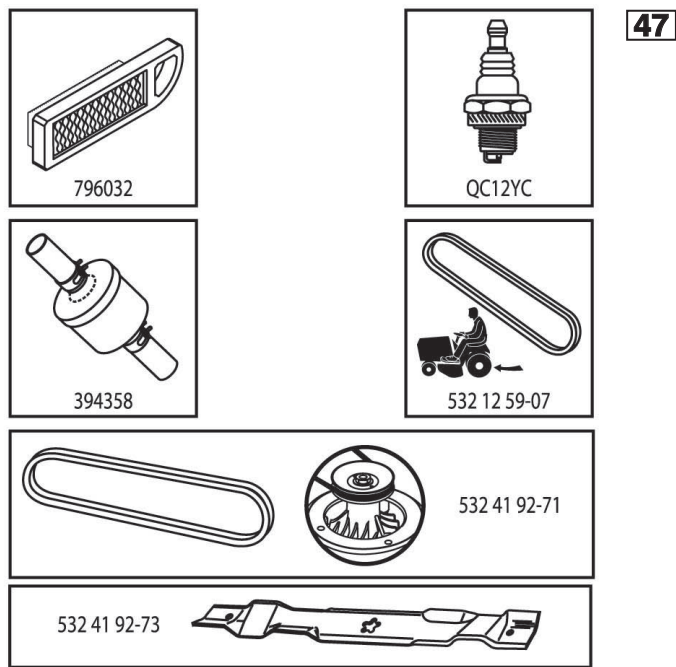

442547

**TRACTOR - - MODEL NO. LTH126 (96041019900), PRODUCT NO. 960 41 01-99**  
**DECALS 27**

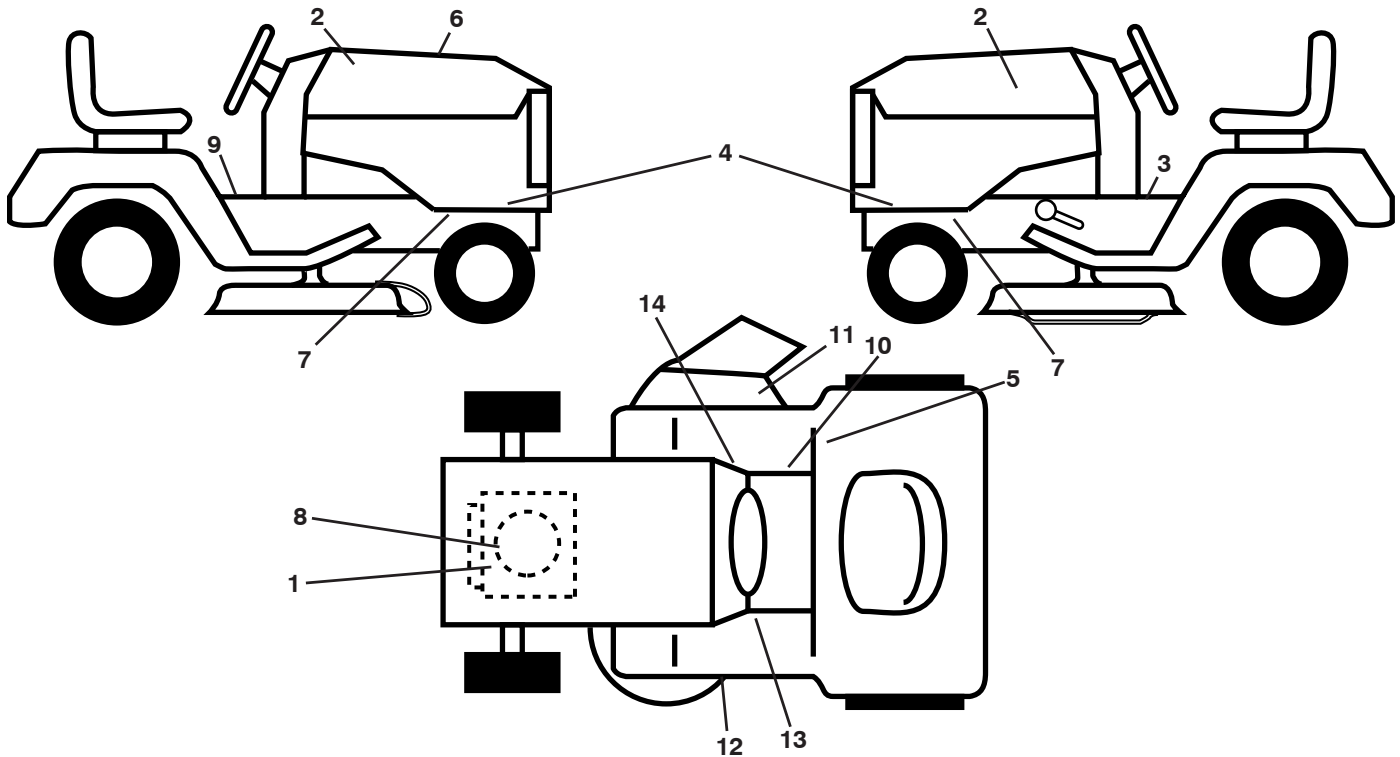

KEY NO.	PART NO.	DESCRIPTION
1	532 19 68-41	Decal, Warning Engine
2	581 62 73-01	Hood Emblem
3	532 40 03-89	Decal, Warning Symbols
4	532 42 56-72	Decal, Hood Panel Side
5	532 18 04-32	Decal, Fender 100 DB/CE
6	532 44 25-47	Decal, Replacement
7	532 15 97-36	Decal, Chassis Hot Muffler
8	532 43 74-10	Decal, Engine
9	532 14 50-05	Decal, Battery Dnge/Poi
10	532 17 83-02	Decal, Oper. Cruise
11	532 42 51-12	Decal, Warning Deflect/Cutfinger

KEY NO.	PART NO.	DESCRIPTION
12	532 42 15-43	Decal, Mower V-Belt Schematic
13	532 15 97-37	Decal, Brake/Clutch
14	532 14 08-37	Decal, Saddle Brake Parking
--	532 16 69-60	Decal, Bypass
--	532 41 08-05	Pad, Footrest, LH
--	532 41 08-06	Pad, Footrest, RH
--	532 16 25-98	Decal, Drawbar Load Limit
--	532 43 40-49	Manual, Operator's (Euro)
--	532 43 40-50	Manual, Operator's (Scand)
--	532 43 40-51	Manual, Operator's (EBlock)
--	532 43 40-52	Manual, Operator's (Baltic)

**WHEELS AND TIRES**

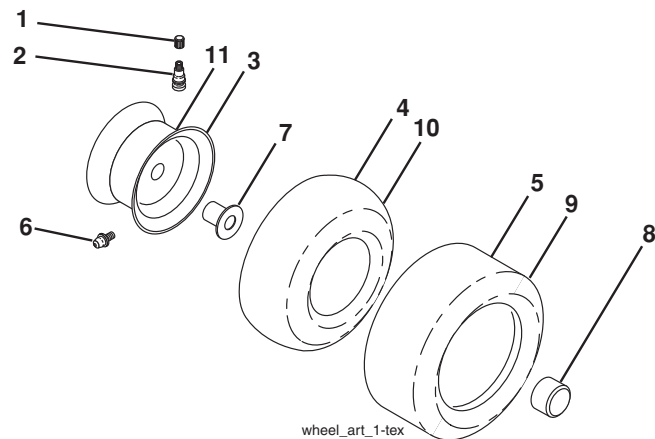

KEY NO.	PART NO.	DESCRIPTION
1	532 05 91-92	Cap Valve Tire
2	532 06 51-39	Stem Valve
3	532 42 52-61	Rim Asm 6" x 3.25 Front
4	532 42 16-52	Tube Front (Service Item Only)
5	532 12 34-10	Tire Front 13 x 5.0-6
6	532 12 49-57	Fitting Grease (Front Wheel Only)
7	532 12 49-59	Bearing Flange (Front Wheel Only)
8	532 17 50-39	Cap Axle Blk 1 50 x 1 00
9	532 10 62-30	Tire Rear 16 x 6 - 5
10	532 12 49-26	Tube Rear (Service Item Only)
11	532 42 52-62	Rim Asm 8" x 5.375 Rear
--	532 14 43-34	Sealant, Tire (10 oz. Tube)

**NOTE:** All component dimensions given in U.S. inches  
 1 inch = 25.4 mm

# TRACTOR - - MODEL NO. LTH126 (9604101990), PRODUCT NO. 960 41 01-99

## SCHEMATIC **38**

SCH12

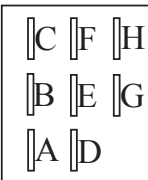
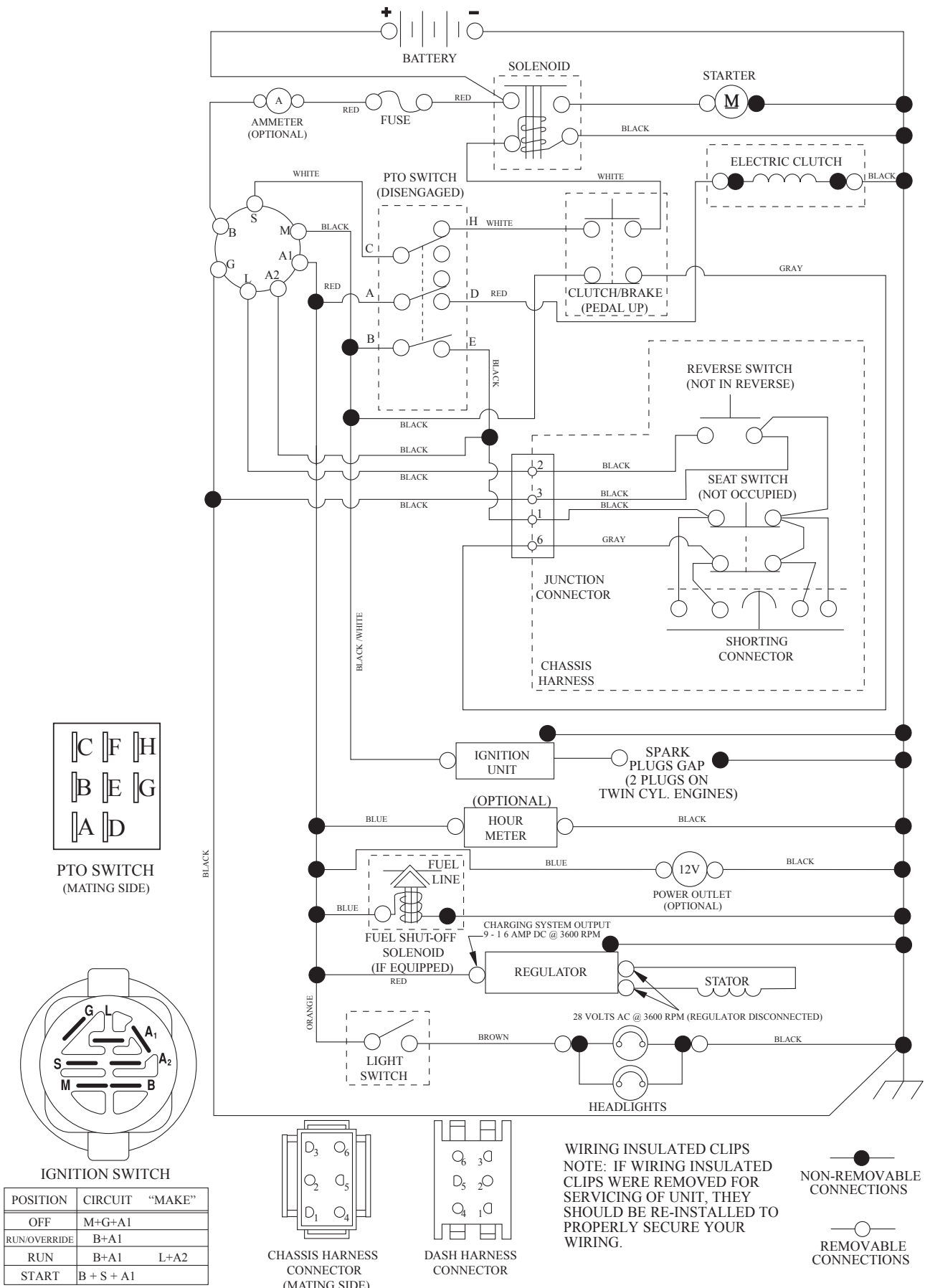

PTO SWITCH (MATING SIDE)

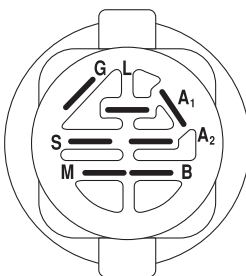

IGNITION SWITCH

POSITION	CIRCUIT	"MAKE"
OFF	M+G+A1	
RUN/OVERRIDE	B+A1	
RUN	B+A1	L+A2
START	B + S + A1	

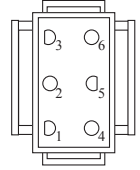

CHASSIS HARNESS CONNECTOR (MATING SIDE)

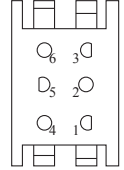

DASH HARNESS CONNECTOR

WIRING INSULATED CLIPS  
NOTE: IF WIRING INSULATED CLIPS WERE REMOVED FOR SERVICING OF UNIT, THEY SHOULD BE RE-INSTALLED TO PROPERLY SECURE YOUR WIRING.



NON-REMOVABLE CONNECTIONS



REMOVABLE CONNECTIONS



**TRACTOR - - MODEL NO. LTH126 (96041019900), PRODUCT NO. 960 41 01-99**  
**ELECTRICAL 32**

<b>KEY NO.</b>	<b>PART NO.</b>	<b>DESCRIPTION</b>
1	532 16 34-65	Battery
2	874 76 04-12	Bolt Hex Head 1/4-20 x 3/4
8	532 19 32-28	Box Battery
16	532 17 61-38	Switch Interlock Push-In
21	532 40 02-52	Harness Socket Light w/4152J
22	532 00 41-52	Bulb Light
25	532 41 28-94	Cable Starter
26	532 17 51-58	Fuse
27	873 51 04-00	Nut Keps Hex 1/4-20 unc
28	532 19 88-85	Cable, Ground
29	532 40 15-45	Switch, Seat
30	532 19 33-50	Switch, Ign
33	532 41 19-35	Key/Chain
34	532 11 07-12	Switch Light/Reset
40	532 40 11-04	Harness Ign. Dash
41	817 72 04-08	Screw Thd Cut 1/4-20 x 1/2
42	532 13 15-63	Cover, Terminal
43	532 19 25-07	Solenoid
46	532 40 17-63	Gauge Hourmeter
50	532 17 46-51	Switch PTO
55	817 06 05-12	Screw Thdrol 5/16-18 x 3/4
71	532 40 04-49	Harness Chassis
79	532 17 52-42	Socket Asm Bulb Twistlock
90	532 43 53-95	Cover, Terminal Battery
141	532 41 69-77	Kit T2 ROS

**NOTE:** All component dimensions given in U.S. inches  
1 inch = 25.4 mm

**TRACTOR - - MODEL NO. LTH126 (96041019900), PRODUCT NO. 960 41 01-99**  
**CHASSIS AND ENCLOSURES 39**

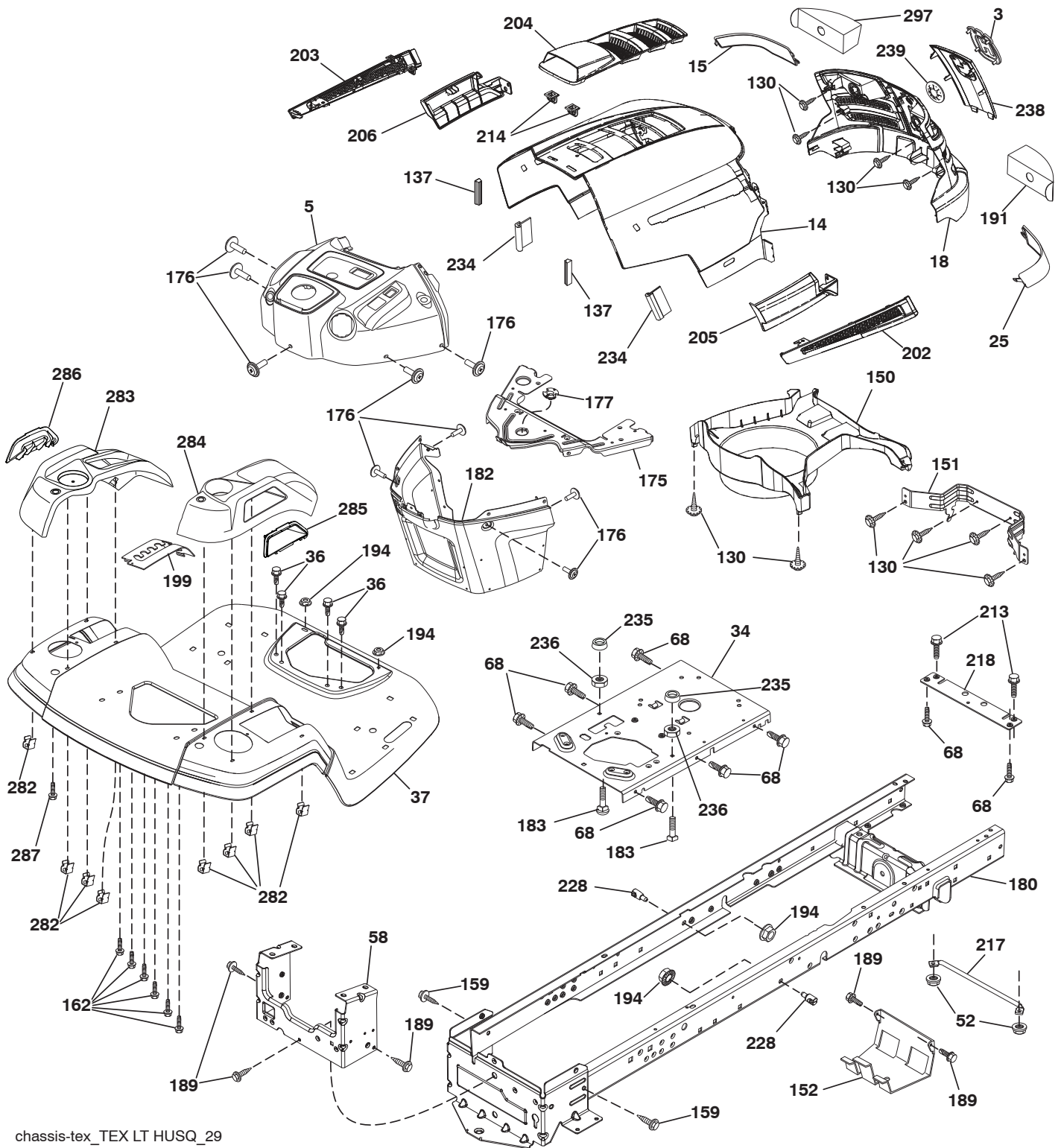

chassis-tex\_TEX LT HUSQ\_29

**TRACTOR - - MODEL NO. LTH126 (9604101990), PRODUCT NO. 960 41 01-99  
CHASSIS AND ENCLOSURES 39**

KEY NO.	PART NO.	DESCRIPTION	KEY NO.	PART NO.	DESCRIPTION
3	532 40 50-12	Logo	194	873 90 05-00	Nut Lock Hex Flange 5/16-18
5	532 40 75-94	Dash	199	532 41 34-85	Plate Deck Lift
14	532 44 12-67	Hood	202	532 41 17-85	Vent Side Hood RH
15	532 41 10-79	Lens LH	203	532 41 10-74	Vent Side Hood LH
18	532 42 69-63	Grille	204	532 41 11-16	Vent Top Hood
25	532 41 10-78	Lens RH	205	532 41 10-76	Skirt Side RH
34	532 19 61-25	Plate Engine	206	532 41 10-77	Skirt Side LH
36	817 06 05-12	Screw 5/16-18 x 3/4	213	874 76 05-12	Bolt 5/16-18 x 3/4
37	532 44 12-66	Fender	214	532 19 91-45	Clip Retainer
52	873 68 05-00	Nut Crown Lock 5/16	217	532 40 91-67	Rod Pivot Hood
58	532 41 22-80	Drawbar, Upper	218	532 19 63-95	X-Piece Hood Stop
68	817 49 05-08	Screw THDROL 5/16-18 x 1/2	228	532 19 51-61	Stud Fastener
130	532 41 63-58	Screw #10 x .750 BOS Thread	234	532 40 47-42	Bumper Hood
137	532 40 75-90	Bumper Dash	235	532 40 61-29	Spacer Fender
150	532 40 66-62	Air Duct	236	873 93 05-00	Nut Lock 5/16-18 unc
151	532 40 78-07	Bracket Pivot	238	532 41 11-19	Trim
152	532 19 95-35	Shield Browning	239	532 40 48-83	Clip Tinnerman
159	817 00 06-12	Screw 3/8-7/16 x 3/4	282	532 41 41-10	Clip Retainer Console
162	532 14 24-32	Screw	283	532 41 63-16	Console Deck Lift
175	532 19 94-72	Crossmember	284	532 41 78-87	Console Shift
176	532 40 07-76	Screw 10-24 x 5/8	285	532 41 63-15	Console Insert RH
177	532 19 52-28	Bushing Steering	286	532 41 63-17	Console Insert LH
180	532 41 46-85	Chassis	287	817 60 04-06	Screw Hex Washhead 1/4-20 x 3/8
182	532 40 71-76	Dash Lower	297	532 40 66-65	Insert Reflective LH
183	874 52 05-20	Bolt Full Thread 5/16-18 x 1-1/4			
189	817 00 05-12	Screw 5/16-18 x 3/4			
191	532 41 65-01	Insert Reflective RH			

**NOTE:** All component dimensions given in U.S. inches  
1 inch = 25.4 mm



TRACTOR - - MODEL NO. LTH126 (96041019900), PRODUCT NO. 960 41 01-99  
DRIVE **40**

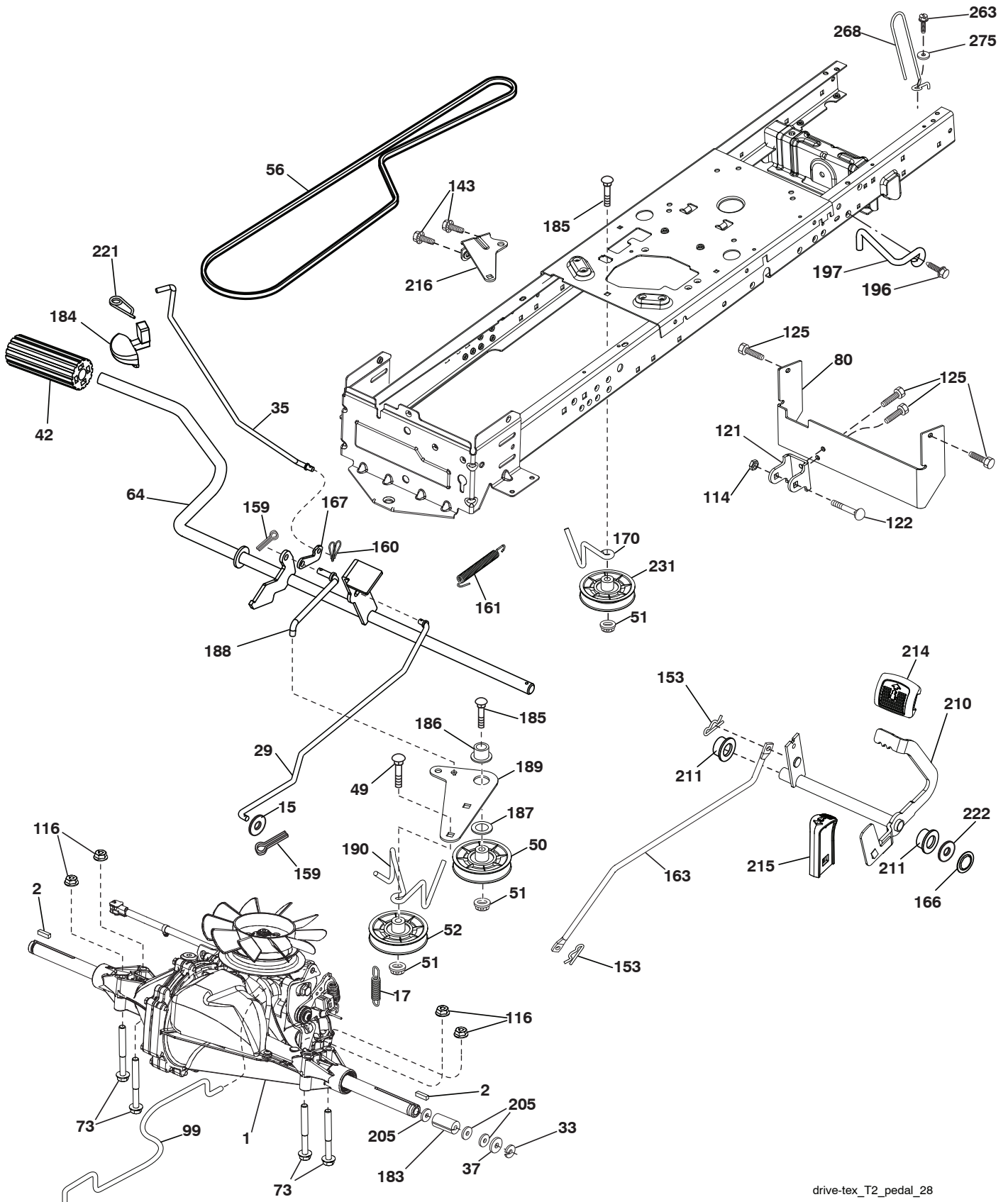

drive-tex\_T2\_pedal\_28

**TRACTOR - - MODEL NO. LTH126 (9604101990), PRODUCT NO. 960 41 01-99**  
**DRIVE 40**

KEY NO.	PART NO.	DESCRIPTION	KEY NO.	PART NO.	DESCRIPTION
1	---	Transaxle, Hydro T2-BABC-1X2B-1GX1 (421645) (Order parts from transaxle manufacturer)	166	532 42 91-64	Nut Push .625
2	532 12 35-83	Key	167	532 40 52-57	Latch Brake Parking
15	819 13 13-16	Washer 13/32 x 13/16 x 16 Ga.	170	532 41 34-30	Keeper Belt Centerspan
17	532 19 72-96	Spring, Brake	183	532 15 69-72	Spacer Axle
29	532 42 32-39	Rod, Brake	184	532 40 97-47	Handle Parking Brake
33	812 00 00-01	Ring E	185	872 11 06-22	Bolt
35	532 40 10-31	Rod, Brake, Park	186	532 19 43-21	Spacer Retainer
37	532 12 17-49	Washer 25/32 x 1-1/4 x 16 Ga.	187	819 13 32-10	Washer
42	532 12 48-72	Cover, Foot Pedal	188	532 19 43-23	Link Clutch Ground Drive
49	872 11 06-14	Bolt	189	532 19 43-17	Bellcrank Ground Drive
50	532 19 43-27	Pulley Idler Flat	190	532 19 43-18	Keeper Bellcrank Ground Drive
51	873 90 06-00	Lock Nut 3/8-16	196	817 00 06-16	Screw 3/8-16 x 1
52	532 19 43-26	Idler V-Groove 910" Offset	197	532 19 58-04	Link Clutch Anti-Rotation
56	532 12 59-07	V-Belt, Drive	205	532 12 17-48	Washer 25/32 x 1-5/8 x 16 Ga.
64	532 19 78-65	Shaft Asm. Pedal Brake Control	210	532 40 09-80	Rockr Asm. Pdeal Control
73	874 49 05-44	Bolt 5/16-18 Gr. 5	211	532 12 01-83	Bearing Nylon
80	581 55 07-01	Strap Torque	214	532 42 12-63	Pad Pedal Forward
99	532 40 84-18	Rod Asm Bypass Spring	215	532 40 17-23	Pad Pedal Reverse
114	873 80 05-00	Nut Lock 5/16-18 unc	216	532 19 61-31	Bracket Pulley Idler
116	873 90 05-00	Nut Lock Hex Flange 5/16-18	221	532 40 31-87	Retainer Spring Clip Handle
121	532 17 56-11	Bracket Strap Torque	222	879 21 20-10	Washer 21/32 x 1-1/4 10 Ga.
122	872 01 05-20	Bolt 5/16-18 x 2.50	231	532 40 72-87	Idler V-Groove 1.688
125	817 00 05-12	Screw 5/16-18 x 3/4	263	817 00 06-12	Screw 3/8-16 x 3/4
143	817 49 05-08	Screw Thdrol 5/16-18 x 1/2	268	819 13 16-14	Washer 13/32 x 1 x 14 Ga.
153	532 12 47-88	Retainer Spring	275	532 18 24-02	Guard Muffler
159	876 02 04-12	Pin Cotter 1/8 x 3/4			
160	532 16 94-84	Retainer Clip			
161	532 10 57-09	Spring, Return, Clutch			
163	532 41 33-22	Rod Pedal Control			

**NOTE:** All component dimensions given in U.S. inches  
1 inch = 25.4 mm

**TRACTOR - - MODEL NO. LTH126 (96041019900), PRODUCT NO. 960 41 01-99  
ENGINE 24**

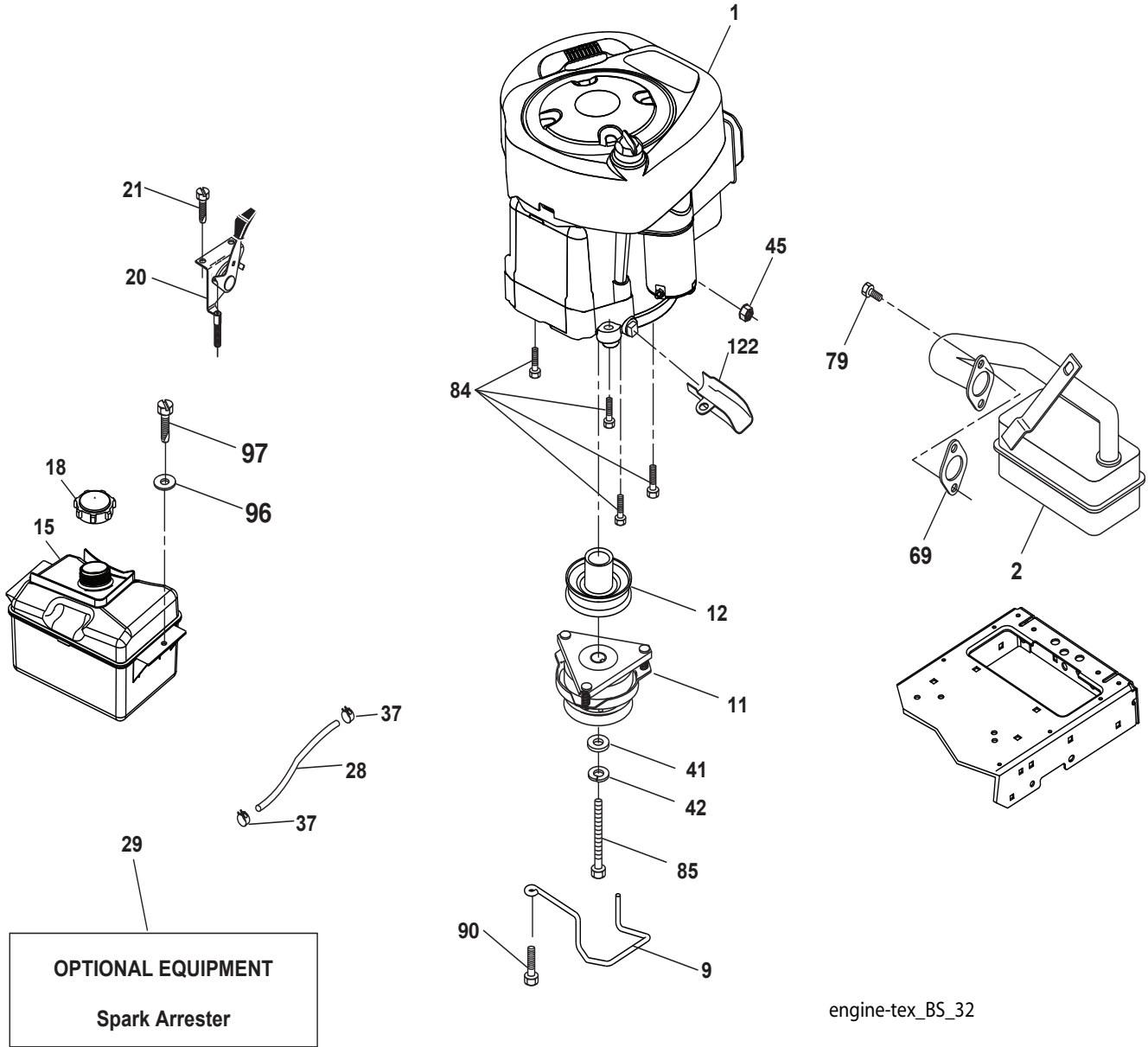

**TRACTOR - - MODEL NO. LTH126 (96041019900), PRODUCT NO. 960 41 01-99  
ENGINE 24**

KEY NO.	PART NO.	DESCRIPTION
1	-----	Engine Briggs Model No. 219807-3376-B1 (438172) (Order parts from engine manufac- turer)
2	532 17 97-58	Muffler
9	532 19 43-19	Keeper Belt Engine
11	532 18 05-05	Clutch Ogura
12	532 19 43-38	Pulley Engine
15	532 40 75-45	Tank Fuel
18	532 43 02-20	Cap Fuel
20	532 18 38-97	Control Throttle
21	532 41 63-58	Screw #10 x 0.750 BOS Thread
28	532 13 70-40	Fuel Line
29	532 13 71-80	Spark Arrester Kit
37	532 12 34-87	Clamp Hose
41	532 12 61-97	Washer 1-1/2 OD x 15/32 ID x 250
42	810 04 07-00	Washer Lock 7/16
45	873 51 04-00	Nut Keps Hex 1/4-20 unc
69	532 16 52-91	Gasket
79	532 19 23-34	Screw 5/16-18 x 3/4
84	817 06 06-20	Screw 3/8-16 x 1/4
85	532 17 39-37	Bolt Hex 7/16-20 x 4 Gr. 5-1.5 THR
90	817 00 06-16	Screw 3/8-16 x 1
96	819 09 14-16	Washer 9/32 x 7/8 x 16 Ga.
97	817 67 04-12	Screw 1/4-20 x 3/4
122	532 42 19-22	Extension Drain Oil

**NOTE:** All component dimensions given in U.S. inches  
1 inch = 25.4 mm

**Engine Power Rating Information**

The gross power rating for individual gas engine models is labeled in accordance with SAE (Society of Automotive Engineers) code J1940 (Small Engine Power & Torque Rating Procedure), and rating performance has been obtained and corrected in accordance with SAE J1995 (Revision 2002-05). Torque values are derived at 3060 RPM; horsepower values are derived at 3600 RPM. Actual gross engine power will be lower and is affected by, among other things, ambient operating conditions and engine-to-engine variability. Given both the wide array of products on which engines are placed and the variety of environmental issues applicable to operating the equipment, the gas engine will not develop the rated gross power when used in a given piece of power equipment (actual "on-site" or net power). This difference is due to a variety of factors including, but not limited to, accessories (air cleaner, exhaust, charging, cooling, carburetor, fuel pump, etc.), application limitations, ambient operating conditions (temperature, humidity, altitude), and engine-to-engine variability. Due to manufacturing and capacity limitations, Briggs & Stratton may substitute an engine of higher rated power for this Series engine.

TRACTOR - - MODEL NO. LTH126 (96041019900), PRODUCT NO. 960 41 01-99  
STEERING ASSEMBLY **41**

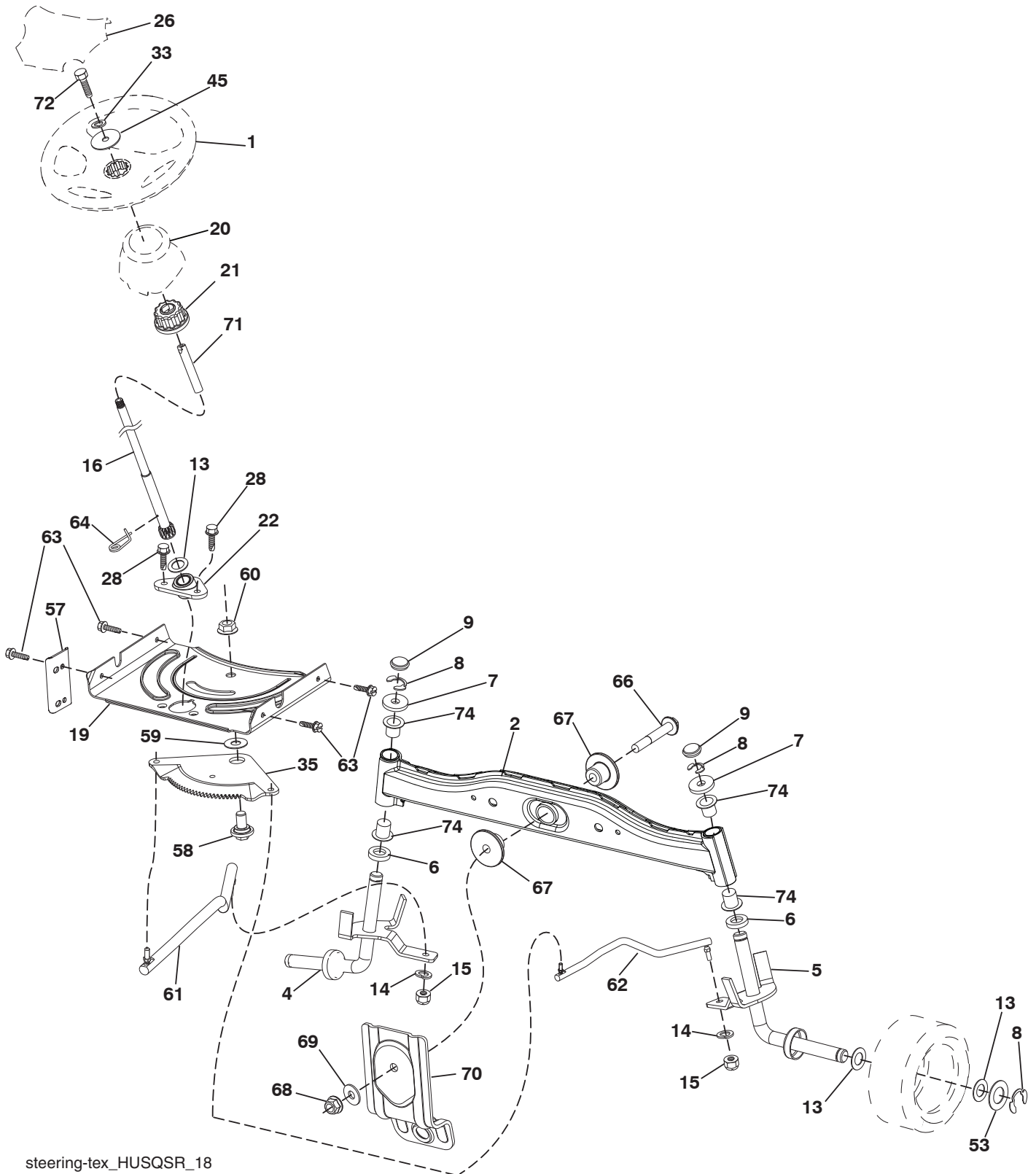

steering-tex\_HUSQSR\_18

**TRACTOR - - MODEL NO. LTH126 (9604101990), PRODUCT NO. 960 41 01-99**  
**STEERING ASSEMBLY 41**

<b>KEY NO.</b>	<b>PART NO.</b>	<b>DESCRIPTION</b>
1	532 41 64-80	Wheel, Steering
2	532 41 81-68	Axle Asm., Front
4	532 41 68-45	Spindle Asm., LH
5	532 41 68-46	Spindle Asm., RH
6	532 12 49-31	Washer Thrust
7	532 12 17-48	Washer 25/32 x 1-5/8 x 16 Ga.
8	812 00 00-29	Ring, Klip #T5304-75
9	532 12 12-32	Cap, Spindle
13	532 12 17-49	Washer 25/32 x 1-1/4 x 16 Ga.
14	810 04 06-00	Washer, Lock Hvy Hlcl Spr 3/8
15	873 54 06-00	Nut, Crown Lock 3/8-24 unf
16	532 42 93-73	Shaft Steering
19	532 19 47-29	Plate Steering
20	532 41 11-39	Boot, Steering
21	532 18 67-37	Adapter, Wheel Steering
22	532 42 05-37	Supt., Strg. Lower
26	532 41 59-87	Insert, Wheel Steering
28	817 00 06-12	Screw 3/8-16 x 3/4
33	810 04 05-00	Washer Lock 5/16
35	532 19 47-32	Gear, Sector Plate
45	819 11 38-12	Washer 11/32 ID x 2 x 3/8 OD x 12 Ga.
53	532 18 89-67	Washer Hardened .793 x 1.637 x .060
57	532 40 74-65	Bracket Upstop
58	532 19 47-47	Bolt Shoulder Sector Pivot CFM
59	532 19 47-48	Washer Thrust Sector Steering
60	873 97 10-00	Nut Flange Lock 5/8-11
61	532 19 47-40	Draglink, LH
62	532 19 47-41	Draglink, RH
63	817 00 05-12	Screw 5/16-18 x 3/4
64	532 19 98-49	Retainer Clip Spring Steering
66	871 02 07-48	Bolt Hex Fghd 7/16-14 x 3 Serr
67	532 19 47-37	Bushing PM Front Axle
68	873 90 07-00	Nut Lock Flange 7/16-14 Gr. 5
69	532 19 91-62	Washer 1.5 x .505 x .118
70	532 41 70-65	Bracket Deck Susp. Front
71	532 19 07-52	Shaft Extension Steering
72	532 42 89-82	Bolt Fin Hx 5/16-18 x 4
74	532 12 49-37	Bearing

**NOTE:** All component dimensions given in U.S. inches  
1 inch = 25.4 mm

TRACTOR - - MODEL NO. LTH126 (96041019900), PRODUCT NO. 960 41 01-99  
MOWER DECK 44

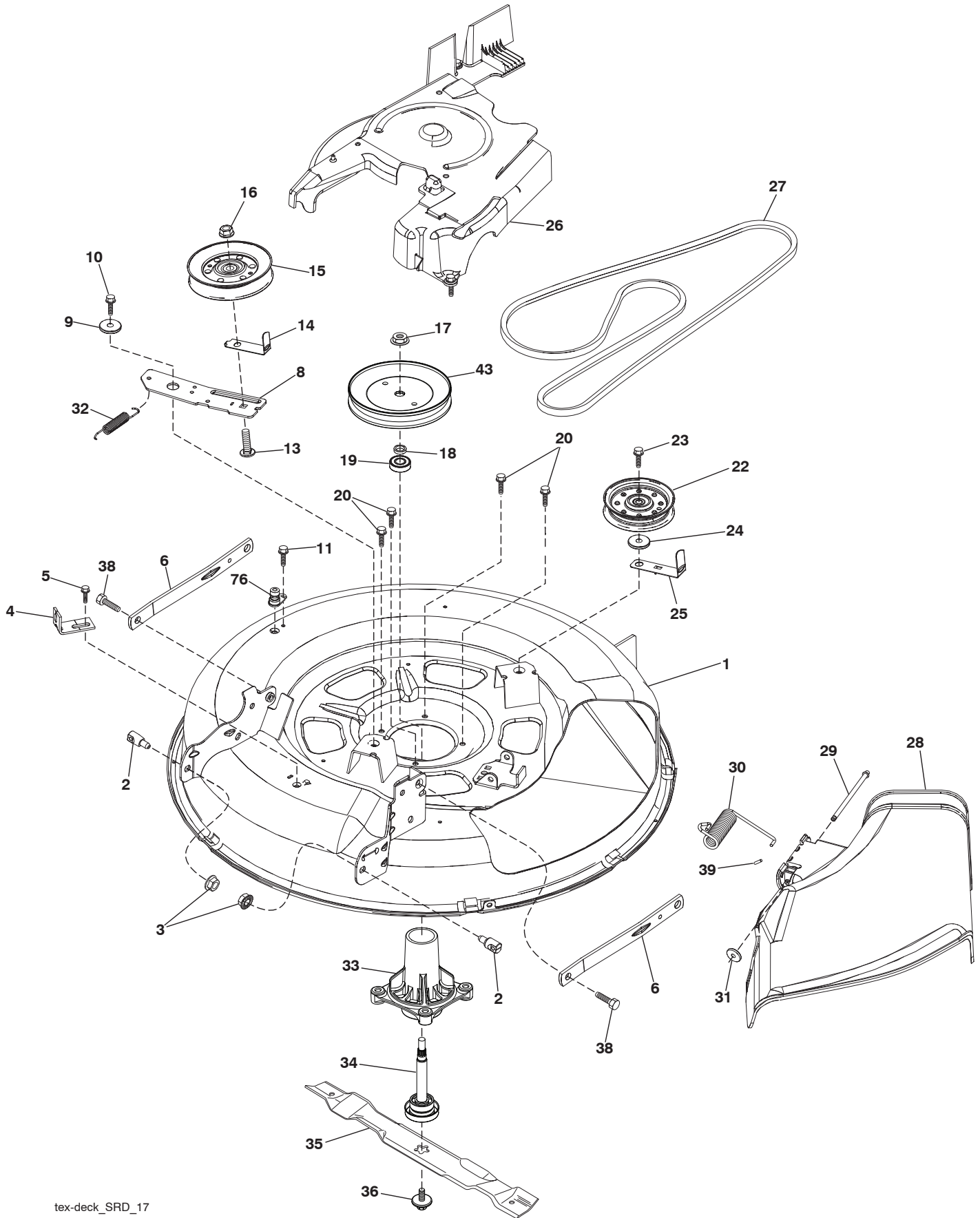

tex-deck\_SRD\_17

**TRACTOR - - MODEL NO. LTH126 (9604101990), PRODUCT NO. 960 41 01-99  
MOWER DECK 44**

KEY NO.	PART NO.	DESCRIPTION	KEY NO.	PART NO.	DESCRIPTION
1	532 43 45-55	Deck Weldment 30" Srd	27	532 41 92-71	V-Belt Drive
2	532 19 51-61	Stud Fastner w/'D'anti-Rotatio	28	532 41 73-44	Shield Asm Deflect Mwr 30s Blk
3	873 90 05-00	Nut Lock Hex Flange 5/16-18	29	532 42 08-95	Pin Hinge 30
4	532 41 76-45	Bracket Clutch Cable	30	532 19 70-26	Spring Torsion Dfl 38/42/46 Gr.
5	817 00 05-10	Bolt 5/16-18	31	532 11 04-52	Nut Push Phos & Oil
6	532 41 88-63	Arm Susp Mower Rear Srd	32	532 19 72-51	Spring Mower Drive Electric
8	532 42 02-52	Arm Idler 30" Srd	33	532 18 72-81	Housing Mandrel 4pt Service
9	532 19 90-92	Spacer Retainer	34	532 19 28-72	Shaft Asm Mndrl N/Greaseable 38
10	817 00 06-16	Screw 3/8 - 16 X 1 Smgml Tap/R Blk	35	532 41 92-73	Blade Mower Hp/Mulch Srd
11	532 13 77-29	Screw Thd Roll 1/4-20 X 5/8	36	532 19 30-03	Bolt/Washer Asm 7/16 - 20 unf
13	872 11 06-12	Bolt Carr Sh 3/8-16 X 1-1/2 Gr. 5	38	532 19 65-39	Bolt Shoulder
14	532 15 60-85	Keeper Belt Idler	39	532 10 53-04	Cap Sleeve
15	532 14 67-63	Pulley Idler V-Groove Dim 4.25	43	532 41 68-77	Pulley Mandrel 6 5 Pd 30"
16	873 90 06-00	Nut Lock FIG 3/8-16 unc	76	532 41 55-98	Washout Port
17	532 40 02-34	Nut Flange Lock Top	--	532 19 28-70	Mandrel Assembly (Includes Hous- ing, Shaft Assembly, And Bearing Only - Pulley/Nut/Washer And Blade Bolt/Washers Not Included)
18	532 18 76-90	Washer Spacer Mandrel			
19	532 11 04-85	Bearing Ball Mandrel			
20	532 17 39-84	Screw Thd Roll Dod Pt Hex	--	532 43 81-09	Replacement Mower Complete
22	532 17 58-20	Pulley Idler Flat Unplated			
23	817 49 06-28	Screw Thdrol 3/8-16 X 1-3/4			
24	819 13 20-12	Washer 13/32 X 1-1/4 X 12 Ga.			
25	532 42 02-53	Keeper Belt 30" Srd			
26	532 43 03-13	Cover Mandrel Mwr 30" Black			

**NOTE:** All component dimensions given in U.S. inches  
1 inch = 25.4 mm



**TRACTOR - - MODEL NO. LTH126 (96041019900), PRODUCT NO. 960 41 01-99**  
**MOWER LIFT 45**

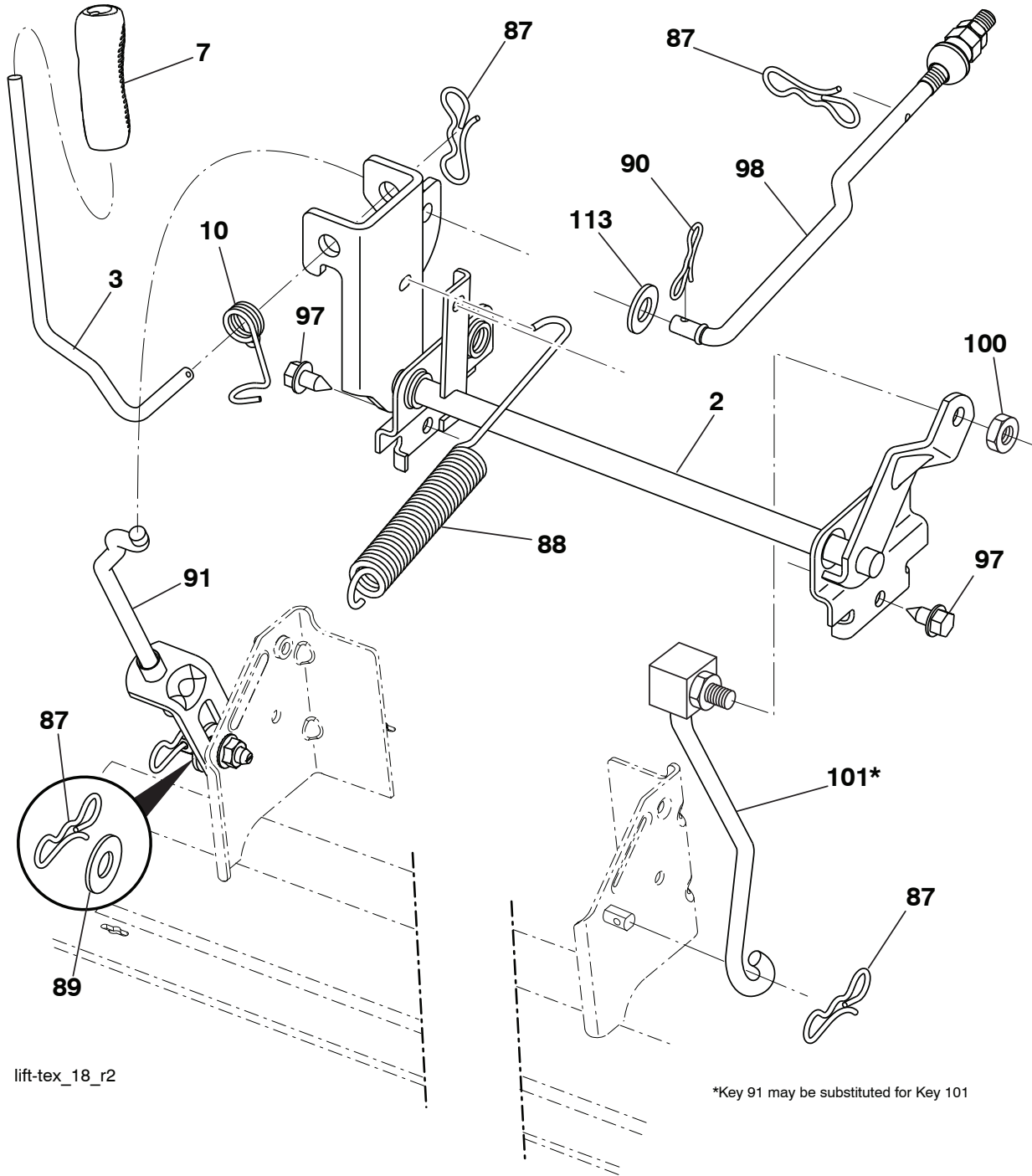

lift-tex\_18\_r2

\*Key 91 may be substituted for Key 101

KEY NO.	PART NO.	DESCRIPTION
2	532 42 20-27	Shaft Asm., Lift
3	532 19 52-31	Lever Asm., Lift RH
7	532 41 15-55	Grip, Lever
10	532 19 63-14	Spring Torsion
87	532 19 42-09	Pin Cotter 7/16 Bow Tie Lock
88	532 41 07-10	Spring Lift Assist
89	819 19 19-12	Washer Clear Zinc
90	532 19 42-08	Pin Cotter 5/16 Bow Tie Lock
91	532 19 51-81	Link Asm Lift LH Rear

KEY NO.	PART NO.	DESCRIPTION
97	817 00 06-12	Screw Hex Wsh. THDR 3/8-16 x 3/4
98	532 19 52-64	Link Lift Susp. Front Mower
100	873 93 06-00	Nut Centerlock 3/8-16 unc
101	532 40 70-03	Link Asm Lift FXD
113	819 17 19-12	Washer 17/32 x 1-3/16 x 12 Ga.

**NOTE:** All component dimensions given in U.S. inches  
 1 inch = 25.4 mm

**TRACTOR - - MODEL NO. LTH126 (9604101990), PRODUCT NO. 960 41 01-99**  
**SEAT ASSEMBLY 42**

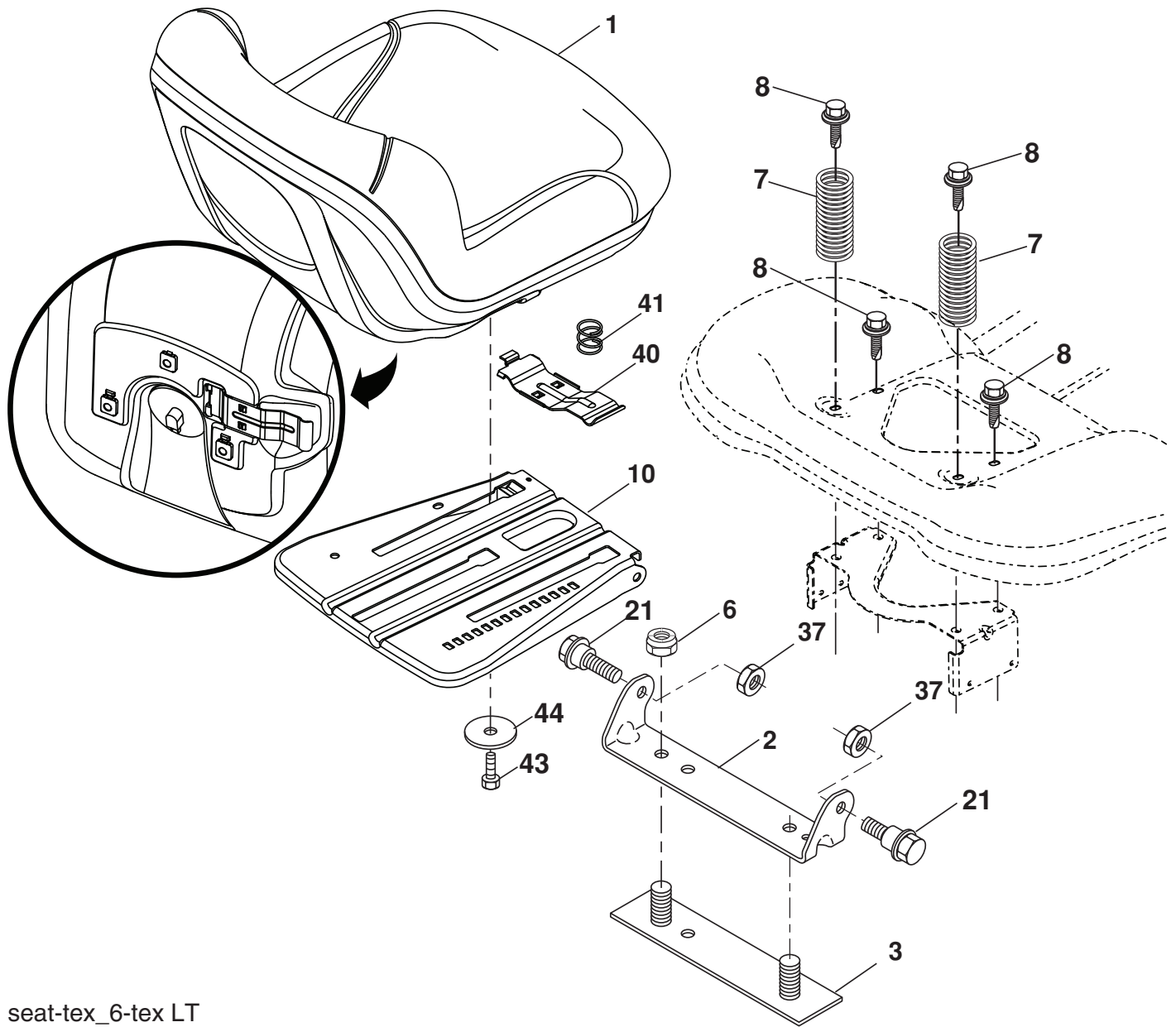

seat-tex\_6-tex LT

KEY NO.	PART NO.	DESCRIPTION
1	532 42 40-67	Seat
2	532 18 01-66	Bracket Pivot Fender
3	532 14 06-75	Strap, Asm Fender
6	873 80 06-00	Nut, Lock w/Ins. 3/8-16 unc
7	532 12 41-81	Spring, Seat Cprsn
8	532 17 18-77	Bolt 5/16-18 unc x 3/4 w/Sems
10	532 19 69-77	Pan, Seat
21	532 17 18-52	Bolt, Shoulder 5/16-18

KEY NO.	PART NO.	DESCRIPTION
37	873 80 05-00	Nut, Lock 5/16-18 unc
40	532 19 76-61	Handle Slide Seat
41	532 19 82-00	Spring Latch Seat
43	874 76 06-12	Bolt Fin Hex 3/8-16 unc x 3/4
44	819 13 38-12	Washer 13/32 x 2-3/8 x 12 Ga.

**NOTE:** All component dimensions given in U.S. inches  
 1 inch = 25.4 mm

