

CTH200 TWIN

Spare parts

Ersatzteile

Pièces détachées

Reserve onderdelen

Repuestos

Reservdelar

ILLUSTRATED PARTS LIST

MODEL NO. 96061026200

CUSTOMER CATALOG NO. CTH200 TWIN

PRODUCT NO. 960 61 02-62

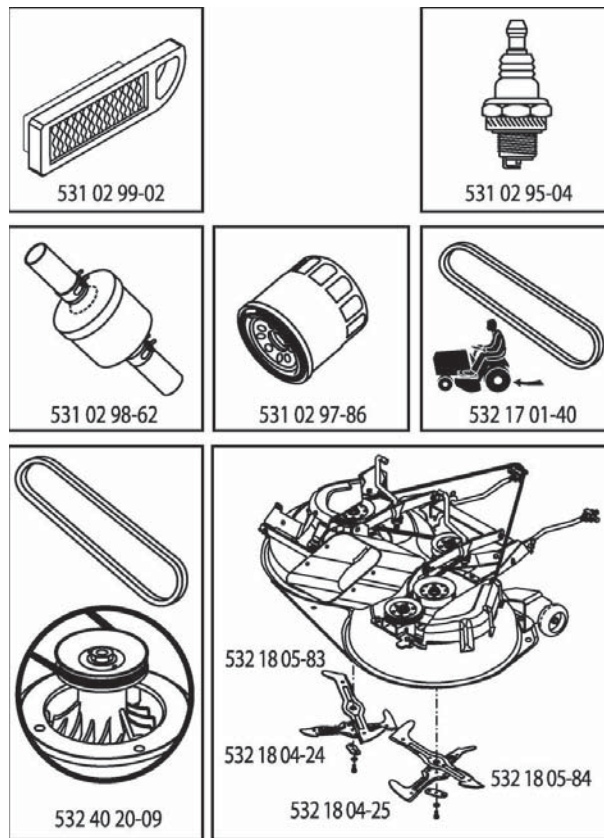

47

408798

**TRACTOR - - MODEL NO. CTH200 TWIN (96061026200), PRODUCT NO. 960 61 02-62
DECALS 27**

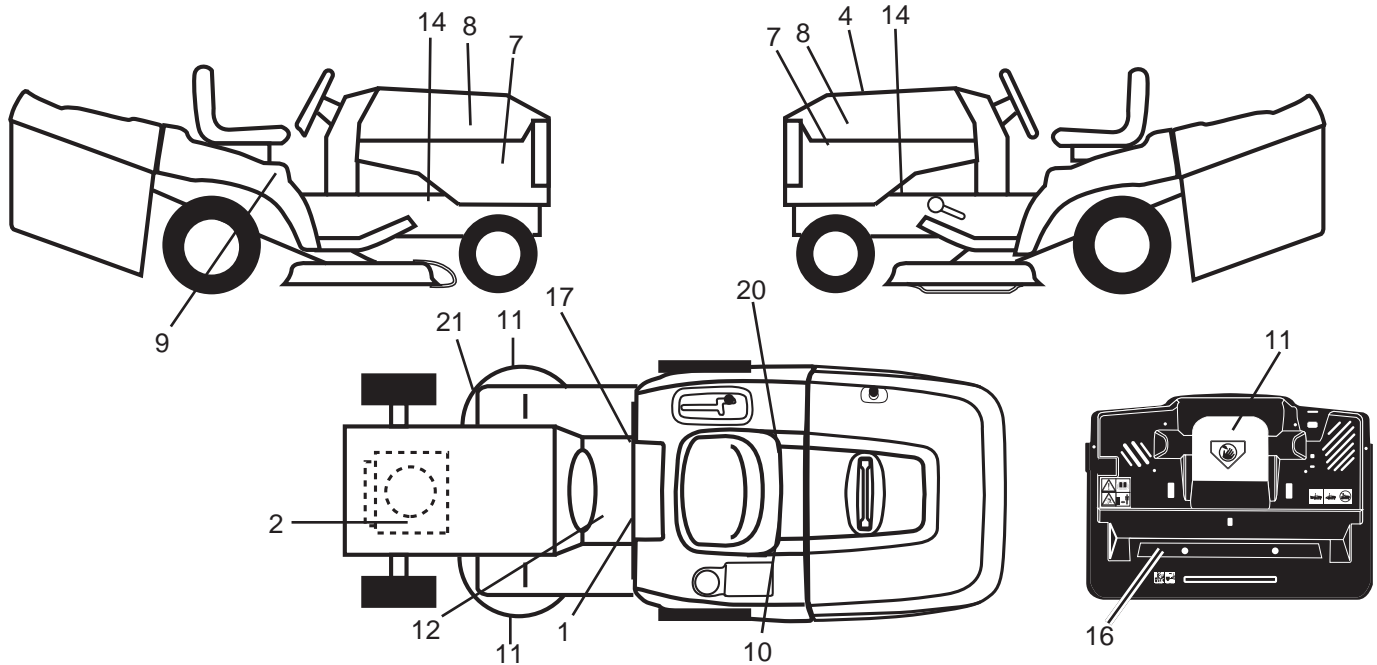

KEY NO.	PART NO.	DESCRIPTION
1	532 40 03-89	Decal, Warning Sym. CE
2	532 19 68-41	Decal, Engine Wrng Symbols
4	532 40 87-98	Decal, Replacement
7	532 41 60-13	Decal, Panel Side
8	532 42 91-96	Decal, Hood
9	532 18 04-32	Decal, Fender Logo
10	532 14 50-05	Decal, Bat Dan/Poi P/L Sym Wp'n
11	532 18 21-66	Decal, Mower Cut Finger Symbol
12	532 15 97-37	Decal, Brake/Clutch Symbol Lt
14	532 15 97-36	Decal, Chassis Hot Muffler
16	532 18 04-35	Decal, Backplate

KEY NO.	PART NO.	DESCRIPTION
17	532 14 08-37	Decal, Saddle Brake Parking
20	532 16 69-60	Decal, Bypass Fender CRD
21	532 16 62-86	Decal, Hex Belt Sch 92 CRD
--	532 13 83-11	Decal, Handle Lift
--	532 18 19-17	Pad Footrest RH
--	532 18 19-16	Pad Footrest LH
--	532 43 28-13	Manual Operator's (Euro)
--	532 43 28-14	Manual Operator's (Scan)
--	532 43 28-15	Manual Operator's (E-Bloc)
--	532 43 28-16	Manual Operator's (Baltic)

WHEELS & TIRES

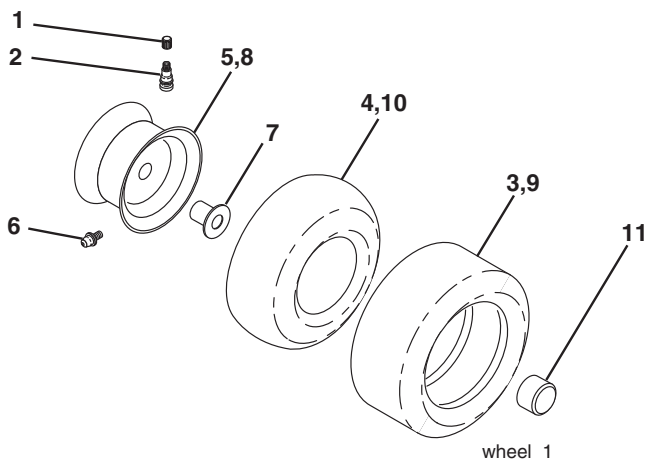

KEY NO.	PART NO.	DESCRIPTION
1	532 05 91-92	Cap Valve Tire
2	532 06 51-39	Stem Valve
3	532 10 62-22	Tire F Ts 15 x 6 0 - 6 Service
4	532 05 99-04	Tube Inner Front #35060
5	532 13 83-36	Rim Asm 6" Front Service
6	532 12 49-57	Fitting Grease
7	532 12 49-59	Bearing Flange
8	532 13 83-37	Rim Asm 8" Rear Service
9	532 12 20-82	Tire R Ts 10 x 8-8 Service
10	532 12 49-26	Tube Rear 9 5 x 8 Service
11	532 17 50-39	Cap Axle Blk 1 50 x 1 00
--	532 14 43-34	Sealant, Tire (10 oz. tube)

NOTE: All component dimensions given in U.S. inches
1 inch = 25.4 mm

TRACTOR - - MODEL NO. CTH200 TWIN (96061026200), PRODUCT NO. 960 61 02-62 SCHEMATIC 38

SCH20

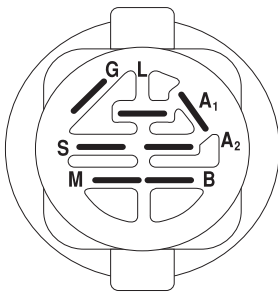
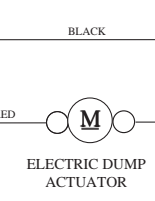
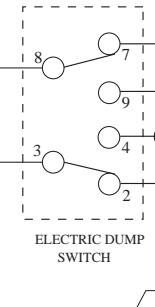
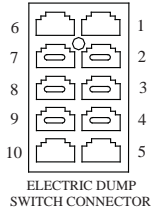
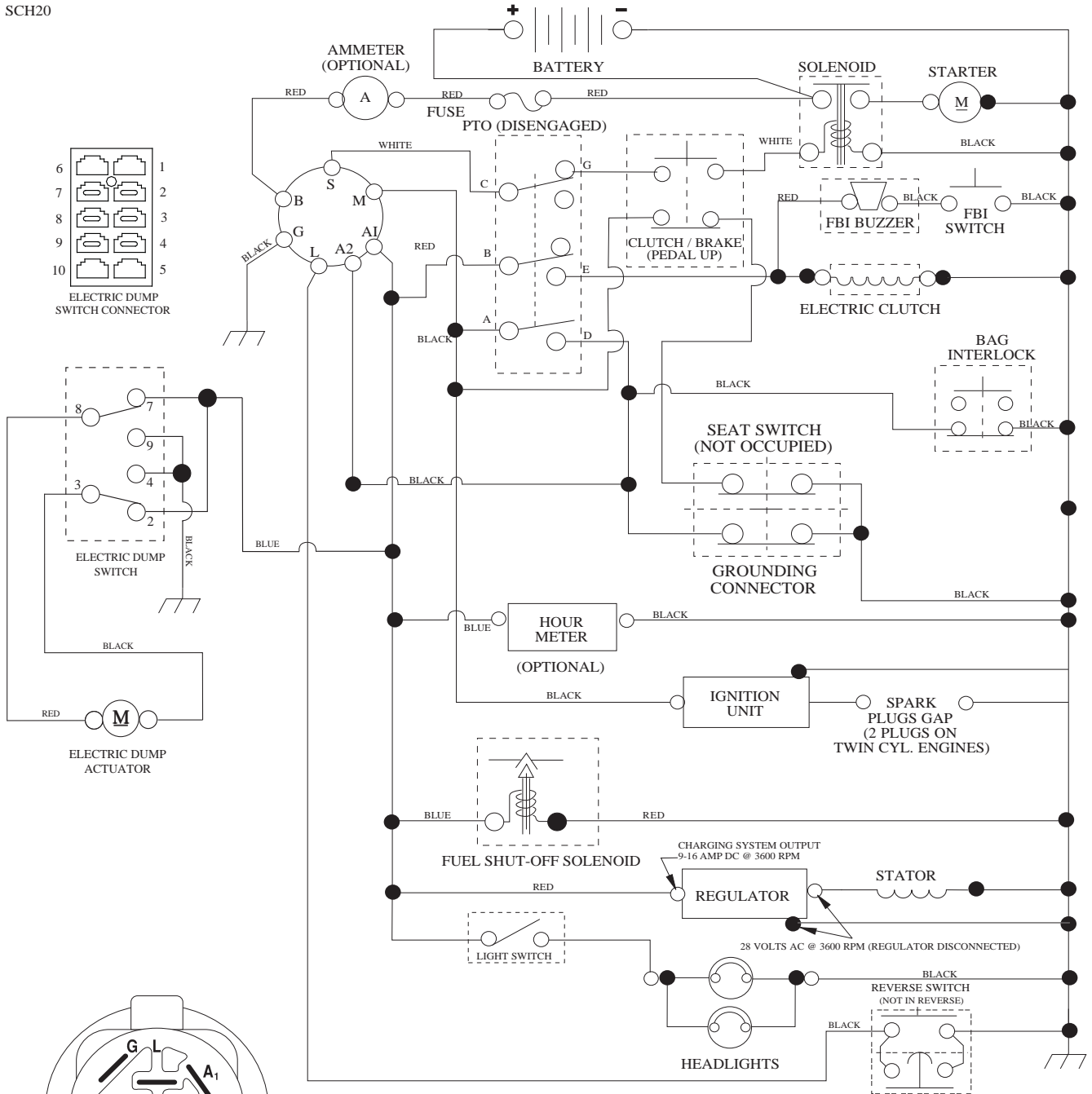

POSITION	CIRCUIT	"MAKE"
OFF	M+G+A1	
RUN/OVERRIDE	B+A1	
RUN	B+A1	L+A2
START	B + S + A1	

WIRING INSULATED CLIPS
NOTE: IF WIRING INSULATED CLIPS WERE REMOVED FOR SERVICING OF UNIT, THEY SHOULD BE RE-INSTALLED TO PROPERLY SECURE YOUR WIRING.

POSITION	CIRCUIT
OFF	C + G, B + H
ON	C + F, B + E, A + D

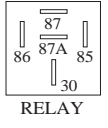

NON-REMOVABLE CONNECTIONS

REMOVABLE CONNECTIONS

03048

TRACTOR - - MODEL NO. CTH200 TWIN (96061026200), PRODUCT NO. 960 61 02-62
ELECTRICAL 32

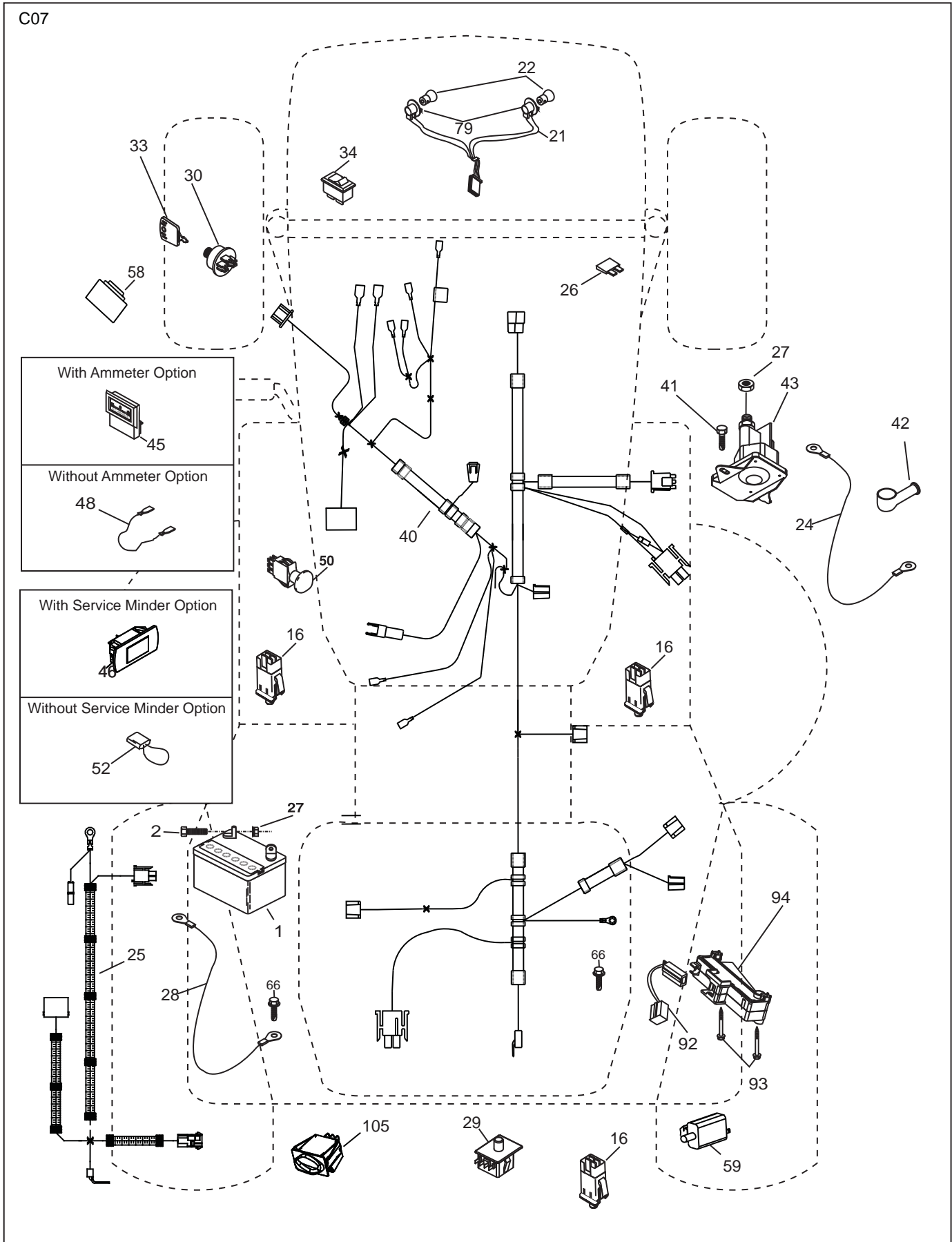

**TRACTOR - - MODEL NO. CTH200 TWIN (96061026200), PRODUCT NO. 960 61 02-62
ELECTRICAL 32**

KEY NO.	PART NO.	DESCRIPTION
1	532 16 34-65	Battery
2	874 76 04-12	Bolt Hex Hd 1/4-20 unc x 3/4
16	532 17 61-38	Switch Interlock
21	532 18 37-59	Harness Asm Light w/4152J
22	532 00 41-52	Bulb Light #1156
24	532 10 84-23	Cable Battery
25	532 42 98-69	Cable Battery
26	532 17 51-58	Fuse
27	873 51 04-00	Nut Keps Hex 1/4-20 unc
28	532 12 77-25	Cable Ground 6 Ga. 18" Black
29	532 19 27-49	Switch Seat
30	532 19 33-50	Switch Ignition
33	532 41 19-35	Key/Chain
34	532 11 07-12	Switch Light/Reset B/B/Red
40	532 42 98-70	Harness Ign
41	871 11 04-08	Bolt Flk Fin Hex 1/4-20 unc x 1/2
42	532 13 15-63	Cover Terminal Red
43	532 19 25-07	Solenoid
46	532 40 17-63	Gauge SRVMNDR Hourmeter
48	532 14 08-44	Adapter Ammeter Rectangular
50	532 17 46-51	Switch PTO
58	532 16 94-19	Buzzer CRD
59	532 18 03-79	Switch FBI CRD
66	817 49 06-08	Screw Thdrol 3/8-16 x 1/2 Ty-Tt
79	532 17 52-42	Socket Asm. Bulb Twistlock
92	532 19 66-15	Harness Pigtail Console ROS
93	532 19 25-40	Screw Plastite 10-14 x 2.0
94	532 19 18-34	Module Reverse ROS
105	532 43 04-44	Switch Rotary

NOTE: All component dimensions given in U.S. inches.
1 inch = 25.4 mm.

TRACTOR - - MODEL NO. CTH200 TWIN (96061026200), PRODUCT NO. 960 61 02-62
CHASSIS AND ENCLOSURES **39**

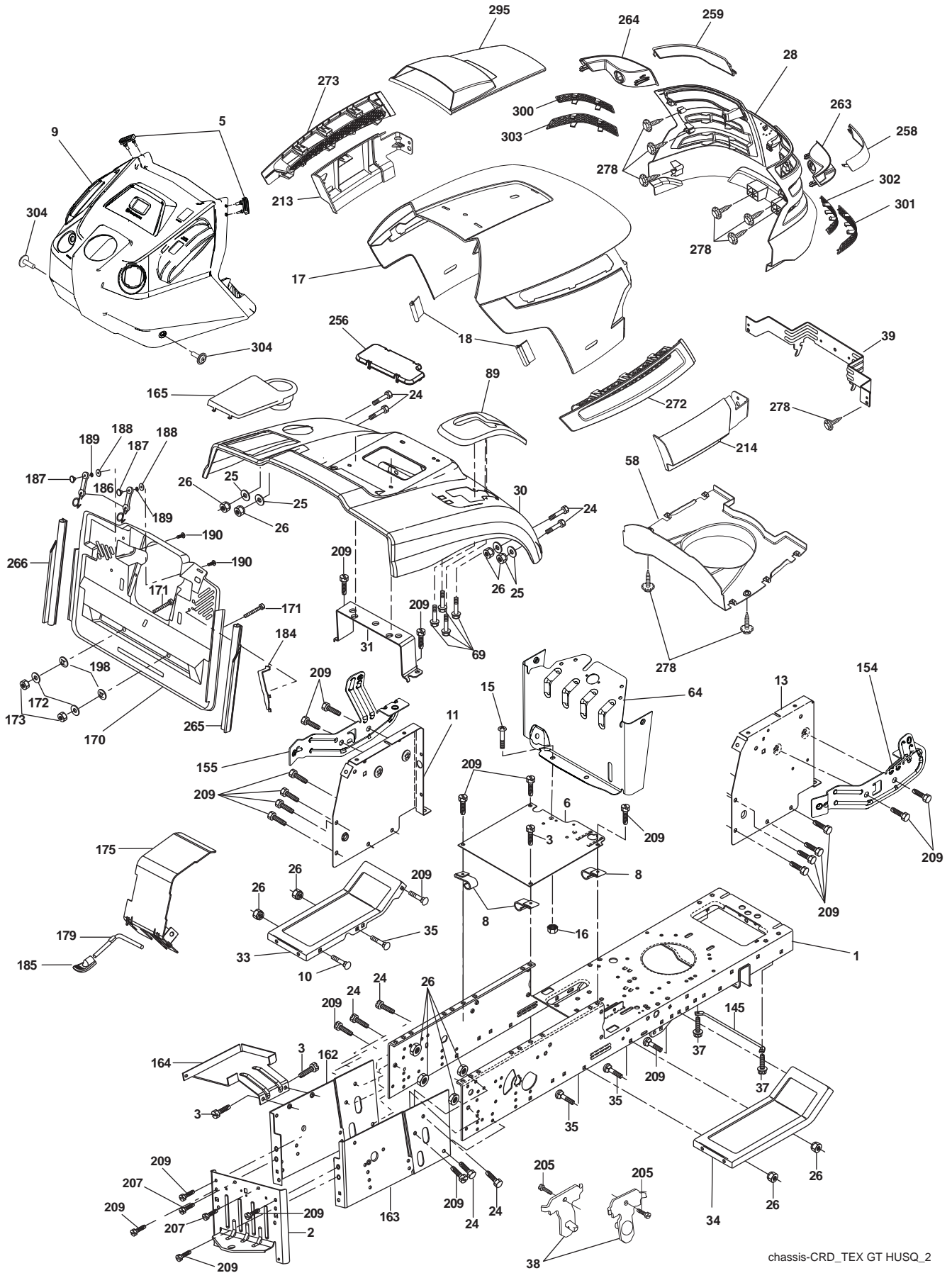

**TRACTOR - - MODEL NO. CTH200 TWIN (96061026200), PRODUCT NO. 960 61 02-62
CHASSIS AND ENCLOSURES **39****

KEY NO.	PART NO.	DESCRIPTION	KEY NO.	PART NO.	DESCRIPTION
1	532 17 46-20	Chassis	171	872 14 06-20	Bolt Rdhd Sqnk 3/8-16x2-1/2Gr.5
2	532 18 03-84	Drawbar	172	819 13 20-16	Washer 13/32 x 1-1/4 x 16 Ga.
3	817 06 06-12	Screw 3/8-16 x 3/4	173	873 51 06-00	Nut, Keps Hex 3/8-16 unc
5	532 40 75-90	Bumper Dash	175	532 18 82-03	Guard Trap
6	532 18 44-19	Saddle	179	532 18 82-02	Rod Pivot FBI CRD
8	532 12 64-71	Clip Insulator 13/32 Mtg. Hole	184	532 17 46-62	Bracket Actuator Bagger CRD
9	532 40 89-11	Dash Upper	185	532 18 11-01	Knob Rod Brake Parking
10	872 14 06-08	Bolt, Carriage 3/8-16 x 3/4	186	532 16 07-93	Latch Asm Mulch/Bagger
11	532 16 72-03	Panel, Dash, LH	187	532 12 50-04	Nut Weld
13	532 17 82-98	Panel, Asm. Dash RH	188	819 06 12-16	Washer #10
15	874 18 05-12	Screw, Machine, THD 5/16-18 unc x 3/4	189	810 07 10-00	Washer Lock #10
16	873 51 05-00	Nut Keps 5/16-18 unc	190	871 08 10-10	Screw Pan Hd Phillip 10-24 x 5/8
17	532 41 10-46	Hood	198	532 16 89-37	Nut, Push
18	532 40 47-42	Bumper Hood	205	817 49 06-08	Screw Thdrol 3/8-16 x 1/2
24	874 78 06-16	Bolt	207	817 67 05-08	Screw Thdrol 5/16-18 x 1/2
25	819 13 13-12	Washer 13/32 x 13/16 x 12 Ga.	209	817 00 06-12	Screw Hex Wsh Thdrol 3/8-16
26	873 80 06-00	Nut	213	532 40 17-11	Skirt Side LH
28	532 40 86-07	Grille/Lens Asm (Includes Key #s 258, 259, 263, 264, 300, 301, 302, 303)	214	532 40 17-09	Skirt Side RH
30	532 19 73-76	Fender	256	532 18 13-61	Cover Fender Rack
31	532 16 51-56	Bracket, Fender Support	258	532 19 89-06	Lens RH
33	532 18 10-57	Footrest, LH	259	532 19 89-07	Lens LH
34	532 18 10-58	Footrest, RH	263	532 19 71-98	Bezel RH
35	872 11 06-06	Bolt	264	532 19 71-99	Bezel LH
37	817 49 05-08	Screw Thdrol 5/16-18 x 1/2 TYT	265	532 18 57-04	Seal RH Side Bagger
38	532 18 17-48	Bracket Asm Pivot Mower Rear	266	532 18 57-03	Seal LH Side Bagger
39	532 41 02-50	Bracket Pivot Hood	272	532 40 30-48	Vent Hood RH
58	532 19 85-12	Duct Air	273	532 40 30-76	Vent Hood LH
64	532 19 93-95	Dash Lower	278	532 41 63-58	Screw #10 x 0.750 BOS Thread
69	532 14 24-32	Screw Hx Wsh Hi-Lo 1/4-1/2	295	532 41 66-13	Vent Top Hood
89	532 19 73-77	Console CRD Auto Grey	300	532 19 91-31	Insert Hex Top LH
145	532 40 91-67	Rod Pivot Hood	301	532 19 91-30	Insert Hex Top RH
154	532 40 86-90	Bracket Mounting Dash RH	302	532 19 91-32	Insert Hex Bottom RH
155	532 40 86-91	Bracket Mounting Dash LH	303	532 19 91-33	Insert Hex Bottom LH
162	532 18 03-82	Bracket Exten Chassis LH CRD	304	817 06 04-10	Hex Tapping Screw
163	532 18 03-83	Bracket Exten Chassis RH CRD			
164	532 16 56-05	Support Battery CRD			
165	532 43 22-76	Cover Battery			
170	532 19 94-88	Backplate CRD			

NOTE: All component dimensions given in U.S. inches.
1 inch = 25.4 mm.

TRACTOR - - MODEL NO. CTH200 TWIN (96061026200), PRODUCT NO. 960 61 02-62
DRIVE **40**

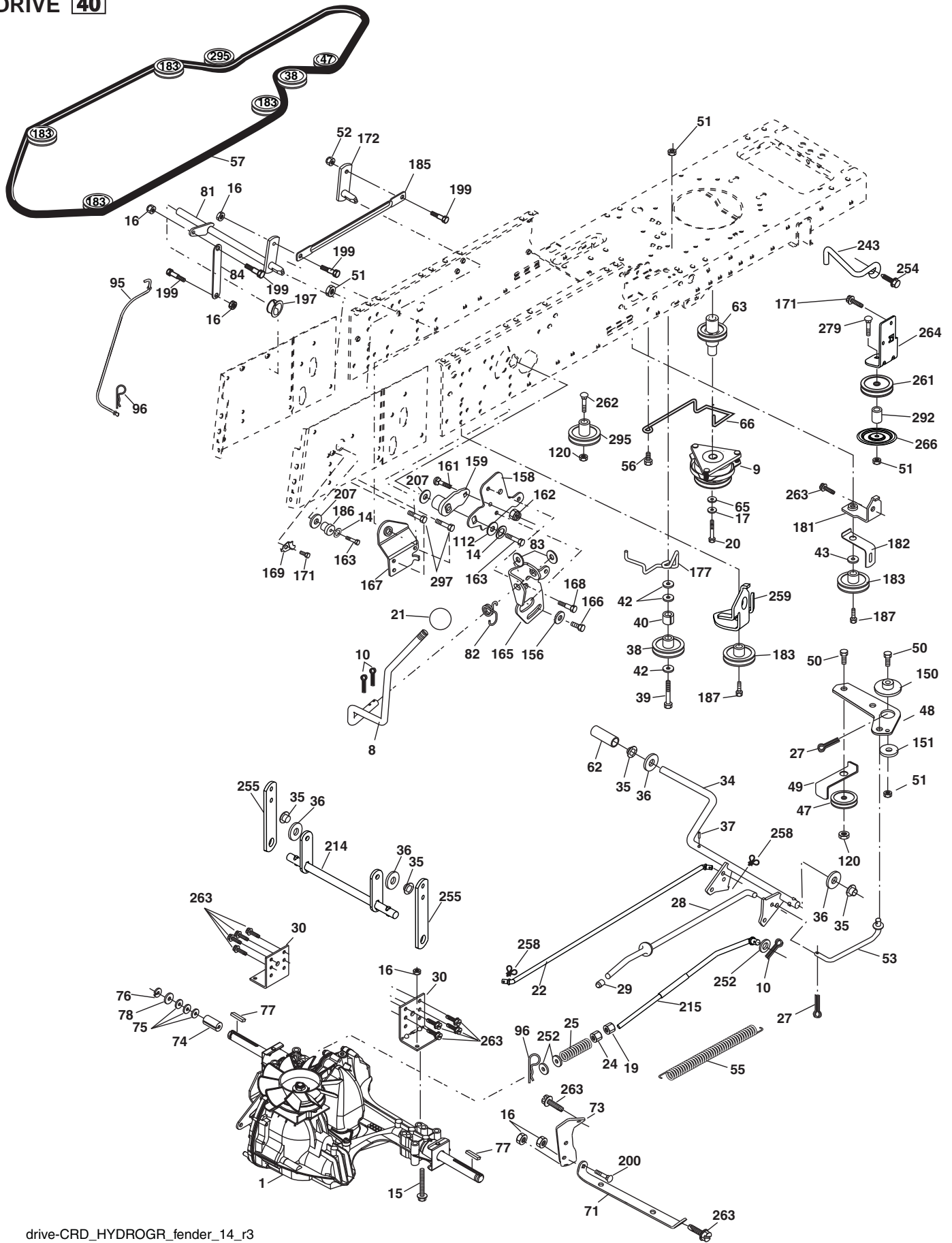

drive-CRD_HYDROGR_fender_14_r3

**TRACTOR - - MODEL NO. CTH200 TWIN (96061026200), PRODUCT NO. 960 61 02-62
DRIVE **40****

KEY NO.	PART NO.	DESCRIPTION	KEY NO.	PART NO.	DESCRIPTION
1	-----	Transaxle Hydro Gear 321-0510	95	532 17 00-15	Control Asm Bypass Hydro
8	532 19 27-06	Rod, Shift Fender Adjust Lt	96	532 12 47-88	Spring, Retainer 1"
9	532 19 81-43	Clutch Electric	112	819 09 12-10	Washer 9/32 x 3/4 x 10 Ga.
10	876 02 04-16	Pin, Cotter 1/8 x 1	120	873 90 06-00	Nut Lock Flg. 3/8-16 unc
14	810 04 04-00	Washer, Lock Hvy Helical	150	532 16 58-50	Bushing, Bellcrank Grnd Dr
15	874 49 05-44	Bolt Hex FGHD 5/16-18 x Gr. 5	151	819 13 32-10	Washer 13/32 x 2 x 10 Ga.
16	873 80 05-00	Nut, Lock Hex w/Ins 5/16-18 unc	156	532 16 60-02	Washer Srrted 5/16 ID x 1.125
17	532 12 61-97	Washer 1-1/2 OD x 15/32 ID x .250	158	532 16 55-89	Bracket Shift Mount
19	873 80 06-00	Nut Lock 3/8-16 unc	159	532 18 39-00	Hub Tapered Flange Shift Lt
20	532 17 39-37	Bolt, Hex 7/16-20 x 4	161	872 14 04-06	Bolt Rdhd Sqnk 1/4-20 x 3/4 Gr. 5
21	532 12 12-74	Knob Duckhead 1/4-13 unc Blk	162	873 68 04-00	Nut Crownlock 1/4-20 unc
22	532 17 56-07	Rod, Brake	163	874 78 04-16	Bolt Hex Fin 1/4-20 unc x 1 Gr. 5
24	873 35 06-00	Nut	165	532 16 56-23	Bracket Pivot Lever
25	532 19 20-36	Spring, Rod, Brake	166	817 49 05-10	Screw 5/16-18 x 5/8
27	876 02 04-12	Pin, Cotter 1/8 x 3/4	167	532 16 55-88	Bracket Support Shift CRD
28	532 17 57-65	Rod, Parking Brake	168	532 16 54-92	Bolt Shoulder 5/16-18 x .561
29	532 12 42-36	Cap, Parking Brake	169	532 16 55-80	Plate Fastening Lt
30	532 16 95-92	Bracket, Mfg. Transaxle	171	817 49 06-08	Screw Thdrol 3/8-16 x 1/2 Ty-Tt
34	532 17 55-78	Shaft, Asm Pedal Foot CRD	172	532 17 02-71	Shaft Asm Shifter Frt CRD
35	532 12 01-83	Bearing, Nylon	177	532 16 59-32	Keeper Flat Idler 3.06" CRD
36	819 21 16-16	Washer 21/32 x 1 x 16 Ga.	181	532 18 02-11	Bracket Idler Ground Drive CRD
37	532 12 49-63	Pin, Roll 3/16 x 1"	182	532 18 26-82	Keeper Belt 2.5" OD V-Idler CRD
38	532 16 59-36	Pulley Flat Composite 3.06"	183	532 19 95-34	Pulley V-Idler CRD
39	874 76 06-44	Bolt Fin Hex 3/8-16 unc x 2-3/4	185	532 17 00-08	Link Shift
40	532 12 49-65	Spacer, Split 395 x 59 Bzp	186	532 16 56-14	Hub Tapered Round CRD
42	819 13 13-12	Washer 13/32 x 13/16 x 12 Ga.	187	817 58 05-20	Screw Thdrol 5/16-18 x 1.25
43	819 11 10-12	Washer 11/32 x 5/8 x 12 Ga.	197	532 16 96-13	Nyliner Snap-In 5/8
47	532 12 77-83	Pulley, Idler, V Groove Plastic	199	532 16 96-12	Bolt Shoulder 5/16-18 unc
48	532 15 44-07	Bellcrank Clutch Grnd Drv	200	872 14 05-08	Bolt RDHD SQNK 5/16-18 x 1
49	532 12 32-05	Retainer, Belt Style Spring	207	532 16 98-45	Washer Nylon Rear
50	872 11 06-12	Bolt Carr SH 3/8-16 x 1-1/2 Gr. 5	214	532 17 56-09	Shaft Asm. Brake
51	873 68 06-00	Nut, Crownlock 3/8-16 unc	215	532 17 56-52	Rod Brake Hydro
52	873 68 05-00	Nut Crownlock 5/16-18	243	532 19 07-36	Bracket Anti-Rotation
53	532 19 96-52	Link, Clutch 7.66	252	819 13 16-16	Washer 13/32 x 1 x 16 Ga.
55	532 10 57-09	Spring, Return, Clutch	254	817 00 06-16	Screw 3/8-16 x 1
56	817 06 06-20	Screw 3/8-16 x 1-1/4	255	532 17 56-08	Brace Shaft Brake Mtg.
57	532 17 01-40	V-Belt Kev 112" 0650 CRD	258	532 17 80-62	Clip Retainer
62	532 12 48-72	Cover, Pedal	259	532 18 02-12	Bracket Pulley IDL Hydro Grd. Dr.
63	532 18 03-97	Pulley, Engine	261	532 13 14-94	Pulley Idler Flat
65	810 04 07-00	Washer	262	872 11 06-22	Bolt Rdhd 3/8-16 unc x 2-3/4 Gr. 5
66	532 15 47-78	Keeper, Belt Engine F-Proof	263	817 00 06-12	Screw HXWSH THDROL 3/8-16 x 3/4 Blk
71	532 16 91-83	Strap, Torque, LH	264	532 19 76-07	Bracket Idler Chassis
73	532 16 91-82	Strap, Torque, RH	266	532 18 20-61	Shield Idler Mower CRD
74	532 13 70-57	Spacer, Split	279	872 11 06-16	Bolt Rdhd Sqnk 3/8-16 unc x 2
75	532 12 17-49	Washer 25/32 x 1-1/4 x 16 Ga.	292	532 40 02-71	Spacer Noram CRD
76	812 00 00-01	Ring, E	295	532 17 91-14	Pulley Idler Composite
77	532 12 35-83	Key, Square	297	817 49 06-10	Screw 3/8-16 x 5/8
78	532 12 17-48	Washer 25/32 x 1-5/8 x 16 Ga.			
81	532 17 00-06	Asm, Shaft			
82	532 16 57-11	Spring, Torsion			
83	819 17 12-16	Washer 17/32 x 3/4 x 16 Ga.			
84	532 17 00-07	Link, Transaxle			

NOTE: All component dimensions given in U.S. inches
1 inch = 25.4 mm

TRACTOR - - MODEL NO. CTH200 TWIN (96061026200), PRODUCT NO. 960 61 02-62
ENGINE **24**

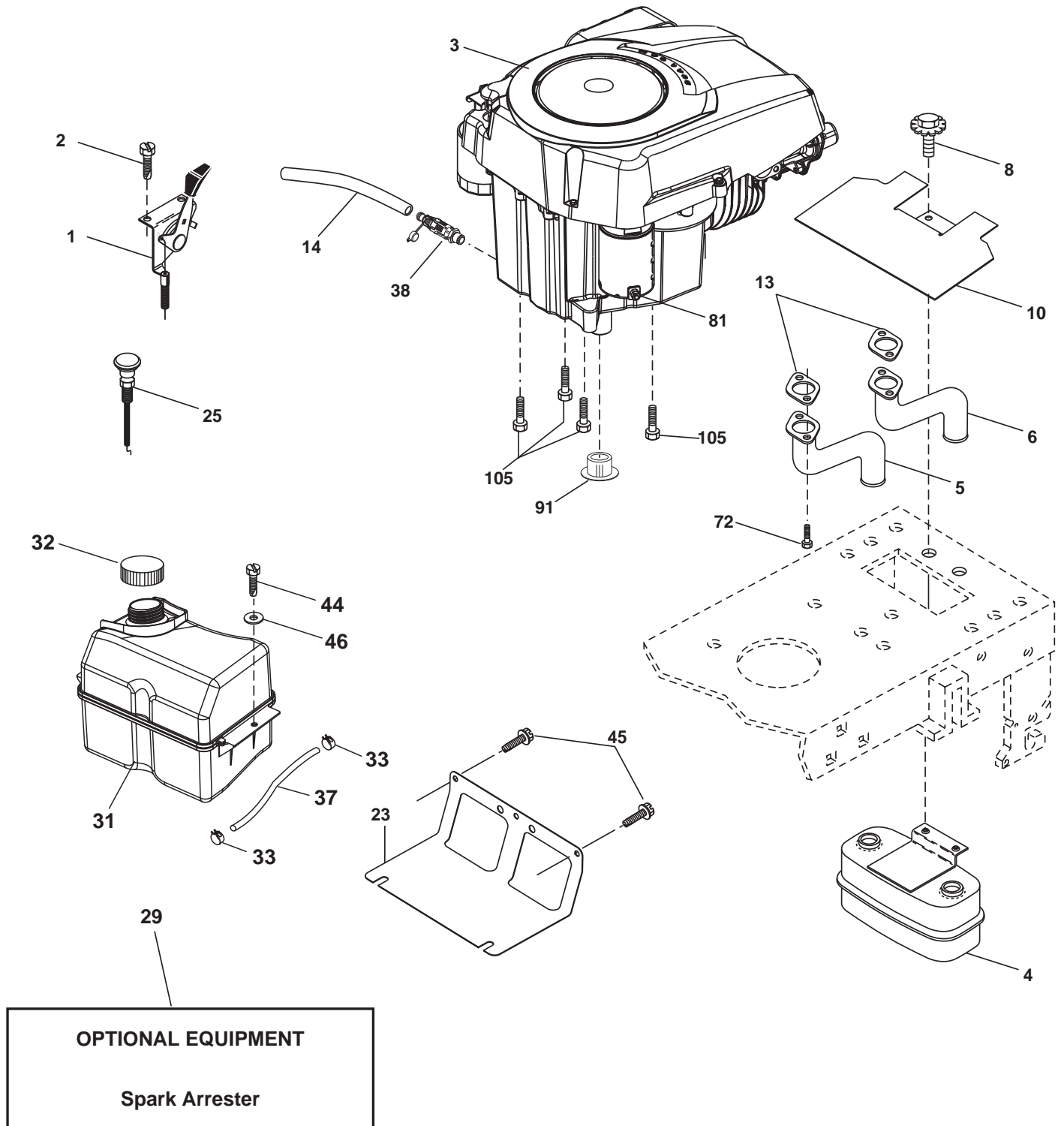

engine-CRD_Kohl_9

**TRACTOR - - MODEL NO. CTH200 TWIN (96061026200), PRODUCT NO. 960 61 02-62
ENGINE 24**

KEY NO.	PART NO.	DESCRIPTION
1	532 18 29-37	Control Throttle
2	532 41 63-58	Screw #10 x 0.750 BOS Thread
3	-----	Engine Kohler SV710-0022
4	532 14 97-23	Muffler Twin Lo-Tone
5	532 14 66-99	Pipe Exhaust LH
6	532 14 67-00	Pipe Exhaust RH
8	532 17 18-77	Bolt 5/16-18 unc x 3/4 w/Sems
10	532 14 66-29	Shield Browning Intek
13	532 18 60-54	Gasket Muffler
14	532 14 84-56	Tube Drain Oil Easy
23	532 16 98-37	Shield Brn/Dbr Guard
25	532 18 95-41	Choke Control
29	532 13 71-80	Kit Spark Arrestor (Flat Scrn)
31	532 40 74-89	Tank Fuel
32	532 43 02-20	Cap Asm Fuel
33	532 12 34-87	Clamp Hose Blk
37	532 13 70-40	Line Fuel
38	532 42 82-87	Valve Oil Drain
44	817 67 04-12	Screw Hexwsh Thdrol 1/4-20 x 3/4
45	817 00 06-12	Screw Hexwsh Thdrol 3/8-16 x 3/4
46	819 09 14-16	Washer 9/32 x 7/8 x 16 Ga.
72	532 19 23-34	Screw Socket HD 5/16-18 x .75
81	873 51 04-00	Nut Keps Hex 1/4-20 unc
91	532 18 74-95	Bushing
105	817 12 06-16	Screw 3/8-16 x 1 SMGML TAP/R

NOTE: All component dimensions given in U.S. inches
1 inch = 25.4 mm

TRACTOR - - MODEL NO. CTH200 TWIN (96061026200), PRODUCT NO. 960 61 02-62
 STEERING ASSEMBLY **41**

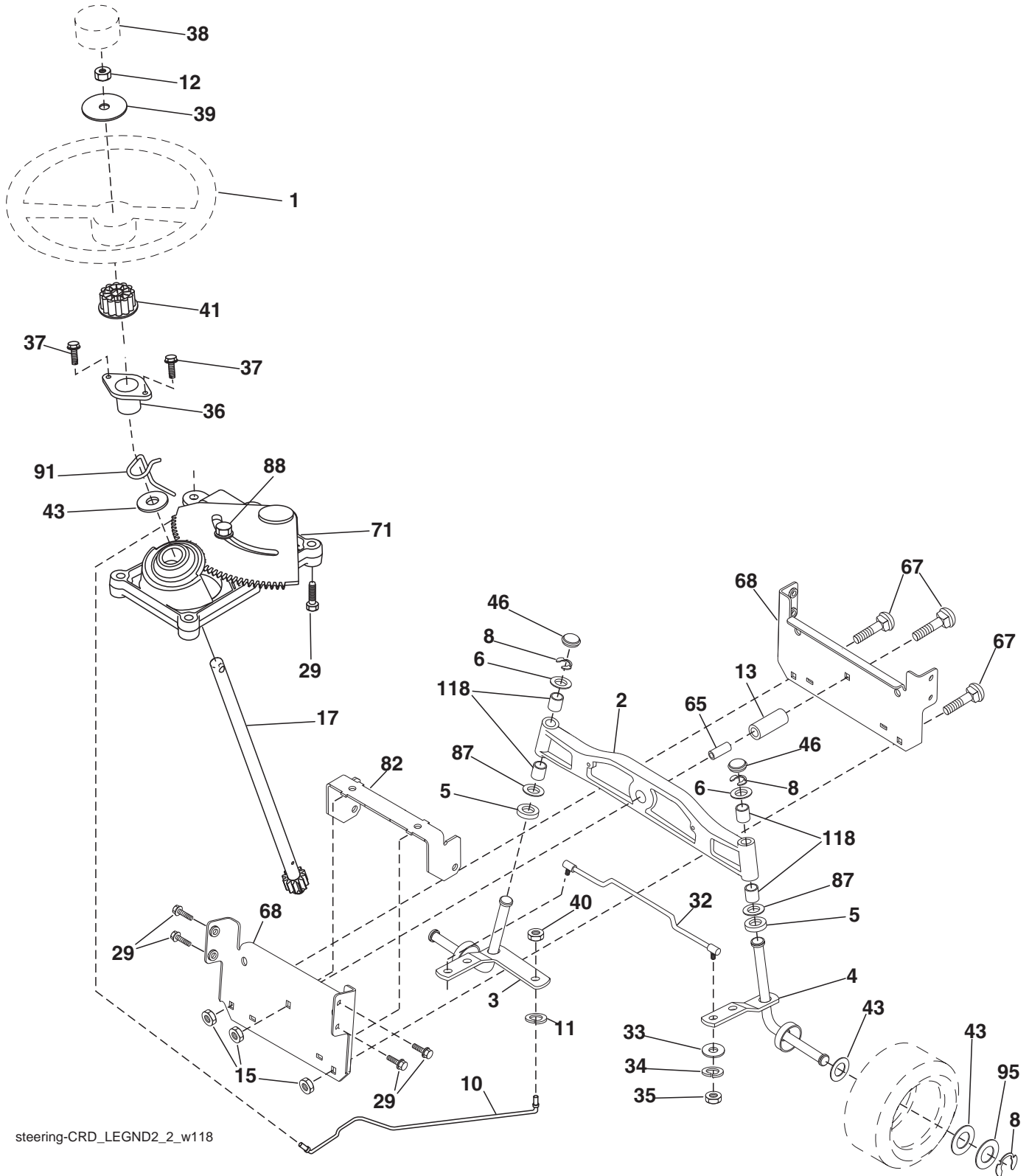

steering-CRD_LEGND2_2_w118

**TRACTOR - - MODEL NO. CTH200 TWIN (96061026200), PRODUCT NO. 960 61 02-62
STEERING ASSEMBLY 41**

KEY NO.	PART NO.	DESCRIPTION
1	532 41 64-80	Wheel Steering
2	532 19 35-42	Front Axle Assembly
3	532 16 98-40	Spindle Assembly, LH
4	532 16 98-39	Spindle Assembly, RH
5	532 12 49-31	Bearing, Race, Thrust, Hardened
6	532 12 17-48	Washer 25/32 x 1-5/8 x 16 Ga.
8	812 00 00-29	Ring, Klip
10	532 17 51-21	Draglink
11	810 04 06-00	Washer, Lock
12	873 94 08-00	Nut Hex Gr. 2 Toplock 1/2-20 unf
13	532 13 65-18	Spacer Axle
15	532 14 52-12	Nut Hex Flange Lock
17	532 17 78-83	Shaft Assembly, Steering
29	817 00 06-12	Screw 3/8-16 x 3/4
32	532 17 18-88	Rod, Tie
33	819 11 12-16	Washer 11/32 x 3/4 x 16 Ga.
34	810 04 05-00	Washer Lock Hvy Hlcl Spr 5/16
35	873 54 05-00	Crownlock Nut 5/16-24 unf
36	532 15 51-05	Bushing, Steering
37	532 15 29-27	Screw TT #10-32 x 5 x 3/8 Flange
38	532 41 59-87	Cap Wheel Steering
39	819 18 38-12	Washer 11/32 ID x 2-3/8 OD x 12 Ga.
40	873 54 06-00	Nut Crownlock 3/8-24
41	532 18 67-37	Adaptor, Steering Wheel
43	532 12 17-49	Washer 25/32 x 1-1/4 x 16 Ga.
46	532 12 12-32	Cap, Spindle
65	532 41 47-36	Spacer Axle
67	872 11 06-18	Bolt Rdhd Sq 3/8-16 x 2-1/4
68	532 16 98-27	Brace Axle
71	532 17 51-46	Steering Asm.
82	532 19 99-78	Bracket Susp. Chassis Front
87	532 17 39-66	Washer Flat .781 x 1-1/2 x .14
88	532 17 51-18	Bolt Shoulder 7/16-20 unc
91	532 17 55-53	Clip Steering
95	532 18 89-67	Washer Hardened
118	532 40 60-13	Bushing

NOTE: All component dimensions given in U.S. inches.
1 inch = 25.4 mm.

TRACTOR - - MODEL NO. CTH200 TWIN (96061026200), PRODUCT NO. 960 61 02-62
 MOWER DECK **44**

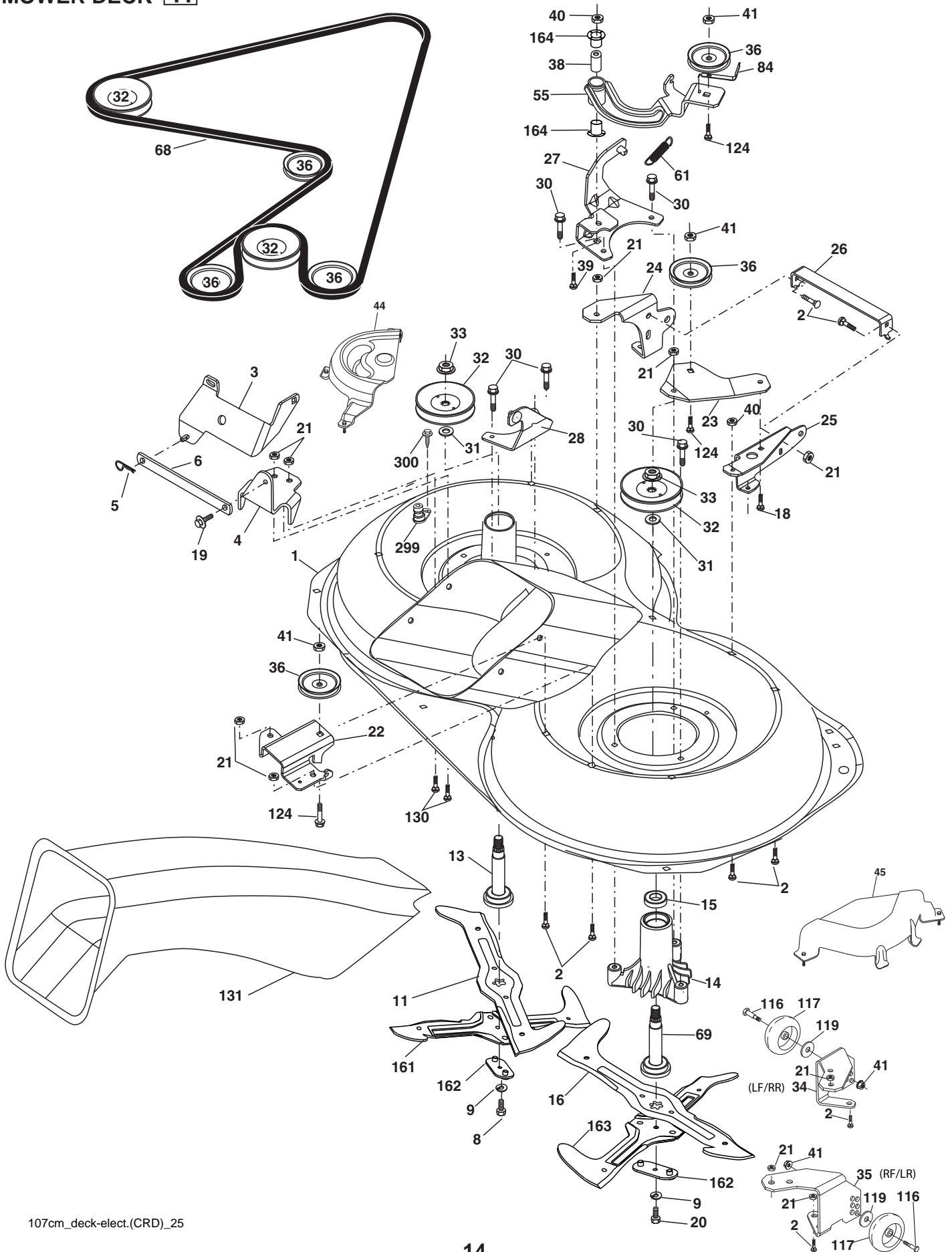

**TRACTOR - - MODEL NO. CTH200 TWIN (96061026200), PRODUCT NO. 960 61 02-62
MOWER DECK 44**

KEY NO.	PART NO.	DESCRIPTION	KEY NO.	PART NO.	DESCRIPTION
1	532 16 91-60	Housing Asm. Mower	44	532 43 27-73	Cover Mandrel LH
2	872 14 05-06	Bolt Rdhd Sqnk 5/16-18 unc x 3/4	45	532 43 27-72	Cover Mandrel RH
3	532 43 18-64	Bracket Asm. S-Bar Chass	55	532 16 98-49	Arm Idler
4	532 16 91-67	Bracket Bar Sway Deck	61	532 19 94-87	Spring Tension Belt
5	532 12 46-70	Retainer Spring	68	532 40 20-09	Belt Drive
6	532 16 55-57	Bar Sway	69	532 16 54-82	Shaft Asm w/Lwr Brg RH Thd CRD
8	532 18 17-12	Bolt 3/8-24 x 1.25 Gr. 8 Patched	84	532 15 60-85	Keeper Belt Idler
9	810 03 06-00	Washer Lock Hvy 3/8 Unplated	116	532 19 34-06	Bolt Shoulder
11	532 18 05-83	Blade 3-1 LH	117	532 17 48-73	Wheel Gauge
13	532 13 76-45	Shaft Asm. w/Lower Bearing	119	819 13 20-12	Washer 3/8 x 7/8 x 14 Ga.
14	532 12 87-74	Housing Mandrel Vented (Machd)	124	872 11 06-12	Bolt Carr Sh 3/8-16 x 1-1/2 Gr. 5
15	532 11 04-85	Bearing Ball Mandrel	130	872 11 05-06	Bolt Rdhdsqnk 5/16-18 unc x 3/4
16	532 18 05-84	Blade 3-1 RH	131	532 16 56-61	Chute Bagger CRD 92cm
18	872 11 06-06	Bolt RDHDSHTSQNK 3/8-16x3/4	161	532 18 04-24	Blade Cross LH 107
19	532 13 28-27	Bolt Shoulder 5/16-18 Thd Form	162	532 18 08-78	Adapter Weldment Blade 107
20	532 18 17-13	Bolt 3/8-24 x 1.25 Gr. 8 Ptch Lhthd	163	532 18 04-25	Blade Cross RH 107
21	873 68 05-00	Nut Crown Lock 5/16-18	164	532 12 49-37	Bearing
22	532 16 91-65	Bracket Idler Sprt RR	299	532 41 55-98	Port Washout
23	532 16 91-66	Bracket Idler Sprt RF	300	532 15 29-27	Screw TT #10-32.5 3/8 Flange
24	532 41 34-36	Bracket Suspension LH	---	532 18 18-57	Mandrel Assembly (Includes housing, shaft assembly, and bearing only - pulley/nut/washer and blade bolt/washers not included).
25	532 40 01-05	Bracket Suspension RF	---	532 18 18-58	Mandrel Asm CRDLH Threads VC
26	532 40 01-10	Brace Support Susp Frt CRD	---	532 43 23-01	Replacement Mower Complete (Std. Deck - Order separately gauge wheel components key nos. 116-119).
27	532 16 91-72	Bracket Asm. Susp RR			
28	532 16 91-68	Bracket Asm. Susp LR			
30	532 17 39-84	Screw Thd Rolling Dod. PT Hex			
31	532 18 76-90	Washer Spacer Mandrel			
32	532 19 81-45	Mandrel Pulleys			
33	532 40 02-34	Nut Flg Top Lock			
34	532 40 01-03	Bracket Gauge Wheel LF/RR			
35	532 40 01-04	Bracket Gauge Wheel RF/LR			
36	532 14 67-63	Pulley Idler V-Groove Dim 4.25			
38	532 16 98-51	Spacer Hub Arm Idler			
39	872 11 06-22	Bolt RhHd 3/8-16 unc x 2-3/4 Gr. 5			
40	873 68 06-00	Nut Crownlock 3/8-16 unc			
41	873 90 06-00	Nut Flangelock 3/8-16 unc			

NOTE: All component dimensions given in U.S. inches
1 inch = 25.4 mm

TRACTOR - - MODEL NO. CTH200 TWIN (96061026200), PRODUCT NO. 960 61 02-62
MOWER LIFT 45

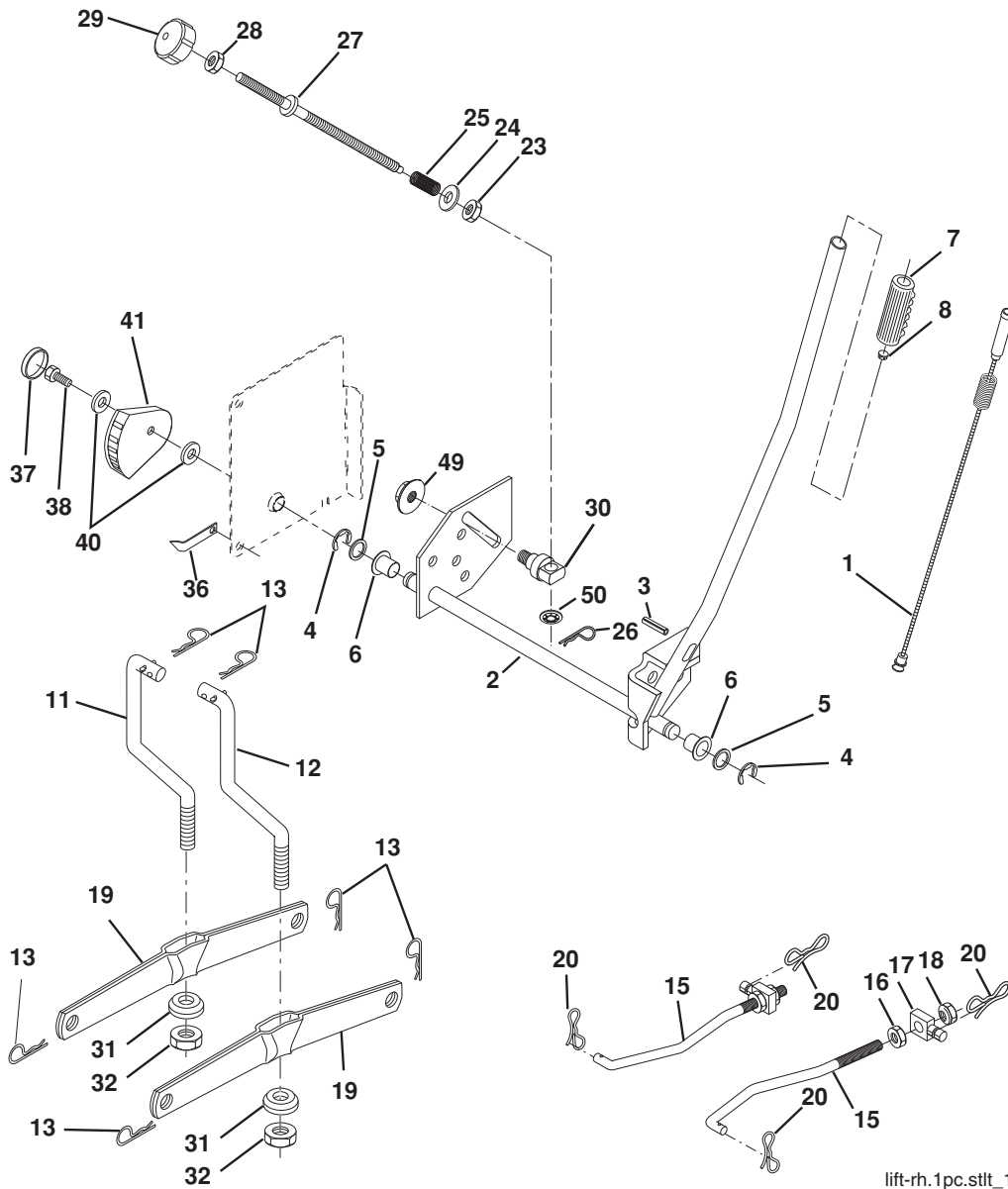

KEY NO.	PART NO.	DESCRIPTION
1	532 40 50-07	Plunger Asm.
2	532 19 80-70	Shaft Asm. Lift RH
3	532 18 88-22	Pin Groove
4	812 00 00-02	E Ring #5133-62
5	819 21 16-21	Washer 21/32 x 1 x 21 Ga.
6	532 12 01-83	Bearing Nylon
7	532 12 56-31	Grip Handle Fluted
8	532 12 23-65	Button Plunger Black
11	532 16 58-29	Link Asm Lift LH
12	532 16 58-31	Link Asm Lift RH
13	532 12 46-70	Retainer Spring
15	532 17 32-88	Link Front
16	873 35 08-00	Nut Jam Hex 1/2-13 unc
17	532 17 56-89	Trunnion Blk Zinc
18	873 80 08-00	Nut Lock w/Wsh 1/2-13 unc
19	532 13 98-68	Arm Suspension Mower
20	532 19 42-09	Pin Cotter Bowtie Lock
23	532 11 08-07	Nut Special
24	819 13 10-16	Washer 13/32 x 5/8 x 16 Ga.

KEY NO.	PART NO.	DESCRIPTION
25	532 16 40-24	Spring
26	532 16 94-84	Retainer Clip
27	532 16 45-43	Rod Adj Lift
28	873 35 06-00	Nut Hex Jam 3/8-16 unc
29	532 13 80-57	Knob Inf 3/8-16 unc Blk w/sym
30	532 15 02-33	Trunnion Infin Height
31	532 16 98-65	Bearing, Pvt. Lift.
32	873 54 06-00	Nut Crownlock 3/8-24
36	532 15 50-97	Pointer Height Indicator
37	532 12 39-35	Plug Hole Blk 1.485/1.515 Dia
38	817 06 05-16	Screw 5/16-18 x 1
40	819 11 24-10	Washer 11/32 x 1-1/2 x 10 Ga.
41	532 12 39-34	Scale Ind Height Blk
49	532 14 52-12	Nut Hex Flange Lock
50	532 11 04-52	Nut Push Phos & Oil

NOTE: All component dimensions given in U.S. inches
 1 inch = 25.4 mm

**TRACTOR - - MODEL NO. CTH200 TWIN (96061026200), PRODUCT NO. 960 61 02-62
SEAT ASSEMBLY 42**

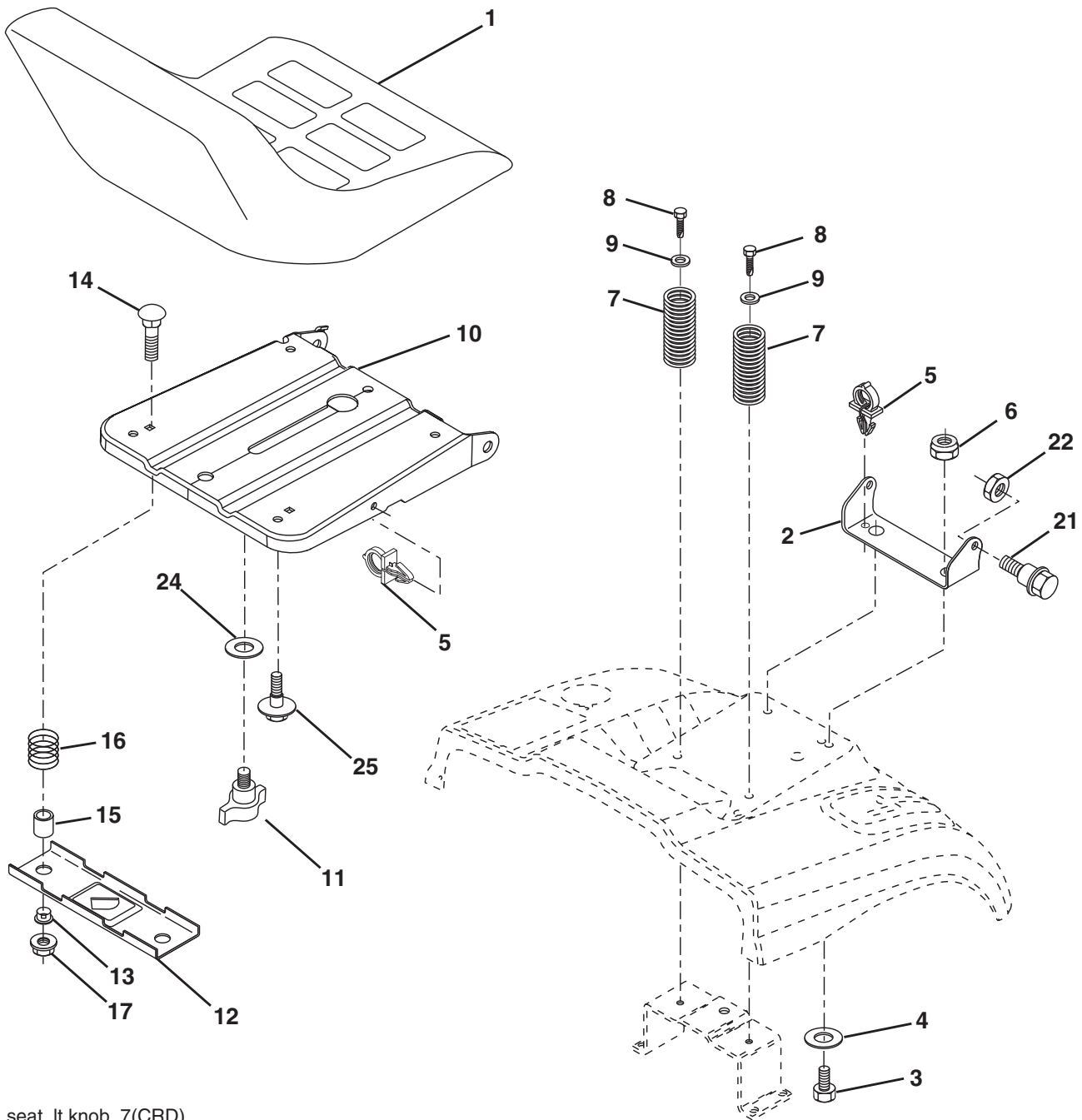

seat_lt.knob_7(CRD)

KEY NO.	PART NO.	DESCRIPTION	KEY NO.	PART NO.	DESCRIPTION
1	532 18 87-15	Seat	13	532 12 12-48	Bushing Snap Blk Nyl 50 Id
2	532 14 05-51	Bracket Pnt Pivot Seat (Blk)	14	872 05 04-12	Bolt Rdhd Sht Nk 1/4-20 x 1-1/2
3	871 11 06-16	Bolt Fin Hex 3/8-16 x 1 Blk	15	532 12 12-49	Spacer Split
4	819 13 16-10	Washer Flat 13/32 x 1 x 10 Ga.	16	532 12 37-40	Spring Cprsn
5	532 14 50-06	Clip Push In Hinged	17	532 12 39-76	Nut Lock 1/4 Lge Flg Gr. 5 Zinc
6	873 80 06-00	Nut Lock Hex w/Insert 3/8-16	21	532 17 18-52	Bolt Shoulder 5/16-18 unc-2A
7	532 12 41-81	Spring Seat Cprsn 2.250 Blk Zi	22	873 80 05-00	Nut Hex Lock w/Ins 5/16-18
8	817 00 06-16	Screw 3/8-16 x 1.5	24	819 17 19-12	Washer 17/32 x 1-3/16 x 12 Ga.
9	819 13 16-14	Washer 13/32 x 1 x 14 Ga.	25	532 12 70-18	Bolt Shoulder 5/16-18 x 62
10	532 19 55-30	Pan Pnt Seat			
11	532 16 63-69	Knob Seat Adj. Wingnut			
12	532 17 46-48	Bracket Pnt Mounting Switch			

NOTE: All component dimensions given in U.S. inches.
1 inch = 25.4 mm

TRACTOR - - MODEL NO. CTH200 TWIN (96061026200), PRODUCT NO. 960 61 02-62
BAGGER **46**

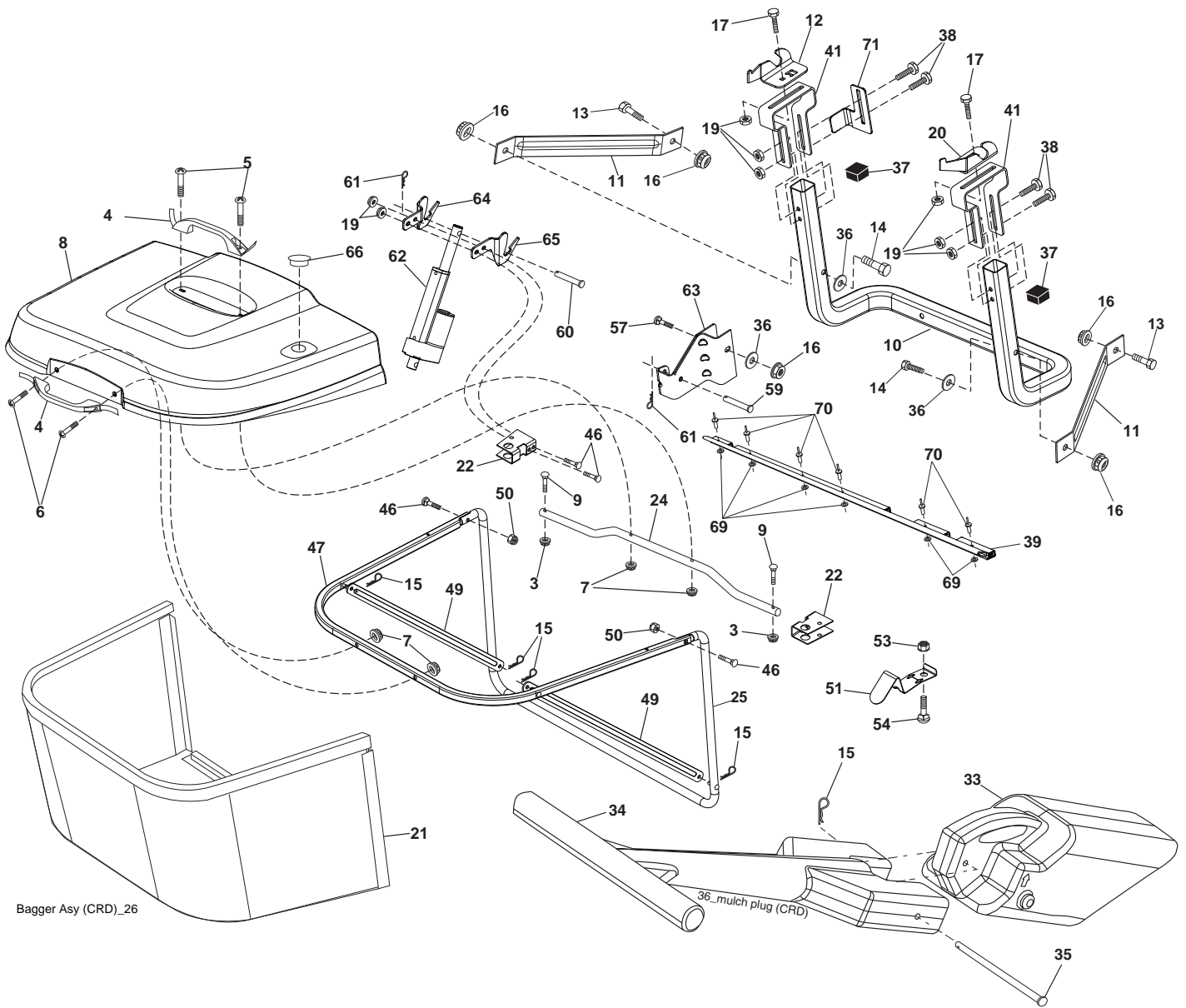

Bagger Asy (CRD)_26

**TRACTOR - - MODEL NO. CTH200 TWIN (96061026200), PRODUCT NO. 960 61 02-62
BAGGER 46**

KEY NO.	PART NO.	DESCRIPTION	KEY NO.	PART NO.	DESCRIPTION
3	532 12 39-76	Nut Lock 1/4 Lge Flg Gr. 5 Zinc	38	872 01 05-20	Bolt 5/16-18 x 2-1/2
4	532 16 99-16	Handle Bagger w/Lvrs Blk CRD	39	532 41 62-57	Seal
5	874 98 10-24	Screw Pan Head #10-24 x 1.50 Blk	41	532 16 96-83	Bracket Pnt Adj Pvt Bagger CRD
6	874 98 10-32	Screw Pan Hd	46	872 11 05-10	Bolt 5/16-18 x 1-1/4
7	873 40 10-00	Nut Wiz Lock Hex Serr/Hd 10-24	47	532 19 37-04	Tube Upper Bagger
8	532 18 10-95	Cover Bagger	49	532 19 33-05	Bar Spreader
9	872 14 04-18	Bolt Carriage 1/4-20 x 2.25d x Gr. 5	50	873 80 05-00	Nut 5/16-18
10	532 18 12-82	Tube Support Bagger CRD	51	532 19 99-03	Latch Spring Bagger
11	532 16 57-19	Bracket Support Upper Bag	53	873 51 04-00	Nut 1/4-20 unc
12	532 18 88-48	Bracket Pivot LH	54	872 14 04-06	Bolt 1/4-20 x 3/4 Gr. 5
13	874 76 06-12	Bolt Fin Hex 3/8-16 unc x 3/4	57	872 14 06-22	Bolt Rdhd Sqnk
14	874 52 06-36	Bolt Fin Hex 3/8-16 x 2-1/4 Gr. 5	59	532 43 04-22	Pin Clevis 0.375 x 2.375
15	532 12 46-70	Retainer Spring	60	532 00 49-29	Rivet Pan Hd Drilled 1/4
16	873 90 06-00	Nut Lock 3/8-16 unc	61	532 12 47-88	Retainer Spring 1"
17	872 14 05-06	Bolt Rdhd Sht Sqnk 5/16 -18 unc x 3/4	62	532 42 82-39	Actuator Elec
19	873 90 05-00	Nut Lock Hex Flange 5/16-18	63	532 42 82-38	Bracket Asm. Lower
20	532 18 88-47	Bracket Pivot RH	64	532 42 96-64	Bracket Mtg. Upper Left
21	532 40 61-80	Bag Asm CRD	65	532 42 96-65	Bracket Mtg. Upper Right
22	532 42 82-36	Bracket Side Bagger	66	532 43 04-24	Plug Bagger
24	532 16 57-83	Tube Pivot Bagger CRD	69	532 43 56-11	Washer .125
25	532 19 37-05	Tube Front Bagger	70	532 43 56-03	Rivet Pop .125 x .750
33	532 42 86-83	Plug Mulcher	71	532 43 83-13	Actuator Support Brkt.
34	532 16 55-70	Handle Mulcher			
35	532 16 55-72	Pin Mulcher			
36	819 13 20-12	Washer 13/32 x 1-1/4 x 12 Ga.			
37	532 17 54-01	Plug Support Bagger CRD			

NOTE: All component dimensions given in U.S. inches
1 inch = 25.4 mm

