

CT151

Spare parts

Ersatzteile

Pièces détachées

Reserve onderdelen

Repuestos

Reservdelar

ILLUSTRATED PARTS LIST

MFG. ID NO. 96061027400

CUSTOMER CATALOG NO. CT151

PRODUCT NO. 960 61 02-74

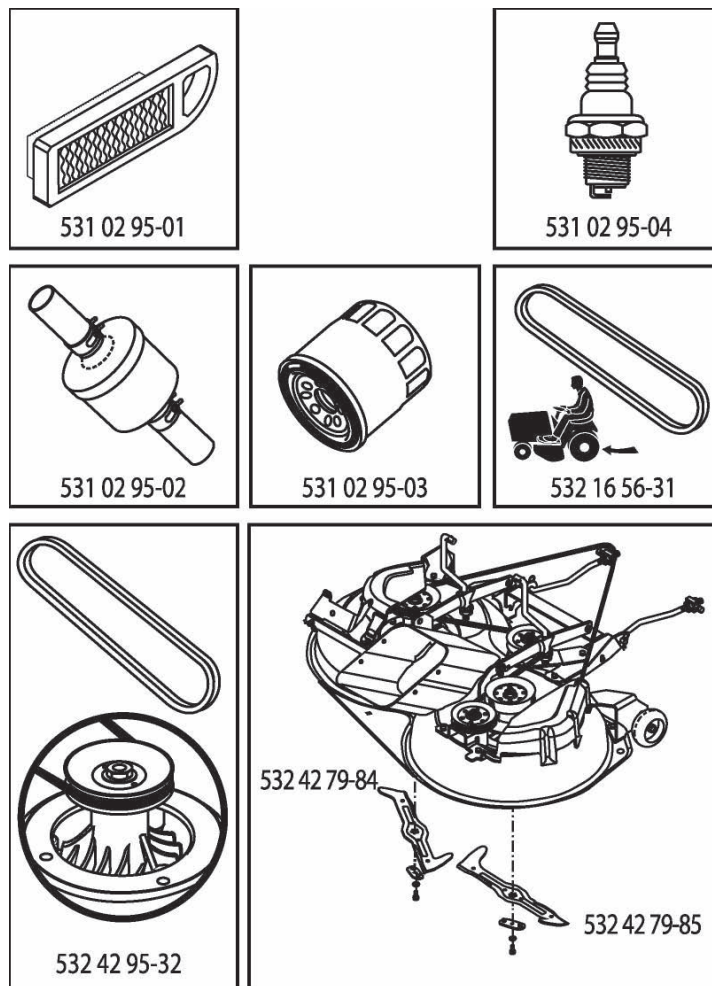

47

431135

**TRACTOR - - MODEL NO. CT151 (96061027400), PRODUCT NO. 960 61 02-74
DECALS 27**

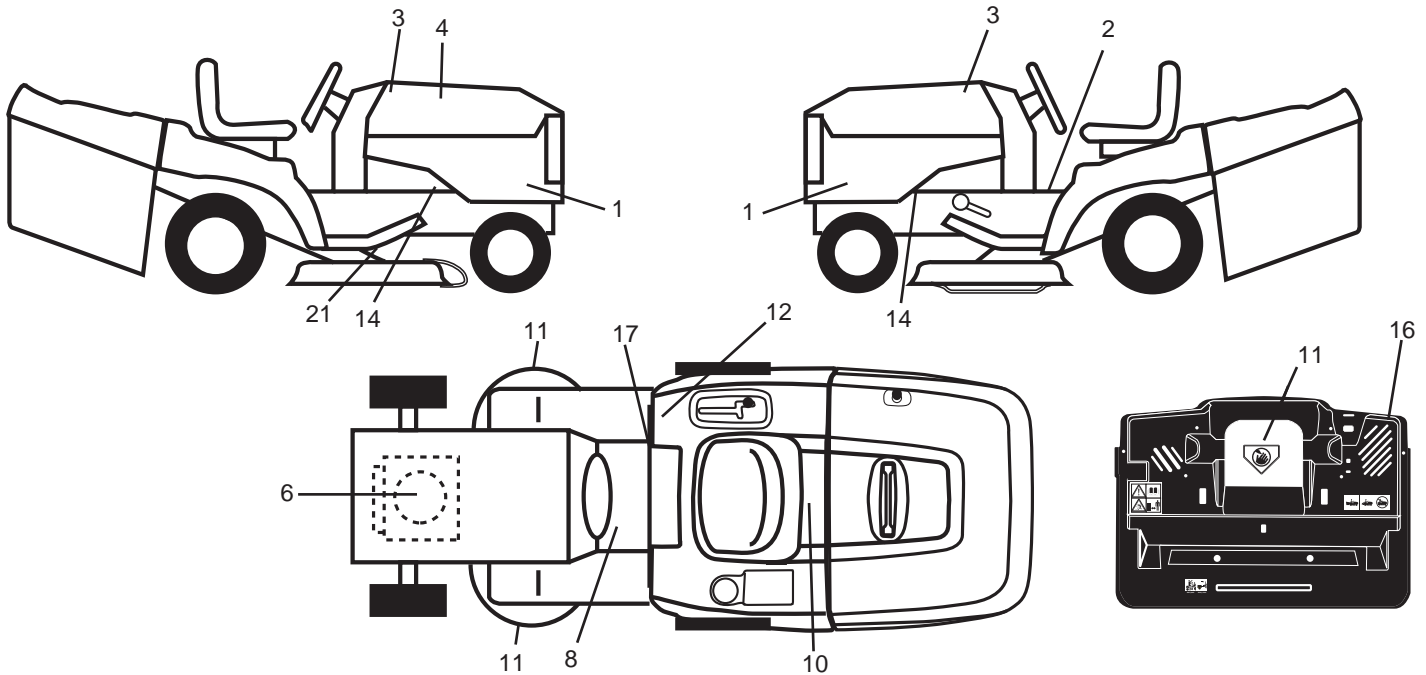

KEY NO.	PART NO.	DESCRIPTION
1	532 41 22-41	Decal Side Panel
2	532 40 03-89	Decal Warning Symbols CE
3	532 42 91-96	Enblem Hood
4	532 43 11-35	Decal Replacement
6	532 19 68-41	Decal Warning Engine Symbols
8	532 15 97-37	Decal Brake/Clutch Symbol
10	532 14 50-05	Decal Bat Dan/Poi P/L Sym Wpn
11	532 18 21-66	Decal Mower Cut Finger Symbol
12	532 18 04-32	Decal Fender 100 DB/CE
14	532 15 97-36	Decal Chassis Hot Muffler

KEY NO.	PART NO.	DESCRIPTION
16	532 18 04-35	Decal, Backplate CRD
17	532 14 08-37	Decal Saddle Brake Parking
21	532 16 62-86	Decal Deck Sch 92 CRD
--	532 13 83-11	Decal Lift Handle
--	532 18 19-16	Pad Footrest LH
--	532 18 19-17	Pad Footrest RH
--	532 43 09-70	Manual Operator's (Euro)
--	532 43 09-73	Manual Operator's (Scan)
--	532 43 09-76	Manual Operator's (EBloc)
--	532 43 09-78	Manual Operator's (Baltic)

WHEELS & TIRES

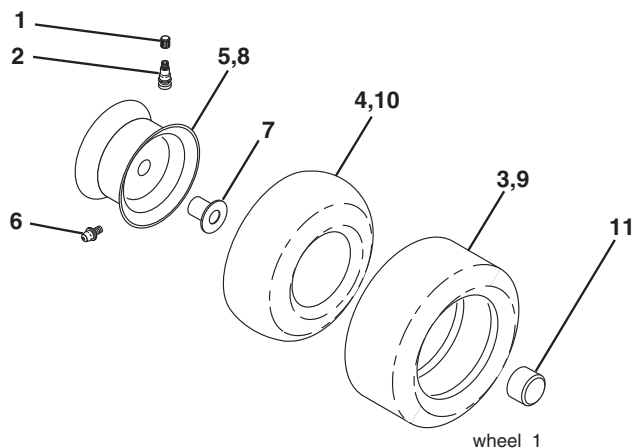

KEY NO.	PART NO.	DESCRIPTION
1	532 05 91-92	Cap Valve Tire
2	532 06 51-39	Stem Valve
3	532 10 62-22	Tire F Ts 15 x 6 0 - 6
4	532 05 99-04	Tube Inner Front #35060
5	532 13 83-36	Rim Asm 6" front
6	532 12 49-57	Fitting Grease
7	532 12 49-59	Bearing Flange
8	532 13 83-37	Rim Asm 8" rear
9	532 42 05-31	Tire Rear 18 x 9.5-8 "Turf Saver LT"
10	532 12 49-26	Tube Rear 9 5 x 8
11	532 17 50-39	Cap Axle Blk 1 50 x 1 00
--	532 14 43-34	Sealant, Tire (10 oz. tube)

NOTE: All component dimensions given in U.S. inches.
1 inch = 25.4 mm

**TRACTOR - - MODEL NO. CT151 (96061027400), PRODUCT NO. 960 61 02-74
SCHEMATIC 38**

SCH05

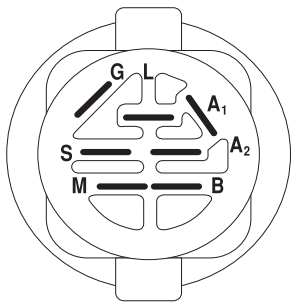
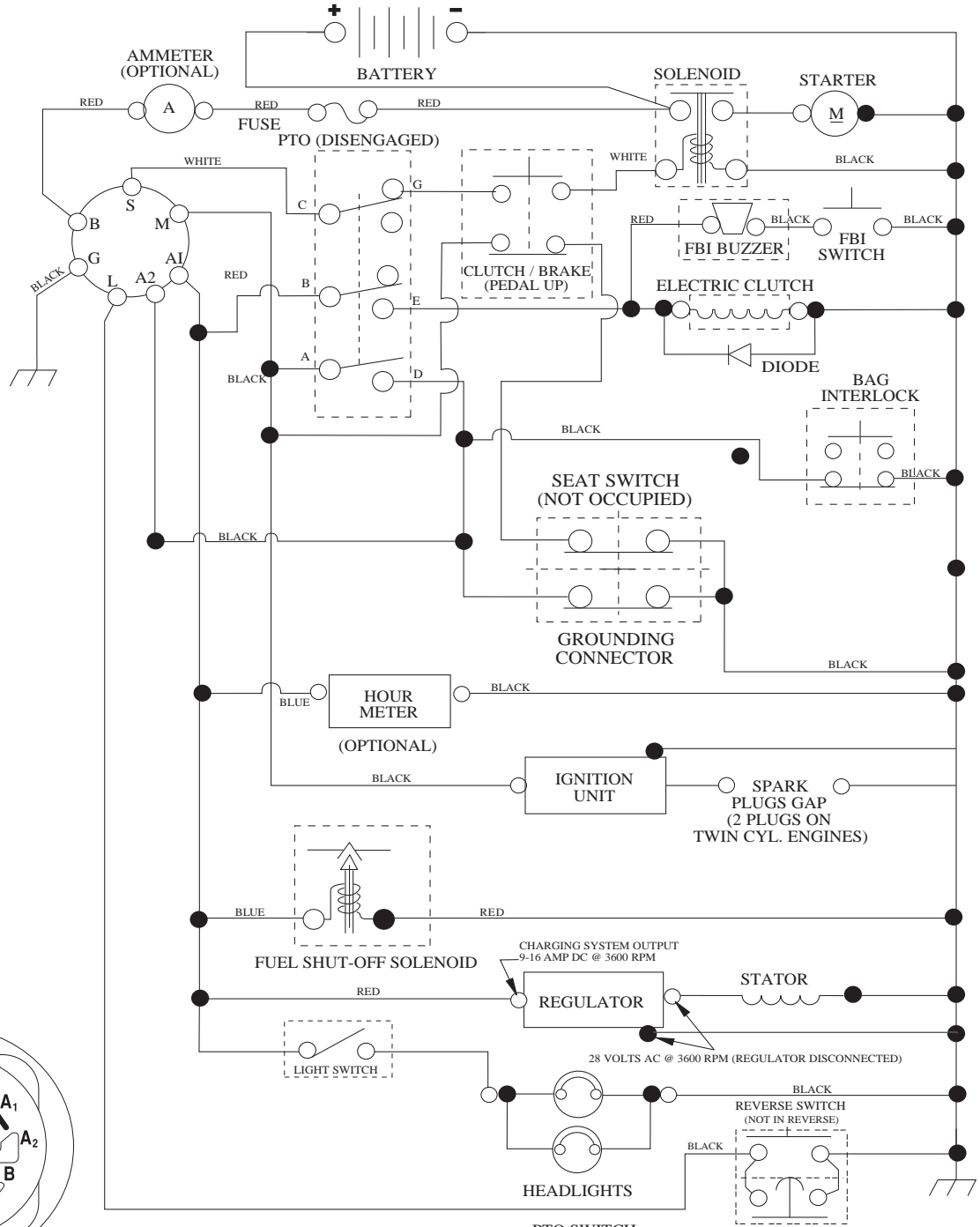

IGNITION SWITCH

POSITION	CIRCUIT "MAKE"
OFF	M+G+A1
RUN/OVERRIDE	B+A1
RUN	B+A1 L+A2
START	B + S + A1

WIRING INSULATED CLIPS
NOTE: IF WIRING INSULATED CLIPS WERE REMOVED FOR SERVICING OF UNIT, THEY SHOULD BE RE-INSTALLED TO PROPERLY SECURE YOUR WIRING.

03048

PTO SWITCH

POSITION	CIRCUIT
OFF	C + G, B + H
ON	C + F, B + E, A + D

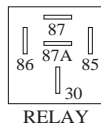

RELAY

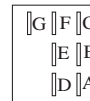

●
NON-REMOVABLE CONNECTIONS

○
REMOVABLE CONNECTIONS

TRACTOR - - MODEL NO. CT151 (96061027400), PRODUCT NO. 960 61 02-74
ELECTRICAL **32**

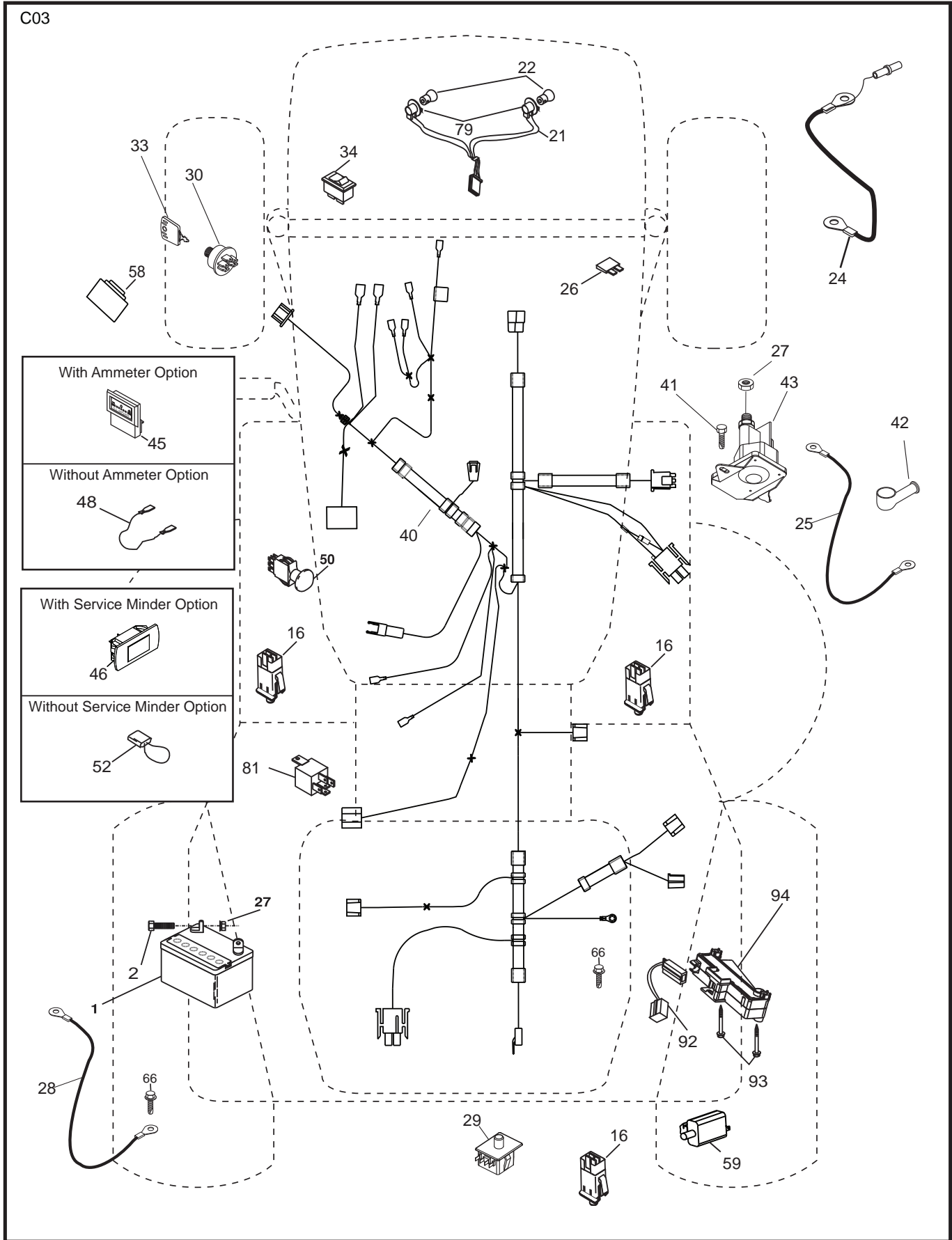

**TRACTOR - - MODEL NO. CT151 (96061027400), PRODUCT NO. 960 61 02-74
ELECTRICAL 32**

KEY NO.	PART NO.	DESCRIPTION
1	532 16 34-65	Battery
2	874 76 04-12	Bolt Hex Hd 1/4-20 unc x 3/4
16	532 17 61-38	Switch Interlock
21	532 40 02-52	Harness Asm Light w/4152J
22	532 00 41-52	Bulb Light #1156
24	532 42 12-99	Cable Starter 6 Ga. 11" Red
25	532 16 59-87	Cable Battery Crd 56" Red
26	532 17 51-58	Fuse
27	873 51 04-00	Nut Keps Hex 1/4-20 unc
28	532 12 77-25	Cable Ground 6 Ga. 18" Black
29	532 19 27-49	Switch Seat
30	532 19 33-50	Switch Ignition
33	532 41 19-35	Key/Chain
34	532 11 07-12	Switch Light
40	532 19 74-34	Harness Ign
41	871 11 04-08	Bolt Flk Fin Hex 1/4-20 unc x 1/2
42	532 13 15-63	Cover Terminal Red
43	532 19 25-07	Solenoid
48	532 14 08-44	Adapter Ammeter Rectangular
50	532 17 46-51	Switch PTO
52	532 14 19-40	Protection Wire Loop
58	532 16 94-19	Buzzer Crd
59	532 18 03-79	Switch FBI CRD
66	817 49 06-08	Screw Thdrol 3/8-16 x 1/2 Ty-Tt
79	532 17 52-52	Socket Asm Bulb
81	532 10 97-48	Relay Asm
92	532 19 66-15	Harness Pigtail
93	532 19 25-40	Screw Plastite 10-14 x 2.0
94	532 19 18-34	Module Reverse

NOTE: All component dimensions given in U.S. inches.
1 inch = 25.4 mm.

TRACTOR - - MODEL NO. CT151 (96061027400), PRODUCT NO. 960 61 02-74
CHASSIS AND ENCLOSURES **39**

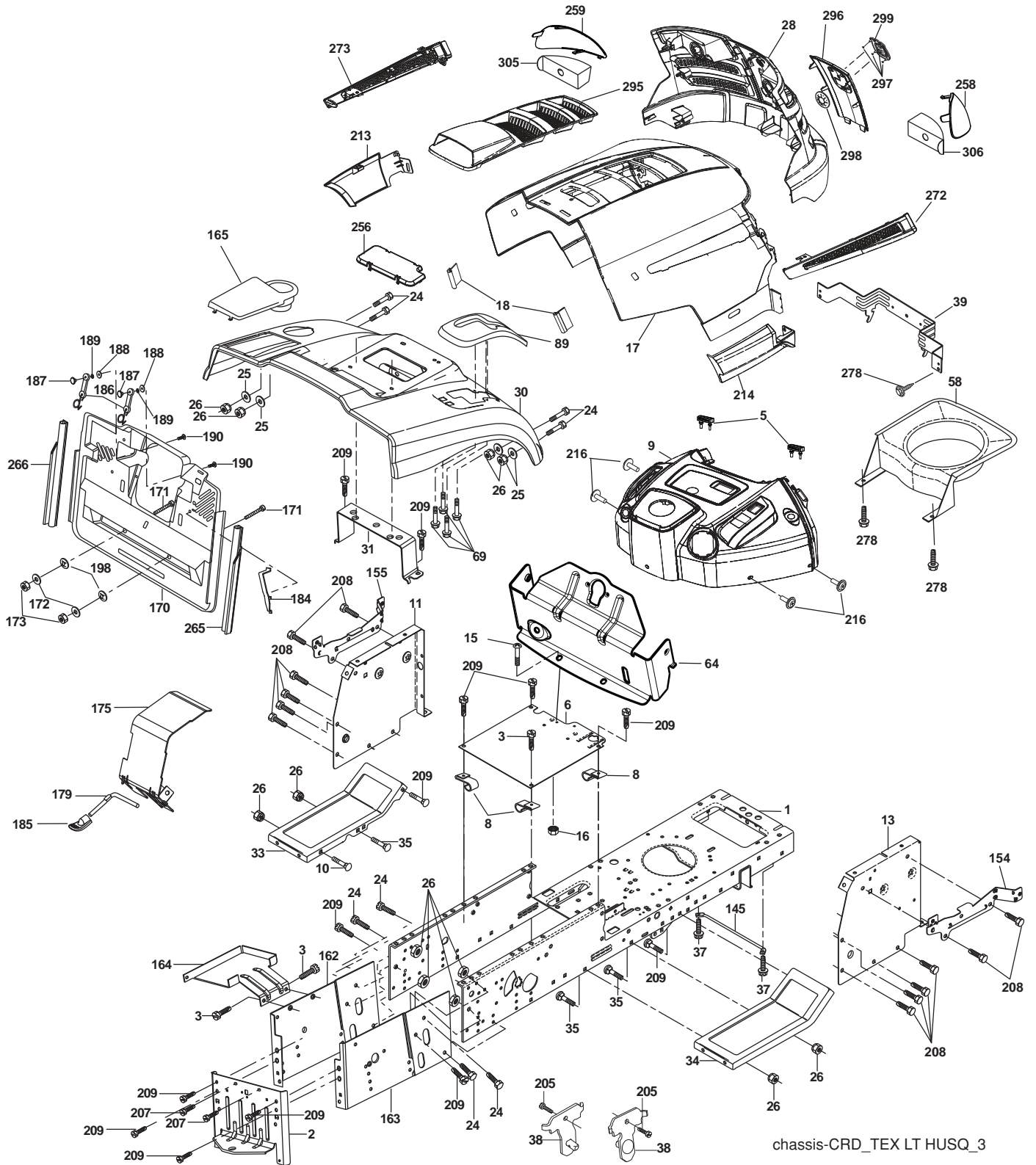

chassis-CRD_TEX LT HUSQ_3

**TRACTOR - - MODEL NO. CT151 (96061027400), PRODUCT NO. 960 61 02-74
CHASSIS AND ENCLOSURES 39**

KEY NO.	PART NO.	DESCRIPTION	KEY NO.	PART NO.	DESCRIPTION
1	532 17 46-20	Chassis	173	873 51 06-00	Nut, Keps Hex 3/8-16 unc
2	532 18 03-84	Drawbar	175	532 18 82-03	Door Trap
3	817 06 06-12	Screw 3/8-16 x 3/4	179	532 18 82-02	Rod Pivot FBI CRD
5	532 40 75-90	Bumper Hood/Dash	184	532 17 46-62	Bracket Actuator Bagger CRD
6	532 18 44-19	Saddle	185	532 18 11-01	Knob Rod Brake Parking
8	532 12 64-71	Clip Insulator 13/32 Mtg. Hole	186	532 16 07-93	Latch Asm Mulch/Bagger
9	532 40 94-67	Dash	187	532 12 50-04	Nut Weld
10	872 14 06-08	Bolt, Carriage 3/8-16 x 3/4	188	819 06 12-16	Washer #10
11	532 17 49-96	Panel, Dash LH	189	810 07 10-00	Washer Lock #10
13	532 17 21-06	Panel, Dash RH	190	871 08 10-10	Screw Pan Hd Phillip 10-24 x 5/8
15	874 18 05-12	Screw, Machine, Truss Head 5/16-18 unc x 3/4	198	532 16 89-37	Nut, Push
16	873 51 05-00	Nut	205	817 49 06-08	Screw Thdrol 3/8-16 x 1/2
17	532 44 12-67	Hood	207	817 67 05-08	Screw Thdrl. 5/16-18 x 1/2
18	532 40 47-42	Bumper Hood	208	817 67 06-08	Screw Thdrol 3/8-16 x 1/2
24	874 78 06-16	Bolt	209	817 00 06-12	Screw Hex Wsh Thdrol 3/8-16
25	819 13 13-12	Washer 13/32 x 13/16 x 12 Ga.	213	532 41 10-77	Skirt Side LH
26	873 80 06-00	Nut	214	532 41 10-76	Skirt Side RH
28	532 42 69-63	Grille	216	817 67 04-12	Screw 1/4-20 x 3/4
30	532 44 12-65	Fender	256	532 18 13-61	Cover Fender Rack
31	532 16 51-56	Bracket, Fender Support	258	532 41 10-78	Lens RH
33	532 18 10-57	Footrest, LH	259	532 41 10-79	Lens LH
34	532 18 10-58	Footrest, RH	265	532 18 57-04	Seal RH Side Bagger
35	872 11 06-06	Bolt 3/8-16 x 3/4	266	532 18 57-03	Seal LH Side Bagger
37	817 49 05-08	Screw Thdrol 5/16-18 x 1/2 TYT	272	532 41 10-75	Vent Hood RH
38	532 18 17-48	Bracket Asm Pivot Mower Rear	273	532 41 10-74	Vent Hood LH
39	532 40 78-07	Bracket Pivot	278	532 41 63-58	Screw 10 x .750 BOS Thread
58	532 40 75-37	Duct Air Engine	295	532 41 11-16	Vent Top Hood
64	532 40 81-27	Dash Lower	296	532 41 11-19	Trim
69	532 14 24-32	Screw HxWsh Hi-Lo	297	532 19 91-45	Clip Retainer Tinner
89	532 19 74-07	Console CRD 6 Sp. 418	298	532 11 04-52	Nut Push
145	532 40 91-67	Rod Pivot Chassis/Hood	299	532 40 50-12	Logo
154	532 40 81-22	Bracket Dash RH	305	532 40 66-65	Insert Reflective LH
155	532 40 81-23	Bracket Dash LH	306	532 41 65-00	Insert Reflective RH
162	532 18 03-82	Bracket Exten Chassis LH CRD	--	532 41 11-15	Plug Dash
163	532 18 03-83	Bracket Exten Chassis RH CRD			
164	532 16 56-05	Support Battery CRD			
165	532 18 11-00	Cover Battery			
170	532 19 94-88	Backplate CRD			
171	872 14 06-20	Bolt Rdhd Sqnk 3/8-16 x 2-1/2 Gr. 5			
172	819 13 20-16	Washer 13/32 x 1-1/4 x 16 Ga.			

NOTE: All component dimensions given in U.S. inches.
1 inch = 25.4 mm.

TRACTOR - - MODEL NO. CT151 (96061027400), PRODUCT NO. 960 61 02-74
DRIVE **40**

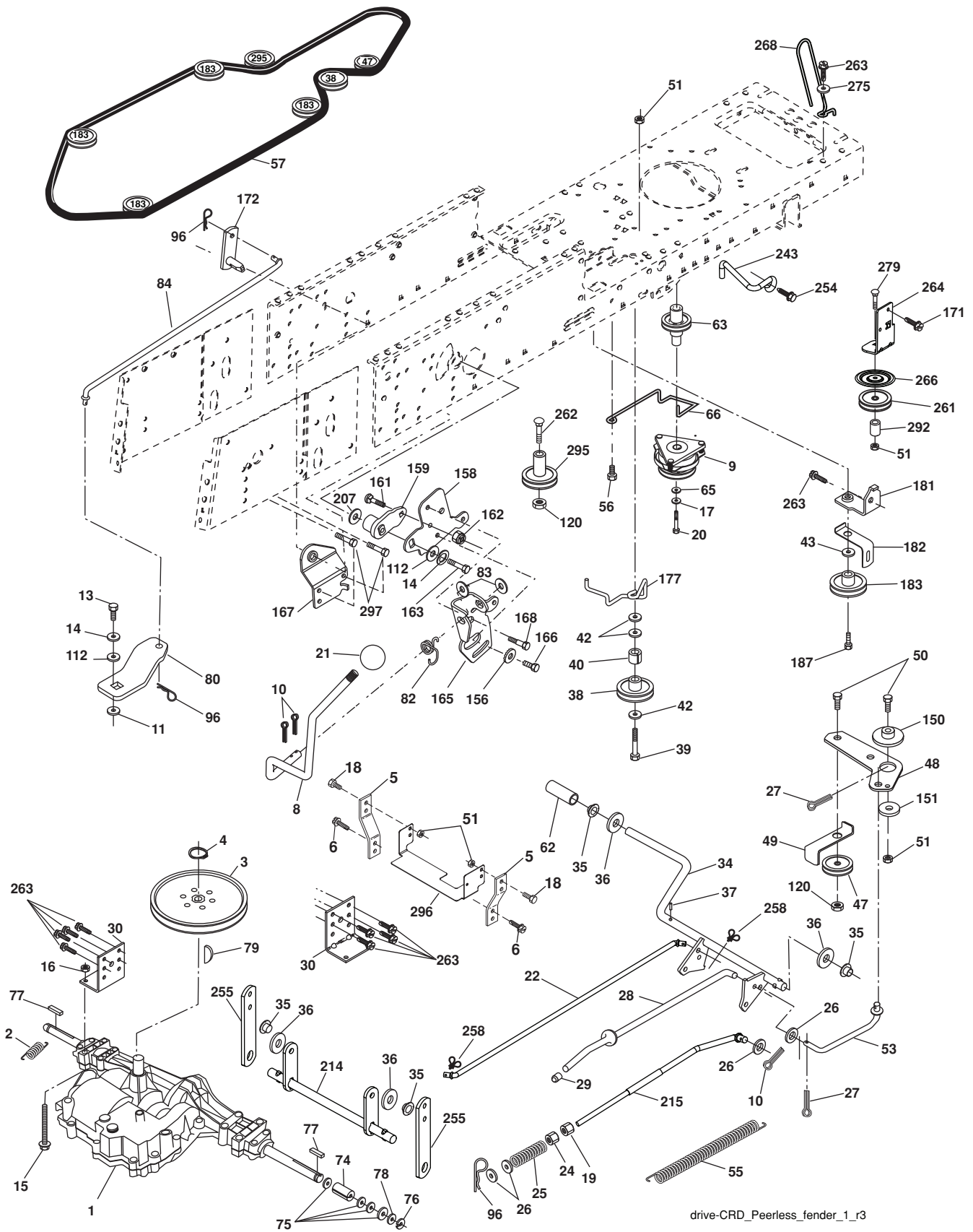

drive-CRD_Peerless_fender_1_r3

**TRACTOR - - MODEL NO. CT151 (96061027400), PRODUCT NO. 960 61 02-74
DRIVE **40****

KEY NO.	PART NO.	DESCRIPTION	KEY NO.	PART NO.	DESCRIPTION
1	-----	Transaxle Peerless 206-546	77	532 12 35-83	Key, Square
2	532 14 66-82	Spring Brake Return	78	532 12 17-48	Washer 25/32 x 1-5/8 x 16 Ga.
3	532 16 59-99	Pulley Transaxle	79	532 12 50-96	Key Woodruff
4	812 00 00-28	Ring Retainer #5100-62	80	532 14 50-90	Arm Shift PMST 20" Tires
5	532 12 15-20	Strap torque 30 degrees	82	532 16 57-11	Spring, Torsion
6	817 06 05-12	Screw 5/16-18 x 3/4	83	819 17 12-16	Washer 17/32 x 3/4 x 16 Ga.
8	532 19 27-06	Rod Shift	84	532 16 56-21	Link Shift CRD Pmst 18" Tires
9	532 19 81-43	Clutch Ogura	96	532 12 47-88	Spring, Retainer 1"
10	876 02 04-16	Pin, Cotter 1/8 x 1	112	819 09 12-10	Washer 9/32 x 3/4 x 10 Ga.
11	532 10 57-01	Washer Plate Shf .3888 sq hole	120	873 90 06-00	Nut Lock Flg. 3/8-16 unc
13	874 55 04-12	Bolt 1/4-28 unf Gr. 8 w/patch	150	532 16 58-50	Bushing, Bellcrank Grnd Dr
14	810 04 04-00	Washer, Lock Hvy Helical	151	819 13 32-10	Washer 13/32 x 2 x 10 Ga.
15	874 49 05-44	Bolt Hex Flghd 5/16-18 Gr. 5	156	532 16 60-02	Washer Srrd 5/16 ID x 1.125
16	873 80 05-00	Nut, Lock Hex w/Ins 5/16-18 unc	158	532 16 55-89	Bracket Shift Mount
17	532 12 61-97	Washer 1-1/2 ODX 15/32 ID x .250	159	532 18 39-00	Hub Shift
18	874 78 06-16	Bolt Hex 3/8-16 unc x 1 Gr. 5	161	872 14 04-06	Bolt Rdhd Sqnk 1/4-20 x 3/4 Gr. 5
19	873 80 06-00	Nut, Lock Hex w/Wsh 3/8-16 unc	162	873 68 04-00	Nut Crownlock 1/4-20 unc
20	532 17 39-37	Bolt Hex 7/16-20 x 4 x GR5-1.5	163	874 78 04-16	Bolt Hex Fin 1/4-20 unc x 1 Gr. 5
21	532 12 12-74	Knob Duckhead	165	532 16 56-23	Bracket Pivot Lever
22	532 17 56-07	Rod, Brake CRD	166	817 49 05-10	Screw 5/16-18 x 5/8
24	873 35 06-00	Nut	167	532 16 55-88	Bracket Support Shift CRD
25	532 10 68-88	Spring, Rod, Brake	168	532 16 54-92	Bolt Shoulder 5/16-18 x .561
26	819 13 13-16	Washer 13/32 x 13/16 x 16 Ga.	171	817 49 06-08	Screw Thdrol 3/8-16 x 1/2 Ty-Tt
27	876 02 04-12	Pin, Cotter 1/8 x 3/4	172	532 16 56-35	Shaft Asm Shift Front CRD PMST
28	532 17 57-65	Rod, Parking Brake	177	532 16 59-32	Keeper Flat Idler 3.06" CRD
29	532 12 42-36	Cap Brake Parking	181	532 18 02-11	Bracket Idler Ground Drive CRD
30	532 17 49-73	Bracket, Mfg. Transaxle	182	532 18 26-82	Keeper Belt 2.5" Od V-Idler CRD
34	532 17 55-78	Shaft, Asm Pedal Foot	183	532 19 95-34	Pulley V-Idler
35	532 12 01-83	Bearing, Nylon	187	817 58 05-20	Screw 5/16-18 x 1.25
36	819 21 16-16	Washer 21/32 x 1 x 16 Ga.	207	532 16 98-45	Washer Nylon Rear
37	532 12 49-63	Pin, Roll 3/16 x 1"	214	532 17 56-09	Shaft Asm Blade
38	532 16 59-36	Pulley, Flat	215	532 41 01-42	Rod Brake
39	874 76 06-44	Bolt Fin Hex 3/8-16 unc x 2-3/4	243	532 19 07-36	Bracket Anti-Rotation
40	532 12 49-65	Spacer, Split 395 x 59 Bzp	254	817 00 06-16	Screw 3/8-16 x 1
42	819 13 13-12	Washer 13/32 x 13/16 x 12 Ga.	255	532 17 56-08	Brace Shaft Brake Mtg.
43	819 11 10-12	Washer 11/32 x 5/8 x 12 Ga.	258	532 17 80-62	Clip Retainer
47	532 12 77-83	Pulley, Idler, V Groove Plastic	261	532 13 14-94	Pulley Idler
48	532 15 44-07	Bellcrank Clutch Grnd Drv	263	817 00 06-12	Screw 3/8-16 x 3/4
49	532 12 32-05	Retainer, Belt Style Spring	262	872 11 06-22	Bolt Rdhd 3/8-16 unc x 2-3/4 Gr. 5
50	872 11 06-12	Bolt 3/8-16 unc x 1-1/2	264	532 43 11-72	Bracket Idler Chass.
51	873 68 06-00	Nut, Crownlock 3/8-16 unc	266	532 18 20-61	Shield Idler Mower
53	532 19 96-52	Link, Clutch 7.66	268	532 18 24-02	Guard Muffler RH
55	532 10 57-09	Spring, Return, Clutch	275	819 13 16-14	Washer 13/32 x 1 x 14 Ga.
56	817 06 06-20	Screw 3/8-16 x 1-1/4	279	872 11 06-16	Bolt 3/8-16 unc x 2
57	532 16 56-31	V-Belt Kev PMST CRD	292	532 40 02-71	Spacer
62	532 12 48-72	Cover, Pedal	295	532 17 91-14	Pulley Idler
63	532 18 03-97	Pulley Engine	297	817 49 06-10	Screw HXWSH THDR 3/8-16 x 5/8
65	810 04 07-00	Washer			
66	532 15 47-78	Keeper, Belt Engine F-Proof			
74	532 13 70-57	Spacer Axle			
75	532 12 17-49	Washer 25/32 x 1-1/4 x 16 Ga.			
76	812 00 00-01	Ring, E			

NOTE: All component dimensions given in U.S. inches
1 inch = 25.4 mm

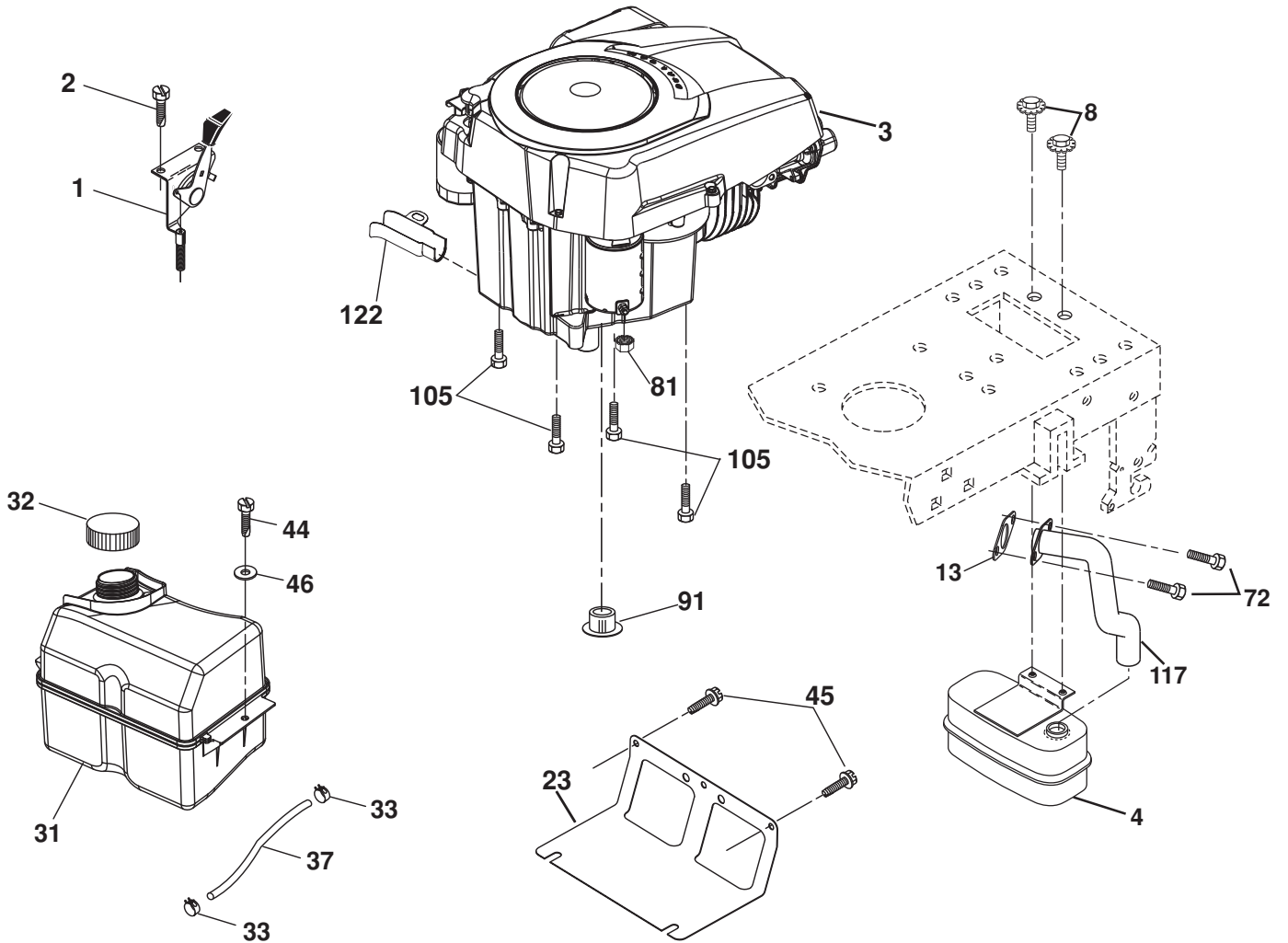

29
OPTIONAL EQUIPMENT
Spark Arrester

engine-CRD_Kohl_8

**TRACTOR - - MODEL NO. CT151 (96061027400), PRODUCT NO. 960 61 02-74
ENGINE 24**

KEY NO.	PART NO.	DESCRIPTION
1	532 18 38-97	Control Throt /Ch Flag
2	532 41 63-58	Screw 10 x .750
3	-----	Engine Kohler SV470-0212
4	532 18 86-55	Muffler Exhaust
8	532 17 18-77	Bolt 5/16-18 x 3/4
13	532 18 59-09	Gasket
23	532 16 98-37	Shield Browning/Debris Guard
29	532 13 71-80	Arrestor Spark
31	532 40 75-45	Tank Fuel
32	532 42 51-62	Cap Fuel
33	532 12 34-87	Clamp Hose Blk
37	532 13 70-40	Line Fuel 20"
44	817 67 04-12	Screw Hexwsh Thdrol 1/4-20 x 3/4
45	817 00 06-12	Screw Hexwsh Thdr 3/8-16 x 3/4
46	819 09 14-16	Washer 9/32 x 7/8 x 16ga
72	532 19 23-34	Screw 5/16-18 x .75
81	873 51 04-00	Nut Keps 1/4-20 unc
91	532 18 74-95	Bushing 1.375 OD
105	817 12 06-16	Screw 3/8-16 x 1
117	532 18 86-54	Tube Exhaust
122	532 42 19-22	Extension Drain Oil

NOTE: All component dimensions given in U.S. inches.
1 inch = 25.4 mm

TRACTOR - - MODEL NO. CT151 (96061027400), PRODUCT NO. 960 61 02-74
 STEERING ASSEMBLY **41**

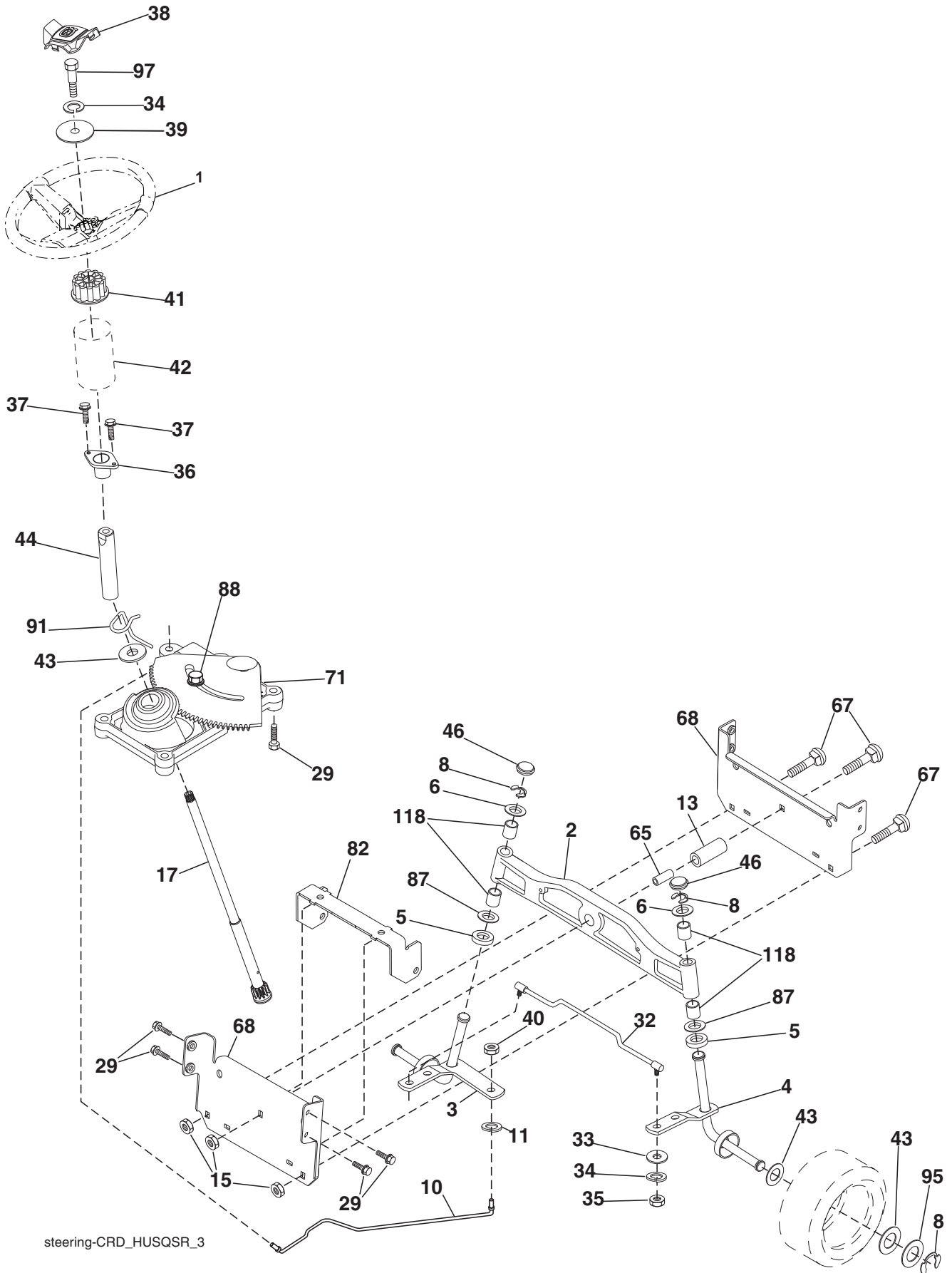

steering-CRD_HUSQSR_3

**TRACTOR - - MODEL NO. CT151 (96061027400), PRODUCT NO. 960 61 02-74
STEERING ASSEMBLY 41**

KEY NO.	PART NO.	DESCRIPTION
1	532 41 64-80	Steering Wheel
2	532 19 35-42	Axle Asm Cast Iron Lt
3	532 16 98-40	Spindle Assembly, LH
4	532 16 98-39	Spindle Assembly, RH
5	532 12 49-31	Bearing, Race, Thrust, Hardened
6	532 12 17-48	Washer 25/32 x 1-5/8 x 16 Ga.
8	812 00 00-29	Ring, Klip
10	532 17 51-21	Link, Drag
11	810 04 06-00	Washer, Lock
13	532 13 65-18	Spacer Brg Axle Front
15	532 14 52-12	Nut Hex Flange Lock
17	532 19 07-53	Shaft, Steering
29	817 00 06-12	Screw 3/8-16 x 3/4
32	532 17 18-88	Rod, Tie
33	819 11 12-16	Washer 11/32 x 3/4 x 16 Ga.
34	810 04 05-00	Washer Lock Hvy Hlcl Spr 5/16
35	873 54 05-00	Crownlock Nut 5/16-24 unf 3847
36	532 15 50-99	Bushing, Steering
37	532 15 29-27	Screw TT #10-32 x 5 x 3/8 Flange
38	532 41 59-87	Cap Wheel Steering
39	819 11 38-12	Washer 11/32 ID x 2- 3/8 OD x 12 Ga.
40	873 54 06-00	Nut Crownlock 3/8-24
41	532 18 67-37	Adaptor, Steering Wheel
42	532 41 11-39	Boot, Steering Dash
43	532 12 17-49	Washer 25/32 x 1-1/4 x 16 Ga.
44	532 19 07-52	Extension Steering Shaft
46	532 12 12-32	Cap, Spindle
65	532 41 47-36	Spacer Brace Axle
67	872 11 06-18	Bolt Rdhd Sqnk 3/8-16 x 2-1/4
68	532 16 98-27	Brace Axle
71	532 17 51-46	Steering Asm.
82	532 19 99-78	Bracket Susp Chassis Front
87	532 17 39-66	Washer Flat .781 x 1 1/2 x .14
88	532 17 51-18	Bolt Shoulder 7/16-20 unc
91	532 17 55-53	Clip Steering
95	532 18 89-67	Washer
97	532 42 89-82	Bolt Fin HX 5/16-18 x 4 w/Patch
118	532 40 60-13	Bushing

NOTE: All component dimensions given in U.S. inches.
1 inch = 25.4 mm.

TRACTOR - - MODEL NO. CT151 (96061027400), PRODUCT NO. 960 61 02-74
MOWER DECK **44**

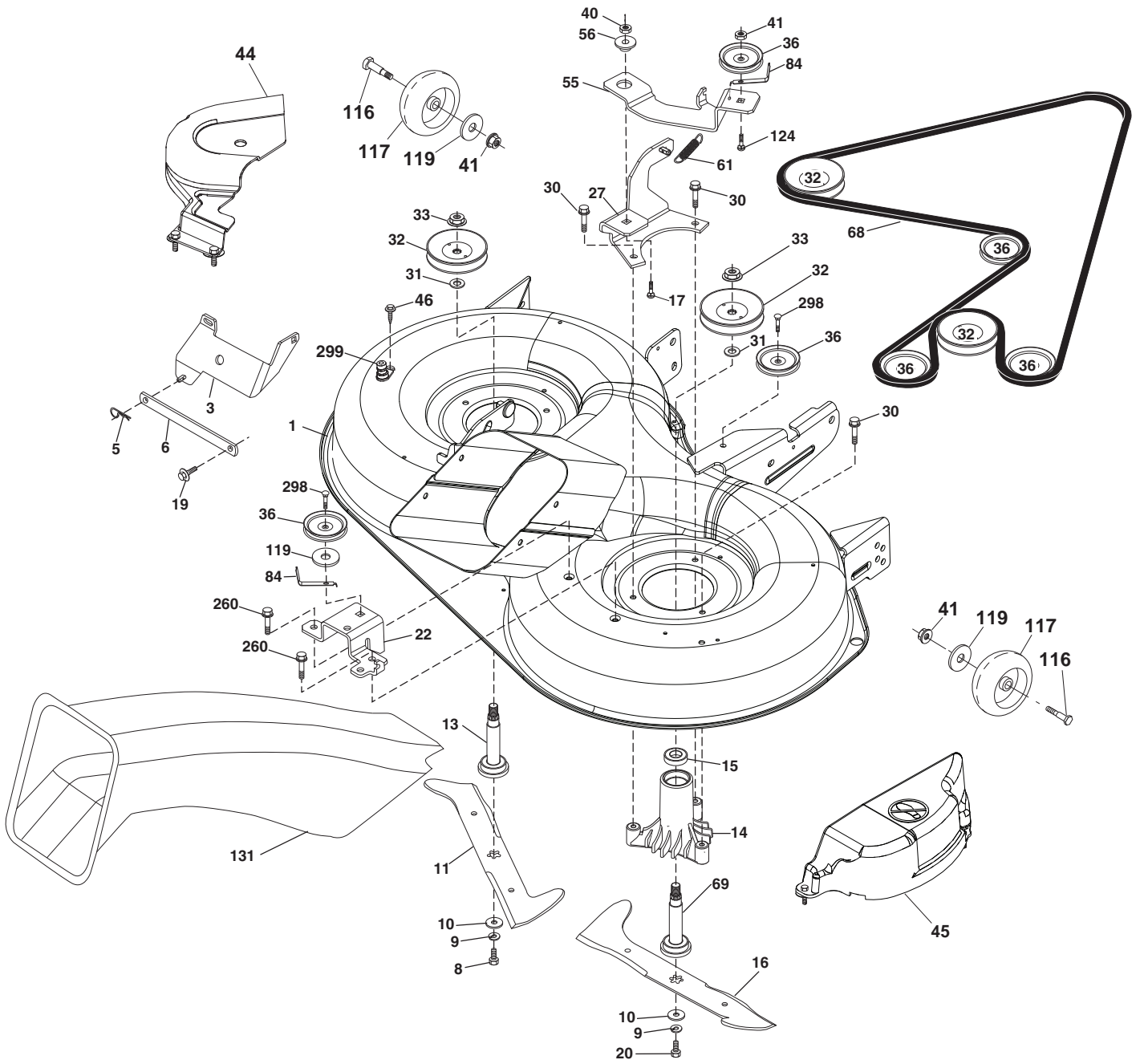

Deck-CRD_97cm_Elect_1_r5

**TRACTOR - - MODEL NO. CT151 (96061027400), PRODUCT NO. 960 61 02-74
MOWER DECK 44**

KEY NO.	PART NO.	DESCRIPTION
1	532 42 91-21	Housing Asm. Mower 97 CRD
3	532 43 18-64	Bracket Asm. S-Bar Chass 97 CRD
5	532 43 18-64	Retainer Spring
6	532 16 55-57	Bar Sway 97 CRD
8	532 18 17-12	Bolt 3/8-24 x 1.25 Gr. 8 Patched
9	810 03 06-00	Washer Lock Hvy 3/8 Unplated
10	532 14 02-96	Washer Hard
11	532 42 79-84	Blade 3-1 LH 97 CRD
13	532 13 76-45	Shaft Asm. w/Lower Bearing
14	532 12 87-74	Housing Mandrel Vented (Machd)
15	532 11 04-85	Bearing Ball Mandrel
16	532 42 79-85	Blade 3-1 RH 97 CRD
17	872 14 06-10	Bolt Carriage 3/8-16 x 1-1/4
19	532 13 28-27	Bolt Shoulder 5/16-18 Thd Form
20	532 18 17-13	Bolt 3/8-24 x 1.25 Gr. 8 Ptch Lhthd
22	532 43 11-69	Bracket Idler Sprt 97 CRD
27	532 42 79-81	Bracket Asm. Susp. Rear RH
30	532 17 39-84	Screw Thd Rolling
31	532 18 76-90	Washer Spacer Mower Vented
32	532 15 35-32	Mandrel Pulleys
33	532 40 02-34	Nut Flg Top Lock
36	532 14 67-63	Pulley Idler V-Groove Dim 4.25
40	873 68 06-00	Nut Crownlock 3/8-16 unc
41	873 90 06-00	Nut Lock Flg. 3/8-16 unc
44	532 43 49-46	Cover Mandrel LH 97 CRD
45	532 44 14-79	Cover Mandrel RH 97 CRD
46	532 13 77-29	Screw Thdrl. 1/4-20 x 5/8
55	532 19 94-98	Arm Idler 97 CRD
56	532 16 57-23	Spacer Retainer Mower
61	532 19 94-86	Spring Tension Belt
68	532 42 95-32	Belt Drive 97 Mower
69	532 16 54-82	Shaft Asm w/Lwr Brg RH Thd CRD
84	532 15 60-85	Keeper Belt Idler
116	532 19 34-06	Bolt Shoulder
117	532 17 48-73	Wheel Gage
119	819 13 20-12	Washer 13/32 x 1-1/4 x 12 GA.
124	872 11 06-12	Bolt Carr Sh 3/8-16 x 1-1/2 Gr. 5
131	532 16 56-61	Chute Bagger CRD 97cm
260	817 67 06-08	Screw Thdrol 3/8-16 x 1/2
298	817 49 06-28	Screw Thdrol 3/8-16 x 1-3/4
299	532 41 55-98	Port Washout
--	532 18 18-57	Mandrel Assembly (Includes hous- ing, shaft assembly, and bear- ing only - pulley/nut/washer and blade bolt/washers not included)
--	532 18 18-58	Mandrel Asm CRDLH Threads SVC
--	532 43 34-84	Replacement Mower, Complete (Std. Deck - Order separately guage wheel components key nos. 116, 117 & 119)

NOTE: All component dimensions given in U.S. inches
1 inch = 25.4 mm

TRACTOR - - MODEL NO. CT151 (96061027400), PRODUCT NO. 960 61 02-74
 MOWER LIFT **45**

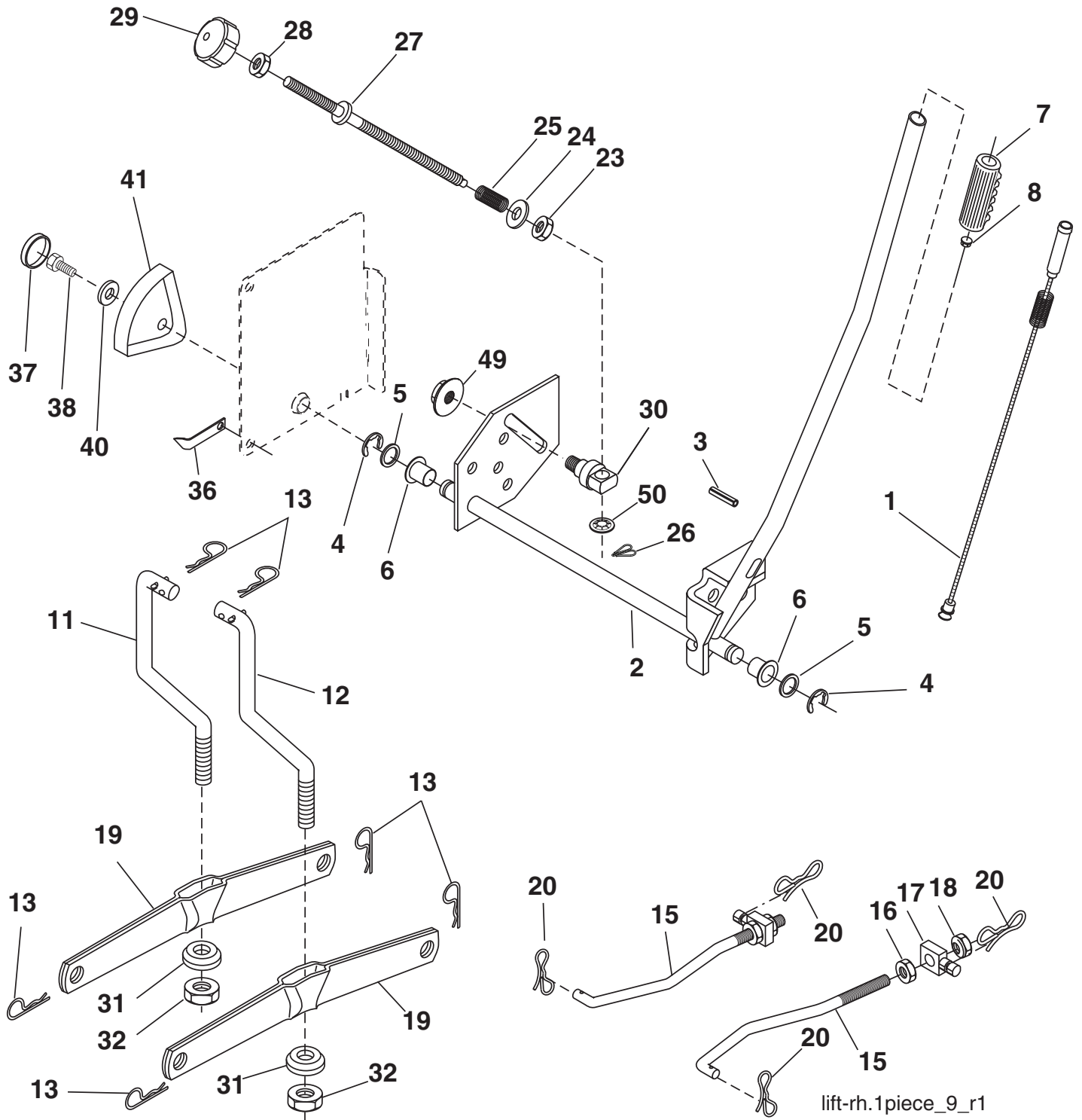

**TRACTOR - - MODEL NO. CT151 (96061027400), PRODUCT NO. 960 61 02-74
MOWER LIFT 45**

KEY NO.	PART NO.	DESCRIPTION
1	532 40 49-81	Plunger Asm.
2	532 15 94-71	Shaft Asm. Lift
3	532 10 57-67	Pin Groove
4	812 00 00-02	E Ring #5133-62
5	819 21 16-21	Washer 21/32 x 1 x 21 Ga.
6	532 12 01-83	Bearing Nylon
7	532 12 56-31	Grip Handle
8	532 12 23-65	Button Plunger Black
11	532 13 98-65	Link Lift LH
12	532 13 98-66	Link Lift RH
13	532 12 46-70	Retainer Spring
15	532 17 32-88	Link Front
16	873 35 08-00	Nut Jam Hex 1/2-13 unc
17	532 17 56-89	Trunnion
18	873 80 08-00	Nut Lock w/Wsh 1/2-13 unc
19	532 13 98-68	Arm Suspension Mower
20	532 19 42-09	Pin Cotter 7/16 Bow Tie Lock
23	532 11 08-07	Nut Special
24	819 13 10-16	Washer 13/32 x 5/8 x 16 Ga.
25	532 16 40-24	Spring Comp
26	532 16 94-84	Retainer Clip
27	532 16 45-43	Rod Adj Lift Zinc
28	873 35 06-00	Nut Hex Jam 3/8-16 unc
29	532 13 80-57	Knob Inf 3/8-16 unc
30	532 15 02-33	Trunnion Infin Height
31	532 16 98-65	Bearing, Pvt. Lift.
32	873 54 06-00	Nut Crownlock 3/8-24
36	532 15 50-97	Pointer Height Indicator
37	532 12 39-35	Plug Hole Blk
38	817 06 05-16	Screw 5/16-18 x 1
40	819 11 24-10	Washer 11/32 x 1-1/2 x 10 Ga.
41	532 12 39-34	Scale Ind Height Blk
49	532 14 52-12	Nut Hex Flange Lock
50	532 11 04-52	Nut Push Phos & Oil

NOTE: All component dimensions given in U.S. inches.
1 inch = 25.4 mm

**TRACTOR - - MODEL NO. CT151 (96061027400), PRODUCT NO. 960 61 02-74
SEAT ASSEMBLY 42**

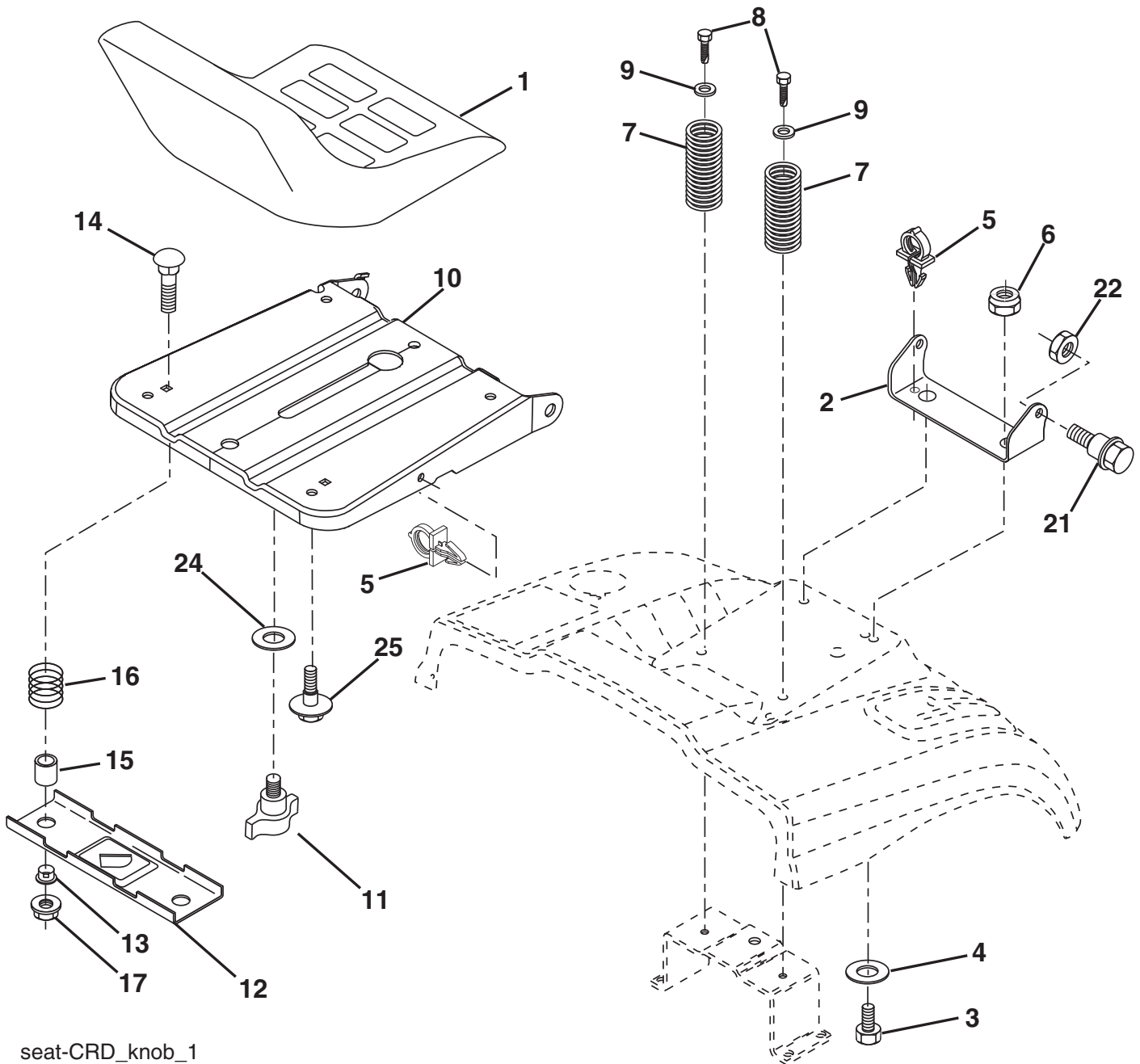

KEY NO.	PART NO.	DESCRIPTION
1	532 19 01-20	Seat
2	532 14 05-51	Bracket Pnt Pivot Seat (blk)
3	871 11 06-16	Bolt Fin Hex 3/8-16 x 1
4	819 13 16-10	Washer Flat 13/32 x 1 x 10 Ga.
5	532 14 50-06	Clip Push In Hinged
6	873 80 06-00	Nut Lock Hx w/Ins. 3/8-16
7	532 12 41-81	Spring Seat Cprsn 2 250 Blk Zi
8	817 00 06-16	Screw 3/8-16 x 1-1/2
9	819 13 16-14	Washer 13/32 x 1 x 14 Ga.
10	532 19 55-30	Pan Pnt Seat
11	532 16 63-69	Knob Seat Adj. Wingnut
12	532 17 46-48	Bracket Pnt Mounting Switch

KEY NO.	PART NO.	DESCRIPTION
13	532 12 12-48	Bushing Snap Blk Nyl 50 Id
14	872 05 04-12	Bolt Rdhd Sht Nk 1/4-20 x 1-1/2
15	532 13 43-00	Spacer Split
16	532 12 12-50	Spring Cprsn Plate SW 1.310 Ga.
17	532 12 39-76	Nut Lock 1/4 Lge Flg Gr 5 Zinc
21	532 17 18-52	Bolt Shoulder 5/16-18 unc-2A
22	873 80 05-00	Nut Hex Lock w/Ins 5/16-18
24	819 17 19-12	Washer 17/32 x 1-3/16 x 12 Ga.
25	532 12 70-18	Bolt Shoulder 5/16-18 x 62

NOTE: All component dimensions given in U.S. inches.
1 inch = 25.4 mm

**TRACTOR - - MODEL NO. CT151 (96061027400), PRODUCT NO. 960 61 02-74
BAGGER 46**

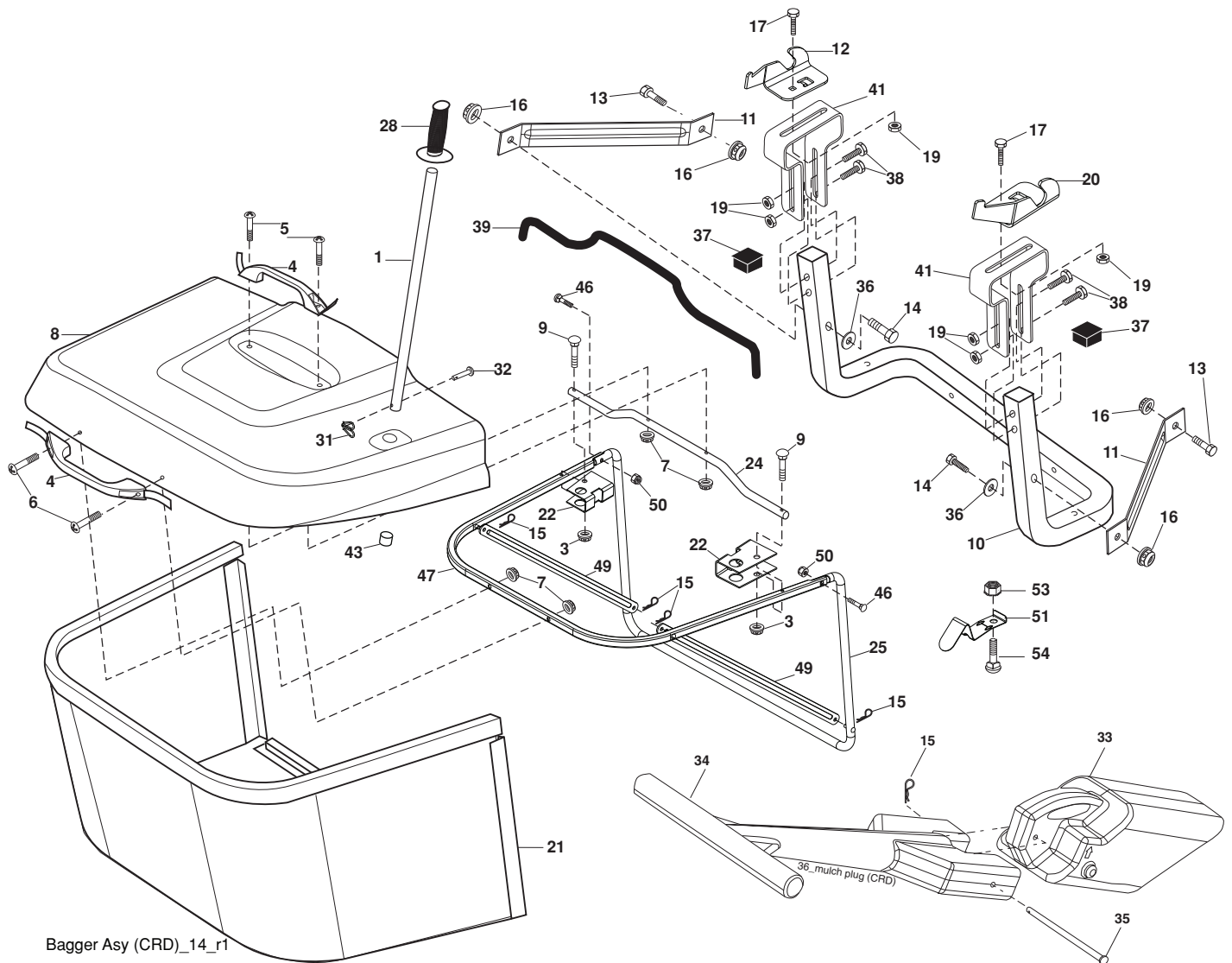

KEY NO.	PART NO.	DESCRIPTION	KEY NO.	PART NO.	DESCRIPTION
1	532 42 86-10	Tube Handle Bagger CRD	28	532 16 57-87	Grip Handle Black
3	532 12 39-76	Nut Lock 1/4 Lge Flg Gr. 5 Zinc	31	532 16 94-84	Retainer Clip
4	532 16 99-16	Handle Bagger w/Lvrs Blk CRD	32	532 12 68-75	Rivet Rd Hd Drilled 3/8 Dia
5	874 98 10-24	Screw Pan Head #10-24 x 1.50 Blk	33	532 42 86-83	Plug Mulcher CRD
6	874 98 10-32	Screw Pan Hd	34	532 16 55-70	Handle Mulcher CRD
7	873 40 10-00	Nut Wiz Lock Hex Serr/Hd 10-24	35	532 16 55-72	Pin Mulcher CRD
8	532 18 10-95	Cover Bagger CRD MS422	36	819 13 20-12	Washer 13/32 x 1-1/4 x 12 Ga.
9	872 14 04-18	Bolt Carriage 1/4-20 x 2.25d x Gr. 5	37	532 17 54-01	Plug Support Bagger CRD
10	532 18 12-82	Tube Support Bagger CRD	38	872 01 05-20	Bolt 5/16-18 x 2-1/2
11	532 16 57-19	Bracket Support Upper Bag CRD	39	532 41 62-57	Seal 37"
12	532 18 88-48	Bracket Pivotn LH	41	532 16 96-83	Bracket Vert Adj Bagger CRD
13	874 76 06-12	Bolt fin Hex 3/8-16 unc x 3/4	43	532 17 40-83	Plug Tubing
14	874 52 06-36	Bolt Carr.	46	872 11 05-10	Bolt Carr. 5/16-18 x 1-1/4 Gr. 5
16	873 90 06-00	Nut Lock Flg. 3/8-16 unc	47	532 19 37-04	Tube Upper Bagger
15	532 12 46-70	Retainer Spring	49	532 19 33-05	Bar Spreader
17	872 14 05-06	Bolt Rdhd Sht Sqnk 5/16-18 unc x 3/4	50	873 80 05-00	Nut Lock Thx w/Ins. 5/16-18 unc
19	873 90 05-00	Nut Lock Hex flange 5/16-18	51	532 19 99-03	Latch Spring Bagger
20	532 18 88-47	Bracket Pivot RH	53	873 51 04-00	Nut Keps Hex 1/4-20 unc
21	532 40 61-80	Bag Asm CRD	54	872 14 04-06	Bolt Rdhd Sqnk 1/4-20 x 3/4 Gr. 5
22	532 16 57-81	Bracket Side Bagger CRD			
24	532 16 57-83	Tube Pivot Bagger CRD			
25	532 19 37-05	Tube Front Bagger CRD			

NOTE: All component dimensions given in U.S. inches
1 inch = 25.4 mm

