

CTH2238 TE

Spare parts

Ersatzteile

Pièces détachées

Reserve onderdelen

Repuestos

Reservdelar

ILLUSTRATED PARTS LIST

MODEL NO. 96061030500

CUSTOMER CATALOG NO. CTH2238TE

PRODUCT NO. 960 61 03-05

**TRACTOR - - MODEL NO. CTH2238TE (96061030500), PRODUCT NO. 960 61 03-05
DECALS 27**

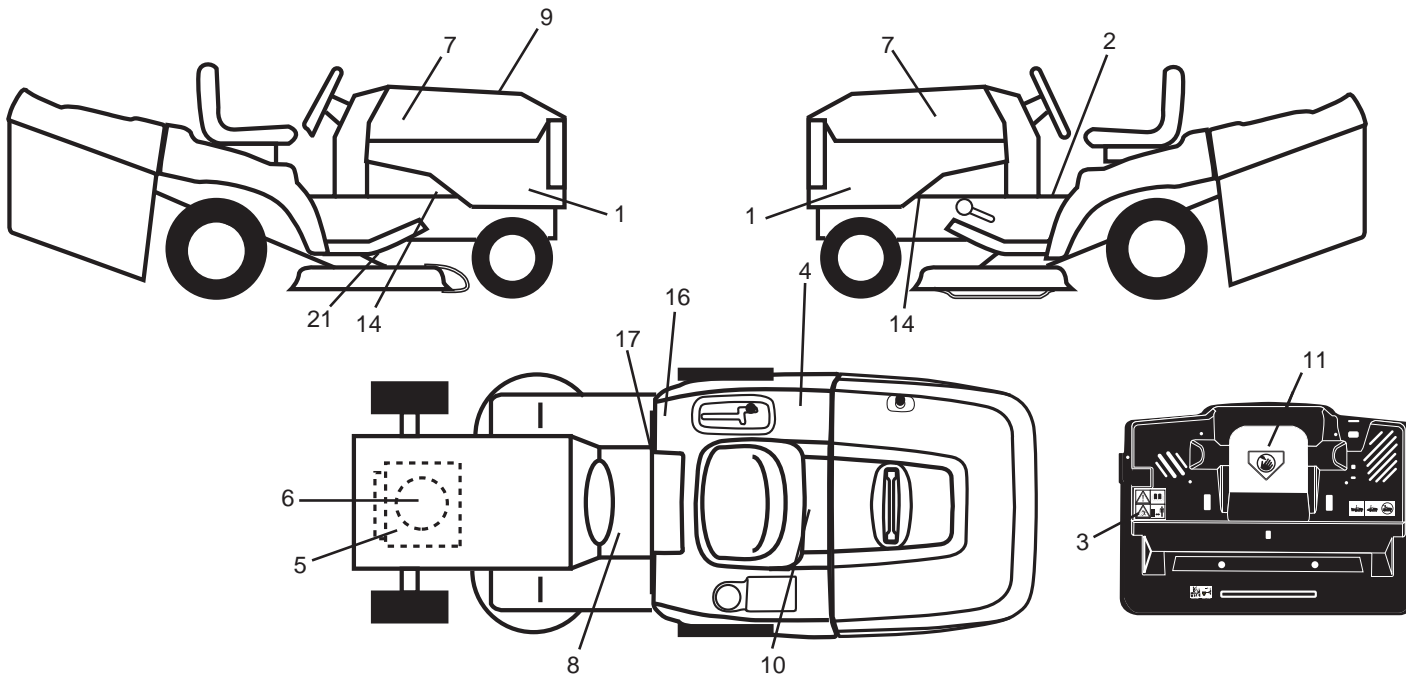

KEY NO.	PART NO.	DESCRIPTION
1	532 43 44-74	Decal, Side Panel
2	532 40 03-89	Decal, Warning Symbols CE
3	532 18 04-35	Decal, Backplate
4	532 12 44-33	Decal, 80 DBA
5	532 43 29-14	Decal, Engine H.P.
6	532 19 68-41	Decal, Warning Engine Symbols
7	532 42 91-96	Decal, Hood RH/LH
8	532 15 97-37	Decal, Brake/Clutch Symbol
9	532 43 37-81	Decal, RPL
10	532 14 50-05	Decal, Bat Dan/Poi P/L Sym Wpn

KEY NO.	PART NO.	DESCRIPTION
11	532 18 21-66	Decal, Mower Cut Finger Symbol
14	532 15 97-36	Decal, Chassis Hot Muffler
16	532 16 88-69	Decal, Tick Mark
17	532 14 08-37	Decal, Saddle Brake Parking
21	532 16 62-86	Decal, Deck Sch 92 CRD
--	532 16 69-60	Decal, Bypass
--	532 13 83-11	Decal, Handle Lift
--	532 18 19-16	Pad Footrest LH
--	532 18 19-17	Pad Footrest RH
--	532 43 37-86	Manual Operators (English)

WHEELS & TIRES

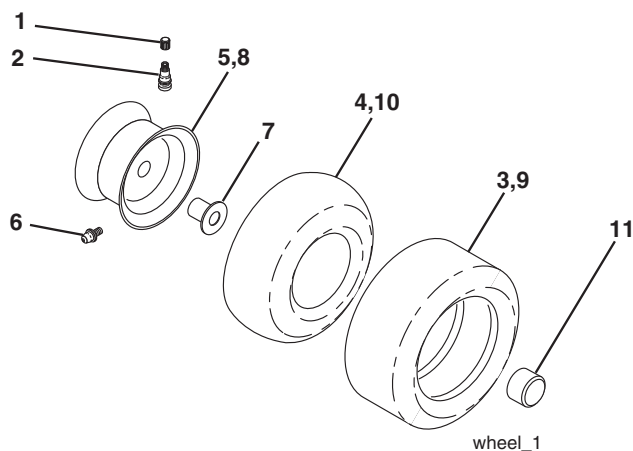

KEY NO.	PART NO.	DESCRIPTION
1	532 05 91-92	Cap Valve Tire
2	532 06 51-39	Stem Valve
3	532 10 62-22	Tire F Ts 15 x 6 0 - 6 Service
4	532 05 99-04	Tube Inner Front #35060
5	532 13 83-36	Rim Asm 6" Front Service
6	532 12 49-57	Fitting Grease
7	532 12 49-59	Bearing Flange
8	532 13 83-37	Rim Asm 8" Rear Service
9	532 12 20-82	Tire R Ts 20 x 10-8 Service
10	532 12 49-26	Tube Rear 9 5 x 8 Service
11	532 17 50-39	Cap Axle Blk 1 50 x 1 00
--	532 14 43-34	Sealant, Tire (10 oz. tube)

NOTE: All component dimensions given in U.S. inches.
1 inch = 25.4 mm

TRACTOR - - MODEL NO. CTH2238TE (96061030500), PRODUCT NO. 960 61 03-05

SCHEMATIC 38

SCH20

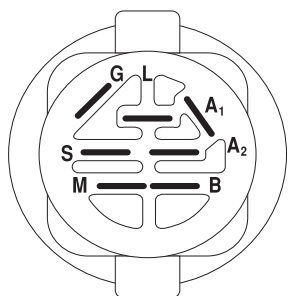
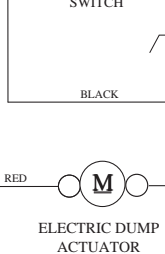
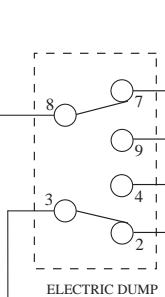
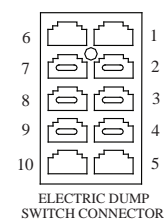
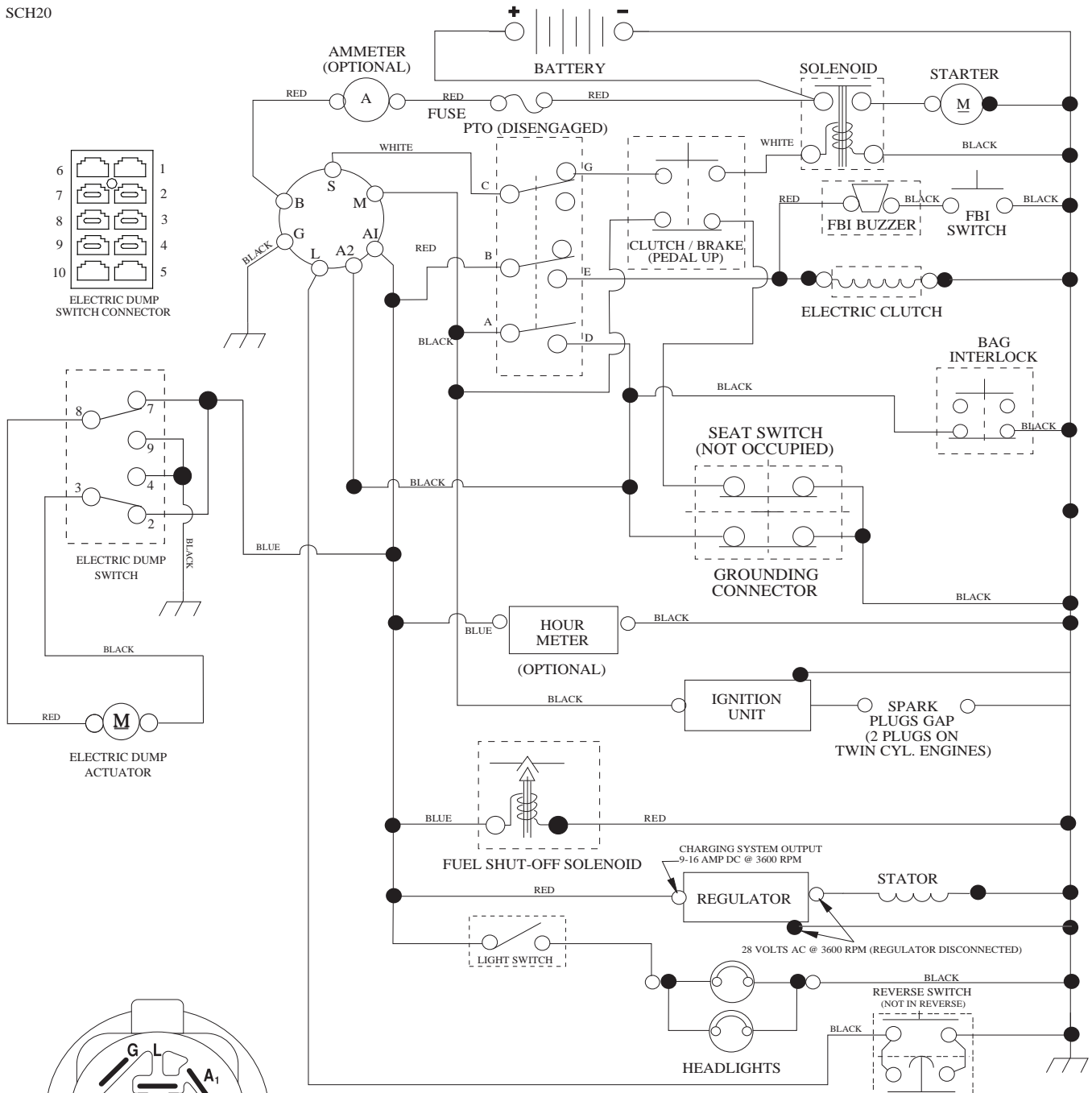

IGNITION SWITCH

POSITION	CIRCUIT	"MAKE"
OFF	M+G+A1	
RUN/OVERRIDE	B+A1	
RUN	B+A1	L+A2
START	B + S + A1	

WIRING INSULATED CLIPS
NOTE: IF WIRING INSULATED CLIPS WERE REMOVED FOR SERVICING OF UNIT, THEY SHOULD BE RE-INSTALLED TO PROPERLY SECURE YOUR WIRING.

PTO SWITCH

POSITION	CIRCUIT
OFF	C + G, B + H
ON	C + F, B + E, A + D

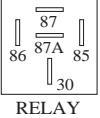

RELAY



● NON-REMOVABLE CONNECTIONS

○ REMOVABLE CONNECTIONS

03048

**TRACTOR - - MODEL NO. CTH2238TE (96061030500), PRODUCT NO. 960 61 03-05
ELECTRICAL 32**

C07

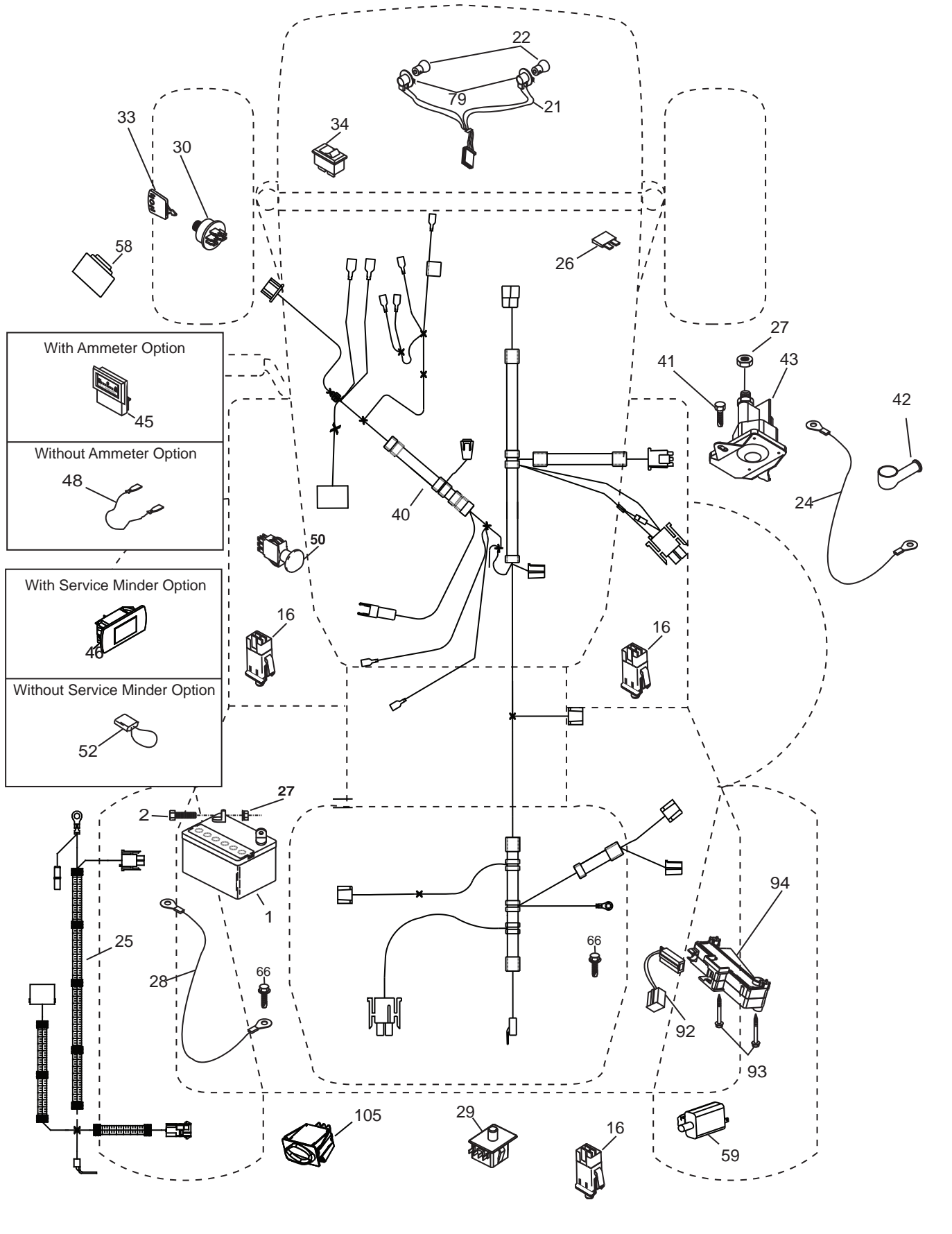

**TRACTOR - - MODEL NO. CTH2238TE (96061030500), PRODUCT NO. 960 61 03-05
ELECTRICAL 32**

KEY NO.	PART NO.	DESCRIPTION
1	532 16 34-65	Battery
2	874 76 04-12	Bolt Hex Hd 1/4-20 unc x 3/4
16	532 17 61-38	Switch Interlock
21	532 18 37-59	Harness Asm Light w/4152J
22	532 00 41-52	Bulb Light #1156
24	532 42 98-69	Cable Battery ACC Elect Dp
25	532 42 12-99	Cable Starter 6 Ga. 11" Red
26	532 17 51-58	Fuse
27	873 51 04-00	Nut Keps Hex 1/4-20 unc
28	532 12 77-25	Cable Ground 6 Ga. 18" Black
29	532 19 27-49	Switch Seat
30	532 19 33-50	Switch Ignition
33	532 41 19-33	Key/Chain
34	532 11 07-12	Switch Light
40	532 42 98-70	Harness Ign
41	871 11 04-08	Bolt Flk Fin Hex 1/4-20 unc x 1/2
42	532 13 15-63	Cover Terminal Red
43	532 19 25-07	Solenoid
46	532 40 17-63	Gauge Hourmeter
48	532 14 08-44	Adapter Ammeter Rectangular
50	532 17 46-51	Switch PTO
58	532 16 94-19	Buzzer CRD
59	532 18 03-79	Switch FBI CRD
66	817 49 06-08	Screw Thdrol 3/8-16 x 1/2 Ty-Tt
79	532 17 52-42	Socket Asm. Bulb Twistlock
92	532 19 66-15	Harness Pigtail
93	532 19 25-40	Screw Plastite 10-14 x 2.0
94	532 19 18-34	Module Reverse
105	532 43 04-44	Switch Rotary

NOTE: All component dimensions given in U.S. inches.
1 inch = 25.4 mm.

TRACTOR - - MODEL NO. CTH2238TE (96061030500), PRODUCT NO. 960 61 03-05
CHASSIS AND ENCLOSURES **39**

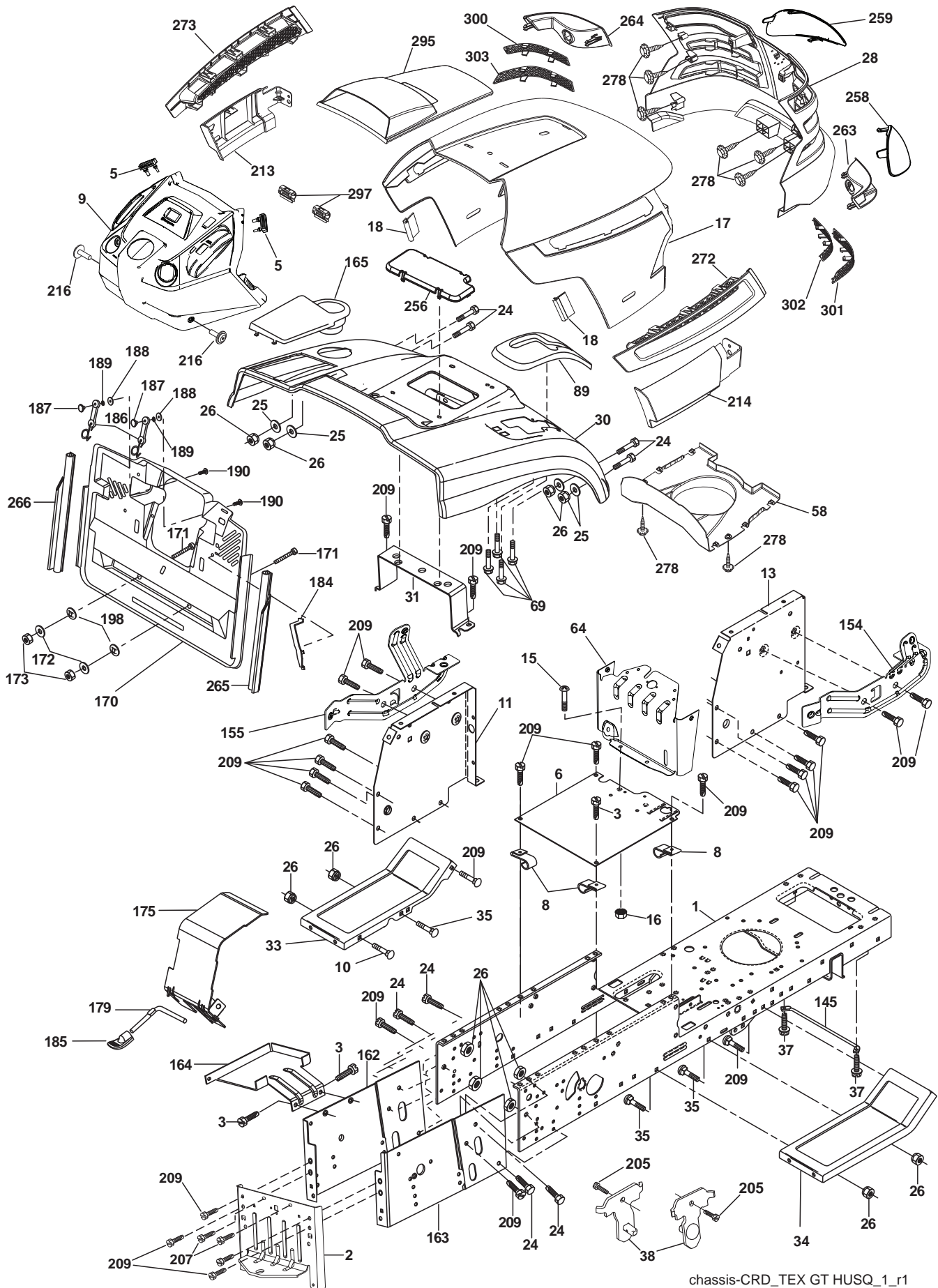

chassis-CRD_TEX GT HUSQ_1_r1

**TRACTOR - - MODEL NO. CTH2238TE (96061030500), PRODUCT NO. 960 61 03-05
CHASSIS AND ENCLOSURES 39**

KEY NO.	PART NO.	DESCRIPTION	KEY NO.	PART NO.	DESCRIPTION
1	532 17 46-20	Chassis	172	819 13 20-16	Washer 13/32 x 1-1/4 x 16 Ga.
2	532 18 03-84	Drawbar	173	873 51 06-00	Nut, Keps Hex 3/8-16 unc
3	817 06 06-12	Screw 3/8-16 x 3/4	175	532 18 82-03	Guard Trap
5	532 40 75-90	Bumper Hood/Dash	179	532 18 82-02	Rod Pivot FBI CRD
6	532 18 44-19	Saddle	184	532 17 46-62	Bracket Actuator Bagger CRD
8	532 12 64-71	Clip Insulator 13/32 Mtg. Hole	185	532 18 11-01	Knob Rod Brake Parking
9	532 40 89-11	Dash Upper	186	532 16 07-93	Latch Asm Mulch/Bagger
10	872 14 06-08	Bolt, Carriage 3/8-16 x 3/4	187	532 12 50-04	Nut Weld
11	532 16 72-03	Panel, Dash, LH	188	819 06 12-16	Washer #10
13	532 17 82-98	Panel, Asm. Dash RH	189	810 07 10-00	Washer Lock #10
15	874 18 05-12	Screw, Machine, THD 5/16-18 unc x 3/4	190	871 08 10-10	Screw Pan Hd Phillip 10-24 x 5/8
16	873 51 05-00	Nut Keps 5/16-18 unc	198	532 16 89-37	Nut, Push
17	532 41 10-46	Hood	205	817 49 06-08	Screw Thdrol 3/8-16 x 1/2
18	532 40 47-42	Bumper Hood	207	817 67 05-08	Screw Thdrol 5/16-18 x 1/2
24	874 78 06-16	Bolt	209	817 00 06-12	Screw Hex Wsh Thdrol 3/8-16
25	819 13 13-12	Washer 13/32 x 13/16 x 12 Ga.	213	532 40 17-11	Skirt Side LH
26	873 80 06-00	Nut	214	532 40 17-09	Skirt Side RH
28	532 40 86-07	Grille/Lens Asm	216	817 06 04-10	Hex Tapping Screw
30	532 19 73-76	Fender	256	532 18 13-61	Cover Fender Rack
31	532 16 51-56	Bracket, Fender Support	258	532 19 89-06	Lens RH
33	532 18 10-57	Footrest, LH	259	532 19 89-07	Lens LH
34	532 18 10-58	Footrest, RH	263	532 19 71-98	Bezel RH
35	872 11 06-06	Bolt	264	532 19 71-99	Bezel LH
37	817 49 05-08	Screw Thdrol 5/16-18 x 1/2 TYT	265	532 18 57-04	Seal RH Side Bagger
38	532 18 17-48	Bracket Asm Pivot Mower Rear	266	532 18 57-03	Seal LH Side Bagger
58	532 19 85-12	Duct Air	272	532 40 30-48	Vent Hood RH
64	532 19 93-95	Dash Lower	273	532 40 30-76	Vent Hood LH
69	532 14 24-32	Screw Hx Wsh Hi-Lo 1/4-1/2	278	532 41 63-58	Screw #10 x .750 BOS Thread
89	532 19 73-77	Console CRD Auto Grey	295	532 41 66-13	Vent Top Hood
145	532 40 91-67	Rod Pivot Chassis/Hood	297	532 19 91-45	Clip Retainer
154	532 40 86-90	Bracket Mounting Dash RH	300	532 19 91-31	Insert Tex Top LH
155	532 40 86-91	Bracket Mounting Dash LH	301	532 19 91-30	Insert Tex Top RH
162	532 18 03-82	Bracket Exten Chassis LH CRD	302	532 19 91-32	Insert Tex Bottom RH
163	532 18 03-83	Bracket Exten Chassis RH CRD	303	532 19 91-33	Insert Tex Bottom LH
164	532 16 56-05	Support Battery CRD	--	532 43 18-83	Kit Bumper
165	532 43 22-76	Cover Battery			
170	532 19 94-88	Backplate CRD			
171	872 14 06-20	Bolt Rdhd Sqnk 3/8-16 x 2-1/2 Gr. 5			

NOTE: All component dimensions given in U.S. inches.
1 inch = 25.4 mm.

TRACTOR - - MODEL NO. CTH2238TE (96061030500), PRODUCT NO. 960 61 03-05
 DRIVE **40**

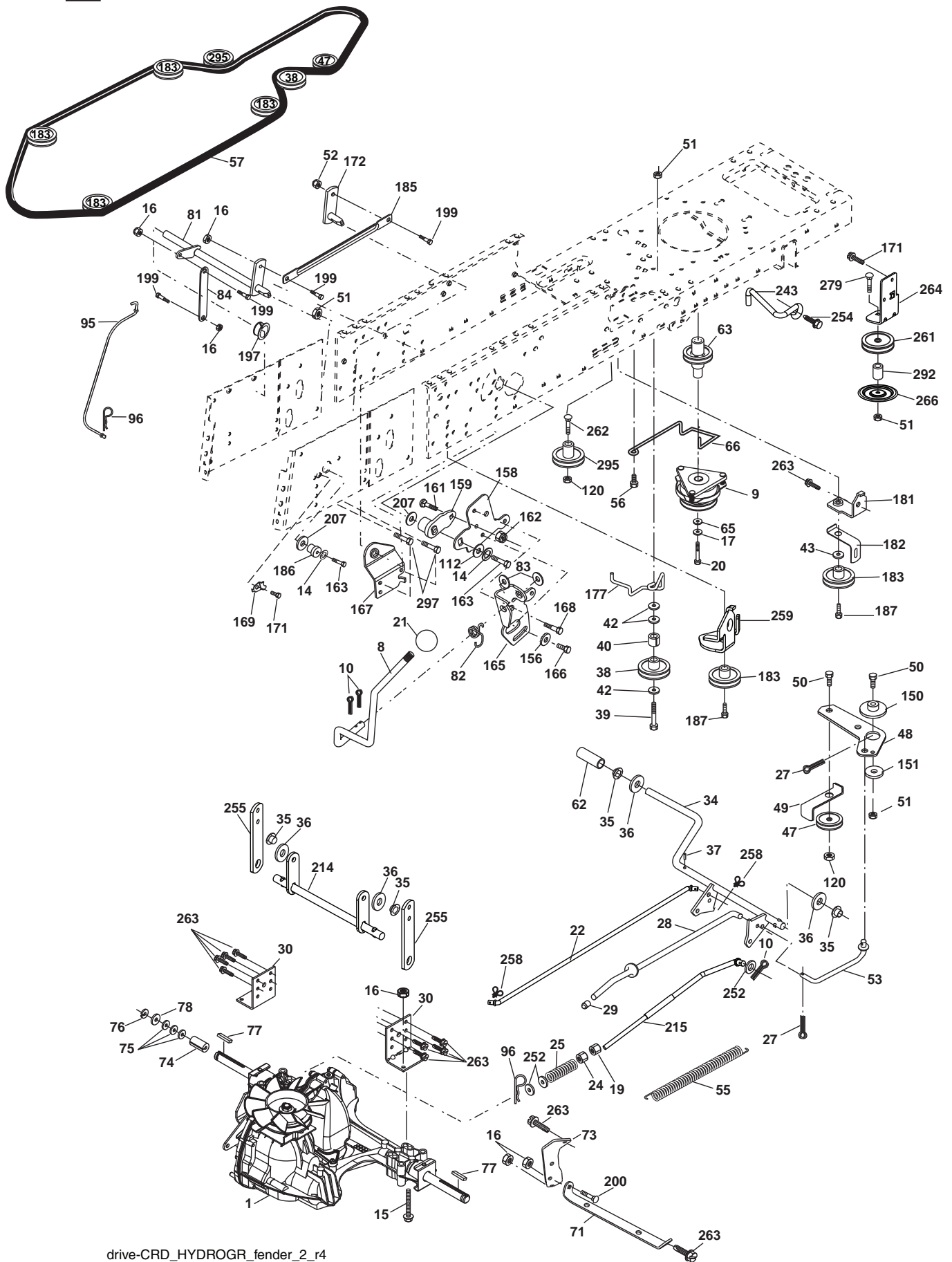

drive-CRD_HYDROGR_fender_2_r4

**TRACTOR - - MODEL NO. CTH2238TE (96061030500), PRODUCT NO. 960 61 03-05
DRIVE **40****

KEY NO.	PART NO.	DESCRIPTION	KEY NO.	PART NO.	DESCRIPTION
1	-----	Transaxle Hydro Gear 321-0510	95	532 17 00-15	Control Asm Bypass Hydro
8	532 19 27-06	Rod, Shift Fender Adjust LT	96	532 12 47-88	Spring, Retainer 1"
9	532 19 81-43	Clutch Electric	112	819 09 12-10	Washer 9/32 x 3/4 x 10 Ga.
10	876 02 04-16	Pin, Cotter 1/8 x 1	120	873 90 06-00	Nut Lock Flg. 3/8-16 unc
14	810 04 04-00	Washer, Lock Hvy Helical	150	532 16 58-50	Bushing, Bellcrank Grnd Dr
15	874 49 05-44	Bolt Hex FGHD 5/16-18 x Gr. 5	151	819 13 32-10	Washer 13/32 x 2 x 10 Ga.
16	873 80 05-00	Nut Lock Hex w/Ins 5/16-18 unc	156	532 16 60-02	Washer Srrted 5/16 ID x 1.125
17	532 12 61-97	Washer 1-1/2 x 15/32 x .250	158	532 16 55-89	Bracket Shift Mount
19	873 80 06-00	Nut Lock Hex w/Ins 3/8-16 unc	159	532 18 39-00	Hub Shift
20	532 17 39-37	Bolt Hex 7/16-20 x 4 Gr. 5	161	872 14 04-06	Bolt Rdhd Sqnk 1/4-20 x 3/4 Gr. 5
21	532 12 12-74	Knob Duckhead 1/4-13 unc Blk	162	873 68 04-00	Nut Crownlock 1/4-20 unc
22	532 17 56-07	Rod Brake Main	163	874 78 04-16	Bolt Hex Fin 1/4-20 unc x 1 Gr. 5
24	873 35 06-00	Nut Hex Jam 3/8-16 unc	165	532 16 56-23	Bracket Pivot Lever
25	532 19 20-36	Spring, Rod, Brake	166	817 49 05-10	Screw 5/16-18 x 5/8
27	876 02 04-12	Pin, Cotter 1/8 x 3/4	167	532 16 55-88	Bracket Support Shift CRD
28	532 17 57-65	Rod, Parking Brake	168	532 16 54-92	Bolt Shoulder 5/16-18 x .561
29	532 07 16-73	Cap, Parking Brake	169	532 16 55-80	Plate Fastening Lt
30	532 16 95-92	Bracket, Mfg. Transaxle	171	817 49 06-08	Screw Thdrol 3/8-16 x 1/2 Ty-Tt
34	532 17 55-78	Shaft, Asm Pedal Foot CRD	172	532 17 02-71	Shaft Asm Shifter Frt CRD
35	532 12 01-83	Bearing, Nylon	177	532 16 59-32	Keeper Flat Idler 3.06" CRD
36	819 21 16-16	Washer 21/32 x 1 x 16 Ga.	181	532 18 02-11	Bracket Idler Ground Drive CRD
37	532 12 49-63	Pin, Roll 3/16 x 1"	182	532 18 26-82	Keeper Belt 2.5" Od V-Idler CRD
38	532 16 59-36	Pulley Flat Composite 3.06"	183	532 19 95-34	Pulley V-Idler 2.50" Od CRD
39	874 76 06-44	Bolt Fin Hex 3/8-16 unc x 2-3/4	185	532 17 00-08	Link Shift
40	532 12 49-65	Spacer, Split 395 x 59 Bzp	186	532 16 56-14	Hub Tapered Round CRD
42	819 13 13-12	Washer 13/32 x 13/16 x 12 Ga.	187	817 58 05-20	Screw Thdrol 5/16-18 x 1.25
43	819 11 10-12	Washer 11/32 x 5/8 x 12 Ga.	197	532 16 96-13	Nyliner Snap-In 5/8
47	532 12 77-83	Pulley, Idler, V Groove Plastic	199	532 16 96-12	Bolt Shoulder 5/16-18 unc
48	532 15 44-07	Bellcrank Clutch Grnd Drv	200	872 14 05-08	Bolt RDHD SQNK 5/16-18 x 1
49	532 12 32-05	Retainer, Belt Style Spring	207	532 16 98-45	Washer Nylon Rear
50	872 11 06-12	Bolt Carr. Sh. 3/8-16 x 1-1/2 Gr. 5	214	532 17 56-09	Shaft Asm. Brake
51	873 68 06-00	Nut, Crownlock 3/8-16 unc	215	532 17 56-52	Rod Brake Hydro
52	873 68 05-00	Nut, Crownlock 5/16-18	243	532 19 07-36	Bracket Anti-Rotation
53	532 19 96-52	Link, Clutch 7.66	252	819 13 16-16	Washer 13/32 x 1 x 16 Ga.
55	532 10 57-09	Spring, Return, Clutch	254	817 00 06-16	Screw 3/8-16 x 1
56	817 06 06-20	Screw 3/8-16 x 1-1/4	255	532 17 56-08	Brace Shaft Brake Mtg.
57	532 17 01-40	V-Belt Kev 112" 0650 CRD	258	532 17 80-62	Clip Retainer
62	532 12 35-33	Cover, Pedal	259	532 18 02-12	Bracket Pulley
63	532 18 03-97	Pulley Engine	261	532 13 14-94	Pulley Idler
65	810 04 07-00	Washer	262	872 11 06-22	Bolt Carr. 3/8-16 x 2-3/4 Gr. 5
66	532 15 47-78	Keeper, Belt Engine F-Proof	263	817 00 06-12	Screw 3/8-16 x 3/4
71	532 16 91-83	Strap, Torque, LH	264	532 43 11-72	Bracket Idler Chassis Elect.
73	532 16 91-82	Strap, Torque, RH	266	532 18 20-61	Shield Idler Mower
74	532 13 70-57	Spacer, Split	279	872 11 06-16	Bolt 3/8-16 unc x 2
75	532 12 17-49	Washer 25/32 x 1-1/4 x 16 Ga.	292	532 40 02-71	Spacer
76	812 00 00-01	Ring, E	295	532 17 91-14	Pulley Idler Composite
77	532 12 35-83	Key, Square	297	817 49 06-10	Screw 3/8 - 16 x 5/8
78	532 12 17-48	Washer 25/32 x 1-5/8 x 16 Ga.			
81	532 17 00-06	Asm, Shaft, Cross Rear			
82	532 16 57-11	Spring, Torsion			
83	819 17 12-16	Washer 17/32 x 3/4 x 16 Ga.			
84	532 17 00-07	Link, Transaxle			

NOTE: All component dimensions given in U.S. inches
1 inch = 25.4 mm

TRACTOR - - MODEL NO. CTH2238TE (96061030500), PRODUCT NO. 960 61 03-05
ENGINE **24**

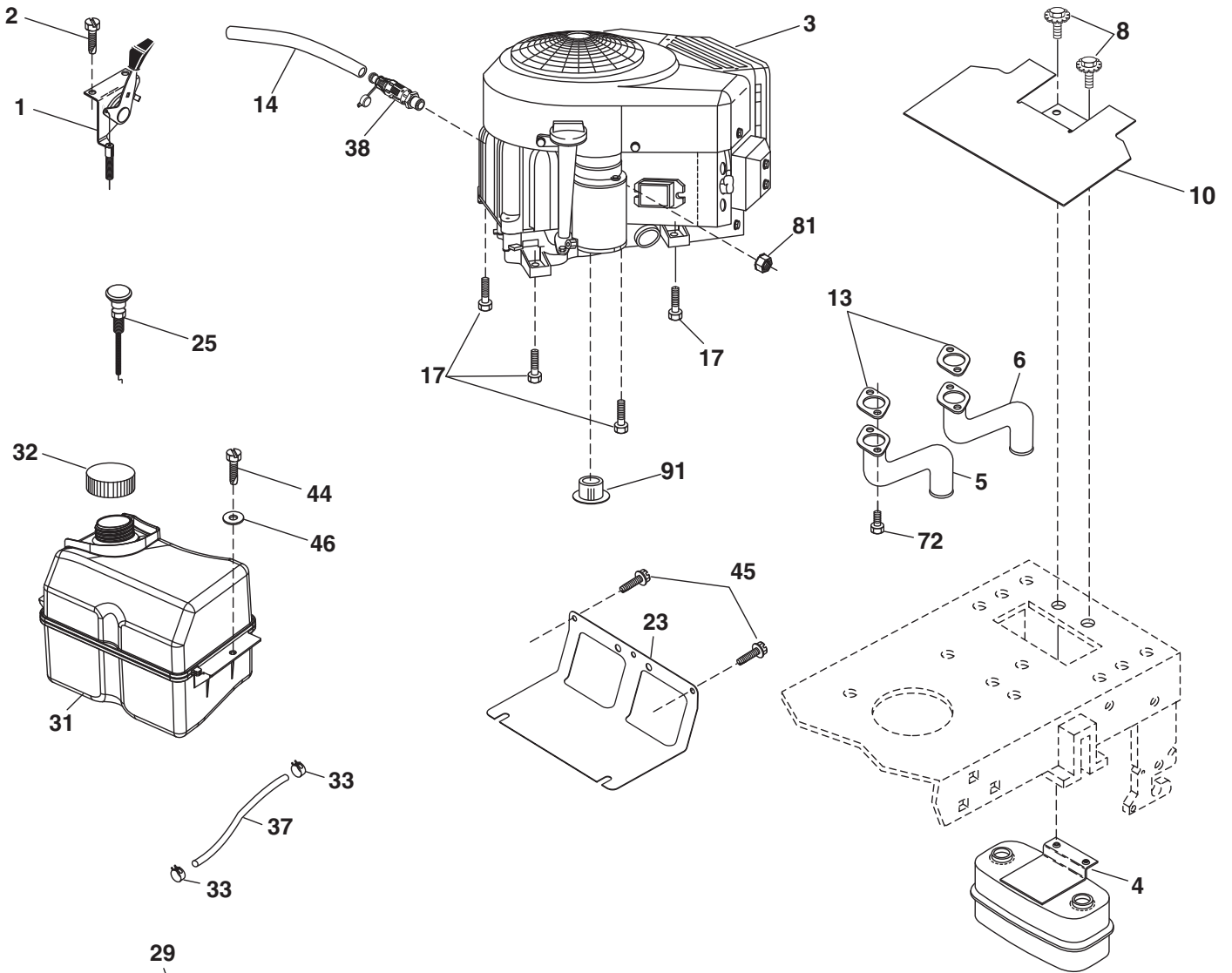

OPTIONAL EQUIPMENT
Spark Arrester

Engine-CRD_bs-2cyl_7

**TRACTOR - - MODEL NO. CTH2238TE (96061030500), PRODUCT NO. 960 61 03-05
ENGINE 24**

KEY NO.	PART NO.	DESCRIPTION
1	532 17 83-85	Control Throttle
2	532 41 63-58	Screw #10 x .750 BOS Thread
3	-----	Engine B & S 40H777-1456-B1
4	532 14 97-23	Muffler Exhaust
5	532 15 99-55	Tube, Exhaust LH
6	532 16 05-89	Tube, Exhaust RH
8	532 17 18-77	Bolt 5/16-18 x 3/4
10	532 43 40-17	Shield Browning Intek
13	532 16 53-91	Gasket
14	532 14 84-56	Tube Drain Oil Easy
17	817 06 06-20	Screw 3/8-16 x 1-1/4
23	532 16 98-37	Shield Browning/Debris Guard
25	532 19 15-96	Choke Control
29	532 13 71-80	Arrestor Spark
31	532 40 74-89	Tank Fuel
32	532 43 02-20	Cap Asm Fuel Top
33	532 12 34-87	Clamp Hose Blk
37	532 13 70-40	Line Fuel 20"
38	532 42 82-87	Valve Drain Oil
44	817 67 04-12	Screw Hexwsh Thdrol 1/4-20 x 3/4
45	817 00 06-12	Screw Hexwsh Thdr 3/8-16 x 3/4
46	819 09 14-16	Washer 9/32 x 7/8 x 16 Ga.
72	532 18 39-06	Screw Socket Head 5/16-18 x 1
81	873 51 04-00	Nut Keps 1/4-20 unc
91	532 18 74-95	Bushing 1.375 OD

NOTE: All component dimensions given in U.S. inches
1 inch = 25.4 mm

For engine service and replacement parts, call the toll free number for your engine manufacturer listed below:

Briggs & Stratton 1-800-233-3723

Engine Power Rating Information

The gross power rating for individual gas engine models is labeled in accordance with SAE (Society of Automotive Engineers) code J1940 (Small Engine Power & Torque Rating Procedure), and rating performance has been obtained and corrected in accordance with SAE J1995 (Revision 2002-05). Torque values are derived at 3060 RPM; horsepower values are derived at 3600 RPM. Actual gross engine power will be lower and is affected by, among other things, ambient operating conditions and engine-to-engine variability. Given both the wide array of products on which engines are placed and the variety of environmental issues applicable to operating the equipment, the gas engine will not develop the rated gross power when used in a given piece of power equipment (actual "on-site" or net power). This difference is due to a variety of factors including, but not limited to, accessories (air cleaner, exhaust, charging, cooling, carburetor, fuel pump, etc.), application limitations, ambient operating conditions (temperature, humidity, altitude), and engine-to-engine variability. Due to manufacturing and capacity limitations, Briggs & Stratton may substitute an engine of higher rated power for this Series engine.

TRACTOR - - MODEL NO. CTH2238TE (96061030500), PRODUCT NO. 960 61 03-05
 STEERING ASSEMBLY **41**

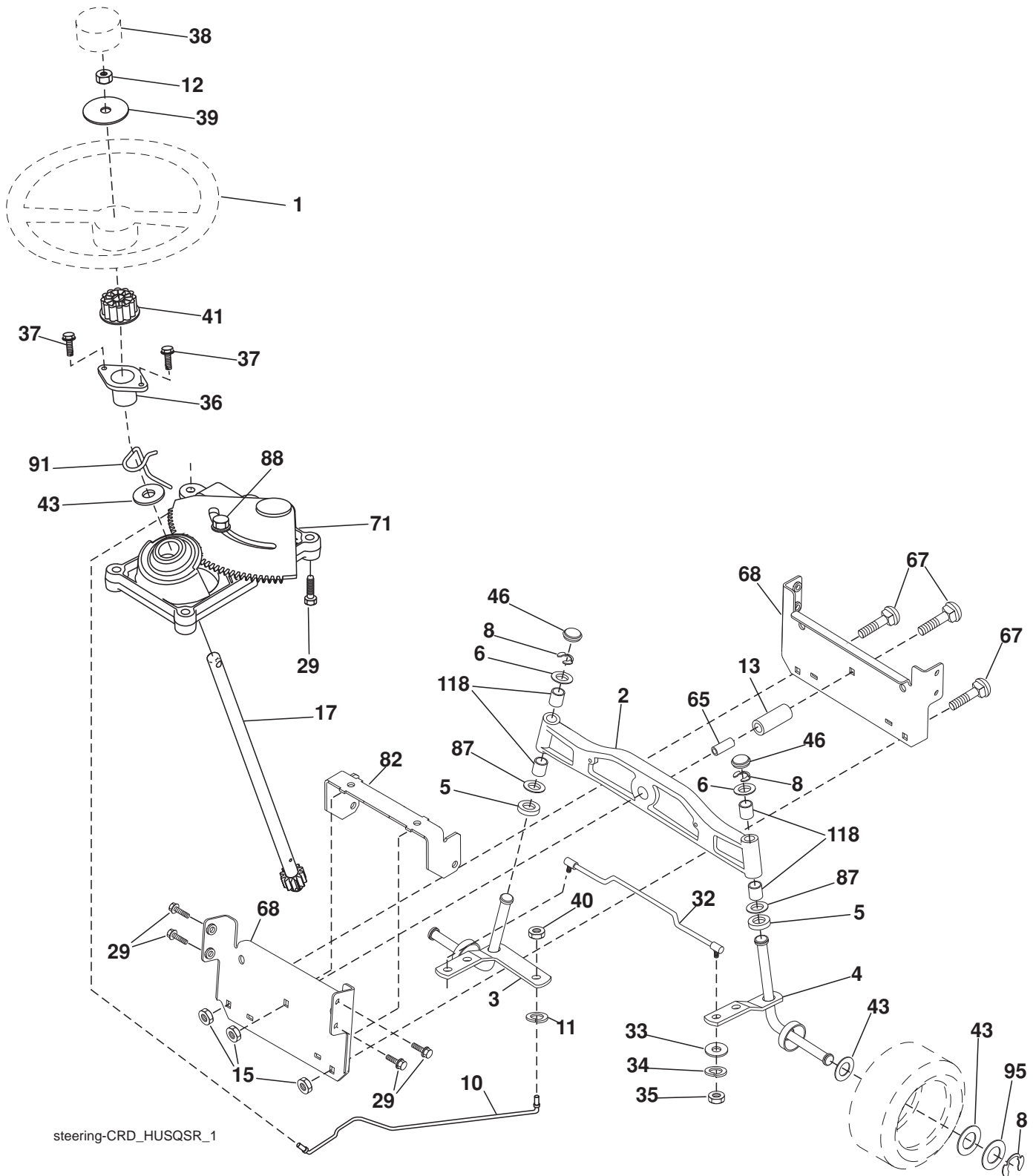

**TRACTOR - - MODEL NO. CTH2238TE (96061030500), PRODUCT NO. 960 61 03-05
STEERING ASSEMBLY **41****

KEY NO.	PART NO.	DESCRIPTION
1	532 41 64-80	Steering Wheel
2	532 19 35-42	Axle Asm Cast Iron Lt
3	532 16 98-40	Spindle Assembly, LH
4	532 16 98-39	Spindle Assembly, RH
5	532 12 49-31	Washer, Thrust
6	532 12 17-48	Washer 25/32 x 1-5/8 x 16 Ga.
8	812 00 00-29	Ring, Klip
10	532 17 51-21	Link, Drag
11	810 04 06-00	Washer, Lock
12	873 94 08-00	Nut Hex Jam Toplock 1/2-20 unf
13	532 13 65-18	Spacer Brg Axle Front
15	873 90 06-00	Nut Flange Lock 3/8-16 unc
17	532 17 78-83	Shaft, Steering
29	817 00 06-12	Screw 3/8-16 x 3/4
32	532 17 18-88	Rod, Tie
33	819 11 12-16	Washer 11/32 x 3/4 x 16 Ga.
34	810 04 05-00	Washer Lock Hvy Hlcl Spr 5/16
35	873 54 05-00	Crownlock Nut 5/16-24 unf 3847
36	532 15 51-05	Bushing, Steering
37	532 15 29-27	Screw TT #10-32 x 5 x 3/8 Flange
38	532 41 59-87	Cap Wheel Steering
39	819 18 38-12	Washer 9/16 ID x 2- 3/8 OD x 12 Ga.
40	873 54 06-00	Nut Lock 3/8-24
41	532 18 67-37	Adaptor, Steering Wheel
43	532 12 17-49	Washer 25/32 x 1-1/4 x 16 Ga.
46	532 12 12-32	Cap, Spindle
65	532 41 47-36	Spacer Brace Axle
67	872 11 06-18	Bolt Rdhd Sqnk 3/8-16 x 2-1/4
68	532 16 98-27	Brace Axle
71	532 17 51-46	Steering Asm.
82	532 19 99-78	Bracket Susp Chassis Front
87	532 17 39-66	Washer Flat .781 x 1 1/2 x .14
88	532 17 51-18	Bolt Shoulder 7/16-20 unc
91	532 17 55-53	Clip Steering
95	532 18 89-67	Washer
118	532 40 60-13	Bushing

NOTE: All component dimensions given in U.S. inches.
1 inch = 25.4 mm.

**TRACTOR - - MODEL NO. CTH2238TE (96061030500), PRODUCT NO. 960 61 03-05
SEAT ASSEMBLY 42**

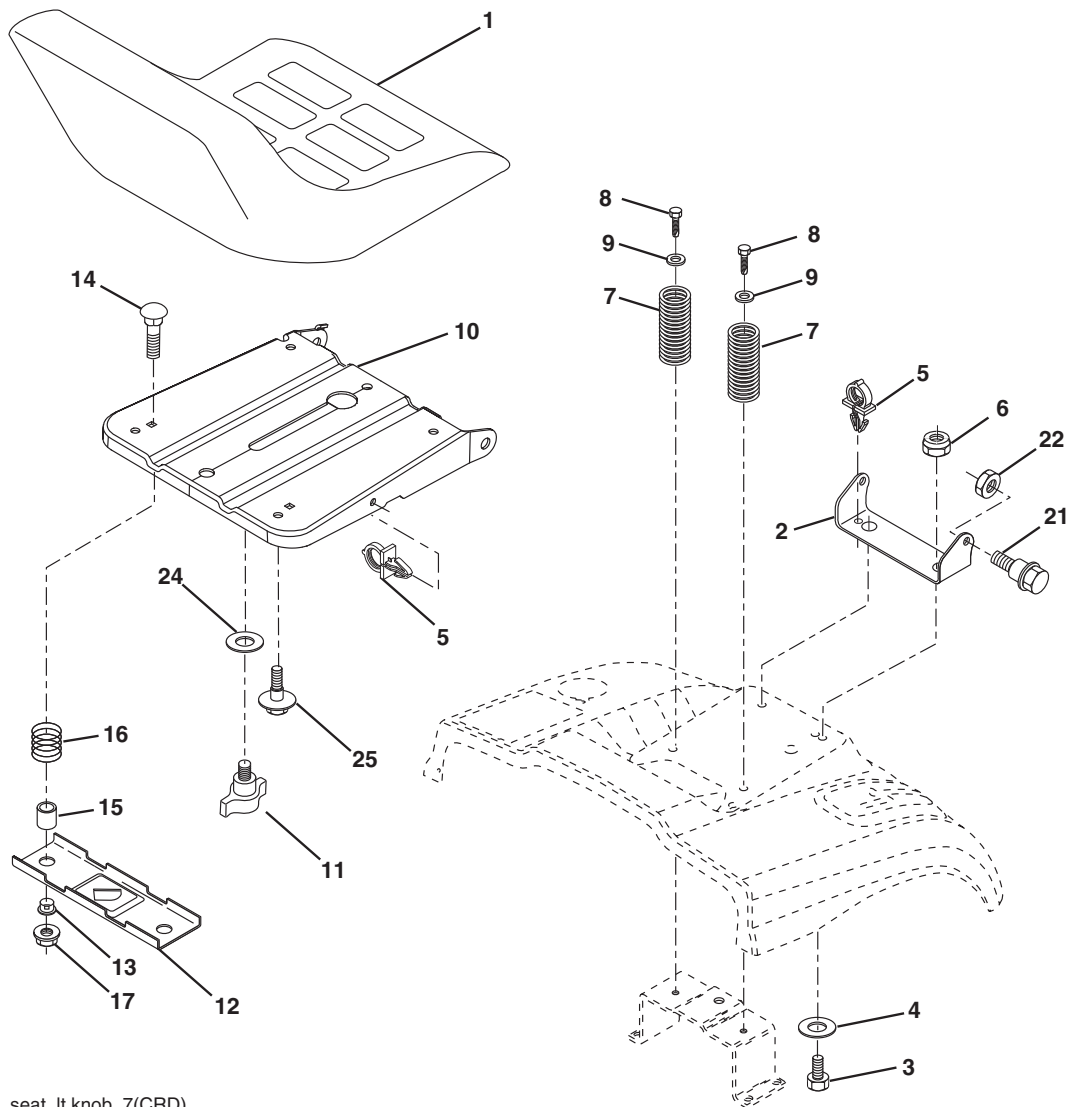

seat_lt.knob_7(CRD)

KEY NO.	PART NO.	DESCRIPTION
1	532 18 87-15	Seat
2	532 14 05-51	Bracket Pnt Pivot Seat (Blk)
3	871 11 06-16	Bolt Fin Hex 3/8-16 x 1
4	819 13 16-10	Washer Flat 13/32 x 1 x 10 Ga.
5	532 14 50-06	Clip Push-in Hinged
6	873 80 06-00	Nut Lock Hx w/Ins. 3/8-16
7	532 12 41-81	Spring Seat Cprsn 2 250 Blk Zi
8	817 00 06-16	Screw 3/8-16 x 1-1/2
9	819 13 16-14	Washer 13/32 x 1 x 14 Ga.
10	532 19 55-30	Pan Pnt Seat
11	532 16 63-69	Knob Seat Adj. Wingnut
12	532 17 46-48	Bracket Pnt Mounting Switch
13	532 12 12-48	Bushing Snap Blk Nyl 50 Id

KEY NO.	PART NO.	DESCRIPTION
14	872 05 04-12	Bolt Rdhd Sht Nk 1/4-20 x 1-1/2
15	532 12 12-49	Spacer Split
16	532 12 37-40	Spring Cprsn Plate
17	532 12 39-76	Nut Lock 1/4 Lge Flg Gr. 5 Zinc
21	532 17 18-52	Bolt Shoulder 5/16-18 unc-2A
22	873 80 05-00	Nut Hex Lock w/Ins 5/16-18
24	819 17 19-12	Washer 17/32 x 1-3/16 x 12 Ga.
25	532 12 70-18	Bolt Shoulder 5/16-18 x 62

NOTE: All component dimensions given in U.S. inches.
1 inch = 25.4 mm

TRACTOR - - MODEL NO. CTH2238TE (96061030500), PRODUCT NO. 960 61 03-05
MOWER LIFT 45

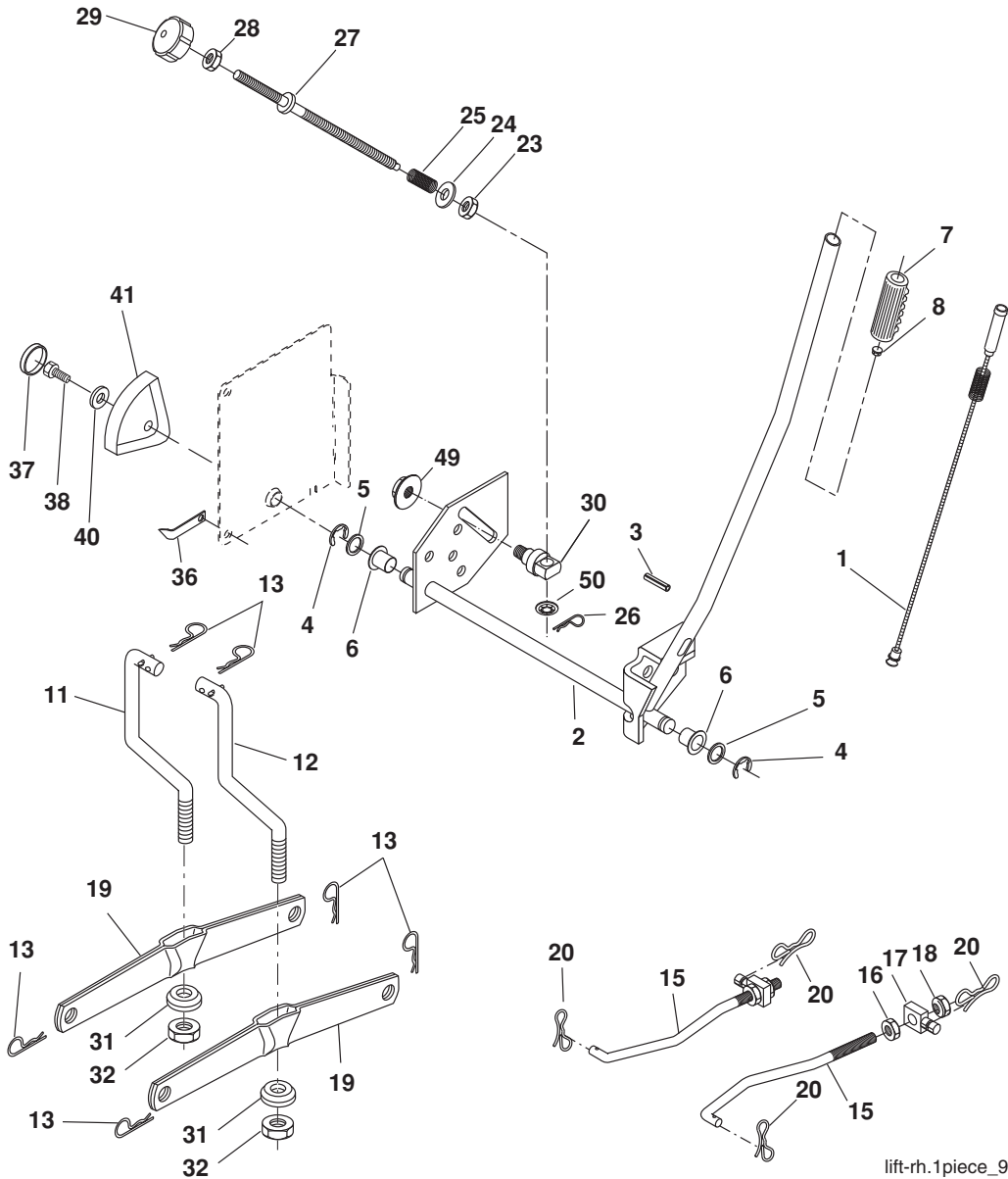

lift-rh.1piece_9

KEY NO.	PART NO.	DESCRIPTION
1	532 40 50-07	Plunger Asm. Lift
2	532 19 80-70	Shaft Asm. Lift
3	532 18 88-22	Pin Groove
4	812 00 00-02	E Ring #5133-62
5	819 21 16-21	Washer 21/32 x 1 x 21 Ga.
6	532 12 01-83	Bearing Nylon
7	532 12 56-31	Grip Handle
8	532 12 45-26	Button Plunger Black
11	532 13 98-65	Link Lift LH
12	532 13 98-66	Link Lift RH
13	532 12 46-70	Retainer Spring
15	532 17 32-88	Link Front
16	873 35 08-00	Nut Jam Hex 1/2-13 unc
17	532 17 56-89	Trunnion
18	873 80 08-00	Nut Lock w/Wsh 1/2-13 unc
19	532 13 98-68	Arm Suspension Mower
20	532 19 42-09	Pin Cotter 7/16 Bow Tie Lock
23	532 11 08-07	Nut Special
24	819 13 10-16	Washer 13/32 x 5/8 x 16 Ga.

KEY NO.	PART NO.	DESCRIPTION
25	532 16 40-24	Spring 2-1/8
26	532 16 94-84	Retainer Clip
27	532 16 45-43	Rod Adj Lift Zinc
28	873 35 06-00	Nut Hex Jam 3/8-16 unc
29	532 13 80-57	Knob Inf 3/8-16 unc
30	532 15 02-33	Trunnion Infin Height
31	532 16 98-65	Bearing, Pvt. Lift.
32	873 54 06-00	Nut Crownlock 3/8-24
36	532 15 50-97	Pointer Height Indicator
37	532 12 39-35	Plug Hole Blk
38	817 06 05-16	Screw 5/16-18 x 1
40	819 11 24-10	Washer 11/32 x 1-1/2 x 10 Ga.
41	532 12 39-34	Scale Ind Height Blk
49	532 14 52-12	Nut Hex Flange Lock
50	532 11 04-52	Nut Push Phos & Oil

NOTE: All component dimensions given in U.S. inches
 1 inch = 25.4 mm

TRACTOR - - MODEL NO. CTH2238TE (96061030500), PRODUCT NO. 960 61 03-05
MOWER DECK **44**

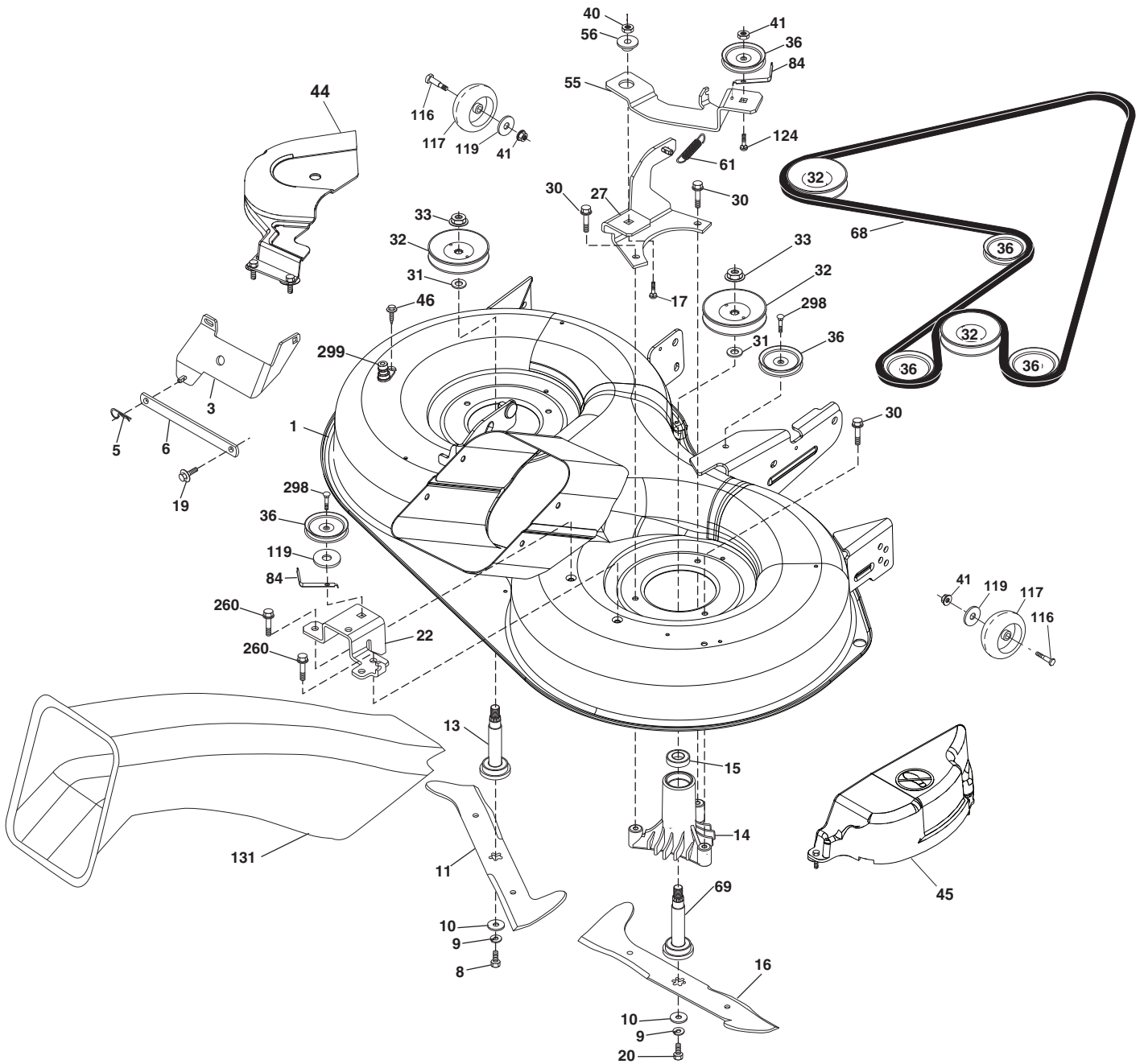

**TRACTOR - - MODEL NO. CTH2238TE (96061030500), PRODUCT NO. 960 61 03-05
MOWER DECK 44**

KEY NO.	PART NO.	DESCRIPTION	KEY NO.	PART NO.	DESCRIPTION
1	532 44 29-25	Housing Asm. Mower	56	532 16 57-23	Spacer Retainer Mower
3	532 43 18-64	Bracket Asm. S-Bar Chass	61	532 19 94-86	Spring Tension Belt
5	532 12 46-70	Retainer Spring	68	532 42 95-32	Drive Belt
6	532 16 55-57	Bar Sway	69	532 16 54-82	Shaft Asm w/Lwr Brg RH Thd
8	532 18 17-12	Bolt 3/8-24 x 1.25 Gr. 8 Patched	84	532 15 60-85	Keeper Belt Idler
9	810 03 06-00	Washer Lock Hvy 3/8 Unplated	116	532 19 34-06	Bolt Shoulder
10	532 14 02-96	Washer Hard Blade Mower Vented	117	532 17 48-73	Wheel Gauge
11	532 42 79-84	Blade 3-1 LH	119	819 13 20-12	Washer 13/32 x 1-1/4 x 12 Ga.
13	532 13 76-45	Shaft Asm. w/Lower Bearing	124	872 11 06-12	Bolt Carr Sh 3/8-16 x 1-1/2 Gr. 5
14	532 12 87-74	Housing Mandrel Vented (Machd)	131	532 16 56-61	Chute Bagger
15	532 11 04-85	Bearing Ball Mandrel	260	817 67 06-08	Screw 3/8-16 x 1/2
16	532 42 79-85	Blade 3-1 RH	298	817 49 06-28	Screw 3/8-16 x 1-3/4
17	872 14 06-10	Bolt Carriage 3/8-16 x 1-1/4	299	532 41 55-98	Port Washout
19	532 13 28-27	Bolt Shoulder 5/16-18 Thd Form	--	532 18 18-57	Mandrel Assembly (Includes housing, shaft assembly, and bearing only - pulley/nut/washer and blade bolt/washers not included)
20	532 18 17-13	Bolt 3/8-24 x 1.25 Gr. 8 Ptch Lhthd	--	532 18 18-58	Mandrel Asm CRD LH Threads SVC
22	532 43 11-69	Bracket Idler Sprt Rear RH	--	532 43 47-05	Replacement Mower, Complete (Std. Deck - Order separately gauge wheel components key nos. 116-119)
27	532 42 79-81	Bracket Asm. Susp. Rear RH			
30	532 17 39-84	Screw Thd Rolling			
31	532 18 76-90	Washer Spacer Mower Vented			
32	532 15 35-32	Mandrel Pulleys			
33	532 40 02-34	Nut Flg Top Lock			
36	532 14 67-63	Pulley Idler V-Groove Dim 4.25			
40	873 68 06-00	Nut Crownlock 3/8-16 unc			
41	873 90 06-00	Nut Lock Flg. 3/8-16 unc			
44	532 43 49-46	Cover Mandrel LH			
45	532 44 14-79	Cover Mandrel RH			
46	532 13 77-29	Screw Thd Roll 1/4-20 x 5/8			
55	532 19 94-98	Arm Idler			

NOTE: All component dimensions given in U.S. inches
1 inch = 25.4 mm

TRACTOR - - MODEL NO. CTH2238TE (96061030500), PRODUCT NO. 960 61 03-05
BAGGER **46**

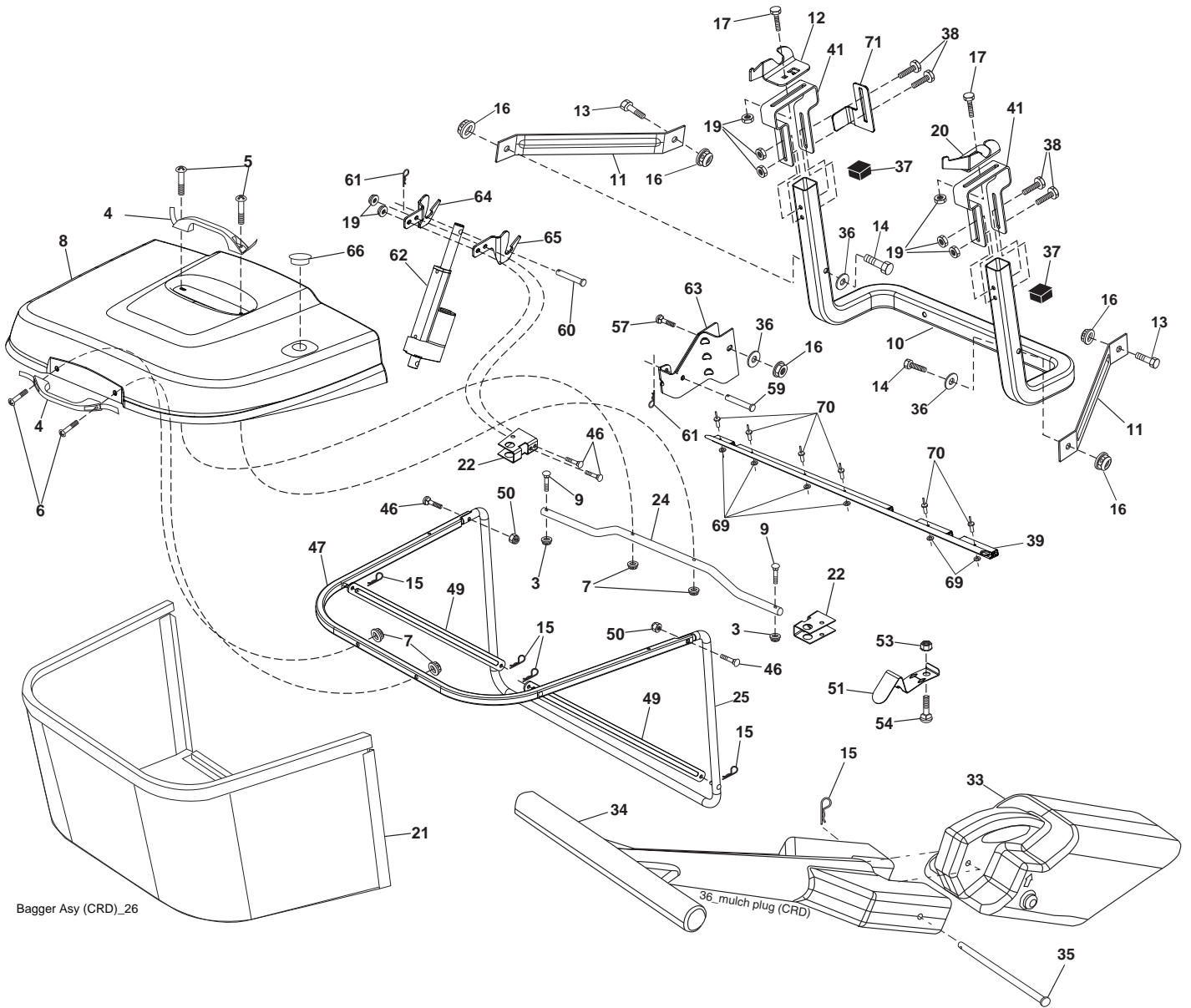

Bagger Asy (CRD)_26

**TRACTOR - - MODEL NO. CTH2238TE (96061030500), PRODUCT NO. 960 61 03-05
BAGGER 46**

KEY NO.	PART NO.	DESCRIPTION	KEY NO.	PART NO.	DESCRIPTION
3	532 12 39-76	Nut Lock 1/4 Lge Flg Gr. 5 Zinc	38	872 01 05-20	Bolt 5/16-18 x 2-1/2
4	532 16 99-16	Handle Bagger w/Lvrs Blk CRD	39	532 41 62-57	Seal
5	874 98 10-24	Screw Pan Head #10-24 x 1.50 Blk	41	532 16 96-83	Bracket Pnt Adj Pvt Bagger CRD
6	874 98 10-32	Screw Pan Hd	46	872 11 05-10	Bolt 5/16-18 x 1-1/4
7	873 40 10-00	Nut Wiz Lock Hex Serr/Hd 10-24	47	532 19 37-04	Tube Upper Bagger
8	532 18 10-95	Cover Bagger	49	532 19 33-05	Bar Spreader
9	872 14 04-18	Bolt Carriage 1/4-20 x 2.25d x Gr. 5	50	873 80 05-00	Nut 5/16-18
10	532 18 12-82	Tube Support Bagger CRD	51	532 19 99-03	Latch Spring Bagger
11	532 16 57-19	Bracket Support Upper Bag	53	873 51 04-00	Nut 1/4-20 unc
12	532 18 88-48	Bracket Pivot LH	54	872 14 04-06	Bolt 1/4-20 x 3/4 Gr. 5
13	874 76 06-12	Bolt Fin Hex 3/8-16 unc x 3/4	57	872 14 06-22	Bolt Rdhd Sqnk
14	874 52 06-36	Bolt Fin Hex 3/8-16 x 2-1/4 Gr. 5	59	532 43 04-22	Pin Clevis 0.375 x 2.375
15	532 12 46-70	Retainer Spring	60	532 00 49-29	Rivet Pan Hd Drilled 1/4
16	873 90 06-00	Nut Lock 3/8-16 unc	61	532 12 47-88	Retainer Spring 1"
17	872 14 05-06	Bolt Rdhd Sht Sqnk 5/16 -18 unc x 3/4	62	532 42 82-39	Actuator Elec
19	873 90 05-00	Nut Lock Hex Flange 5/16-18	63	532 42 82-38	Bracket Asm. Lower
20	532 18 88-47	Bracket Pivot RH	64	532 42 96-64	Bracket Mtg. Upper Left
21	532 40 61-80	Bag Asm CRD	65	532 42 96-65	Bracket Mtg. Upper Right
22	532 42 82-36	Bracket Side Bagger	66	532 43 04-24	Plug Bagger
24	532 16 57-83	Tube Pivot Bagger CRD	69	532 43 56-11	Washer .125
25	532 19 37-05	Tube Front Bagger	70	532 43 56-03	Rivet Pop .125 x .750
33	532 42 86-83	Plug Mulcher	71	532 43 83-13	Actuator Support Brkt.
34	532 16 55-70	Handle Mulcher			
35	532 16 55-72	Pin Mulcher			
36	819 13 20-12	Washer 13/32 x 1-1/4 x 12 Ga.			
37	532 17 54-01	Plug Support Bagger CRD			

NOTE: All component dimensions given in U.S. inches
1 inch = 25.4 mm

