

# CTH2642 TE

**Spare parts**

**Ersatzteile**

**Pièces détachées**

**Reserve onderdelen**

**Repuestos**

**Reservdelar**

---

# **ILLUSTRATED PARTS LIST**

**MFG. ID NO. 96061030600**

**CUSTOMER CATALOG NO. CTH2642TE**

**PRODUCT NO. 960 61 03-06**

**TRACTOR - - MODEL NO. CTH2642TE (96061030600), PRODUCT NO. 960 61 03-06  
DECALS 27**

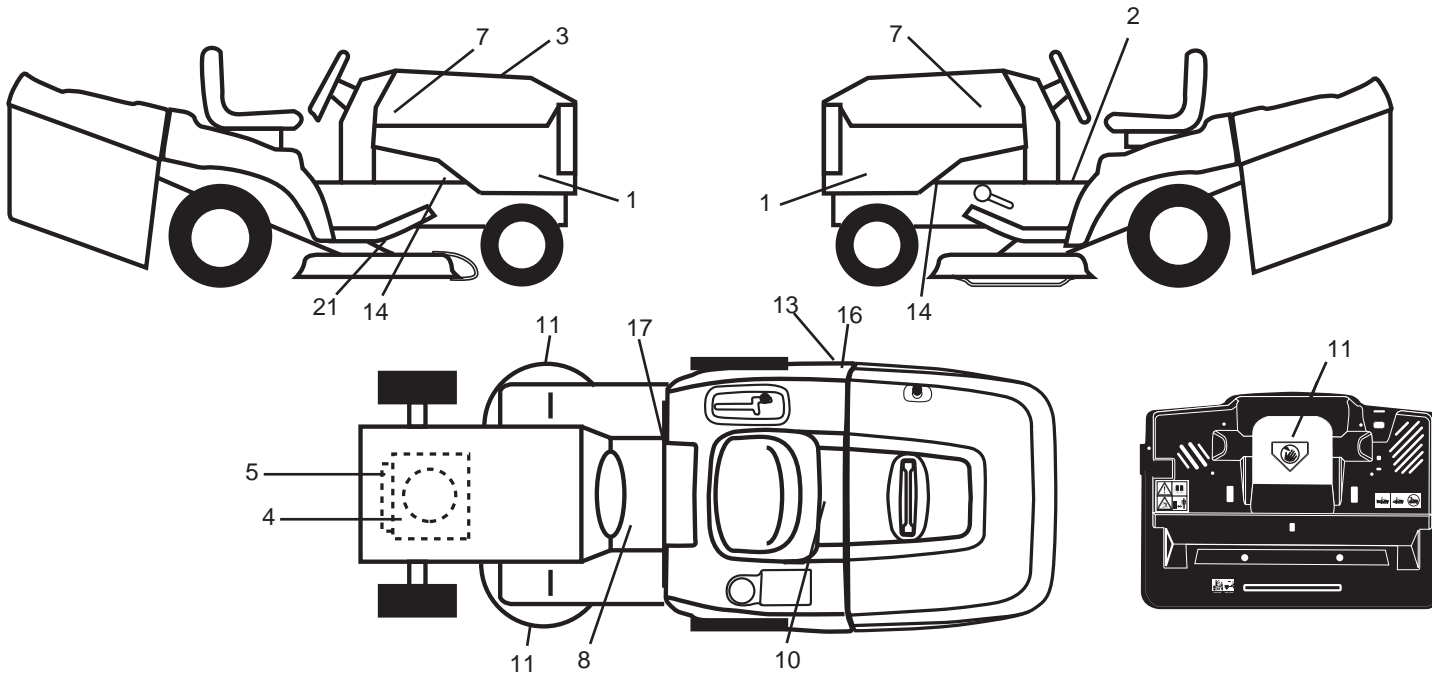

KEY NO.	PART NO.	DESCRIPTION
1	532 43 47-57	Decal, Side Panel
2	532 40 03-89	Decal, Warning Symbols CE
3	532 43 37-82	Decal, Replacement
4	532 19 68-41	Decal, Warning Engine Sym.
5	532 43 29-17	Decal, Engine HP
7	532 42 91-96	Decal, Hood RH/LH Logo
8	532 15 97-37	Decal, Brake/Clutch Symbol
10	532 14 50-05	Decal, Bat Dan/Poi P/L Sym Wpn
11	532 18 21-66	Decal, Mower Cut Finger Symbol
13	532 12 44-33	Decal, 80 DBA

KEY NO.	PART NO.	DESCRIPTION
14	532 15 97-36	Decal, Chassis Hot Muffler
16	532 16 88-69	Decal, Tick Mark
17	532 14 08-37	Decal, Saddle Brake Parking
21	532 16 62-86	Decal, Deck Sch
--	532 16 69-60	Decal, Bypass
--	532 13 83-11	Deck Handle Lift
--	532 18 19-16	Pad Footrest LH
--	532 18 19-17	Pad Footrest RH
--	532 43 45-40	Manual Operator's(English)

**WHEELS & TIRES**

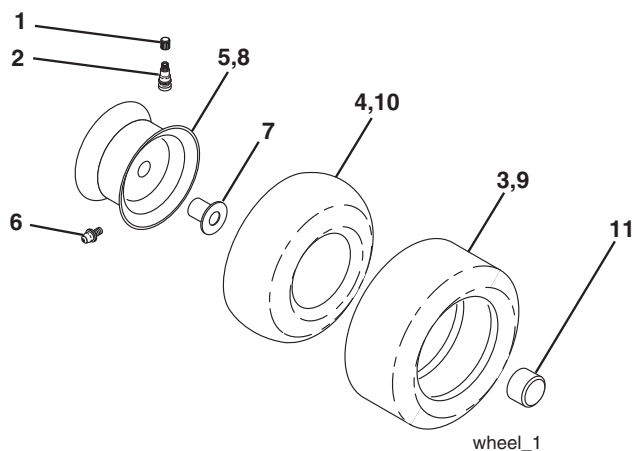

KEY NO.	PART NO.	DESCRIPTION
1	532 05 91-92	Cap Value Tire
2	532 06 51-39	Stem Value
3	532 10 62-22	Tire F Ts 15 x 6 0 - 6 Service
4	532 05 99-04	Tube Inner Front #35060
5	532 13 83-36	Rim Asm 6" Front Service
6	532 12 49-57	Fitting Grease
7	532 12 49-59	Bearing Flange
8	532 13 83-37	Rim Asm 8" Rear Service
9	532 12 20-82	Tire R Ts 20 x 10-8 Service
10	532 12 49-26	Tube Rear 9 5 x 8 Service
11	532 17 50-39	Cap Axle Blk 1 50 x 1 00
--	532 14 43-34	Sealant, Tire (10 oz. tube)

**NOTE:** All component dimensions given in U.S. inches.  
1 inch = 25.4 mm

# TRACTOR - - MODEL NO. CTH2642TE (96061030600), PRODUCT NO. 960 61 03-06

## SCHEMATIC 38

SCH20

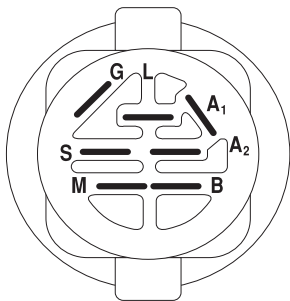
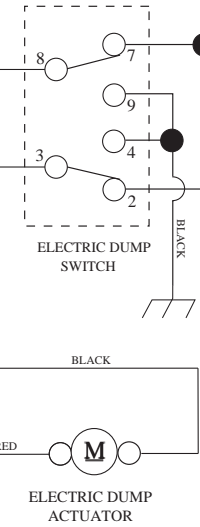
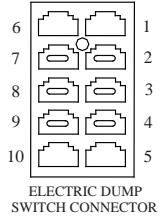
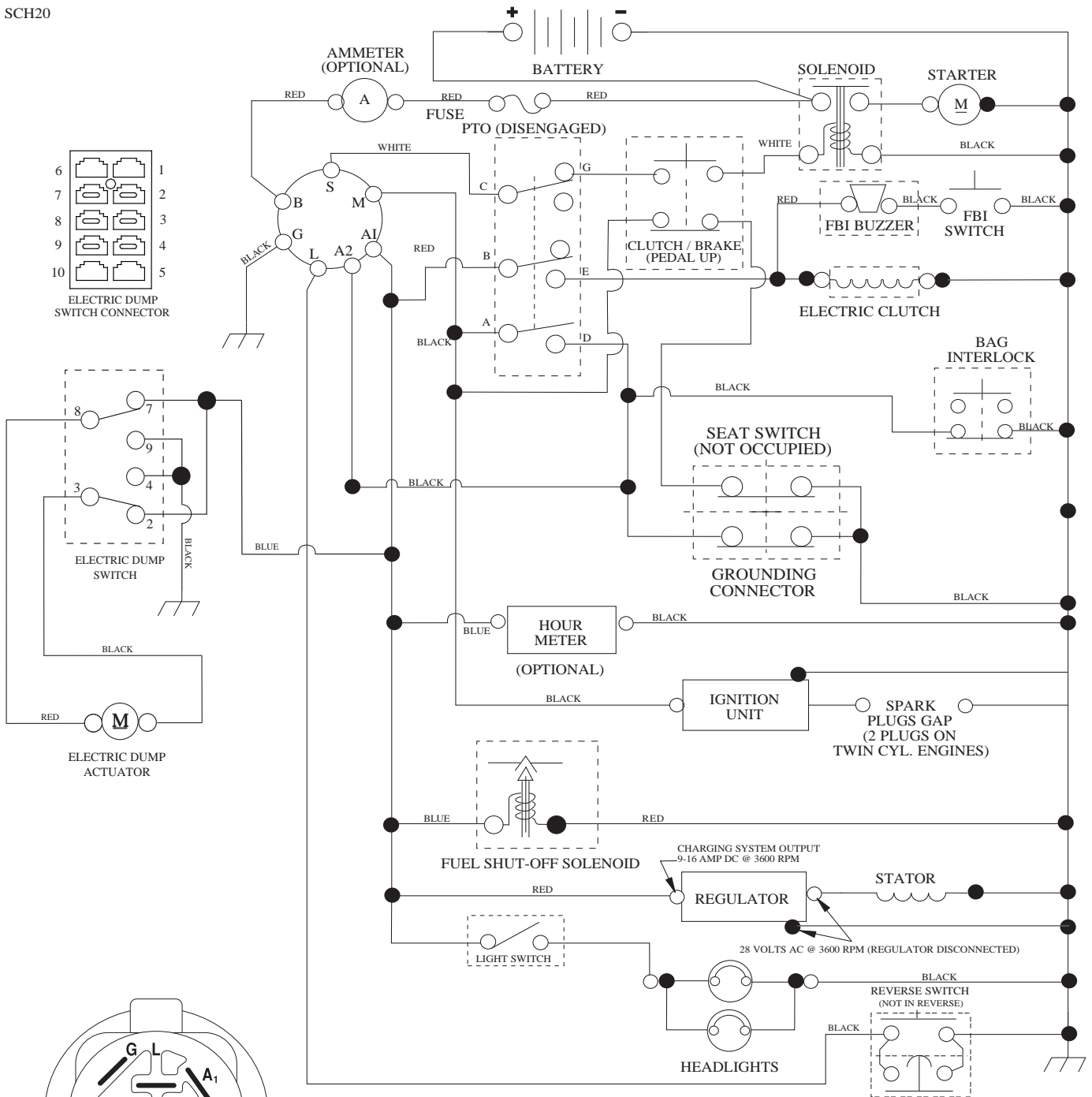

POSITION	CIRCUIT	"MAKE"
OFF	M+G+A1	
RUN/OVERRIDE	B+A1	
RUN	B+A1	L+A2
START	B + S + A1	

03048

WIRING INSULATED CLIPS  
NOTE: IF WIRING INSULATED CLIPS WERE REMOVED FOR SERVICING OF UNIT, THEY SHOULD BE RE-INSTALLED TO PROPERLY SECURE YOUR WIRING.

POSITION	CIRCUIT
OFF	C + G, B + H
ON	C + F, B + E, A + D

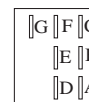
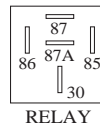

NON-REMOVABLE CONNECTIONS

REMOVABLE CONNECTIONS

**TRACTOR - - MODEL NO. CTH2642TE (96061030600), PRODUCT NO. 960 61 03-06**  
**ELECTRICAL 32**

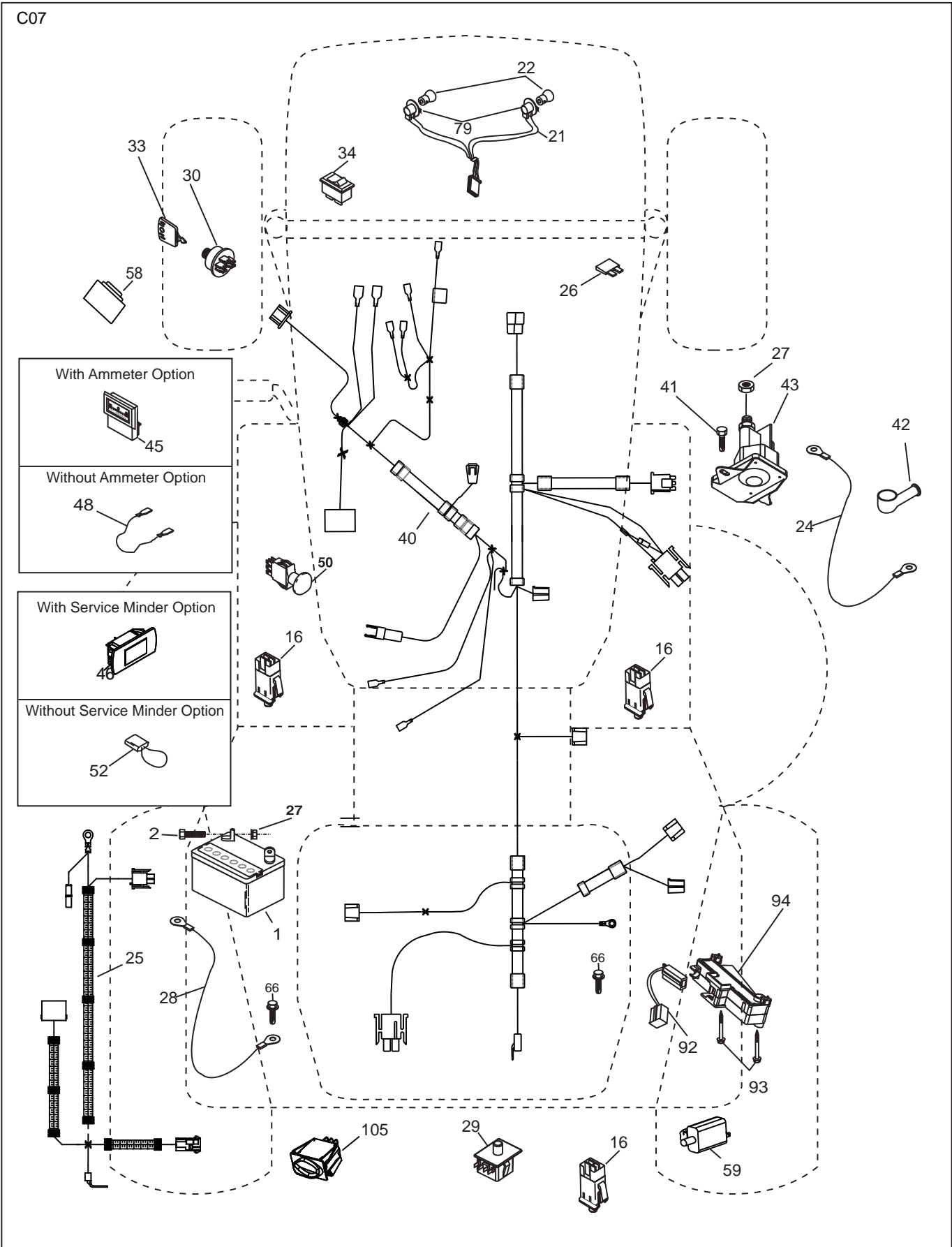

**TRACTOR - - MODEL NO. CTH2642TE (96061030600), PRODUCT NO. 960 61 03-06  
ELECTRICAL 32**

<b>KEY NO.</b>	<b>PART NO.</b>	<b>DESCRIPTION</b>
1	532 16 34-65	Battery
2	874 76 04-12	Bolt Hex Hd 1/4-20 unc x 3/4
16	532 17 61-38	Switch Interlock
21	532 18 37-59	Harness Asm Light w/4152J
22	532 00 41-52	Bulb Light
24	532 42 12-99	Cable Starter 6 Ga. 11" Red
25	532 42 98-69	Cable Battery CRD
26	532 17 51-58	Fuse
27	873 51 04-00	Nut Keps Hex 1/4-20 unc
28	532 12 77-25	Cable Ground 6 Ga. 18" Black
29	532 19 27-49	Switch Seat
30	532 19 33-50	Switch Ignition
33	532 41 19-33	Key/Chain
34	532 11 07-12	Switch Light
40	532 42 98-70	Harness Ign
41	871 11 04-08	Bolt Flk Fin Hex 1/4-20 unc x 1/2
42	532 13 15-63	Cover Terminal Red
43	532 19 25-07	Solenoid
46	532 40 17-63	Gauge Hourmeter
48	532 14 08-44	Adapter Ammeter Rectangular
50	532 17 46-51	Switch PTO
58	532 16 94-19	Buzzer CRD
59	532 18 03-79	Switch FBI CRD
66	817 49 06-08	Screw Thdrol 3/8-16 x 1/2 Ty-Tt
79	532 17 52-42	Socket Asm. Bulb
92	532 19 66-15	Harness Pigtail
93	532 19 25-40	Screw Plastite 10-14 x 2.0
94	532 19 18-34	Module Reverse
105	532 43 04-44	Rotary Switch

**NOTE:** All component dimensions given in U.S. inches.  
1 inch = 25.4 mm.

TRACTOR - - MODEL NO. CTH2642TE (96061030600), PRODUCT NO. 960 61 03-06  
CHASSIS AND ENCLOSURES **39**

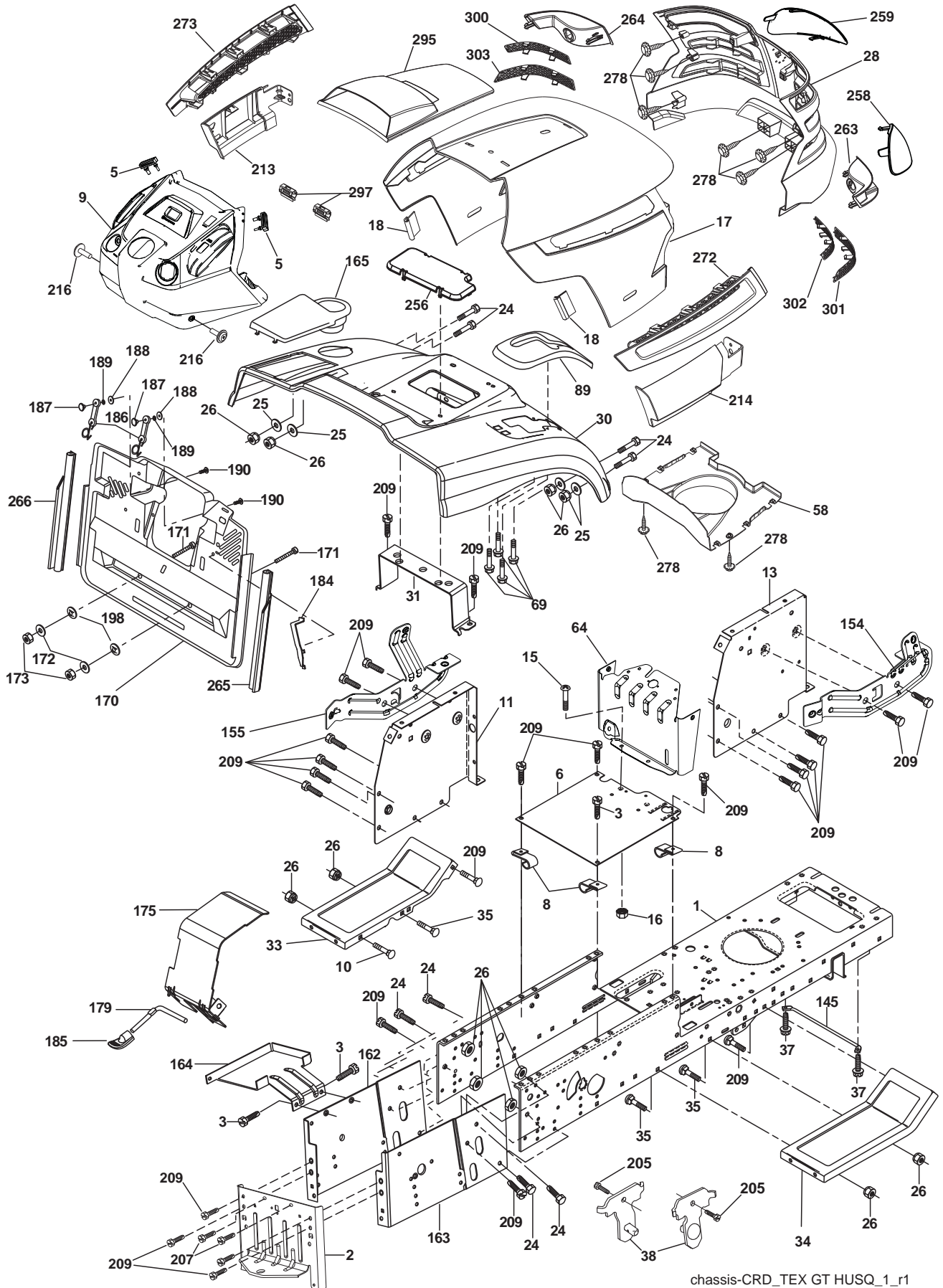

chassis-CRD\_TEX GT HUSQ\_1\_r1

**TRACTOR - - MODEL NO. CTH2642TE (96061030600), PRODUCT NO. 960 61 03-06  
CHASSIS AND ENCLOSURES **39****

KEY NO.	PART NO.	DESCRIPTION	KEY NO.	PART NO.	DESCRIPTION
1	532 17 46-20	Chassis	171	872 14 06-20	Bolt Rdhd Sqnk 3/8-16 x 2-1/2 Gr. 5
2	532 18 03-84	Drawbar	172	819 13 20-16	Washer 13/32 x 1-1/4 x 16 Ga.
3	817 06 06-12	Screw 3/8-16 x 3/4	173	873 51 06-00	Nut, Keps Hex 3/8-16 unc
5	532 40 75-90	Bumper Hood/Dash	175	532 18 82-03	Guard Trap
6	532 18 44-19	Saddle	179	532 18 82-02	Rod Pivot FBI CRD
8	532 12 64-71	Clip Insulator 13/32 Mtg. Hole	184	532 17 46-62	Bracket Actuator Bagger CRD
9	532 40 89-11	Dash Upper	185	532 18 11-01	Knob Rod Brake Parking
10	872 14 06-08	Bolt, Carriage 3/8-16 x 3/4	186	532 16 07-93	Latch Asm Mulch/Bagger
11	532 16 72-03	Panel, Dash, L.H.	187	532 12 50-04	Nut Weld
13	532 17 82-98	Panel, Asm. Dash R.H.	188	819 06 12-16	Washer #10
15	874 18 05-12	Screw, Machine, THD 5/16-18 unc x 3/4	189	810 07 10-00	Washer Lock #10
16	873 51 05-00	Nut Keps 5/16-18 unc	190	871 08 10-10	Screw Pan Hd Phillip 10-24 x 5/8
17	532 41 10-46	Hood	198	532 16 89-37	Nut, Push
18	532 40 47-42	Bumper Hood	205	817 49 06-08	Screw Thdrol 3/8-16 x 1/2
24	874 78 06-16	Bolt	207	817 67 05-08	Screw Thdrol 5/16-18 x 1/2
25	819 13 13-12	Washer 13/32 x 13/16 x 12 Ga.	209	817 00 06-12	Screw Hex Wsh Thdrol 3/8-16
26	873 80 06-00	Nut	213	532 40 17-11	Skirt Side LH
28	532 40 86-07	Grille /Lens Asm	214	532 40 17-09	Skirt Side RH
30	532 19 73-76	Fender	216	817 06 04-10	Hex Tapping Screw
31	532 16 51-56	Bracket, Fender Support	256	532 18 13-61	Cover Fender Rack
33	532 18 10-57	Footrest, L.H.	258	532 19 89-06	Lens RH
34	532 18 10-58	Footrest, R.H.	259	532 19 89-07	Lens LH
35	872 11 06-06	Bolt	263	532 19 71-98	Bezel RH
37	817 49 05-08	Screw Thdrol 5/16-18 x 1/2 TYT	264	532 19 71-99	Bezel LH
38	532 18 17-48	Bracket Asm Pivot Mower Rear	265	532 18 57-04	Seal RH Side Bagger
58	532 19 85-12	Duct Air	266	532 18 57-03	Seal LH Side Bagger
64	532 19 93-95	Dash Lower	272	532 40 30-48	Vent Hood RH
69	532 14 24-32	Screw Hx Wsh Hi-Lo 1/4-1/2	273	532 40 30-76	Vent Hood LH
89	532 19 73-77	Console CRD Auto Grey	278	532 41 63-58	Screw #10 x 0.750 BOS Thread
145	532 40 91-67	Rod Pivot Chassis/Hood	295	532 41 66-13	Vent Top Hood
154	532 40 86-90	Bracket Mounting Dash RH	297	532 19 91-45	Clip Retainer Tinner
155	532 40 86-91	Bracket Mounting Dash LH	300	532 19 91-31	Insert Tex Top LH
162	532 18 03-82	Bracket Exten Chassis LH CRD	301	532 19 91-30	Insert Tex Top RH
163	532 18 03-83	Bracket Exten Chassis RH CRD	302	532 19 91-32	Insert Tex Bottom RH
164	532 16 56-05	Support Battery CRD	303	532 19 91-33	Insert Tex Bottom LH
165	532 43 22-76	Cover Battery			
170	532 19 94-88	Backplate CRD			

**NOTE:** All component dimensions given in U.S. inches.  
1 inch = 25.4 mm.



TRACTOR - - MODEL NO. CTH2642TE (96061030600), PRODUCT NO. 960 61 03-06  
DRIVE **40**

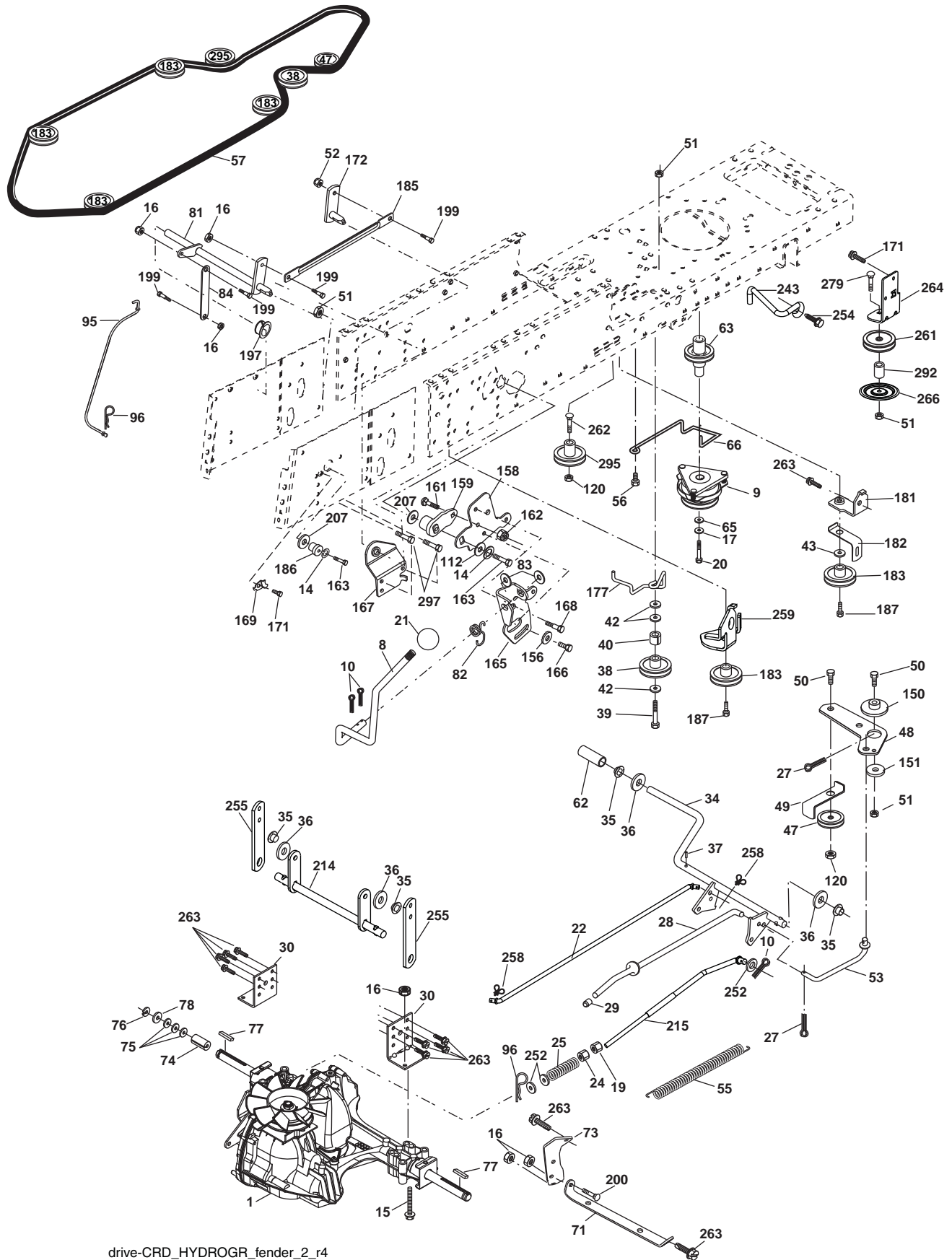

drive-CRD\_HYDROGR\_fender\_2\_r4

**TRACTOR - - MODEL NO. CTH2642TE (96061030600), PRODUCT NO. 960 61 03-06  
DRIVE **40****

KEY NO.	PART NO.	DESCRIPTION	KEY NO.	PART NO.	DESCRIPTION
1	-----	Transaxle Hydro Gear 321-0510	95	532 17 00-15	Control Asm Bypass Hydro
8	532 19 27-06	Rod, Shift Fender Adjust Lt	96	532 12 47-88	Spring, Retainer 1"
9	532 19 81-43	Clutch Electric	112	819 09 12-10	Washer 9/32 x 3/4 x 10 Ga.
10	876 02 04-16	Pin, Cotter 1/8 x 1	120	873 90 06-00	Nut Lock Flg. 3/8-16 unc
14	810 04 04-00	Washer, Lock Hvy Helical	150	532 16 58-50	Bushing, Bellcrank Grnd Dr
15	874 49 05-44	Bolt Hex FGHD 5/16-18 x Gr. 5	151	819 13 32-10	Washer 13/32 x 2 x 10 Ga.
16	873 80 05-00	Nut Lock Hex w/lns 5/16-18 unc	156	532 16 60-02	Washer Srrted 5/16 ID x 1.125
17	532 12 61-97	Washer 1-1/2 x 15/32 x .250	158	532 16 55-89	Bracket Shift Mount
19	873 80 06-00	Nut Lock Hex w/lns 3/8-16 unc	159	532 18 39-00	Hub Shift
20	532 17 39-37	Bolt Hex 7/16-20 x 4 Gr. 5	161	872 14 04-06	Bolt Rdhd Sqnk 1/4-20 x 3/4 Gr. 5
21	532 12 12-74	Knob Duckhead 1/4-13 unc Blk	162	873 68 04-00	Nut Crownlock 1/4-20 unc
22	532 17 56-07	Rod Brake Main	163	874 78 04-16	Bolt Hex Fin 1/4-20 unc x 1 Gr. 5
24	873 35 06-00	Nut Hex Jam 3/8-16 unc	165	532 16 56-23	Bracket Pivot Lever
25	532 19 20-36	Spring, Rod, Brake	166	817 49 05-10	Screw 5/16-18 x 5/8
27	876 02 04-12	Pin, Cotter 1/8 x 3/4	167	532 16 55-88	Bracket Support Shift CRD
28	532 17 57-65	Rod, Parking Brake	168	532 16 54-92	Bolt Shoulder 5/16-18 x .561
29	532 07 16-73	Cap, Parking Brake	169	532 16 55-80	Plate Fastening Lt
30	532 16 95-92	Bracket, Mfg. Transaxle	171	817 49 06-08	Screw Thdrol 3/8-16 x 1/2 Ty-Tt
34	532 17 55-78	Shaft, Asm Pedal Foot CRD	172	532 17 02-71	Shaft Asm Shifter Frt CRD
35	532 12 01-83	Bearing, Nylon	177	532 16 59-32	Keeper Flat Idler 3.06" CRD
36	819 21 16-16	Washer 21/32 x 1 x 16 Ga.	181	532 18 02-11	Bracket Idler Ground Drive CRD
37	532 12 49-63	Pin, Roll 3/16 x 1"	182	532 18 26-82	Keeper Belt 2.5" Od V-Idler CRD
38	532 16 59-36	Pulley Flat Composite 3.06"	183	532 19 95-34	Pulley V-Idler
39	874 76 06-44	Bolt Fin Hex 3/8-16 unc x 2-3/4	185	532 17 00-08	Link Shift
40	532 12 49-65	Spacer, Split 395 x 59 Bzp	186	532 16 56-14	Hub Tapered Round CRD
42	819 13 13-12	Washer 13/32 x 13/16 x 12 Ga.	187	817 58 05-20	Screw Thdrol 5/16-18 x 1.25
43	819 11 10-12	Washer 11/32 x 5/8 x 12 Ga.	197	532 16 96-13	Nyliner Snap-In 5/8
47	532 12 77-83	Pulley, Idler, V Groove Plasic	199	532 16 96-12	Bolt Shoulder 5/16-18 unc
48	532 15 44-07	Bellcrank Clutch Grnd Drv	200	872 14 05-08	Bolt RDHD SQNK 5/16-18 x 1
49	532 12 32-05	Retainer, Belt Style Spring	207	532 16 98-45	Washer Nylon Rear
50	872 11 06-12	Bolt Carr. Sh. 3/8-16 x 1-1/2 Gr. 5	214	532 17 56-09	Shaft Asm. Brake
51	873 68 06-00	Nut, Crownlock 3/8-16 unc	215	532 17 56-52	Rod Brake Hydro
52	873 68 05-00	Nut Crownlock 5/16-18	243	532 19 07-36	Bracket Anti Rotation
53	532 19 96-52	Link, Clutch 7.66	252	819 13 16-16	Washer 13/32 x 1 x 16 Ga.
55	532 10 57-09	Spring, Return, Clutch	254	817 00 06-16	Screw 3/8-16 x 1
56	817 06 06-20	Screw 3/8-16 x 1-1/4	255	532 17 56-08	Brace Shaft Brake Mtg.
57	532 17 01-40	V-Belt Kev 112" 0650 CRD	258	532 17 80-62	Clip Retainer
62	532 12 48-72	Cover, Pedal	259	532 18 02-12	Bracket Pulley
63	532 18 03-97	Pulley Engine	260	532 43 11-72	Bracket Idler Chassis
65	810 04 07-00	Washer	261	532 13 14-94	Pulley Idler
66	532 15 47-78	Keeper, Belt Engine F-Proof	262	872 11 06-22	Bolt Carr. 3/8-16 x 2-3/4 Gr.5
71	532 16 91-83	Strap, Torque, LH	263	817 00 06-12	Screw 3/8-16 x 3/4
73	532 16 91-82	Strap, Torque, RH	266	532 18 20-61	Shield Idler Mower
74	532 13 70-57	Spacer, Split	279	872 11 06-16	Bolt 3/8-16 unc x 2
75	532 12 17-49	Washer 25/32 x 1-1/4 x 16 Ga.	292	532 40 02-71	Spacer
76	812 00 00-01	Ring, E	295	532 17 91-14	Pulley Idler Composite
77	532 12 35-83	Key, Square	297	817 49 06-10	Screw 3/8-16 x 5/8
78	532 12 17-48	Washer 25/32 x 1-5/8 x 16 Ga.			
81	532 17 00-06	Asm, Shaft,Cross Rear			
82	532 16 57-11	Spring, Torsion			
83	819 17 12-16	Washer 17/32 x 3/4 x 16 Ga.			
84	532 17 00-07	Link, Transaxle			

**NOTE:** All component dimensions given in U.S. inches  
1 inch = 25.4 mm

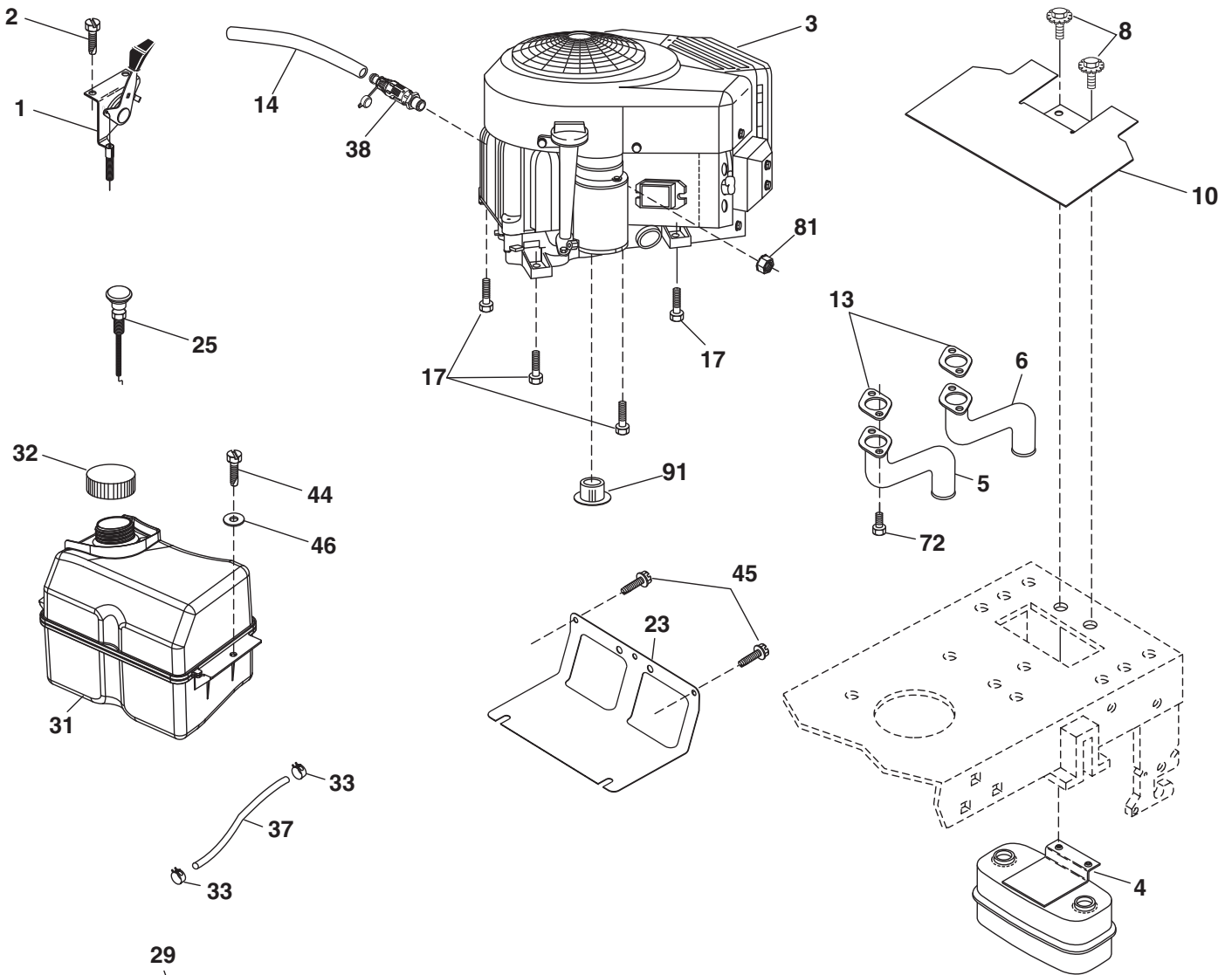

**OPTIONAL EQUIPMENT**  
**Spark Arrester**

Engine-CRD\_bs-2cyl\_7

**TRACTOR - - MODEL NO. CTH2642TE (96061030600), PRODUCT NO. 960 61 03-06  
ENGINE 24**

KEY NO.	PART NO.	DESCRIPTION
1	532 17 83-85	Control Throt
2	532 41 63-58	Screw #10 x 0.750 BOS Thread
3	-----	Engine B&S Model No. 44P777-1455-B1
4	532 14 97-23	Muffler Exhaust
5	532 15 99-55	Tube, Exhaust LH
6	532 16 05-89	Tube, Exhaust RH
8	532 17 18-77	Bolt 5/16-18 x 3/4
10	532 43 40-17	Shield Heat Muffler
13	532 16 53-91	Gasket
14	532 14 84-56	Tube Drain Oil Easy
17	817 06 06-20	Screw 3/8-16 x 1 1/4
23	532 16 98-37	Shield Browning/Debris Guard
25	532 19 15-96	Choke Control
29	532 13 71-80	Arrestor Spark
31	532 40 74-89	Tank Fuel
32	532 43 02-20	Cap Asm Fuel
33	532 12 34-87	Clamp Hose Blk
37	532 13 70-40	Line Fuel 20"
38	532 42 82-87	Valve Oil Drain
44	817 67 04-12	Screw Hexwsh Thdrol 1/4-20 x 3/4
45	817 00 06-12	Screw Hexwsh Thdr 3/8-16 x 3/4
46	819 09 14-16	Washer 9/32 x 7/8 x 16 Ga.
72	532 18 39-06	Screw Socket HD 5/16-18 x 1
81	873 51 04-00	Nut Keps 1/4-20 unc
91	532 18 74-95	Bushing 1.375 OD Heyco 2210

**NOTE:** All component dimensions given in U.S. inches  
1 inch = 25.4 mm

**Engine Power Rating Information**

The gross power rating for individual gas engine models is labeled in accordance with SAE (Society of Automotive Engineers) code J1940 (Small Engine Power & Torque Rating Procedure), and rating performance has been obtained and corrected in accordance with SAE J1995 (Revision 2002-05). Torque values are derived at 3060 RPM; horsepower values are derived at 3600 RPM. Actual gross engine power will be lower and is affected by, among other things, ambient operating conditions and engine-to-engine variability. Given both the wide array of products on which engines are placed and the variety of environmental issues applicable to operating the equipment, the gas engine will not develop the rated gross power when used in a given piece of power equipment (actual "on-site" or net power). This difference is due to a variety of factors including, but not limited to, accessories (air cleaner, exhaust, charging, cooling, carburetor, fuel pump, etc.), application limitations, ambient operating conditions (temperature, humidity, altitude), and engine-to-engine variability. Due to manufacturing and capacity limitations, Briggs & Stratton may substitute an engine of higher rated power for this Series engine.

TRACTOR - - MODEL NO. CTH2642TE (96061030600), PRODUCT NO. 960 61 03-06  
 STEERING ASSEMBLY **41**

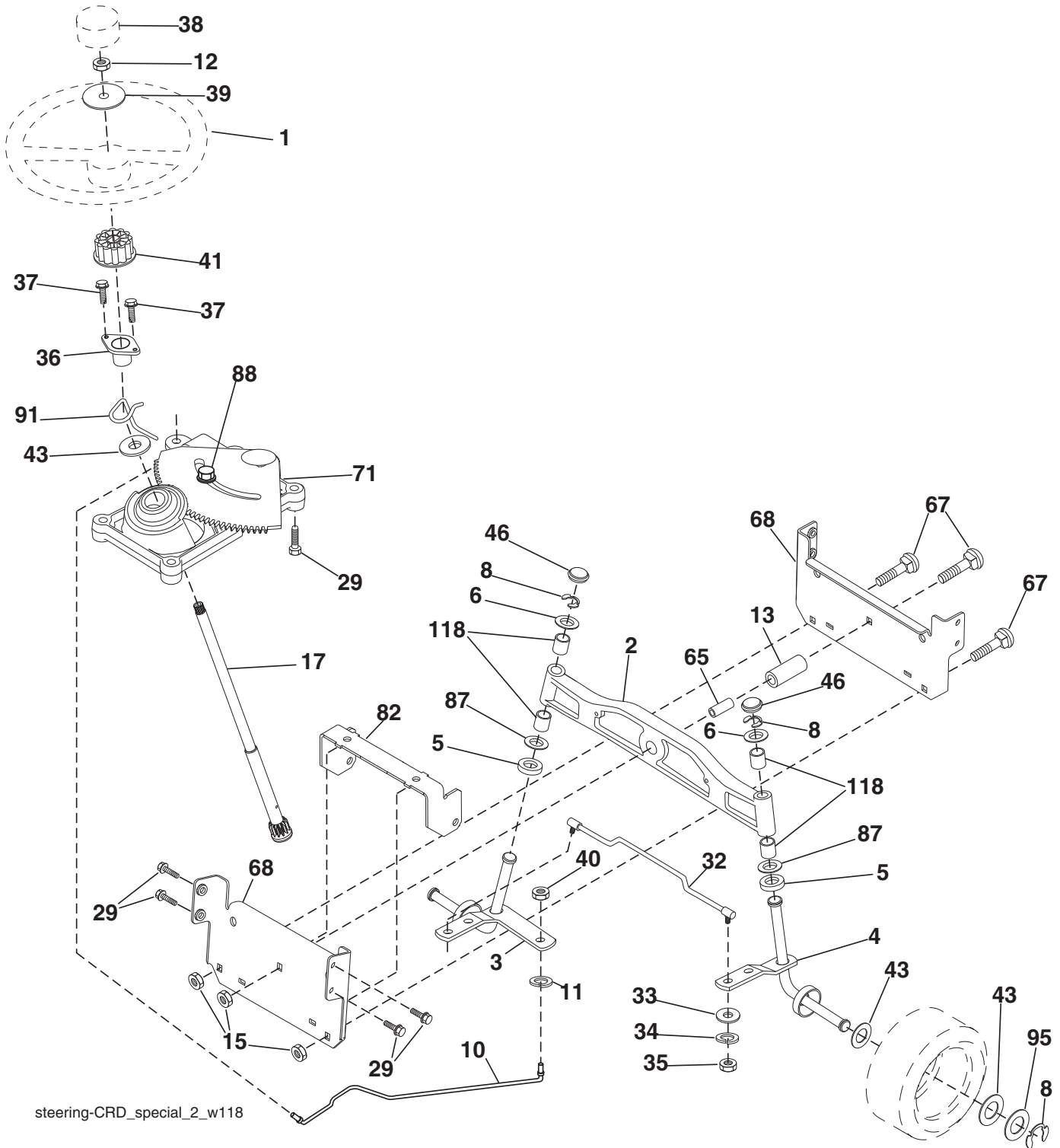

**TRACTOR - - MODEL NO. CTH2642TE (96061030600), PRODUCT NO. 960 61 03-06  
STEERING ASSEMBLY **41****

<b>KEY NO.</b>	<b>PART NO.</b>	<b>DESCRIPTION</b>
1	532 41 64-80	Steering Wheel
2	532 19 35-42	Axle Asm Cast Iron Lt
3	532 16 98-40	Spindle Assembly, L.H.
4	532 16 98-39	Spindle Assembly, R.H.
5	532 12 49-31	Bearing, Race, Thrust, Hardened
6	532 12 17-48	Washer 25/32 x 1-5/8 x 16 Ga.
8	812 00 00-29	Ring, Klip
10	532 17 51-21	Link, Drag
11	810 04 06-00	Washer, Lock
12	873 94 08-00	Nut Hex Jam Toplock 1/2-20 unf
13	532 13 65-18	Spacer Brg Axle Front
15	873 90 06-00	Nut Lock Flg 3/8-16
17	532 17 78-83	Shaft, Steering
29	817 00 06-12	Screw 3/8-16 x 3/4
32	532 17 18-88	Rod, Tie
33	819 11 12-16	Washer 11/32 x 3/4 x 16 Ga.
34	810 04 05-00	Washer Lock Hvy Hlcl Spr 5/16
35	873 54 05-00	Crownlock Nut 5/16-24 unf 3847
36	532 15 51-05	Bushing, Steering
37	532 15 29-27	Screw TT #10-32 x 5 x 3/8 Flange
38	532 41 59-87	Cap Wheel Steering
39	819 18 38-12	Washer 9/16 ID x 2- 3/8 OD x 12 Ga.
40	873 54 06-00	Nut Lock 3/8-24
41	532 18 67-37	Adaptor, Steering Wheel
43	532 12 17-49	Washer 25/32 x 1-1/4 x 16 Ga.
46	532 12 12-32	Cap, Spindle
65	532 41 47-36	Spacer Brace Axle
67	872 11 06-18	Bolt Rdhd Sqnk 3/8-16 x 2-1/4
68	532 16 98-27	Brace Axle
71	532 17 51-46	Steering Asm.
82	532 19 99-78	Bracket Susp Chassis Front
87	532 17 39-66	Washer Flat .781 x 1 1/2 x .14
88	532 17 51-18	Bolt Shoulder 7/16-20 unc
91	532 17 55-53	Clip Steering
95	532 18 89-67	Washer
118	532 40 60-13	Bushing

**NOTE:** All component dimensions given in U.S. inches.  
1 inch = 25.4 mm.

TRACTOR - - MODEL NO. CTH2642TE (96061030600), PRODUCT NO. 960 61 03-06  
 MOWER DECK **44**

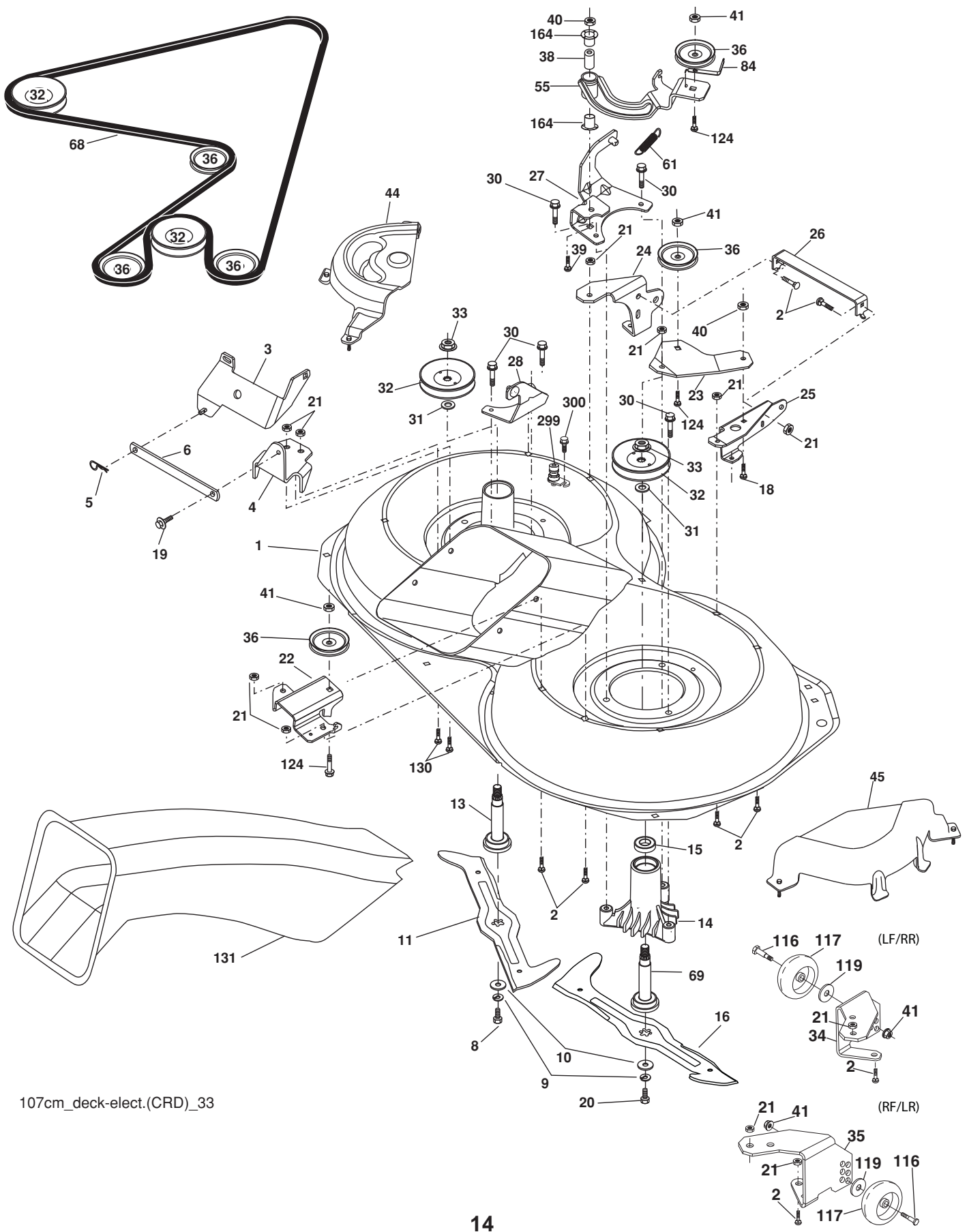

107cm\_deck-elect.(CRD)\_33

**TRACTOR - - MODEL NO. CTH2642TE (96061030600), PRODUCT NO. 960 61 03-06  
MOWER DECK 44**

KEY NO.	PART NO.	DESCRIPTION	KEY NO.	PART NO.	DESCRIPTION
1	532 44 29-26	Housing Asm. Mower 107 CRD	39	872 11 06-22	Bolt Rdhd 3/8-16 unc x 2-3/4 Gr. 5
2	872 14 05-06	Bolt Rdhd Sqnk 5/16-18 unc x 3/4	40	873 68 06-00	Nut Crownlock 3/8-16 unc
3	532 43 18-64	Bracket Asm. S-Bar Chass	41	873 90 06-00	Nut Flangelock 3/8-16 unc
4	532 16 91-67	Bracket Bar Sway Deck 107 CRD	44	532 43 27-73	Cover Mandrel LH 107 CRD
5	532 12 46-70	Retainer Spring	45	532 43 27-72	Cover Mandrel RH 107 CRD
6	532 16 55-57	Bar Sway CRD	55	532 16 98-49	Arm Idler 107 CRD
8	532 18 17-12	Bolt 3/8-24 x 1.25 Gr. 8 Patched	61	532 19 94-87	Spring Tension Belt
9	810 03 06-00	Washer Lock Hvy 3/8 Unplated	68	532 40 20-09	Belt
10	532 14 02-96	Washer Hardened	69	532 16 54-82	Shaft Asm w/Lwr Brg RH Thd CRD
11	532 18 05-83	Blade 3-1 LH 107 CRD	84	532 15 60-85	Keeper Belt Idler
13	532 13 76-45	Shaft Asm. w/Lower Bearing	116	532 19 34-06	Bolt Shoulder
14	532 12 87-74	Housing Mandrel Vented (Machd)	117	532 17 48-73	Wheel Gage Donut Wide
15	532 11 04-85	Bearing Ball Mandrel	119	819 13 20-12	Washer 13/32 x 1-1/4 x 12
16	532 18 05-84	Blade 3-1 RH 107 CRD	124	872 11 06-12	Bolt Carr Sh 3/8-16 x 1-1/2 Gr. 5
18	872 11 06-06	Bolt RdHd Sqnk 3/8-16 x 3/4	130	872 11 05-06	Bolt Rdhdsqnk 5/16-18 unc x 3/4
19	532 13 28-27	Bolt Shoulder 5/16-18 Thd Form	131	532 16 56-61	Chute Bagger CRD 107 cm
20	532 18 17-13	Bolt 3/8-24 x 1.25 Gr. 8 Ptch Lhthd	164	532 12 49-37	Bearing Col. Strg.
21	873 68 05-00	Nut Crown Lock 5/16-18	299	532 41 55-98	Port Washout
22	532 16 91-65	Bracket Idler Sprr RR 107 CRD	300	532 15 29-27	Screw TT #10-32.5 3/8 Flange
23	532 16 91-66	Bracket Idler Sprr RF 107 CRD	--	532 13 07-94	Mandrel Assembly (Includes housing, shaft assembly, and bearing only - pulley/nut/washer and blade bolt/washers not included)
24	532 41 34-36	Bracket Suspension LF 107 CRD	--	532 16 55-79	Mandrel Asm CRD LH Threads SVC
25	532 40 01-05	Bracket Suspension RF 107 CRD	--	532 43 47-18	Replacement Mower Complete
26	532 40 01-10	Brace Support Susp Frr CRD			
27	532 16 91-72	Bracket Asm. Susp RR 107 CRD			
28	532 16 91-68	Bracket Asm. Susp LR 107 CRD			
30	532 17 39-84	Screw Thd Rolling Hex			
31	532 18 76-90	Washer Spacer			
32	532 19 81-45	Mandrel Pulleys			
33	532 40 02-34	Nut Flg Top Lock			
34	532 40 01-03	Bracket Gauge Wheel LF/RR			
35	532 40 01-04	Bracket Gauge Wheel RF/LR			
36	532 14 67-63	Pulley Idler V-Groove Dim 4.25			
38	532 16 98-51	Spacer Hub Arm Idler 107 CRD			

**NOTE:** All component dimensions given in U.S. inches  
1 inch = 25.4 mm



**TRACTOR - - MODEL NO. CTH2642TE (96061030600), PRODUCT NO. 960 61 03-06**  
**MOWER LIFT 45**

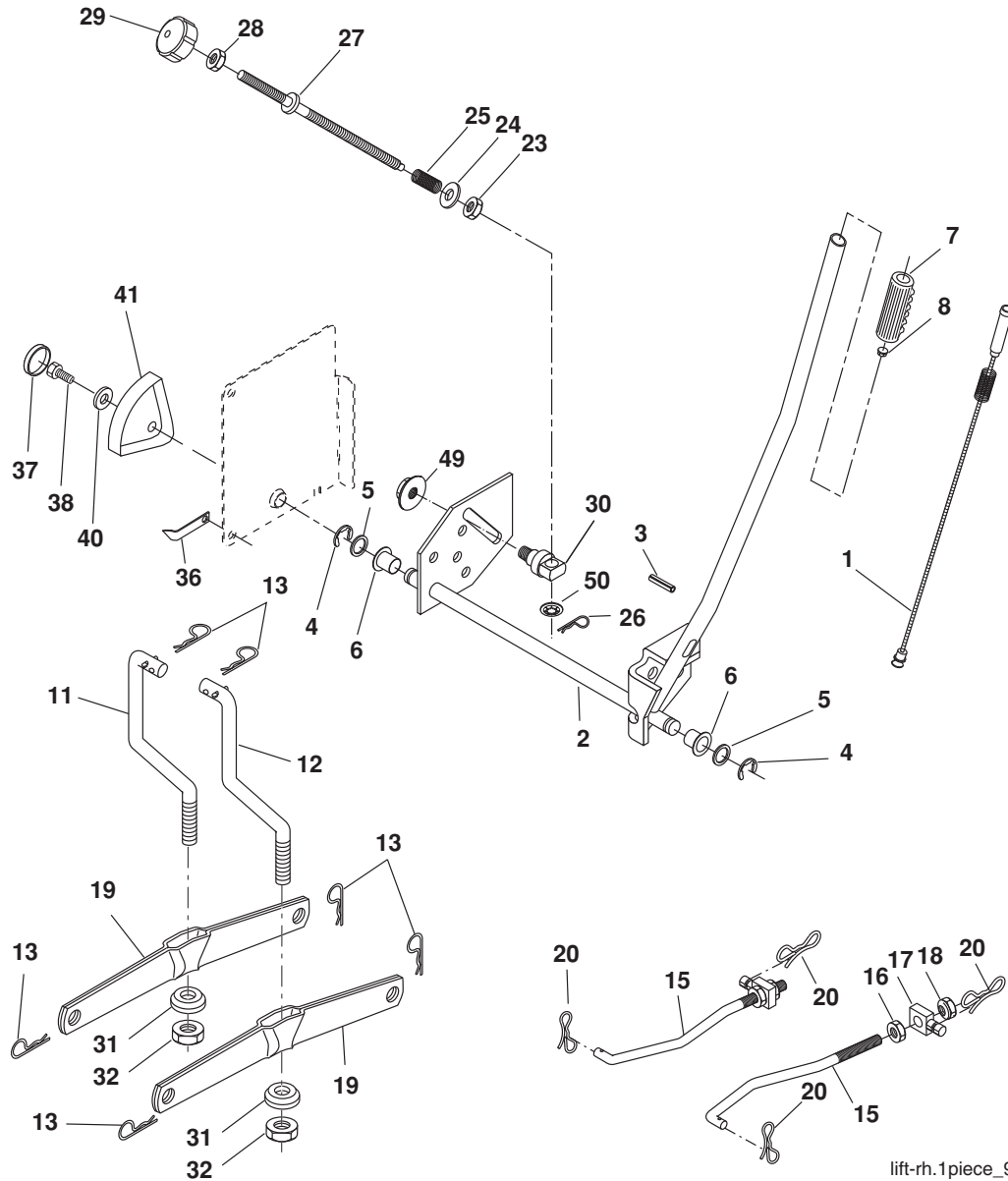

lift-rh.1piece\_9

KEY NO.	PART NO.	DESCRIPTION
1	532 40 50-07	Plunger Asm. Lift
2	532 19 80-70	Wire Asm Inner Spring w/Plunger
3	532 18 88-22	Pin Groove
4	812 00 00-02	E Ring #5133-62
5	819 21 16-21	Washer 21/32 x 1 x 21 Ga.
6	532 12 01-83	Bearing Nylon
7	532 12 56-31	Grip Handle
8	532 12 45-26	Button Plunger Black
11	532 16 58-29	Link Lift L.H.
12	532 16 58-31	Link Lift R.H.
13	532 12 46-70	Retainer Spring
15	532 17 32-88	Link Front
16	873 35 08-00	Nut Jam Hex 1/2-13 unc
17	532 17 56-89	Trunnion
18	873 80 08-00	Nut Lock w/Wsh 1/2-13 unc
19	532 13 98-68	Arm Suspension Mower
20	532 19 42-09	Pin Cotter 7/16 Bow Tie Lock
23	532 11 08-07	Nut Special

KEY NO.	PART NO.	DESCRIPTION
24	819 13 10-16	Washer 13/32 x 5/8 x 16 Ga.
25	532 16 40-24	Spring 2-1/8
26	532 16 94-84	Retainer Clip
27	532 16 45-43	Rod Adj Lift Zinc
28	873 35 06-00	Nut Hex Jam 3/8-16 unc
29	532 13 80-57	Knob Inf 3/8-16 unc
30	532 15 02-33	Trunnion Infin Height
31	532 16 98-65	Bearing, Pvt. Lift.
32	873 54 06-00	Nut Crownlock 3/8-24
36	532 15 50-97	Pointer Height Indicator
37	532 12 39-35	Plug Hole Blk
38	817 06 05-16	Screw 5/16-18 x 1
40	819 11 24-10	Washer 11/32 x 1-1/2 x 10 Ga.
41	532 12 39-34	Scale Ind Height Blk
49	532 14 52-12	Nut Hex Flange Lock
50	532 11 04-52	Nut Push Phos/Oil

**NOTE:** All component dimensions given in U.S. inches  
 1 inch = 25.4 mm

**TRACTOR - - MODEL NO. CTH2642TE (96061030600), PRODUCT NO. 960 61 03-06  
SEAT ASSEMBLY 42**

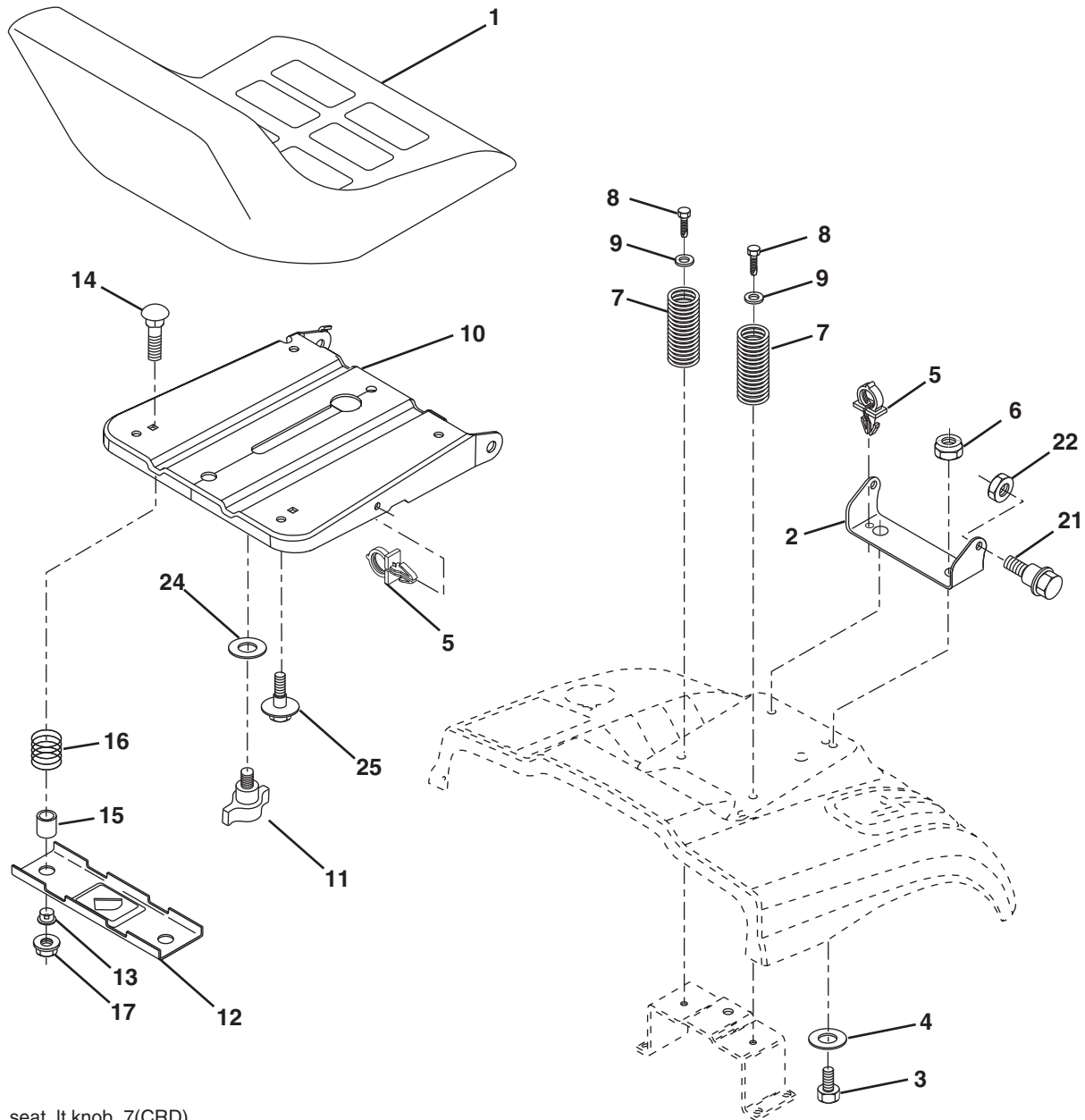

seat\_lt.knob\_7(CRD)

KEY NO.	PART NO.	DESCRIPTION
1	532 18 87-15	Seat
2	532 14 05-51	Bracket Pnt Pivot Seat (Blk )
3	871 11 06-16	Bolt Fin Hex 3/8-16 x 1
4	819 13 16-10	Washer Flat 13/32 x 1 x 10 Ga.
5	532 14 50-06	Clip Push In Hinged
6	873 80 06-00	Nut Lock Hx w/Ins. 3/8-16
7	532 12 41-81	Spring Seat Cprsn 2 250 Blk Zi
8	817 00 06-16	Screw 3/8-16 x 1-1/2
9	819 13 16-14	Washer 13/32 x 1 x 14 Ga.
10	532 19 55-30	Pan Pnt Seat
11	532 16 63-69	Knob Seat Adj. Wingnut
12	532 17 46-48	Bracket Pnt Mounting Switch

KEY NO.	PART NO.	DESCRIPTION
13	532 12 12-48	Bushing Snap Blk Nyl 50 Id
14	872 05 04-12	Bolt Rdhd Sht Nk 1/4-20 x 1-1/2
15	532 12 12-49	Spacer Split
16	532 12 37-40	Spring Cprsn Plate
17	532 12 39-76	Nut Lock 1/4 Lge Flg Gr 5 Zinc
21	532 17 18-52	Bolt Shoulder 5/16-18 unc-2A
22	873 80 05-00	Nut Hex Lock w/Ins 5/16-18
24	819 17 19-12	Washer 17/32 x 1-3/16 x 12 Ga.
25	532 12 70-18	Bolt Shoulder 5/16-18 x 62

**NOTE:** All component dimensions given in U.S. inches.  
1 inch = 25.4 mm

TRACTOR - - MODEL NO. CTH2642TE (96061030600), PRODUCT NO. 960 61 03-06  
BAGGER **46**

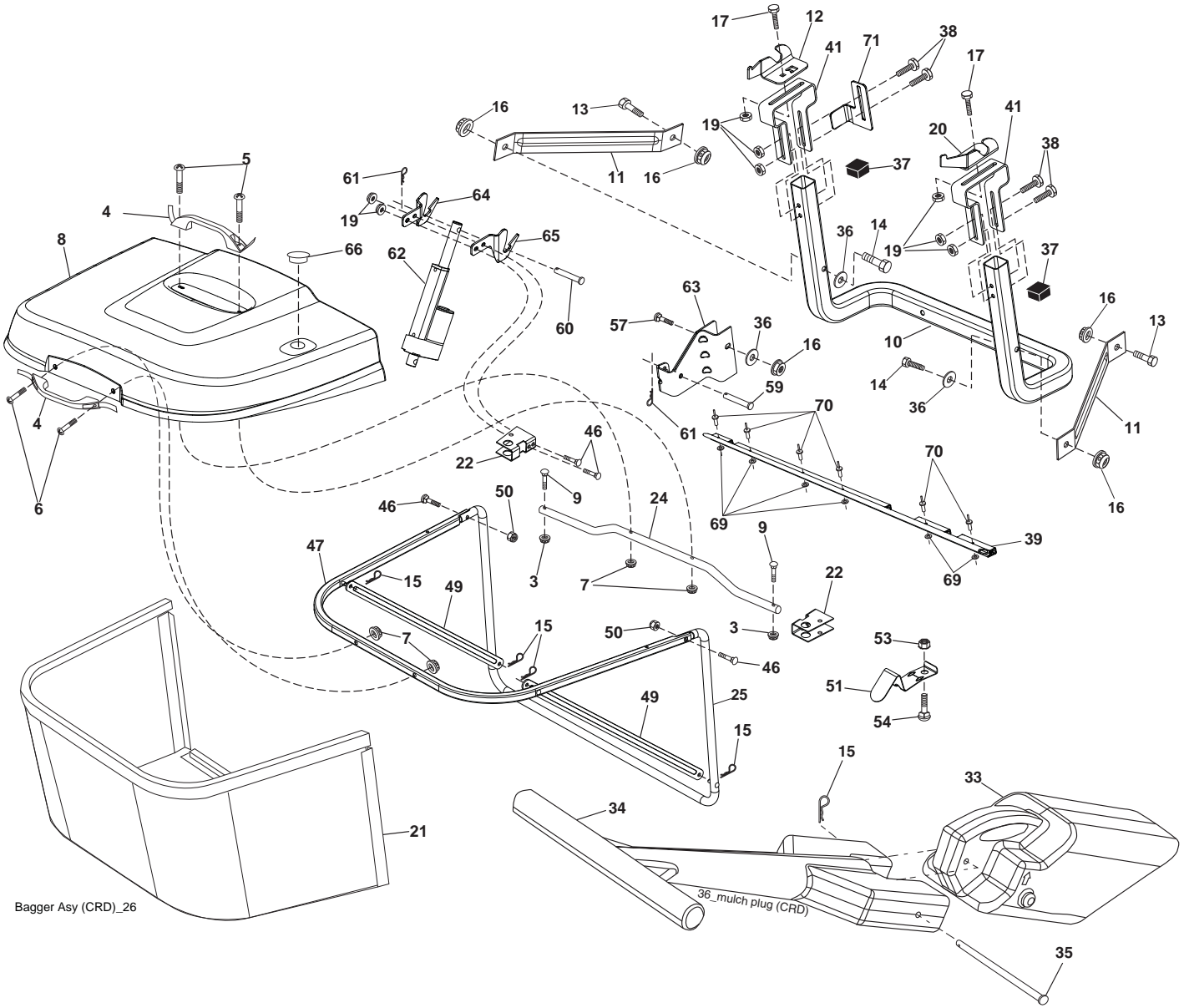

Bagger Asy (CRD)\_26

**TRACTOR - - MODEL NO. CTH2642TE (96061030600), PRODUCT NO. 960 61 03-06  
BAGGER 46**

KEY NO.	PART NO.	DESCRIPTION	KEY NO.	PART NO.	DESCRIPTION
3	532 12 39-76	Nut Lock 1/4 Lge Flg Gr. 5 Zinc	37	532 17 54-01	Plug Support Bagger CRD
4	532 16 99-16	Handle Bagger w/Lvrs Blk CRD	38	872 01 05-20	Bolt 5/16-18 x 2-1/2
5	874 98 10-24	Screw Pan Head #10-24 x 1.50 Blk	39	532 41 62-57	Seal
6	874 98 10-32	Screw Pan Hd	41	532 16 96-83	Bracket Pnt Adj Pvt Bagger CRD
7	873 40 10-00	Nut Wiz Lock Hex Serr/Hd 10-24	46	872 11 05-10	Bolt 5/16-18 x 1-1/4
8	532 18 10-95	Cover Bagger	47	532 19 37-04	Tube Upper Bagger
9	872 14 04-18	Bolt Carriage 1/4-20 x 2.25d x Gr. 5	49	532 19 33-05	Bar Spreader
10	532 18 12-82	Tube Support Bagger CRD	50	873 80 05-00	Nut 5/16-18
11	532 16 57-19	Bracket Support Upper Bag	51	532 19 99-03	Latch Spring Bagger
12	532 18 88-48	Bracket Pivot LH	53	873 51 04-00	Nut 1/4-20 unc
13	874 76 06-12	Bolt Fin Hex 3/8-16 unc x 3/4	54	872 14 04-06	Bolt 1/4-20 x 3/4 Gr. 5
14	874 52 06-36	Bolt Fin Hex 3/8-16 x 2-1/4 Gr. 5	57	872 14 06-22	Bolt Rdhd Sqnk
15	532 12 46-70	Retainer Spring	59	532 43 04-22	Pin Clevis 0.375 x 2.375
16	873 90 06-00	Nut Lock 3/8-16 unc	60	532 00 49-29	Rivet Pan Hd Drilled 1/4
17	872 14 05-06	Bolt Rdhd Sht Sqnk 5/16 -18 unc x 3/4	61	532 12 47-88	Retainer Spring 1"
19	873 90 05-00	Nut Lock Hex Flange 5/16-18	62	532 42 82-39	Actuator Elec
20	532 18 88-47	Bracket Pivot RH	63	532 42 82-38	Bracket Asm. Lower
21	532 40 61-80	Bag Asm CRD	64	532 42 96-64	Bracket Mtg. Upper Left
22	532 42 82-36	Bracket Side Bagger	65	532 42 96-65	Bracket Mtg. Upper Right
24	532 16 57-83	Tube Pivot Bagger CRD	66	532 43 04-24	Plug Bagger
25	532 19 37-05	Tube Front Bagger	69	532 43 56-11	Washer .125
33	532 42 86-83	Plug Mulcher	70	532 43 56-03	Rivet Pop .125 x .750
34	532 16 55-70	Handle Mulcher	71	532 43 83-13	Actuator Support Brkt.
35	532 16 55-72	Pin Mulcher			
36	819 13 20-12	Washer 13/32 x 1-1/4 x 12 Ga.			

**NOTE:** All component dimensions given in U.S. inches  
1 inch = 25.4 mm

