

917.289571
(YTH2348)

ILLUSTRATED PARTS LIST

TRACTOR -- MODEL NUMBER YTH2348 (289571)

DECALS

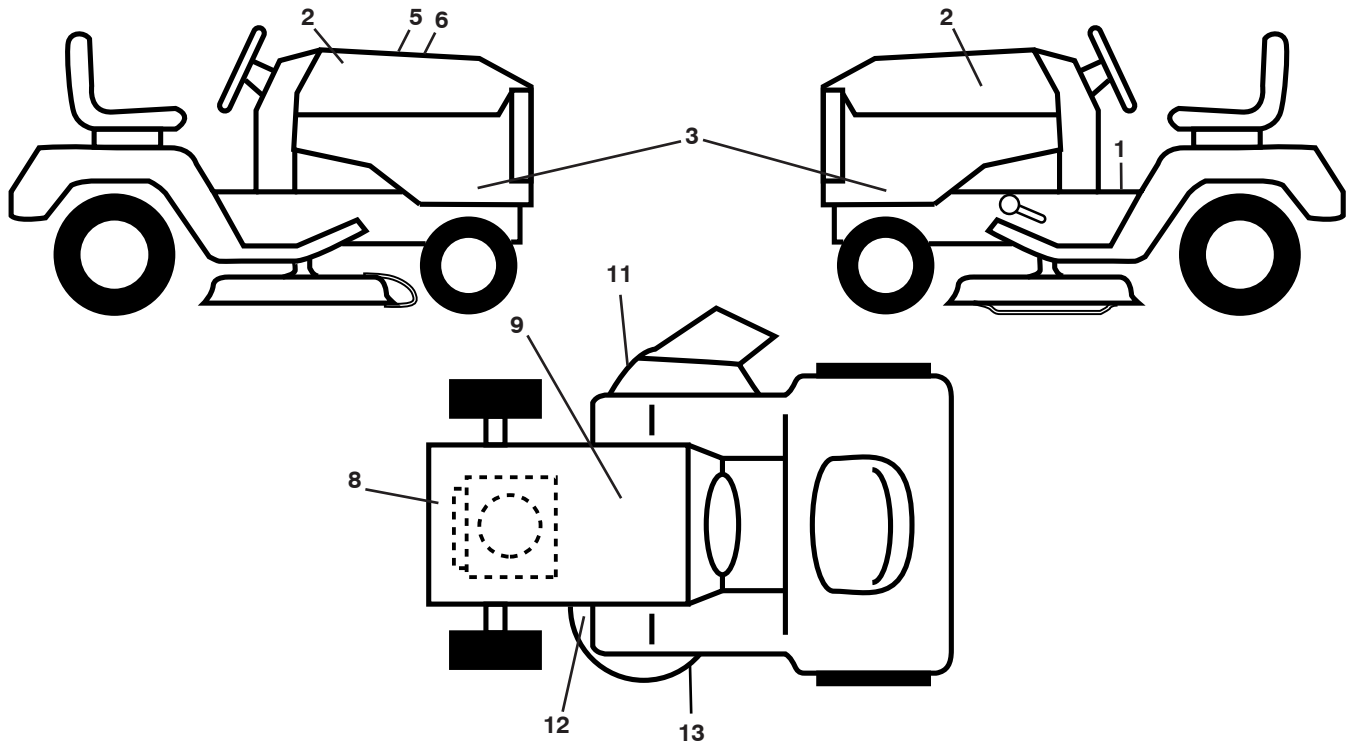

KEY NO.	PART NO.	DESCRIPTION
1	532 41 16-58	Decal, Operators
2	532 42 91-96	Decal, Hood
3	532 41 00-55	Decal, Hood Panel SD
5	532 42 38-29	Decal, Customer Respons.
6	532 43 37-36	Decal, Replacement
8	532 42 95-57	Decal, Eng. HP
9	532 14 50-05	Decal, Battery Dnge/Poi
11	532 17 05-63	Decal, Warning

KEY NO.	PART NO.	DESCRIPTION
12	532 17 84-55	Decal, Mower Caution
13	532 19 87-85	Decal, Mower V-Belt Schematic
--	532 16 69-60	Decal, Bypass
--	532 41 08-05	Pad, Footrest, LH
--	532 41 08-06	Pad, Footrest, RH
--	532 43 63-17	Manual, Owner's (English)
--	532 43 63-19	Manual, Owner's (French)

WHEELS AND TIRES

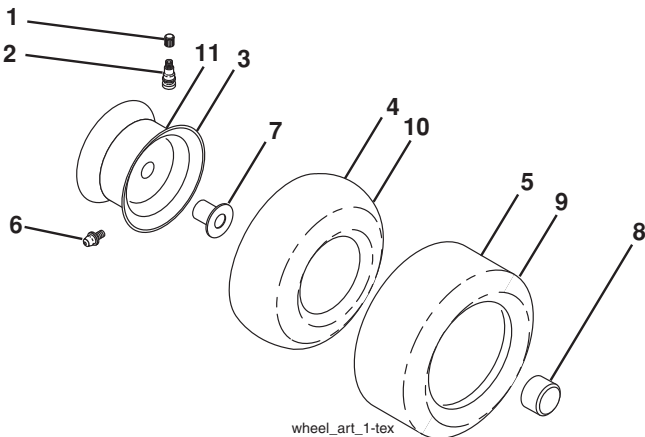

KEY NO.	PART NO.	DESCRIPTION
1	532 05 91-92	Cap Valve Tire
2	532 06 51-39	Stem Valve
3	532 18 18-39	Rim Asm 8" Front Service
4	532 00 81-34	Tube Front (Service Item Only)
5	532 10 62-30	Tire F T 16 x 6.5 Service
6	532 12 49-57	Fitting Grease (Front Wheel Only)
7	532 12 49-59	Bearing Flange (Front Wheel nly)
8	532 17 50-39	Cap Axle Blk 1 50 x 1 00
9	532 13 84-68	Tire R T 18 x 9.5-8 Service
10	532 12 49-26	Tube Rear (Service Item Only)
11	532 13 83-37	Rim Asm 8" Rear Service
--	532 14 43-34	Sealant, Tire (10 oz. Tube)

NOTE: All component dimensions given in U.S. inches
1 inch = 25.4 mm

TRACTOR -- MODEL NUMBER YTH2348 (289571)

SCHEMATIC

SCH12

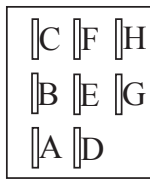
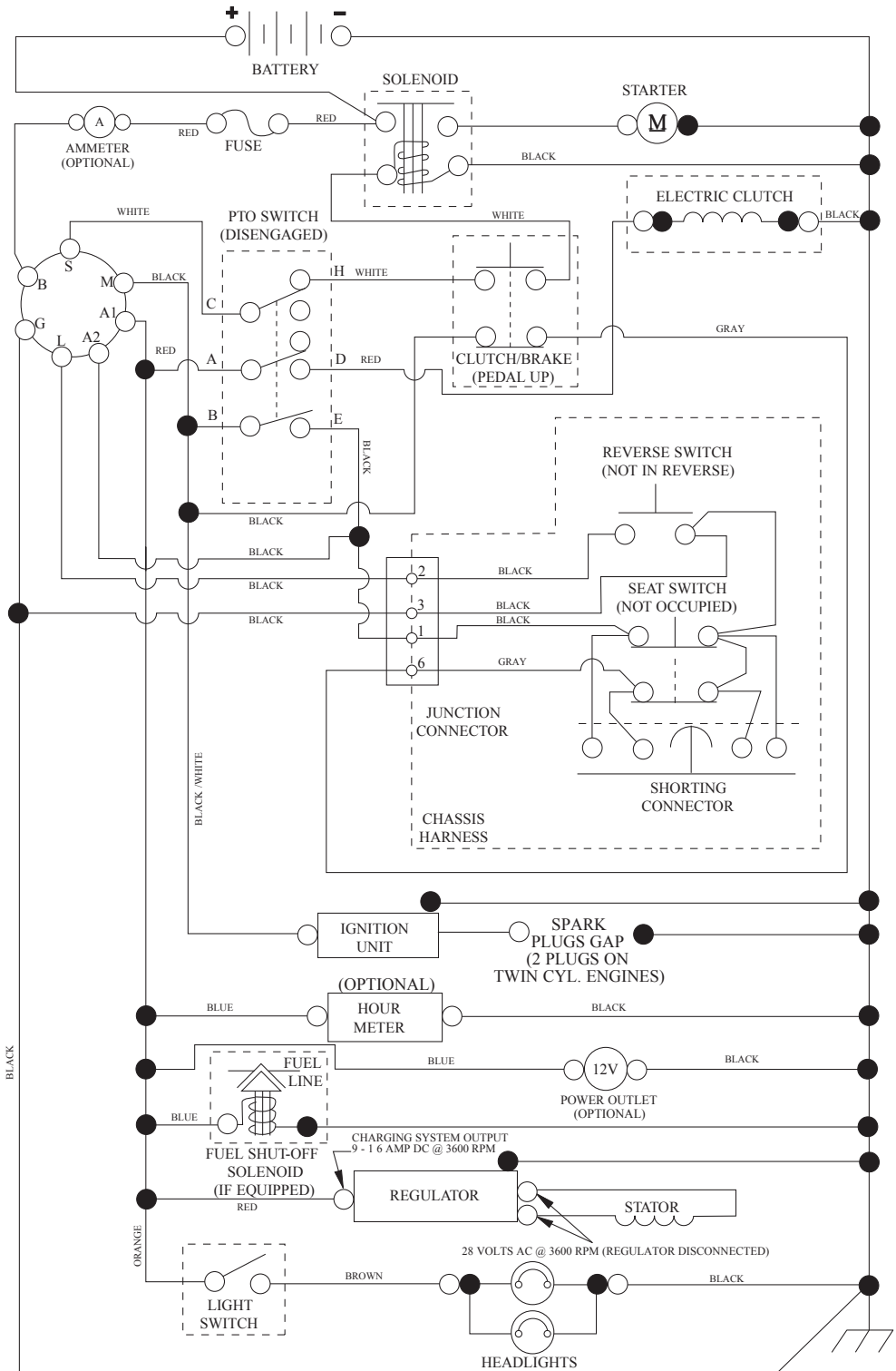

PTO SWITCH
(MATING SIDE)

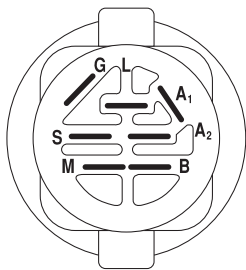

IGNITION SWITCH

POSITION	CIRCUIT	"MAKE"
OFF	M+G+A1	
RUN/OVERRIDE	B+A1	
RUN	B+A1	L+A2
START	B + S + A1	

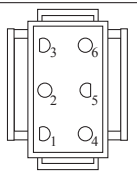

CHASSIS HARNESS
CONNECTOR
(MATING SIDE)

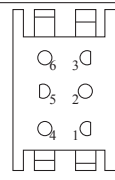

DASH HARNESS
CONNECTOR

WIRING INSULATED CLIPS
NOTE: IF WIRING INSULATED
CLIPS WERE REMOVED FOR
SERVICING OF UNIT, THEY
SHOULD BE RE-INSTALLED TO
PROPERLY SECURE YOUR
WIRING.

●
NON-REMOVABLE
CONNECTIONS

○
REMOVABLE
CONNECTIONS

TRACTOR -- MODEL NUMBER YTH2348 (289571)

ELECTRICAL

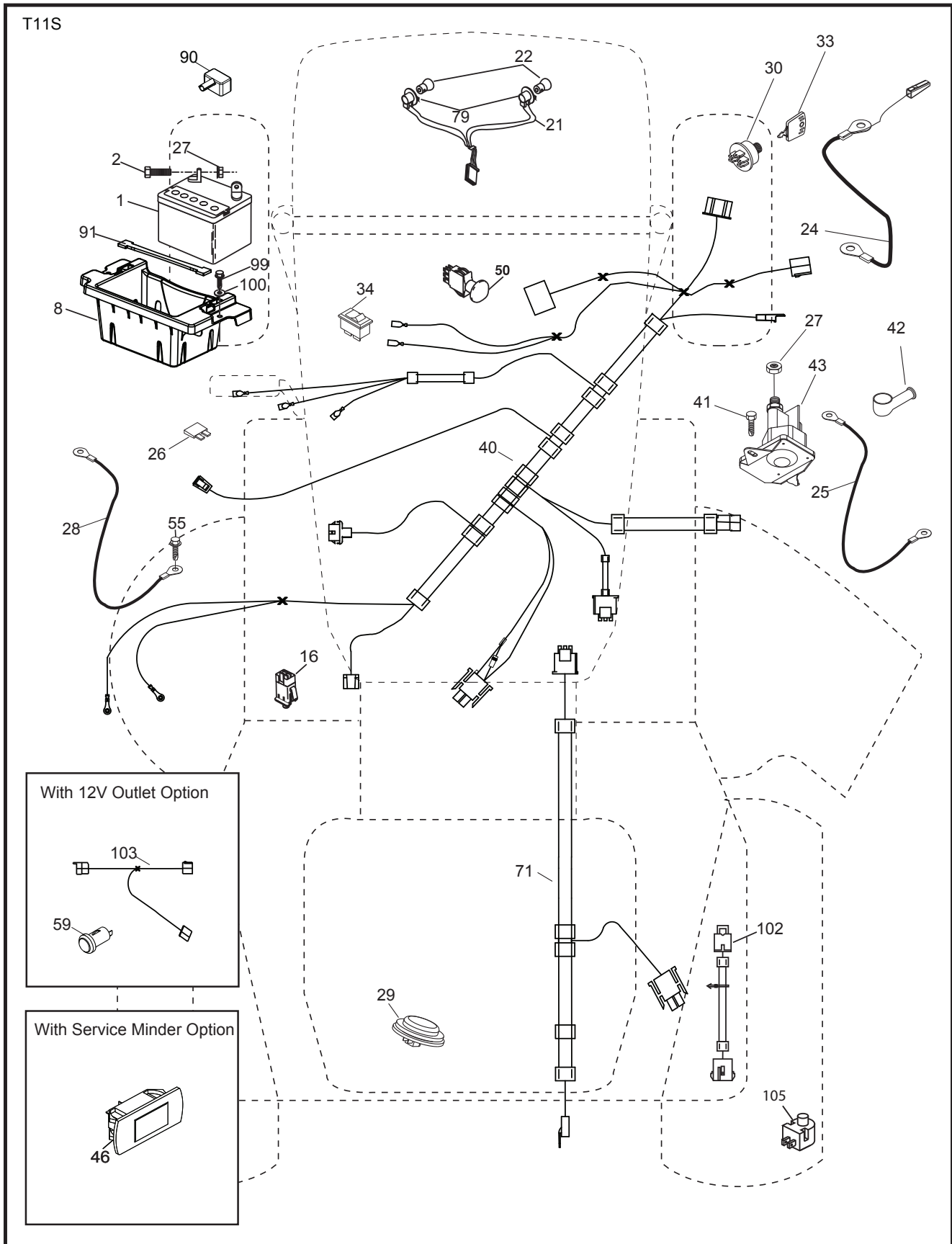

TRACTOR - - MODEL NUMBER YTH2348 (289571)

ELECTRICAL

KEY NO.	PART NO.	DESCRIPTION
1	532 16 34-65	Battery
2	874 76 04-12	Bolt Hex Head 1/4-20 x 3/4
8	532 18 64-91	Box Battery
16	532 17 61-38	Switch Interlock Push-In
21	532 18 37-59	Harness Socket Light w/4152J
22	532 00 41-52	Bulb Light
24	532 40 02-53	Cable Brty
25	532 41 28-95	Cable Starter
26	532 17 51-58	Fuse
27	873 51 04-00	Nut Keps Hex 1/4-20 unc
28	532 14 54-91	Cable, Ground
29	532 40 15-45	Switch, Seat
30	532 19 33-50	Switch, Ign
33	532 41 19-35	Key/Chain
34	532 11 07-12	Switch Light/Reset
40	532 40 11-04	Harness Ign. Dash
41	817 72 04-08	Screw Thd Cut 1/4-20 x 1/2
42	532 13 15-63	Cover, Terminal
43	532 19 25-07	Solenoid
46	532 40 17-63	Gauge Serviceminder Hrmtr
50	532 17 46-51	Switch PTO
55	817 06 05-12	Screw Thdrol 5/16-18 x 3/4 TYTT
71	532 19 42-76	Harness Ign.
79	532 17 52-42	Socket Asm. Bulb Twistlock
90	532 40 07-24	Cover Terminal
91	532 19 02-70	Strap Battery Mount Front
99	817 67 04-12	Screw Hexwsh Thdrol 1/4-20 x 3/4
100	819 09 14-16	Washer 9/32 x 7/8 x 16 Ga.
102	532 40 44-54	Harness Pigtail
105	532 40 75-68	Switch Reverse TT Pedal Control

NOTE: All component dimensions given in U.S. inches
1 inch = 25.4 mm

TRACTOR -- MODEL NUMBER YTH2348 (289571)

CHASSIS

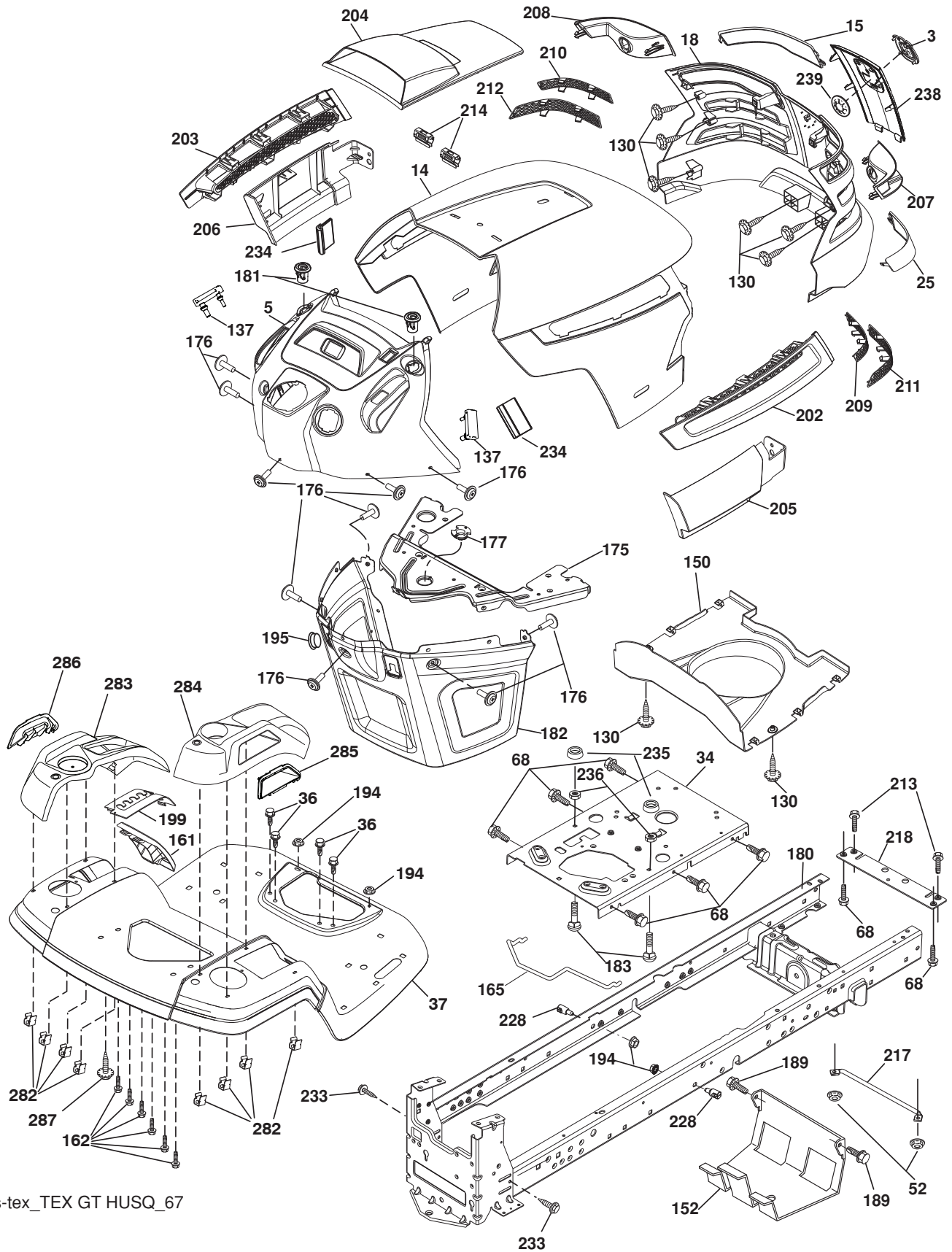

chassis-tex_TEX GT HUSQ_67

TRACTOR - - MODEL NUMBER YTH2348 (289571)

CHASSIS

KEY NO.	PART NO.	DESCRIPTION	KEY NO.	PART NO.	DESCRIPTION
3	532 40 50-12	Logo	204	532 41 66-13	Vent Top Hood
5	532 40 87-00	Dash	205	532 40 17-09	Skirt Hood Side RH
14	532 41 10-46	Hood	206	532 40 17-11	Skirt Hood Side LH
15	532 19 89-07	Lens LH	207	532 19 71-98	Bezel RH
18	532 40 86-07	Grille Asm. (Includes 3, 15, 25, 130, 207, 208, 209-212)	208	532 19 71-99	Bezel LH
25	532 19 89-06	Lens RH	209	532 19 91-30	Insert Hex Top RH
34	532 19 61-25	Plate Engine	210	532 19 91-31	Insert Hex Top LH
36	817 06 05-12	Screw 5/16-18 x 3/4	211	532 19 91-32	Insert Hex Bottom RH
37	532 42 36-94	Fender	212	532 19 91-33	Insert Hex Bottom LH
52	873 68 05-00	Nut Lock 5/16-18	213	874 76 05-12	Bolt 5/16-18 unc x 3/4
68	817 49 05-08	Screw 5/16-18 x 1/2	214	532 19 91-45	Clip Retainer Tinner
130	532 41 63-58	Screw #10 x 0.750 BOS Thread	217	532 40 91-67	Rod Pivot
137	532 40 75-90	Bumper Dash	218	532 19 63-95	X-Piece Hood Stop
150	532 19 85-12	Air Duct	228	532 19 51-61	Stud Fastner
152	532 19 95-35	Shield Browning	233	532 19 65-39	Bolt Shoulder
161	532 40 96-27	Window Fuel	234	532 40 47-42	Bumper Hood
162	532 14 24-32	Screw	235	532 40 61-29	Spacer Fender
165	532 19 68-26	Support Tank Rear	236	873 93 05-00	Nut Lock 5/16-18 unc
175	532 19 63-04	Crossmember	238	532 40 86-06	Trim
176	532 40 07-76	Screw 10-24 x 5/8	282	532 41 41-10	Clip Retainer Console
177	532 19 52-27	Bushing Steering	283	532 41 87-41	Console Deck Lift
178	532 19 97-82	Cargo Net Asm.	284	532 41 78-87	Console Asm. Pedal Control
180	532 19 54-57	Chassis	285	532 41 63-15	Console Insert RH
181	532 40 30-25	Bushing Mtg. Fender Crgo	286	532 41 63-17	Console Insert LH
182	532 40 68-59	Dash Lower	287	817 60 04-06	Screw Hex Washhead 1/4-20 x 3/8
183	874 52 05-20	Bolt 5/16-18 unc x 1-1/4	298	532 11 05-52	Nut, Push
189	817 00 05-12	Screw 5/16-18 x 3/4	--	532 43 18-83	Kit Bumper (Not Shown)
194	873 90 05-00	Nut Lock Hex Flange 5/16-18			
195	532 40 41-37	Plug Hole Dash Lower			
199	532 41 34-85	Plate Deck Lift			
202	532 40 30-48	Vent Side Hood RH			
203	532 40 30-76	Vent Side Hood LH			

NOTE: All component dimensions given in U.S. inches
1 inch = 25.4 mm

TRACTOR -- MODEL NUMBER YTH2348 (289571)

DRIVE

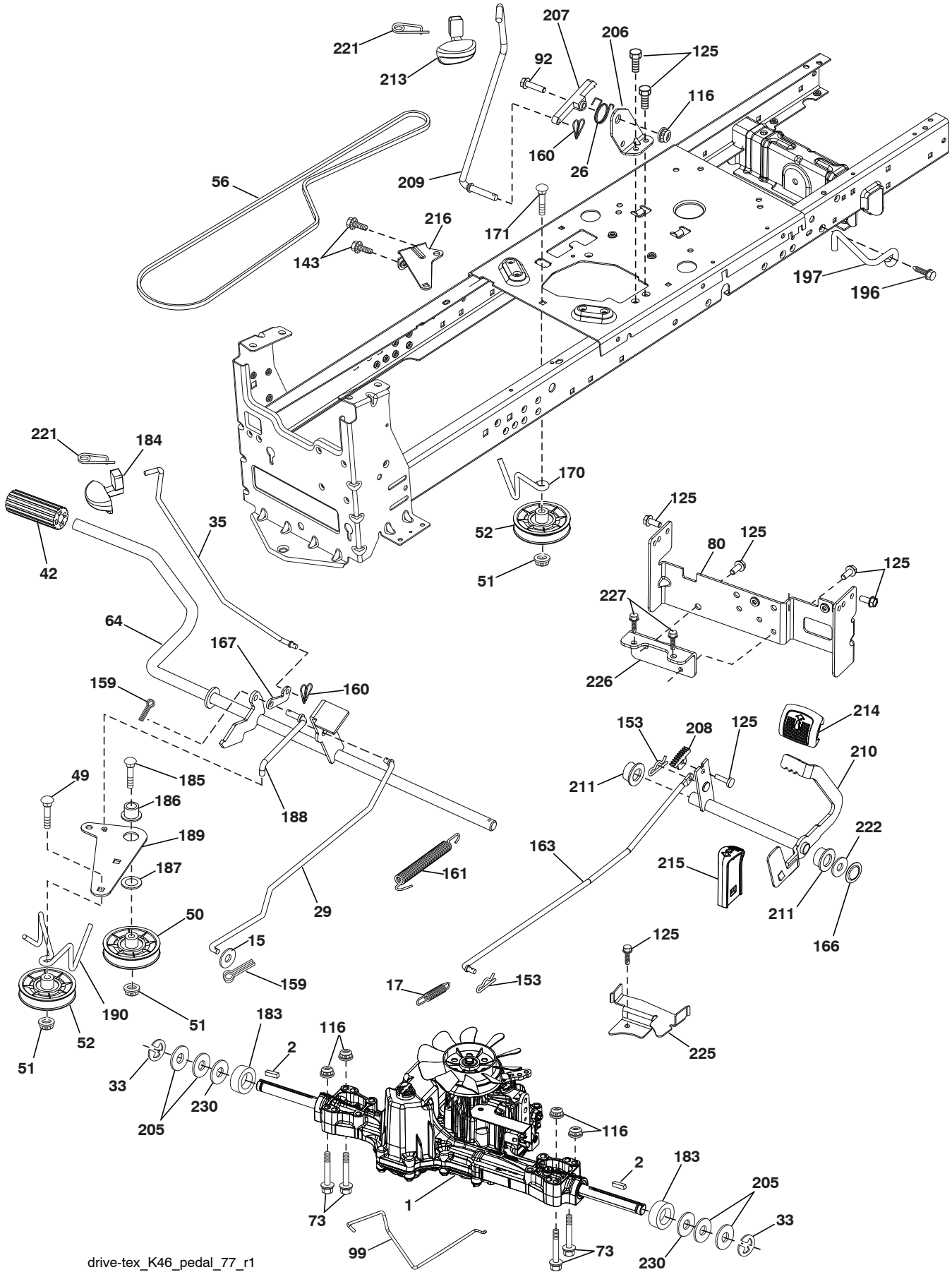

drive-tex_K46_pedal_77_r1

TRACTOR - - MODEL NUMBER YTH2348 (289571)

DRIVE

KEY NO.	PART NO.	DESCRIPTION	KEY NO.	PART NO.	DESCRIPTION
1	-----	Transaxle, TUFFTORQ K46 BT (See Transaxle breakdown)	171	872 11 06-16	Bolt RDHD SQNK 3/8-16 unc x 2
2	532 12 35-83	Key	183	532 13 70-57	Spacer Split
15	819 13 13-16	Washer 13/32 x 13/16 x 16 Ga.	184	532 40 31-18	Handle Parking Brake
17	532 41 36-78	Spring, Brake	185	872 11 06-22	Bolt Rdhd 3/8-16 unc x 2-3/4 Gr. 5
26	532 19 96-79	Spring Return Cruise	186	532 19 43-21	Spacer Retainer
29	532 40 38-06	Rod, Brake	187	819 13 32-10	Washer
33	812 00 00-01	Ring E	188	532 19 43-23	Link Clutch Ground Drive
35	532 19 95-91	Rod, Brake, Park	189	532 19 43-17	Bellcrank Ground Drive
42	532 12 48-72	Cover, Foot Pedal	190	532 19 43-18	Keeper Bellcrank Ground Drive
49	872 11 06-14	Bolt	196	817 00 06-16	Screw 3/8-16 x 1
50	532 19 43-27	Pulley Idler Flat	197	532 19 58-04	Bracket Clutch Anti-Rotation
51	873 90 06-00	Lock Nut 3/8-16	205	532 12 17-48	Washer
52	532 19 43-26	Idler V-Groove 910" Offset	206	532 19 78-67	Bracket Mount Latch Cruise
56	532 13 09-69	V-Belt, Drive	207	532 19 78-68	Latch Control Cruise
64	532 19 78-65	Shaft Asm. Pedal Brake Control	208	532 19 78-69	Gear Sector Control Cruise
73	874 49 05-44	Bolt Hex Flghd 5/16-18 Gr. 5	209	532 19 95-92	Rod Control Cruise
80	532 41 00-24	Bracket Strap Torque	210	532 40 09-80	Rocker Asm. Pedal Control
92	874 76 05-20	Bolt Fin Hex 5/16-18 unc x 1.25	211	532 12 01-83	Bearing Nylon
99	532 41 57-42	Rod Spring Bypass	213	532 40 31-19	Knob Control Cruise
116	873 90 05-00	Nut Lock Hex Flange 5/16-18	214	532 42 12-63	Pedal Forward
125	817 00 05-12	Screw 5/16-18 x 3/4	215	532 40 17-23	Pedal Reverse
143	817 49 05-08	Screw 5/16-18 x 1/2	216	532 19 61-31	Bracket Pulley Idler
153	532 12 47-88	Retainer Spring	221	532 40 31-87	Retainer Spring Clip Handle
159	876 02 04-12	Pin Cotter 1/8 x 3/4	222	879 21 20-10	Washer 21/32 x 1-1/4 10 Ga.
160	532 16 94-84	Retainer Clip	225	532 40 33-19	Keeper Belt Trans.
161	532 10 57-09	Spring, Return, Clutch	226	532 40 15-64	Bracket Mount Torque
163	532 40 10-34	Rod Pedal Control	227	817 49 05-12	Screw Thdrol 5/16-18 x 3/4
166	532 42 91-64	Nut Push	230	532 18 89-67	Washer Hardened
167	532 40 52-57	Latch Brake Parking			
170	532 19 43-22	Keeper Belt Centerspan			

NOTE: All component dimensions given in U.S. inches
1 inch = 25.4 mm

TRACTOR -- MODEL NUMBER YTH2348 (289571)

ENGINE

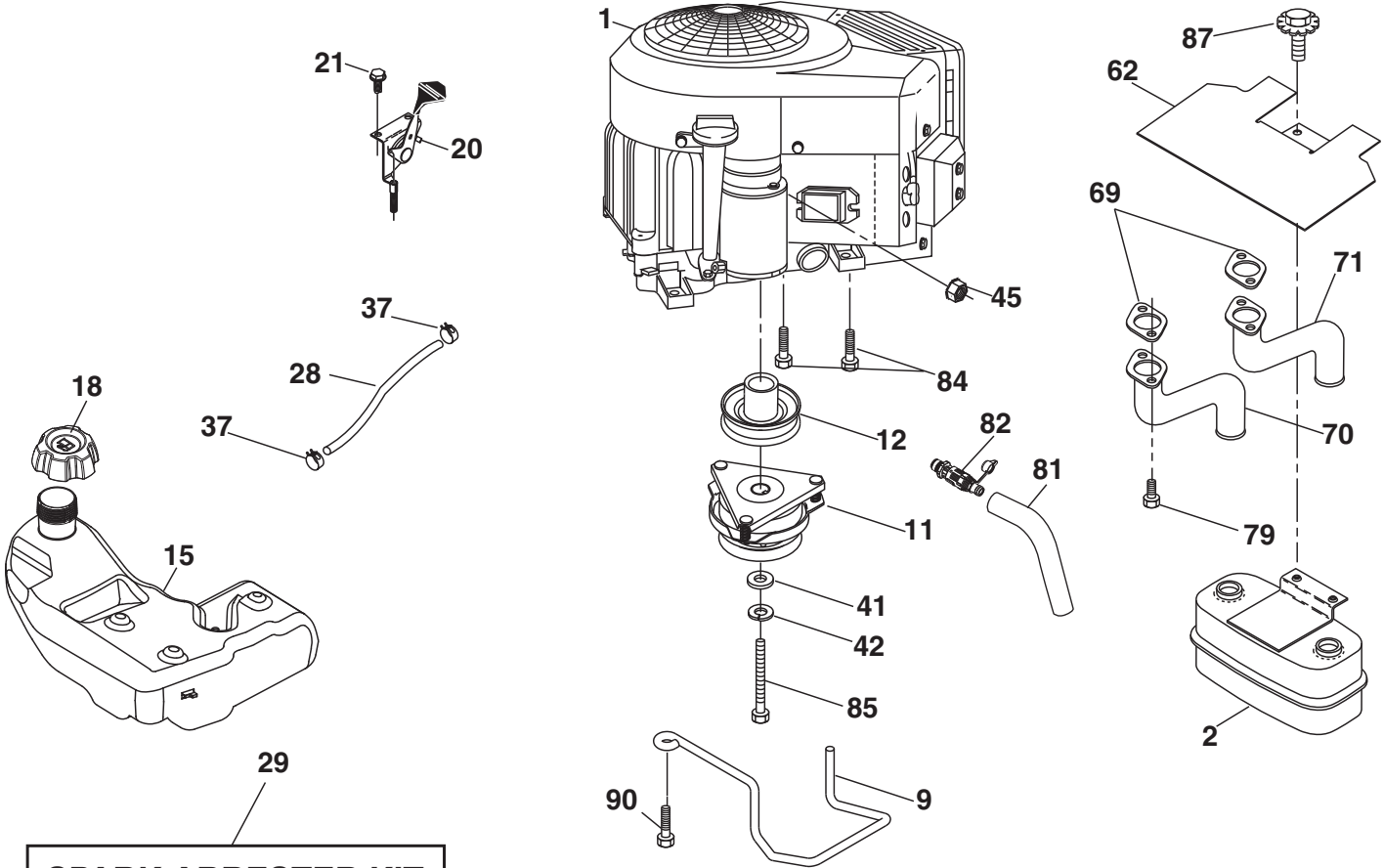

SPARK ARRESTER KIT

engine-tex_bs-2cyl_64

TRACTOR - - MODEL NUMBER YTH2348 (289571)

ENGINE

KEY NO.	PART NO.	DESCRIPTION
1	-----	Engine B&S Model No. 445577 1187-B1
2	532 14 97-23	Muffler
9	532 19 43-20	Keeper Belt Engine
11	532 40 00-08	Clutch Ogura
12	532 40 50-97	Pulley Engine
15	532 40 00-21	Tank Fuel
18	532 43 02-17	Cap
20	532 42 35-02	Control Throttle
21	532 41 63-58	Screw #10 x 0.750 BOS Thread
28	532 40 11-35	Fuel Line
29	532 13 71-80	Spark Arrester Kit
37	532 12 34-87	Clamp Hose
41	532 12 61-97	Washer 1-1/2 OD x 15/32 ID x .250
42	810 04 07-00	Washer Lock 7/16
45	873 51 04-00	Nut Keps Hex 1/4-20 unc
62	532 43 40-17	Shield Heat Muffler
69	532 16 53-91	Gasket
70	532 15 99-55	Exhaust Tube LH
71	532 16 05-89	Exhaust Tube RH
79	532 18 39-06	Screw Socket Head 5/16-18 x 1
81	532 14 84-56	Tube Drain Oil Easy
82	532 42 82-87	Plug Drain Oil
84	817 06 06-20	Screw 3/8-16 x 1-1/4
85	532 17 39-37	Bolt 7/16-20 x 4
87	532 17 18-77	Bolt 5/16-18 x 3/4
90	817 00 06-16	Screw 3/8-16 x 1

NOTE: All component dimensions given in U.S. inches
1 inch = 25.4 mm

For engine service and replacement parts, call the toll free number for your engine manufacturer listed below:

Briggs & Stratton 1-800-233-3723

Engine Power Rating Information

The gross power rating for individual gas engine models is labeled in accordance with SAE (Society of Automotive Engineers) code J1940 (Small Engine Power & Torque Rating Procedure), and rating performance has been obtained and corrected in accordance with SAE J1995 (Revision 2002-05). Torque values are derived at 3060 RPM; horsepower values are derived at 3600 RPM. Actual gross engine power will be lower and is affected by, among other things, ambient operating conditions and engine-to-engine variability. Given both the wide array of products on which engines are placed and the variety of environmental issues applicable to operating the equipment, the gas engine will not develop the rated gross power when used in a given piece of power equipment (actual "on-site" or net power). This difference is due to a variety of factors including, but not limited to, accessories (air cleaner, exhaust, charging, cooling, carburetor, fuel pump, etc.), application limitations, ambient operating conditions (temperature, humidity, altitude), and engine-to-engine variability. Due to manufacturing and capacity limitations, Briggs & Stratton may substitute an engine of higher rated power for this Series engine.

TRACTOR - - MODEL NUMBER YTH2348 (289571)

STEERING ASSEMBLY

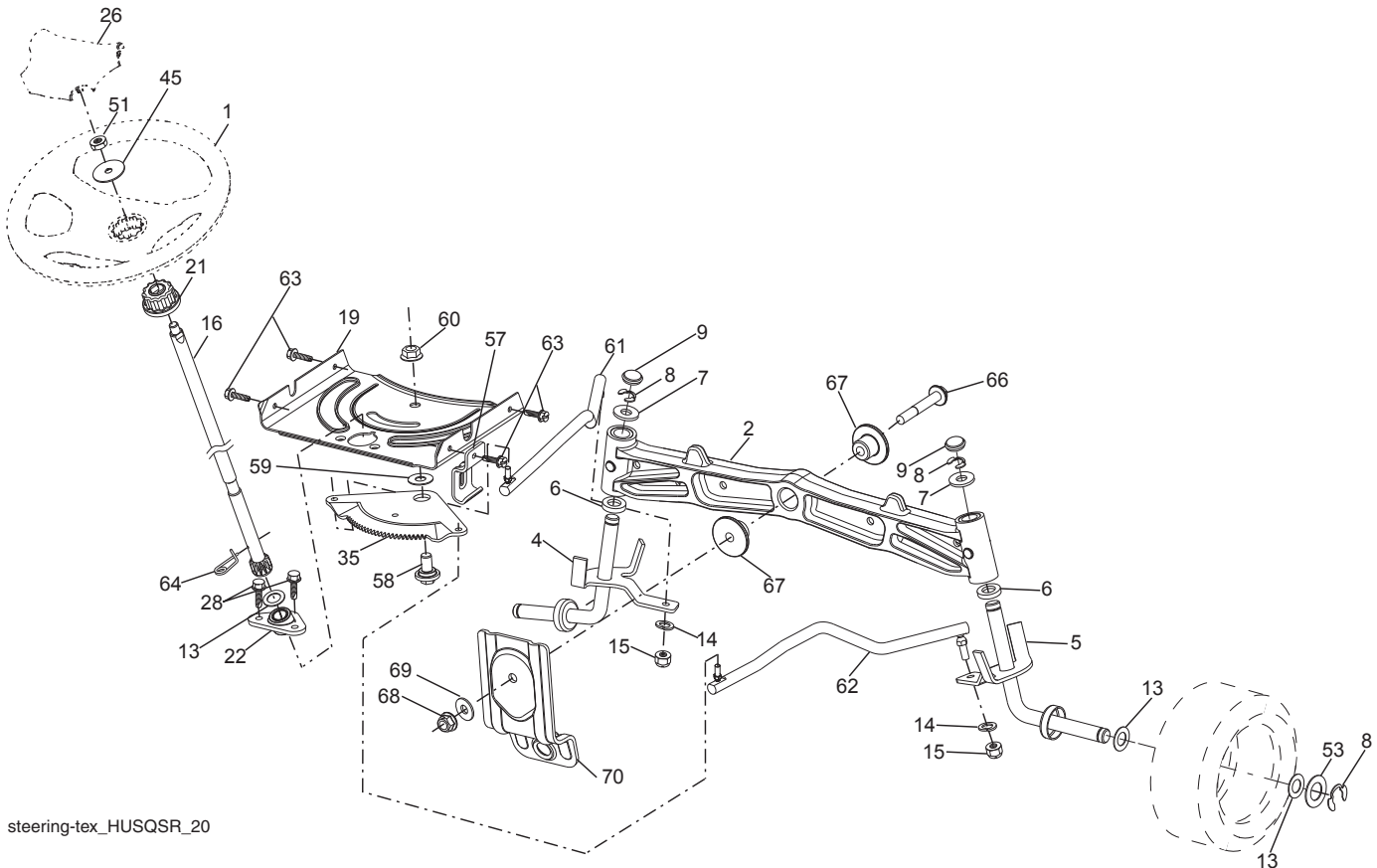

steering-tex_HUSQSR_20

KEY NO.	PART NO.	DESCRIPTION
1	532 41 64-80	Wheel, Steering
2	532 19 59-68	Axle Asm., Front
4	532 40 30-89	Spindle Asm., LH
5	532 40 30-90	Spindle Asm., RH
6	532 12 49-31	Bearing, Race Thrust Harden
7	532 12 17-48	Washer 25/32 x 1-5/8 x 16 Ga.
8	812 00 00-29	Ring, Klip #T5304-75
9	532 12 12-32	Cap, Spindle
13	532 12 17-49	Washer 25/32 x 1-1/4 x 16 Ga.
14	810 04 06-00	Washer, Lock Hvy Hlcl Spr 3/8
15	873 54 06-00	Nut, Crown Lock 3/8-24 unf
16	532 40 82-19	Shaft Steering
19	532 19 47-29	Plate Steering
21	532 18 67-37	Adapter, Wheel Steering
22	532 42 05-37	Support Strg. Lower
26	532 41 59-87	Insert, Wheel Steering
28	817 00 06-12	Screw 3/8-16 x 3/4
35	532 19 47-32	Gear, Sector Plate
45	819 18 38-12	Washer 9/16 ID x 2-3/8 OD 12 Ga.

KEY NO.	PART NO.	DESCRIPTION
51	873 94 08-00	Nut Hex Jam Toplock 1/2-20 unf
53	532 18 89-67	Washer Hardened .793x1.637x.060
57	532 19 72-46	Bracket Upstop
58	532 19 47-47	Bolt Shoulder Sector Pivot CFM
59	532 19 47-48	Washer Thrust Sector Steering
60	873 97 10-00	Nut Flange Lock 5/8-11
61	532 19 47-40	Draglink, LH
62	532 19 47-41	Draglink, RH
63	817 00 05-12	Screw 5/16-18 x 3/4
64	532 19 98-49	Retainer Clip Spring Steering
66	871 02 07-48	Bolt Hex Fghd 7/16-14 x 3 Serr
67	532 19 47-37	Bushing PM Front Axle
68	873 90 07-00	Nut Lock Flange 7/16-14 Gr. 5
69	532 19 91-62	Washer 1.5 x .505 x .118
70	532 19 61-97	Bracket Deck Susp. Front

NOTE: All component dimensions given in U.S. inches
1 inch = 25.4 mm

TRACTOR -- MODEL NUMBER YTH2348 (289571)

SEAT ASSEMBLY

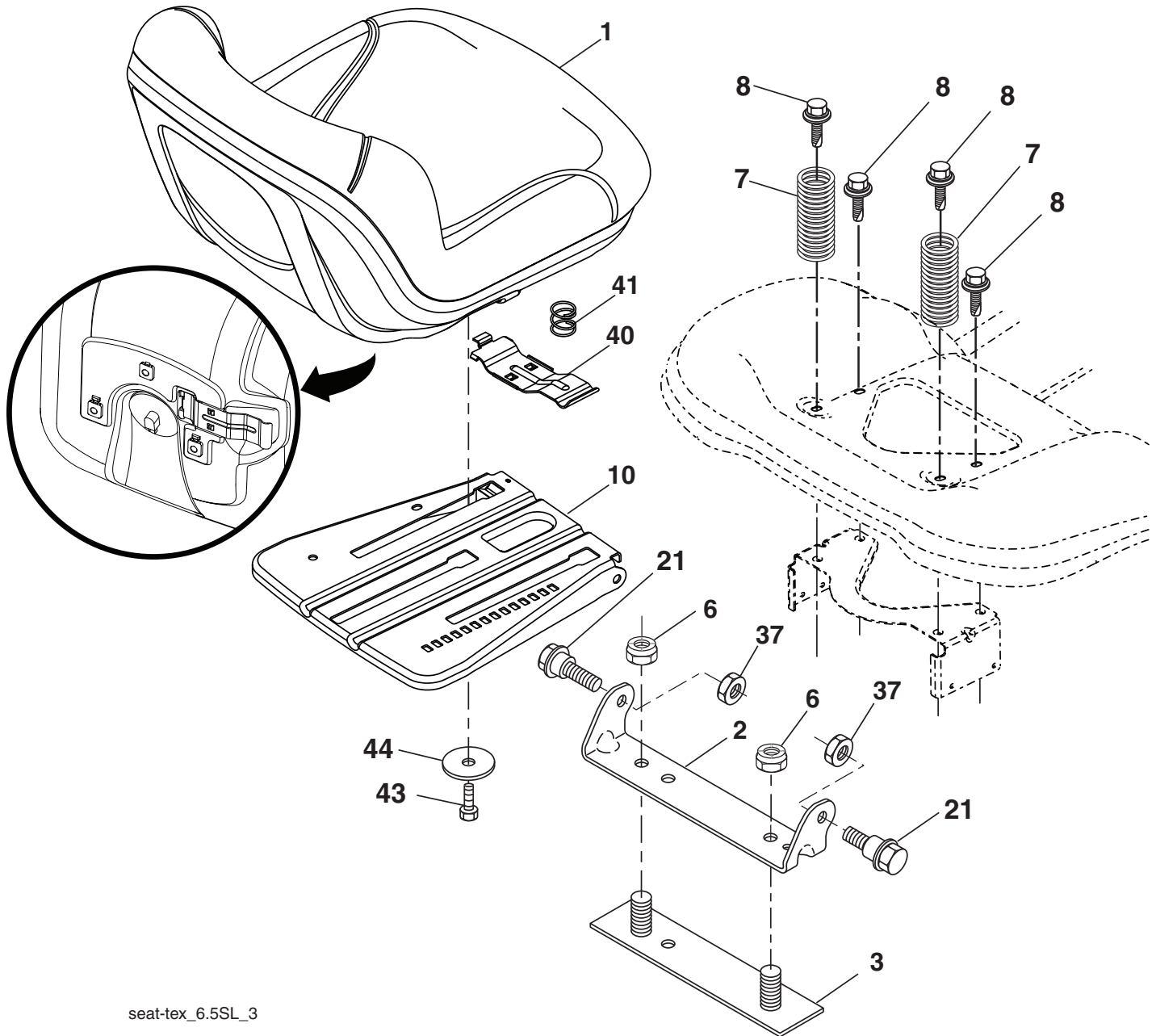

seat-tex_6.5SL_3

KEY NO.	PART NO.	DESCRIPTION
1	532 42 40-68	Seat
2	532 18 01-66	Bracket Pivot Fender
3	532 14 06-75	Strap, Asm Fender
4	873 80 06-00	Nut, Lock w/Ins. 3/8-16 unc
5	532 12 41-81	Spring, Seat Cprsn
6	532 17 18-77	Bolt 5/16-18 unc x 3/4 w/Sems
7	532 19 69-77	Pan, Seat
8	532 17 18-52	Bolt, Shoulder 5/16-18
9	873 80 05-00	Nut, Lock 5/16-18 unc

KEY NO.	PART NO.	DESCRIPTION
10	532 19 76-61	Handle Slide Seat
11	532 19 82-00	Spring Latch Seat
12	874 76 06-12	Bolt Fin Hex 3/8-16 unc x 3/4
13	819 13 38-12	Washer 13/32 x 2-3/8 x 12 Ga.

NOTE: All component dimensions given in U.S. inches
1 inch = 25.4 mm

TRACTOR -- MODEL NUMBER YTH2348 (289571)

MOWER DECK

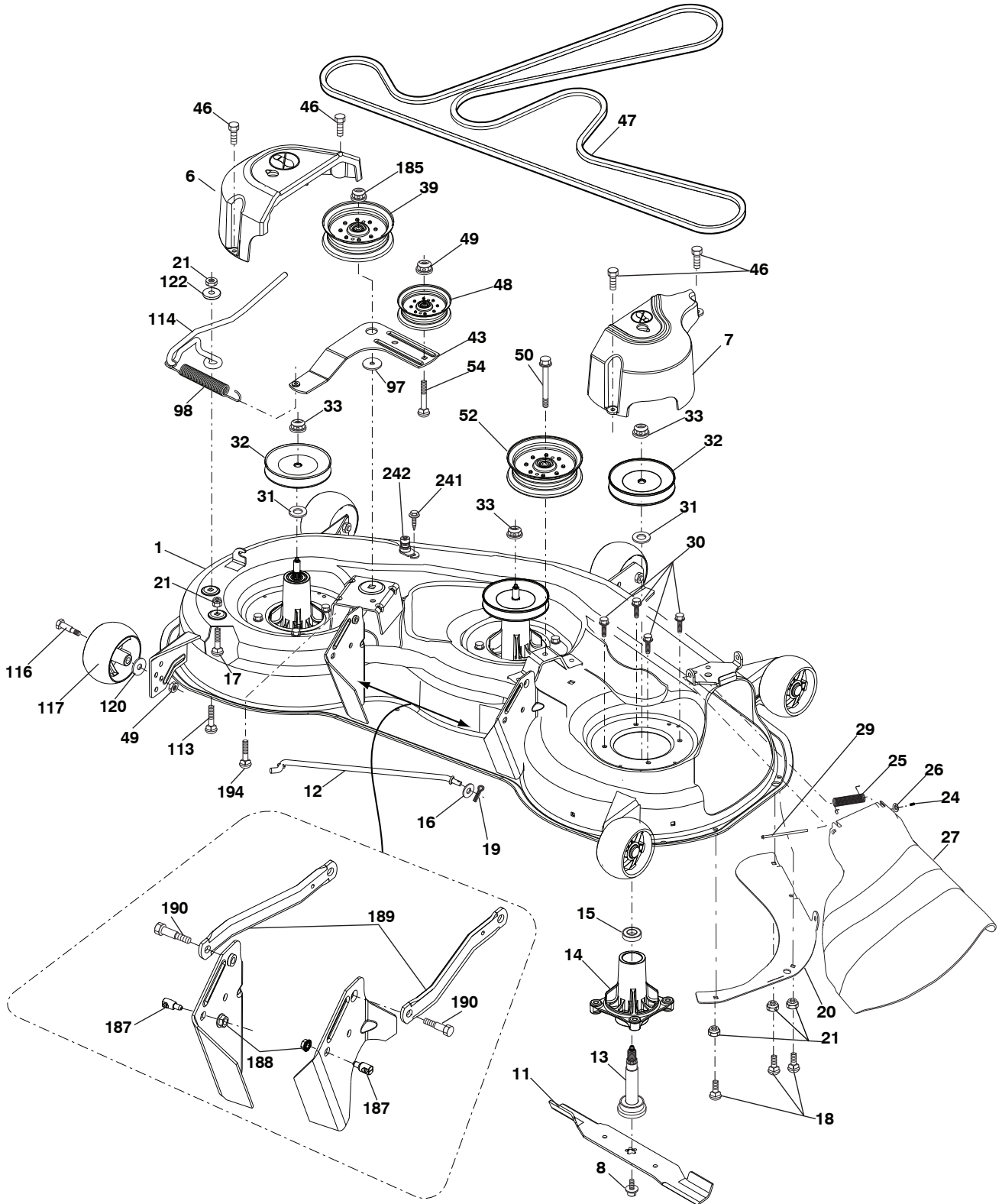

48_Deck_tex_26_r1

TRACTOR - - MODEL NUMBER YTH2348 (289571)

MOWER DECK

KEY NO.	PART NO.	DESCRIPTION	KEY NO.	PART NO.	DESCRIPTION
1	532 40 35-82	Deck Weldment Mower	49	873 90 06-00	Nut, Lock Flg. 3/8-16 unc
6	532 19 72-48	Cover Mandrel LH	50	817 49 06-36	Screw 3/8-16 x 1-1/4 unc
7	532 19 91-02	Cover Mandrel RH	52	532 19 31-97	Pulley Idler
8	532 19 30-03	Bolt/Washer Asm. 7/16-20 unf	54	872 11 06-12	Bolt Carriage 3/8-16 x 1-1/2 Gr. 5
11	532 18 00-54	Blade High Lift	97	532 17 85-15	Washer Hardened
--	532 17 39-21	Blade Mulching	98	532 19 61-05	Spring Drive
12	532 40 48-51	Rod Anti-Sway	113	872 11 05-08	Bolt Rdhd Sqnk 5/16-18 x 3/4
13	532 18 72-91	Shaft Asm. w/Lower Bearing	114	532 19 74-51	Rod Tension Relief
14	532 18 72-81	Housing, Mandrel	116	532 19 34-06	Bolt, Shoulder
15	532 11 04-85	Bearing, Ball, Mandrel	117	532 17 48-73	Gauge Wheel
16	819 13 13-12	Washer 13/23 x 13/16 x 1 2 Ga.	120	819 13 20-12	Washer 13/32 x 1-1/4 x 12 Ga.
17	872 11 05-05	Bolt Carr. 5/16-18 x 5/8	122	532 18 75-57	Bushing Tension Relief
18	872 14 05-05	Bolt RdHd 5/16-18 unc x 5/8	185	873 90 07-00	Nut Lock Flange 7/16-14 Gr. 5
19	532 19 42-08	Pin Cotter 5/16 Bowtie Lock	187	532 19 51-61	Stud Fastener w/"D" Anti-Rotation
20	532 17 43-78	Baffle Vortex	188	873 90 05-00	Nut Lock Hex Flange
21	873 68 05-00	Nut, Crownlock 5/16-18 unc	189	532 19 51-85	Arm Susp. Mower Rear
24	532 10 53-04	Cap Sleeve	190	532 19 65-39	Bolt Shoulder
25	532 17 81-02	Spring, Torsion	194	872 14 07-16	Bolt Carr Sqnk 3/8-16 x 2-1/4
26	532 11 04-52	Nut, Push	241	532 15 29-27	Screw TT 10-32 .5 .3/8
27	532 18 17-07	Deflector Shield	242	532 41 55-98	Port Washout
29	532 13 14-91	Rod, Hinge	--	532 41 64-05	Coupling Quick Connect
30	532 17 39-84	Screw, Thdroll Washer Head	--	532 18 72-92	Mandrel Assembly (Includes hous- ing, shaft assembly, and bearing only - pulley/nut/washer and blade bolt/washers not included)
31	532 18 76-90	Washer, Spacer Mower	--	532 43 18-25	Replacement Mower, Complete
32	532 15 35-32	Pulley, Mandrel			
33	532 40 02-34	Nut, Flg. Top Lock			
39	532 19 73-80	Pulley, Idler, 4.50 HUB			
43	532 19 60-65	Arm, Idler			
46	532 13 77-29	Screw, Thdroll. 1/4-20 x 5/8			
47	532 19 72-42	Belt Drive Deck			
48	532 19 73-79	Pulley Idler 4.50 Raw			

NOTE: All component dimensions given in U.S. inches
1 inch = 25.4 mm

TRACTOR -- MODEL NUMBER YTH2348 (289571)

MOWER LIFT

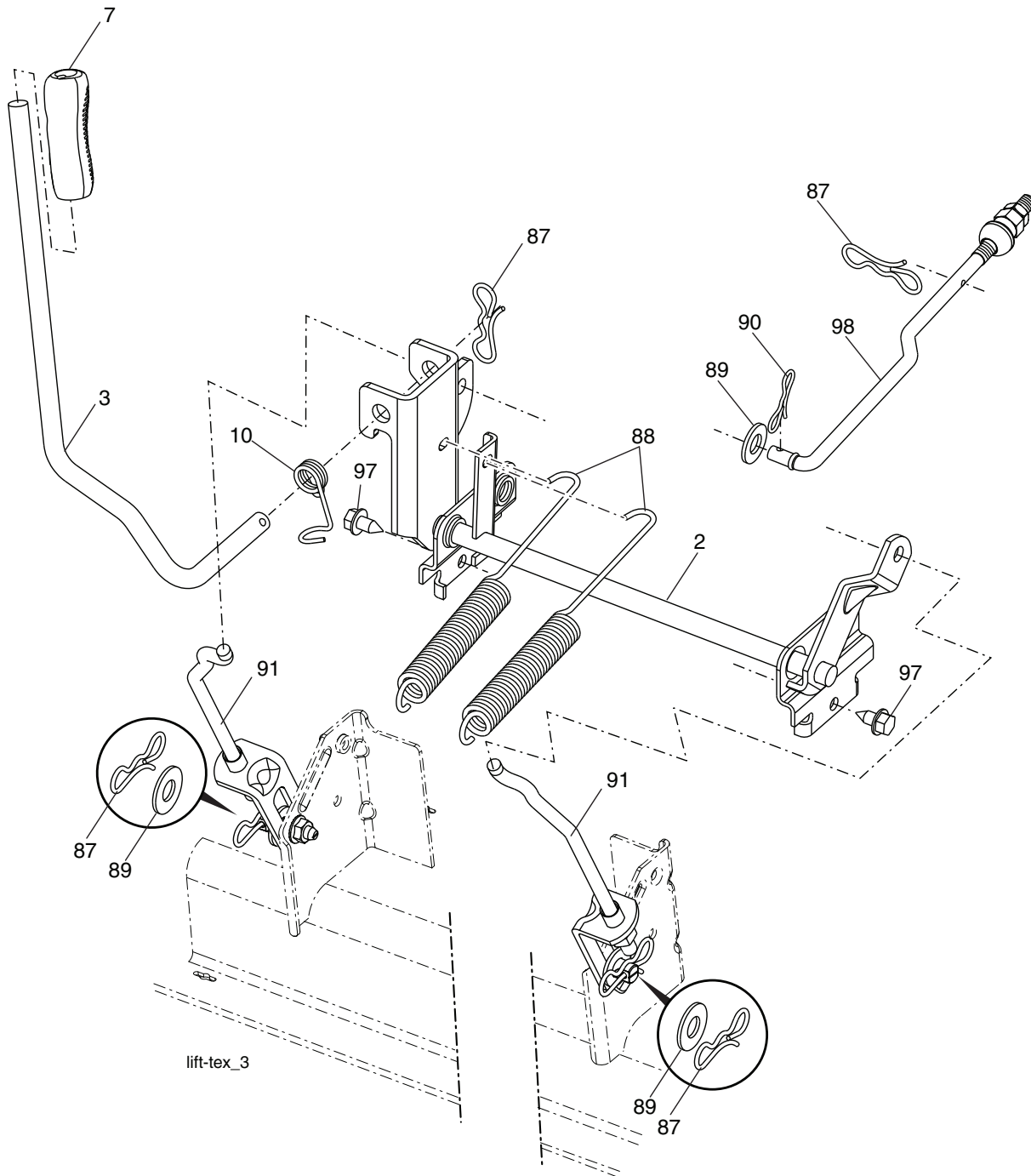

KEY NO.	PART NO.	DESCRIPTION
2	532 42 20-27	Shaft Asm., Lift
3	532 19 52-31	Lever Asm., Lift RH
7	532 41 15-55	Grip, Lever
10	532 19 63-14	Spring Torsion
87	532 19 42-09	Pin Cotter 7/16 Bow Tie Lock
88	532 41 07-10	Spring Lift Assist
89	819 19 19-12	Washer Clear Zinc

KEY NO.	PART NO.	DESCRIPTION
90	532 19 42-08	Pin Cotter 5/16 Bow Tie Lock
91	532 19 51-81	Link Lift Susp Mower Rear
97	817 00 06-12	Screw HEXWSH THDR 3/8-16x3/4
98	532 19 52-64	Link Lift Susp. Front Mower

NOTE: All component dimensions given in U.S. inches
1 inch = 25.4 mm

TRACTOR - - MODEL NUMBER YTH2348 (289571)

BRIGGS ENGINE - MODEL NUMBER 445577, TYPE NUMBER 1187-B1

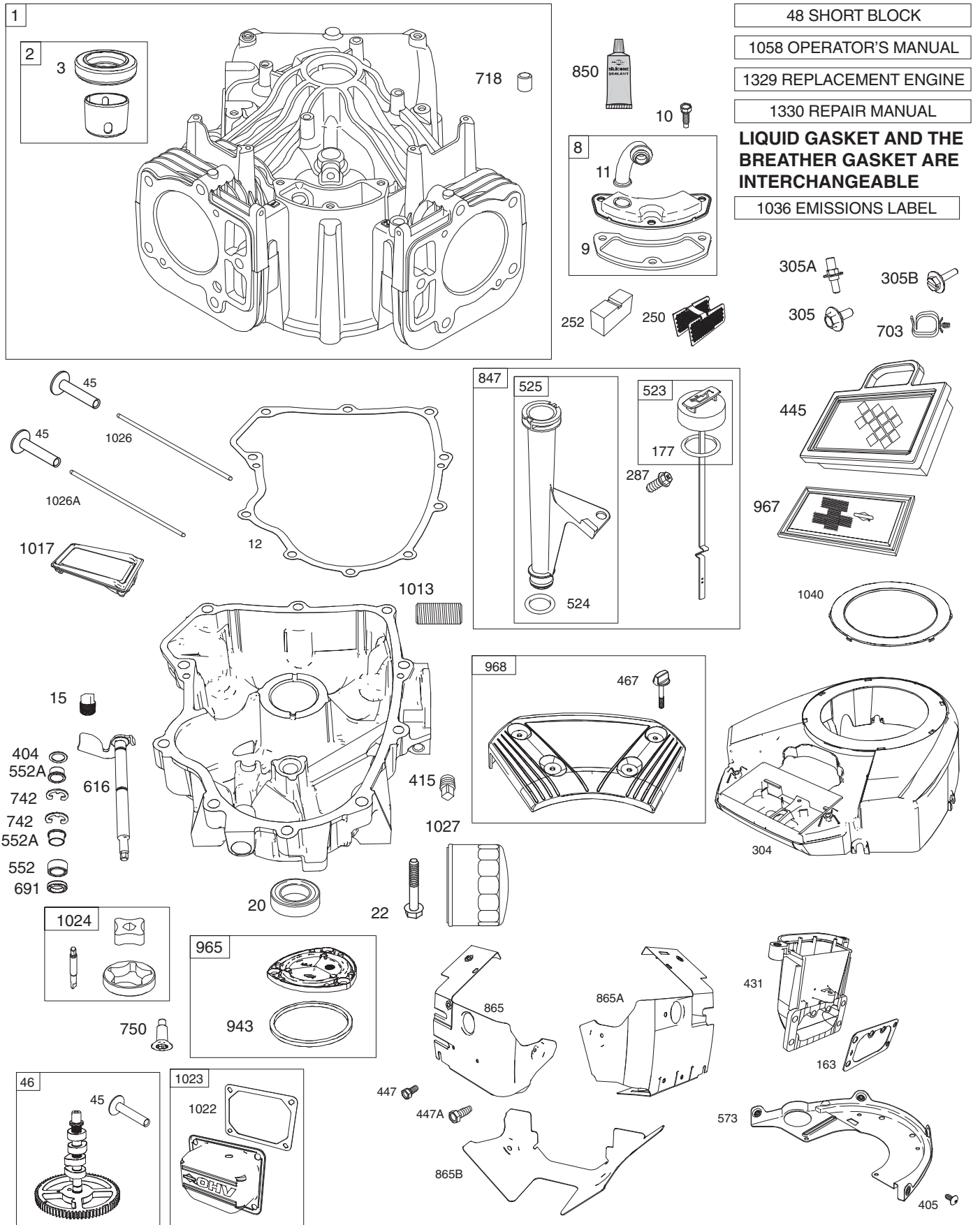

TRACTOR - - MODEL NUMBER YTH2348 (289571)

BRIGGS ENGINE - MODEL NUMBER 445577, TYPE NUMBER 1187-B1

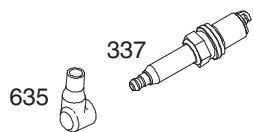
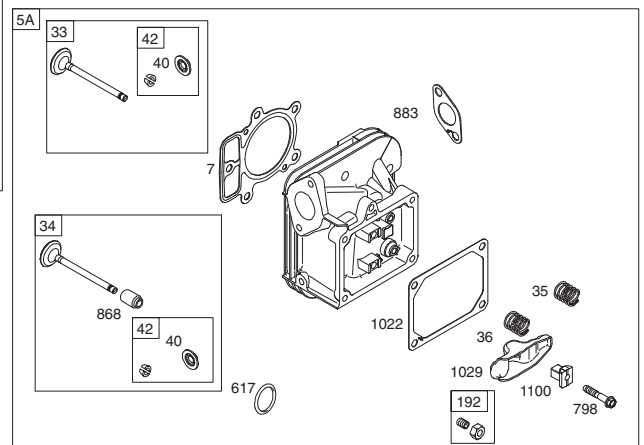
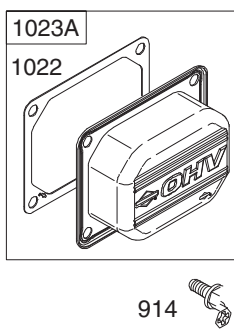
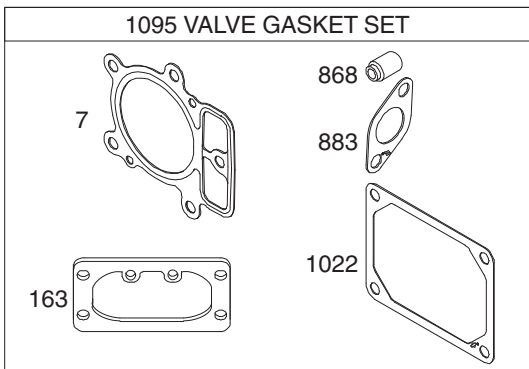
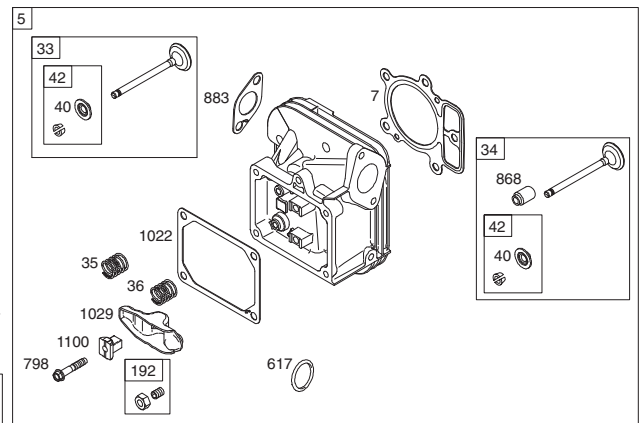
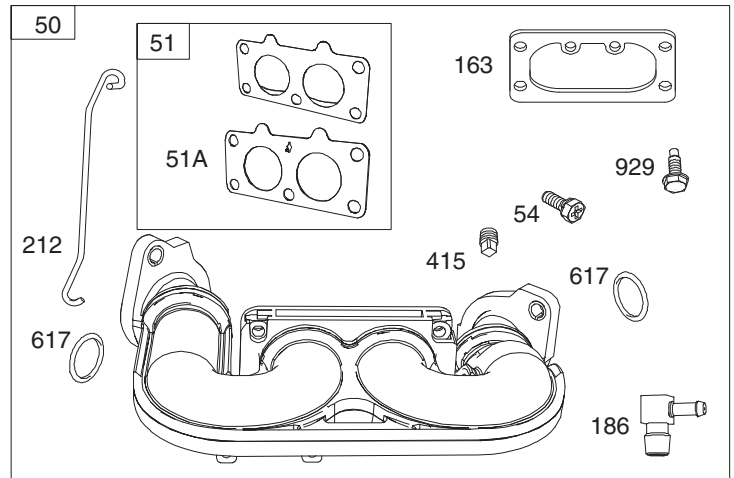
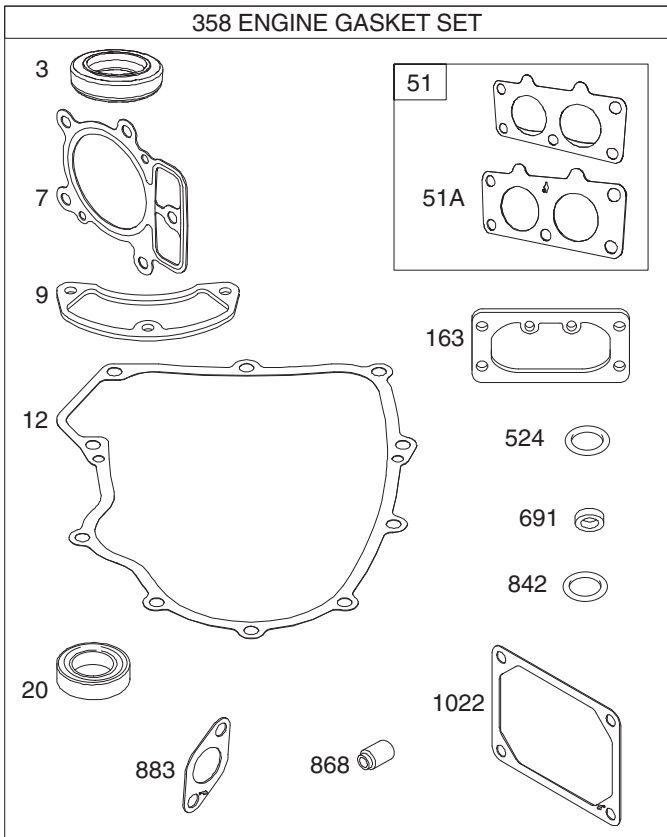
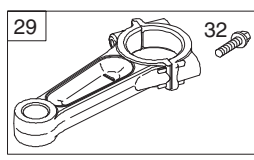
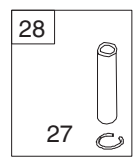
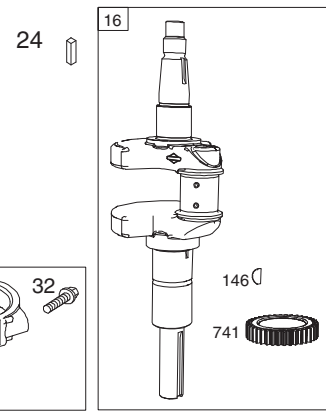
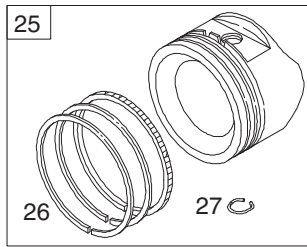
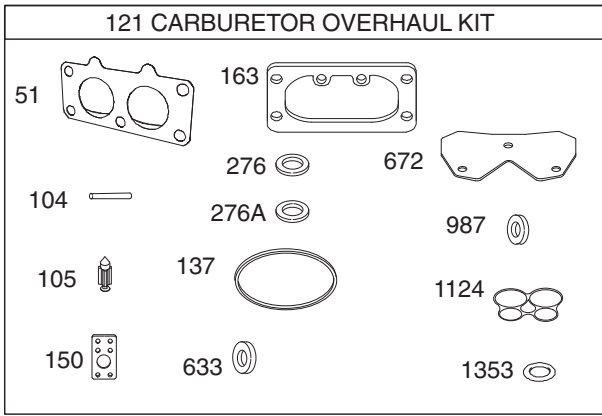

TRACTOR - - MODEL NUMBER YTH2348 (289571)

BRIGGS ENGINE - MODEL NUMBER 445577, TYPE NUMBER 1187-B1

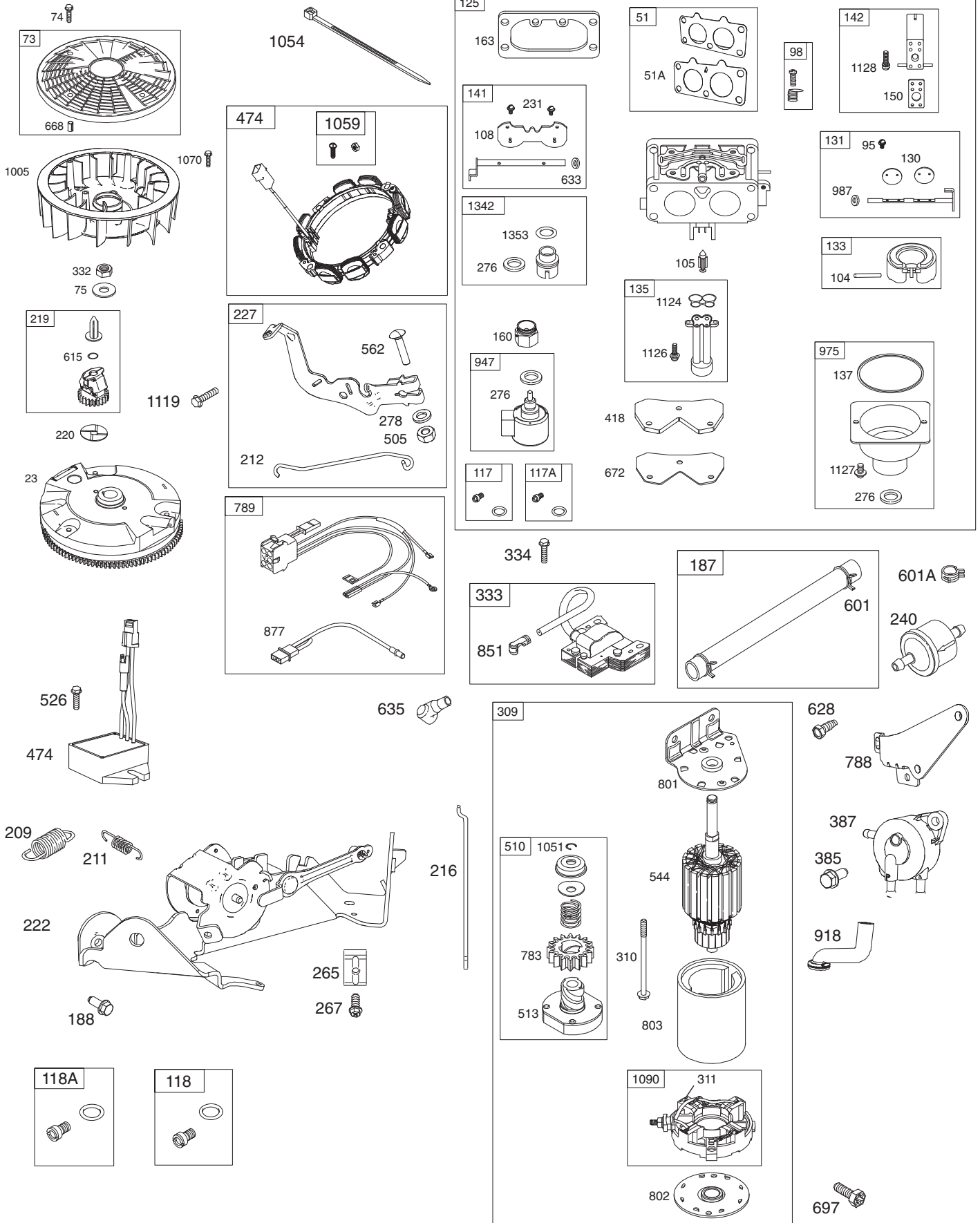

TRACTOR - - MODEL NUMBER YTH2348 (289571)

BRIGGS ENGINE - MODEL NUMBER 445577, TYPE NUMBER 1187-B1

KEY NO.	PART NO.	DESCRIPTION	KEY NO.	PART NO.	DESCRIPTION
1	793564	Cylinder Assembly	130	690993	Valve-Throttle
2	499585	Bushing/Seal Kit (MagnetoSide)	131	499805	Kit-Throttle Shaft
3	• 391086s	Seal-Oil (Magneto Side)	133	699724	Float-Carburetor
4	796230	Sump-Engine	135	699729	Tube-Fuel Transfer
5	796231	Head-Cylinder (Cylinder #1)	137 +	690994	Gasket-Float Bowl
5A	796232	Head-Cylinder (Cylinder #2)	141	796228	Kit-Choke Shaft
7	•∅ 693997	Gasket-Cylinder Head	142	699726	Nozzle-Carburetor
8	792185	Breather Assembly	146	690979	Key-Timing
9	• 690937	Gasket-Breather (Liquid Gasket and The Breather Gasket Are Interchangeable)	150	690995	Gasket-Nozzle
			160	699727	Retainer-Solenoid (Brass)
			163	691001	Gasket-Air Cleaner
10	697551	Screw (Breather Assembly)	177	691031	Seal-O Ring (Dipstick)
11	792184	Tube-Breather	186	796532	Hose-Connector (Oil Drain Hose)
12	• 697227	Gasket-Crankcase	187	791766	Line-Fuel (Cut to RequiredLength)
13	793988	Screw (Cylinder Head)	188	697551	Screw (Control Bracket)
15	690946	Plug-Oil Drain	192	690083	Adjuster-Rocker Arm
16	796540	Crankshaft	197	697820	Screw (Back Plate)
20	• 795389	Seal-Oil (PTO Side)	209	796224	Spring-Governor (Yellow/Black)
22	694966	Screw (Crankcase Cover/Sump)	211	796225	Spring-Governed Idle (Orange)
23	691053	Flywheel	212	695238	Link-Throttle
24	222698s	Key-Flywheel	216	796229	Link-Choke
25	792023	Piston Assembly (Standard)	217	695409	Spring-Choke Return
	792072	Piston Assembly (020" Oversize)	219	793338	Gear-Governor
26	793561	Ring Set (Standard)	220	690412	Washer (Governor Gear)
	792073	Ring Set (.020" Oversize)	221	841026	Cup-Governor
27	690975	Lock-Piston Pin	222	796226	Bracket-Control
28	696581	Pin-Piston	227	796223	Lever-Governor Control
29	699699	Rod-Connecting	231	690718	Screw (Choke Valve)
32	690976	Screw (Connecting Rod)	240	691035	Filter-Fuel
33	697576	Valve-Exhaust	250	690957	Retainer-Breather
34	792200	Valve-Intake	252	690956	Collector-Oil
35	694865	Spring-Valve (Intake)	265	691024	Clamp-Casing
36	694865	Spring-Valve (Exhaust)	267	792629	Screw (Casing Clamp)
40	690964	Retainer-Valve	276	794271	Washer-Sealing (Aluminum)
42	499586	Keeper-Valve	278	792651	Washer (Governor Control Lever)
45	690977	Tappet-Valve	287	691108	Screw (Dipstick Tube)
46	790562	Camshaft	304	796597	Housing-Blower
48	698172	Short Block	305	691005	Screw (Blower Housing)
50	695241	Manifold-Intake	305A	698336	Screw (Blower Housing)
51	•∅+ 795123	Gasket-Intake	305B	790690	Screw (Blower Housing) (Blower Housing to Intake Elbow)
51A	•∅+ 690950	Gasket-Intake			
53	690951	Stud (Carburetor)	309	497595	Motor-Starter
54	699816	Screw (Intake Manifold)	310	690323	Screw (Starter Motor)
73	494439	Screen-Rotating	332	691059	Nut (Flywheel)
74	698425	Screw (Rotating Screen)	333	691060	Armature-Magneto
75	691056	Washer (Flywheel)	334	691061	Screw (Magneto Armature)
95	690718	Screw (Throttle Valve)	337	491055s	Plug-Spark
98	699721	Kit-Idle Speed	358	694012	Gasket Set-Engine
104 +	694918	Pin-Float Hinge	385	697551	Screw (Fuel Pump)
105 +	698537	Valve-Float Needle	387	808656	Pump-Fuel
108	699723	Valve-Choke	404	690442	Washer (Governor Crank)
117	791501	Jet-Main (Standard) (Left)	415	794903	Plug (Oil Pressure Switch Hole)
117A	791502	Jet-Main (Standard) (Right)	415A	690283	Plug (Intake Manifold)
118	695415	Jet-Main (High Altitude) (Left)	418	795912	Plate-Carburetor
118A	843099	Jet-Main (High Altitude) (Right)	431	790816	Elbow-Intake
121	792455	Kit-Carburetor Overhaul	445	499486s	Filter-Air Cleaner Cartridge
125	796259	Carburetor	447	691003	Screw (Air Guide Cover) (Long)

TRACTOR - - MODEL NUMBER YTH2348 (289571)

BRIGGS ENGINE - MODEL NUMBER 445577, TYPE NUMBER 1187-B1

KEY NO.	PART NO.	DESCRIPTION	KEY NO.	PART NO.	DESCRIPTION
447A	697551	Screw (Air Guide Cover) (Short)	877	790544	Wire/Connector-Alternator
462	691261	Washer (Starter Cable)	883 •	690970	Gasket-Exhaust
467	691008	Knob-Air Cleaner	914	691127	Screw (Rocker Cover)
474	696458	Alternator	918	793147	Hose-Vacuum
501	691185	Regulator	943 •	796222	Seal-O Ring (Oil Pump Cover)
505	691029	Nut (Governor Control Lever)	947	699728	Solenoid-Fuel
510	696541	Drive-Starter	965	796221	Cover-Oil Pump
512	796530	Hose-Oil Drain	967	273638s	Filter-Pre Cleaner
513	692024	Clutch-Drive	968	791242	Cover-Air Cleaner
523	691036	Dipstick	975	499810	Bowl-Fuel
524 •	691032	Seal-Dipstick Tube	987 +	691000	Seal-Throttle Shaft
525 •	691037	Tube-Dipstick	1005	791236	Fan-Flywheel
526	697551	Screw (Regulator)	1013	690954	Nipple-Oil Filter
544		Armature-Starter (Service by 497595 Starter Motor Only, Reference 309)	1017	796214	Screen-Oil Pump
			1022 Ø•	690971	Gasket-Rocker Cover (Liquid Gasket and Rocker Cover Gasket are Interchangeable)
552	690552	Bushing-Governor Crank	1023	793146	Cover-Rocker (Cylinder #1)
552A	690553	Bushing-Governor Crank	1023A	499600	Cover-Rocker (Cylinder #2)
562	690311	Screw (Governor Control Lever)	1024	796220	Pump-Oil
573	790444	Plate-Back	1026	690981	Rod-Push (Steel)
601	791850	Hose-Clamp (Green)	1026A	690982	Rod-Push (Aluminum)
601A	691038	Hose-Clamp (Black)	1027	492932s	Filter-Oil
615	698290	Retainer-Governor Shaft	1029	690972	Arm-Rocker
616	691045	Crank-Governor	1036		Label-Emissions (Available from a Briggs & Stratton Authorized Dealer)
617 •+	697891	Seal-O Ring (Intake Manifold) (Red)			Ring-Retaining
628	697551	Screw (Fuel Pump Bracket)	1051	691265	Tie-Cable
633	699813	Seal-Choke/Throttle Shaft (Choke Shaft)	1054	280275	Operator's Manual
635	66538s	Boot-Spark Plug	1058	276245	Kit-Screw/Washer
654	690958	Nut (Carburetor)	1059	698516	Screw (Flywheel Fan)
668	691215	Spacer (Rotating Screen)	1070	791680	Retainer-Brush
672	690234	Gasket-Carburetor Plate	1090	691293	Gasket Set-Valve
691 •	790574	Seal-Governor Shaft	1095	694013	Pivot-Rocker Arm
697	690372	Screw (Drive Cap)	1000	791959	Screw (Alternator)
703	691010	Clip	1119	691183	Seal-O Ring (Fuel Transfer Tube)
718	690959	Pin-Locating	1124	690988	Screw (Fuel Transfer Tube)
742	690328	Retainer-E Ring	1126	690991	Screw (Float Bowl)
750	796208	Screw (Oil Pump Cover)	1127	690992	Screw (Carburetor Nozzle)
783	695708	Gear-Pinion	1128	690990	
788	793145	Bracket-Fuel Pump	1329	44Q777-	
789	698330	Harness-Wiring		0037	Replacement Engine
798	697890	Screw (Rocker Arm)	1330	273521	Repair Manual
801	691283	Cap-Drive	1342	699731	Extension-Fuel Transfer Tube
802	691286	Cap-End	1353	699725	Seal-O Ring (Fuel Transfer Tube Extension)
803		Housing-Starter (Service by 497595 Starter Motor Only, Reference 309)			
847	499602	Dipstick/Tube Assembly			
850	100106	Sealant-Liquid (Used to Seal Breather Assembly and Rocker Cover)	•		Included in Engine Gasket Set, Key. No. 358
851	493880s	Terminal-Spark Plug	Ø		Included in Valve Gasket Set, Key No. 1095
865	691012	Cover-Air Guide (Cylinder #1)	+		Included in Carburetor Overhaul Kit, Key, No. 121
865A	796541	Cover-Air Guide (Cylinder #2)			
865B	691015	Cover-Air Guide (Cylinder #3)			
868 Ø•	690968	Seal-Valve			

NOTE: All component dimensions given in U.S. inches, 1 inch = 25.4 mm

**TRACTOR - - MODEL NUMBER YTH2348 (289571)
TUFFTORQ TRANSAXLE MODEL NUMBER K46BT**

KEY NO.	PART NO.	DESCRIPTION
7	532 41 43-95	Vent Valve 15
8	532 41 43-96	Magnet
9	532 41 43-97	Magnet Holder
10	532 41 59-23	Pump Shaft/Bearing Kit
13	532 41 43-98	Bypass Lever
15	532 41 43-99	Sealing Cap 30
16	532 41 44-00	Snap Ring C 35
19	532 41 44-01	O-Ring 1a P10a
20	532 41 44-02	Seal Tc 153507
33	532 41 44-03	Pump Shaft (Standard)
34	532 41 44-04	E-Ring 15
35	532 41 44-05	Bearing 6202c3
53	532 41 44-31	Control Lever F
55	532 41 59-24	Washer 12
58	532 41 59-25	Roll Pin 6 * 40
59	532 41 59-26	O-Ring 1a P14
60	532 41 59-27	Nut 12
72	532 41 44-07	Seal 19 * 32 * 8
76	532 41 44-08	Brake Lever
78	532 41 44-09	Brake Return Spring
80	532 41 44-10	Spring Pin 5 * 32
81	532 41 44-11	O-Ring 1a P12
82	532 41 44-12	Spring Pin 4 * 16
83	532 41 44-13	Spine Collar
84	532 41 44-14	Pulley L
85	532 41 44-15	Fan, Black
86	532 41 44-16	Wave Washer
87	532 41 44-17	Snap Ring
90	532 41 44-18	Spring Pin 3.0a * 20
91	532 41 44-19	Oil Seal 16 * 22 *.03
95	532 41 48-50	Spring Pin 3.0a*16
96	532 41 44-20	Roll Pin 3.5 * 40
115	532 41 59-28	Switch 6440-11 Delta
116	532 41 59-29	Switch Bracket
117	532 41 59-30	Tapping Screw 8 * 20

NOTE: All component dimensions given in U.S. inches.
1 inch = 25.4 mm

SERVICE NOTES

SUGGESTED GUIDE FOR SIGHTING SLOPES FOR SAFE OPERATION

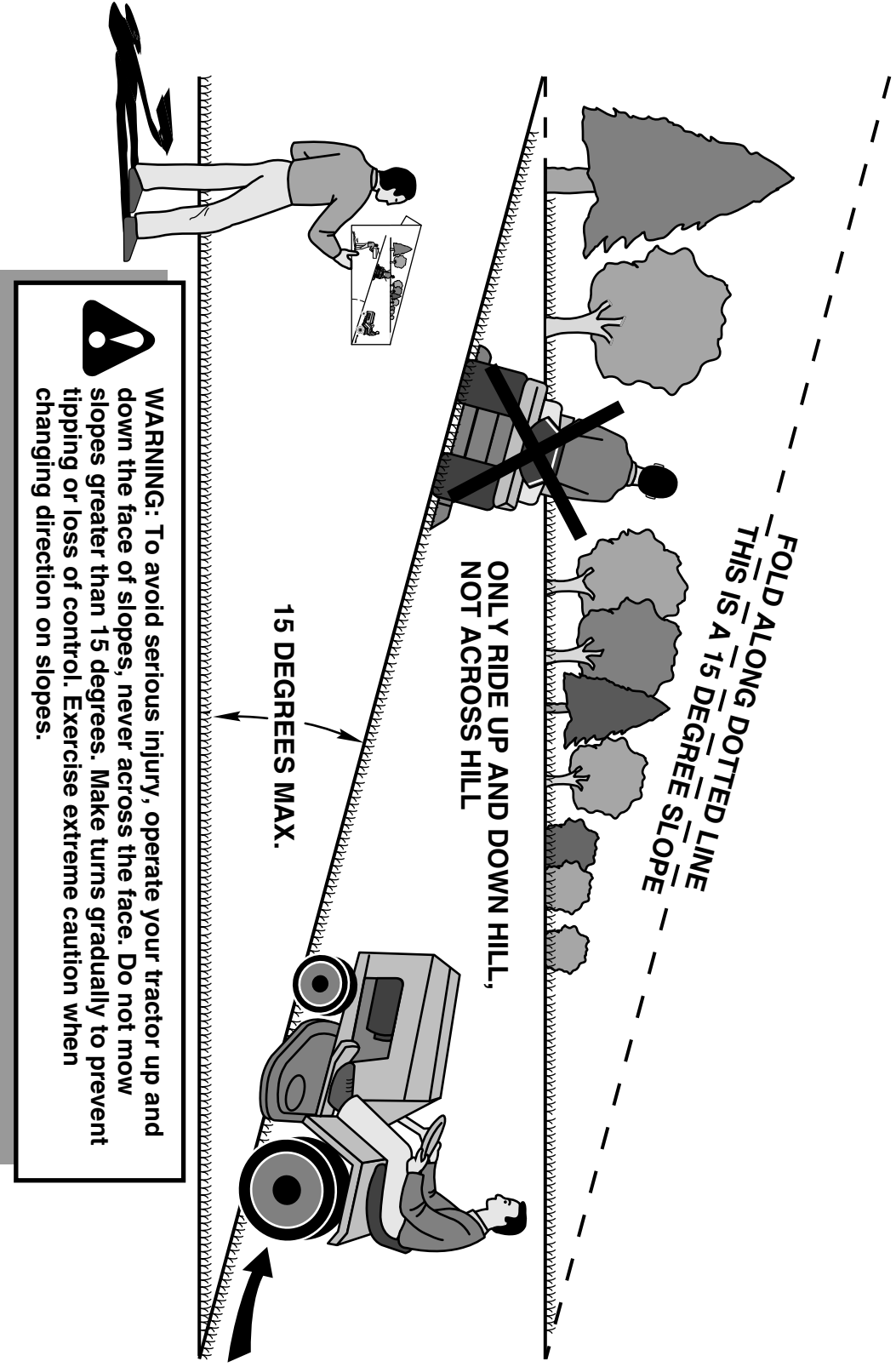

1. Fold this page along dotted line indicated above.
2. Hold page before you so that its left edge is vertically parallel to a tree trunk or other upright structure.
3. Sight across the fold in the direction of hill slope you want to measure.
4. Compare the angle of the fold with the slope of the hill.

WARRANTY STATEMENT

SECTION 1: LIMITED WARRANTY

Husqvarna Forest & Garden Company ("Husqvarna") warrants Husqvarna product to be free from defects in material and workmanship from the date of purchase for the "Warranty Period" of the product as set forth below:
Lifetime Warranty (Parts and Labor): All tiller lines and trimmer shafts against breakage. Proof of purchase required.
Lifetime Warranty ("PARTS ONLY" after initial warranty expiration): Ignition coils and modules on handheld product. Proof of purchase required.

WARRANTY SCHEDULE FOR TURF CARE EQUIPMENT - Zero Turn Riders

(New warranty applies to units sold after August 1, 2005. Also applies to units factory-equipped with R.O.P.S.)

EZ Zero Turn Riders: 3 year consumer warranty or 600 hours of use (when used solely at the owner's residence.)

EZ & MZ Zero Turn Riders: 1 year commercial warranty or 600 hours of use.

IZ, LZ & BZ Zero Turn Riders: 5 year consumer warranty or 1,500 hours of use.

IZ, LZ & BZ Zero Turn Riders: 5 year commercial warranty or 1,500 hours of use.

3 Year or 1,500 Hour Commercial Use Warranty: spindles on zero turn riders, hydraulic pumps and wheel motors.

Warranty Schedule for Turf Care Walk Behind Units - W, WG & WH Zero Turn Riders - 3 year consumer and commercial

warranty. New warranty applies to units sold after August 1, 2005. Also applies to units factory-equipped with R.O.P.S.

2 Year COMMERCIAL and CONSUMER Warranty: all Husqvarna ground-engaging commercial equipment.

WARRANTY SCHEDULE FOR CONSUMER TURF CARE EQUIPMENT:

2 Year Consumer Warranty: Automatic mower, all Residential Zero Turn Riders, all lawn, yard and garden tractors, all

noncommercial walk behind mowers, tillers, snow blowers, electrical products and power-assist collection systems for

noncommercial, nonprofessional, noninstitutional or nonincome producing use, except as herein stated. All consumer

product use must have been limited to the owner's residence.

WARRANTY SCHEDULE FOR CONSUMER FOREST & GARDEN EQUIPMENT:

2 Year Consumer Warranty: all consumer chain saws, trimmers, brushcutters, clearing saws, handheld blowers, backpack

blowers, hedge trimmers, and electrical products for noncommercial, nonprofessional, noninstitutional or nonincome

producing use, except as herein stated. All consumer product use must have been limited to the owner's residence.

2 Year or 2,000 Hour Powertrain & 1 Year or 1,000 Hour Body Warranty: Husqvarna Utility Vehicles.

1 Year Warranty: Power cutters, stump grinder, pole pruners and pole saws for non-commercial, non-professional,

noninstitutional, non-municipality or non-income producing use. All 300 series trimmers, brushcutters, clearing saws,

honing trimmers, stick edgers, backpack blowers, hand held blowers, hedge trimmers, power-assist collection systems for

commercial, institutional, professional or income producing purposes or use.

1 Year Conditional Component Warranty: Chain saw crankshafts for commercial/professional use (parts and labor). Saw

must be operated with Husqvarna XP 2 cycle oil.

90 Day Commercial Warranty: Automatic mower, chain saws, 100 series trimmers, power cutters, stump grinders, pole

saws, pole pruners, snow throwers, model series 580 & 600 walk-behind mowers, or any Husqvarna product used for

commercial, institutional, professional, municipality or income producing purposes or use except as otherwise provided herein.

Batteries: 1 year prorated limited warranty with 100% replacement during the first 6 months.

Rental Warranty: 90 days on all applicable professional equipment reference warranty time period charts

located in the back of the Retailer Warranty Policy & Procedure Manual.

Husqvarna Safety Apparel carries a 90-day warranty from the date of the customer's original purchase for defects in

material and workmanship. Normal wear, tear or abuse is not covered under warranty. Product must be returned to Charlotte

with a warranty claim form. All care and maintenance instructions must be followed as stated by the manufacturer on the

care label. The fit of the protective apparel/boot is not covered under warranty.

30 Day Warranty: Replacement parts, accessories including bars and chains, tools and display items. Emission control

system components necessary to comply with CARB-TIER II and EPA regulations, except for those components which are

part of engine systems manufactured by third part engine manufacturers for which the purchaser has received a separate

warranty with product at time of purchase.

starter ropes and tiller lines;

(2) Natural discoloration of material due to ultraviolet light;

(3) Engine and drive systems not manufactured by Husqvarna; these items are covered by the respective manufacturer's warranty as provided in writing with the product information supplied at the time of purchase; all claims must be sent to the appropriate manufacturer;

(4) Lawn and garden attachments are covered by a third party which gives a warranty, all claims for warranty should be sent to the manufacturer;

(5) Commercial or consumer mowing decks with sand abrasion damage.

(6) Emission Control System components necessary to comply with CARB-TIER II and EPA regulations which are manufactured by third party engine manufacturer.

SECTION 4: EXCEPTIONS AND LIMITATIONS

This warranty shall be inapplicable to defects resulting from the following:

(1) Accident, abuse, misuse, negligence and neglect, including state fuel, dirt, abrasives, moisture, rust, corrosion, or any adverse reaction due to incorrect storage or use habits;

(2) Failure to operate or maintain the unit in accordance with the Owner's/Operator's manual or instruction sheet furnished by Husqvarna;

(3) Alterations or modifications that change the intended use of the product or affects the product's performance, operation, safety, or durability, or causes the product to fail to comply with any applicable laws; or

(4) Additional damage to parts or components due to continued use occurring after any of the above.

REPAIR OR REPLACEMENT AS PROVIDED UNDER THIS WARRANTY IS THE EXCLUSIVE REMEDY OF THE PURCHASER. HUSQVARNA SHALL NOT BE LIABLE FOR ANY INCIDENTAL OR CONSEQUENTIAL DAMAGES FOR BREACH OF ANY EXPRESS OR IMPLIED WARRANTY ON THESE PRODUCTS EXCEPT TO THE EXTENT PROHIBITED BY APPLICABLE LAW. ANY IMPLIED WARRANTY OF MERCHANTABILITY OR FITNESS FOR A PARTICULAR PURPOSE ON THESE PRODUCTS IS LIMITED IN DURATION TO THE WARRANTY PERIOD AS DEFINED IN THE LIMITED WARRANTY STATEMENT. HUSQVARNA RESERVES THE RIGHT TO CHANGE OR IMPROVE THE DESIGN OF THE PRODUCT WITHOUT NOTICE, AND DOES NOT ASSUME OBLIGATION TO UPDATE PREVIOUSLY MANUFACTURED PRODUCTS.

Some states do not allow the exclusion of incidental or consequential damages, or limitations on how long an implied warranty lasts, so the above limitations or exclusions may not apply to you. This warranty gives you specific legal rights, and you may also have other rights which vary from state to state.

SECTION 5: CUSTOMER RESPONSIBILITIES

The product must exhibit reasonable care, maintenance, operation, storage and general upkeep as written in the maintenance section of the Owner's/Operator's manual. Should an operational problem or failure occur, the product should not be used, but delivered as is to an authorized Husqvarna retailer for evaluation. Proof of purchase, as explained in section 6, rests solely with the customer.

SECTION 6: PROCEDURE TO OBTAIN WARRANTY CONSIDERATION

It is the Owner's and Retailer's responsibility to make certain that the Warranty Registration Card is properly filled out and mailed to Husqvarna Forest & Garden Company. This card should be mailed within ten (10) days from the date of purchase in order to confirm the warranty and to facilitate post-sale service.

Proof of purchase must be presented to the authorized Husqvarna retailer in order to obtain warranty service. This proof must include date purchased, model number, serial number, and complete name and address of the selling retailer.

To obtain the benefit of this warranty, the product believed to be defective must be delivered to an authorized Husqvarna retailer in a timely manner, no later than thirty (30) days from date of the operational problem or failure. The product must be delivered at the owner's expense. Downtime, pick-up and delivery charges are not covered by this warranty. An authorized Husqvarna retailer can be normally located through the "Yellow Pages" of the local telephone directory or by calling 1-800-HUSKY62 for a retailer in your area.

HUSQVARNA

9335 Harris Corners Parkway

Charlotte, NC 28269

2008

SECTION 2: HUSQVARNA'S OBLIGATIONS UNDER THE WARRANTY

Husqvarna will repair or replace defective components without charge for parts or labor if a component fails because of a defect in material or workmanship during the warranty period.

SECTION 3: ITEMS NOT COVERED BY THIS WARRANTY

The following items are not covered by this warranty:

(1) Normal customer maintenance items which become worn through normal regular use, including, but not limited to, belts, blades, blade adapters, bulbs, clutches, clutch drums, filters, guide bars, lubricants, rewind springs, saw chain, spark plugs,