

# **917.289542**

## **(YTH20K46)**

**Owner's Manual**

# TRACTOR -- MODEL NUMBER 917.289542, PRODUCT NO. YTH20K46

## SCHEMATIC

SCH10

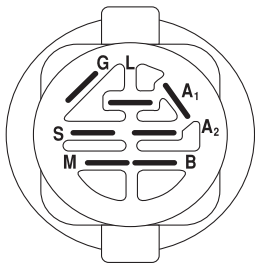
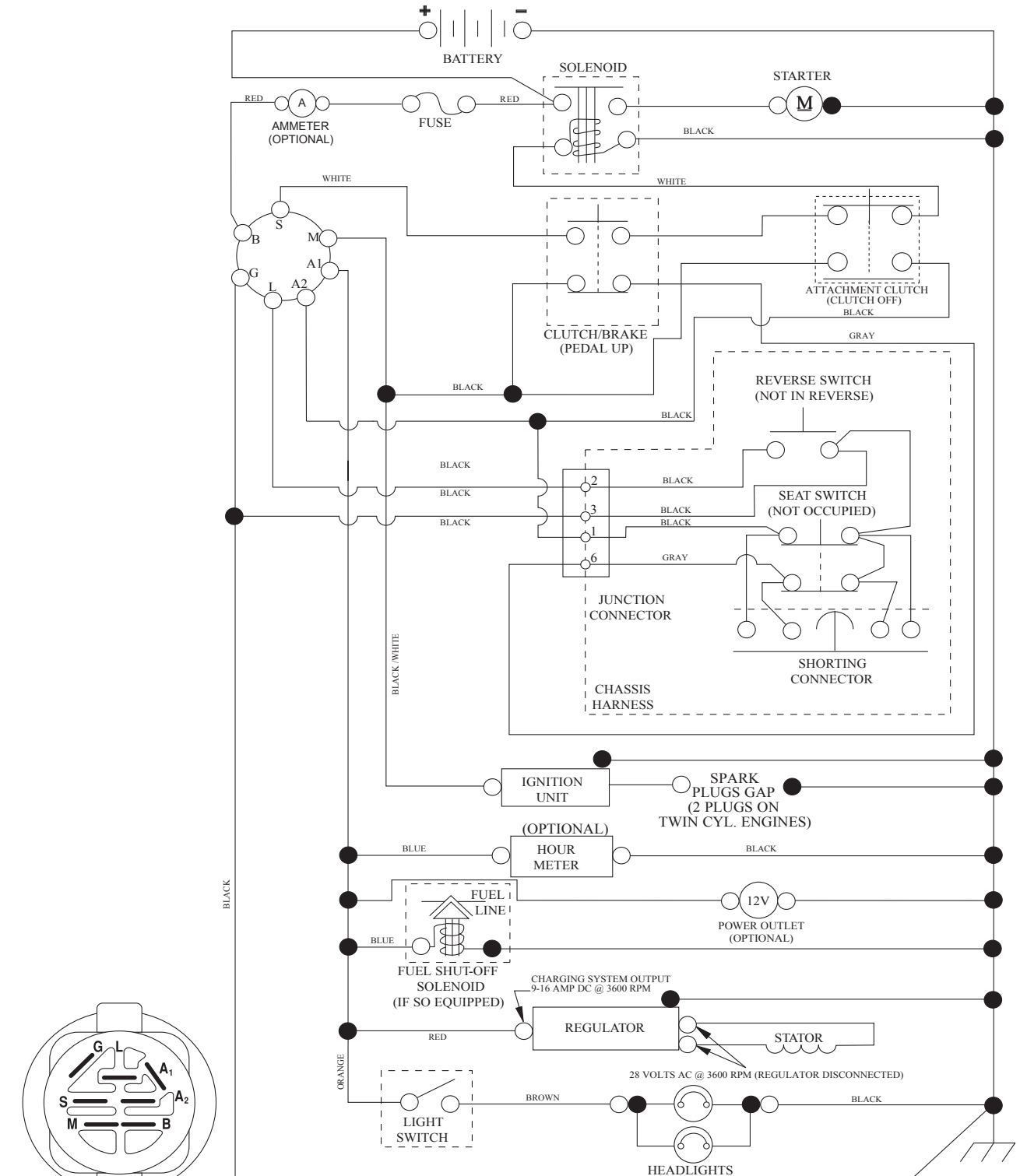

IGNITION SWITCH

POSITION	CIRCUIT	"MAKE"
OFF	M+G+A1	
RUN/OVERRIDE	B+A1	
RUN	B+A1	L+A2
START	B + S + A1	

03107

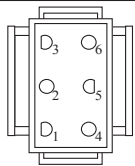

CHASSIS HARNESS CONNECTOR (MATING SIDE)

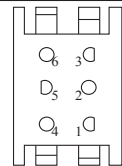

DASH HARNESS CONNECTOR (MATING SIDE)

WIRING INSULATED CLIPS  
NOTE: IF WIRING INSULATED CLIPS WERE REMOVED FOR SERVICING OF UNIT, THEY SHOULD BE RE-INSTALLED TO PROPERLY SECURE YOUR WIRING.

●  
NON-REMOVABLE CONNECTIONS

○  
REMOVABLE CONNECTIONS

**TRACTOR - - MODEL NUMBER 917.289542, PRODUCT NO. YTH20K46**  
**ELECTRICAL**

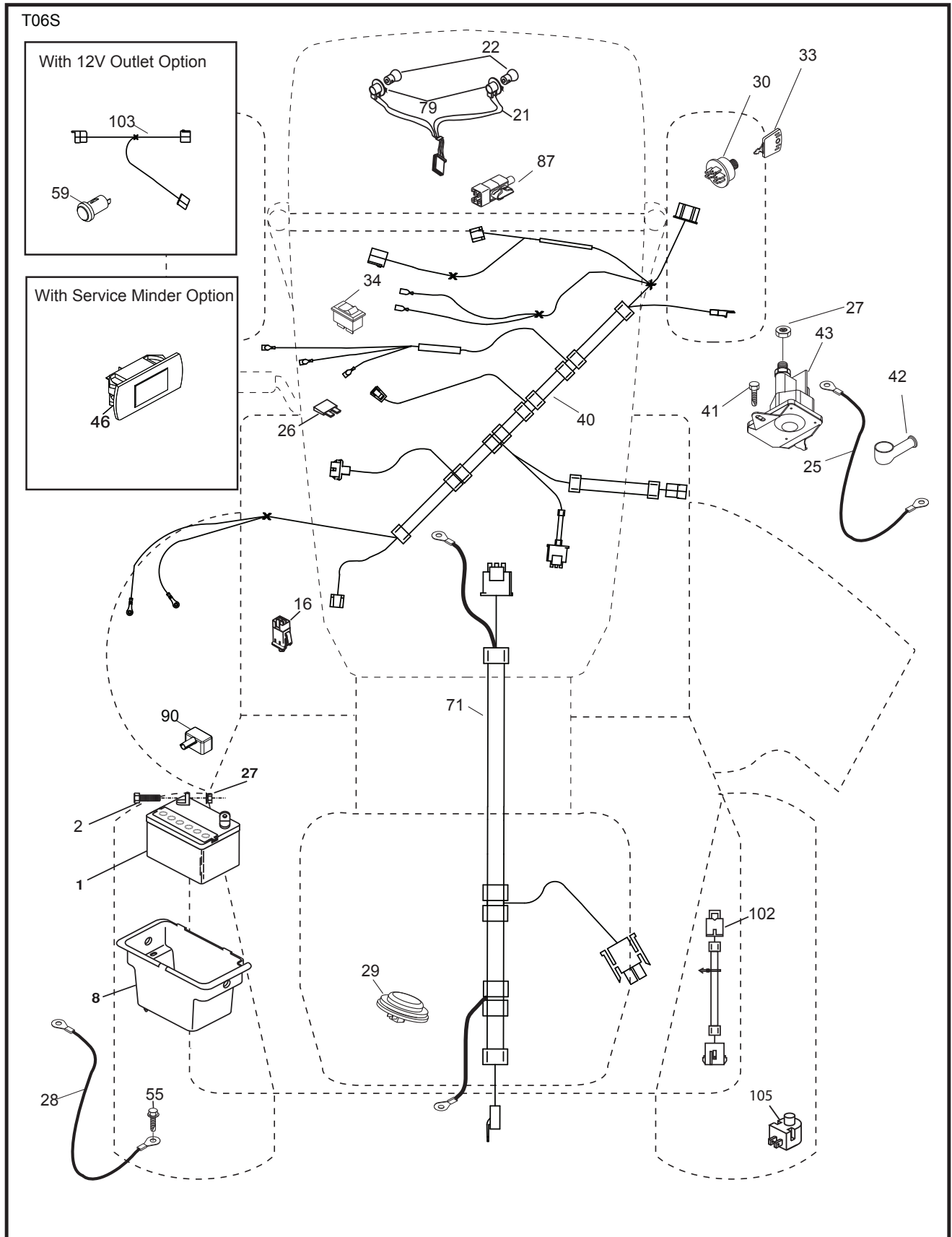

**TRACTOR - - MODEL NUMBER 917.289542, PRODUCT NO. YTH20K46  
ELECTRICAL**

<b>KEY NO.</b>	<b>PART NO.</b>	<b>DESCRIPTION</b>
1	532 16 34-65	Battery
2	874 76 04-12	Bolt Hex Head 1/4-20 x 3/4
8	532 19 32-28	Box Battery
16	532 17 61-38	Switch Interlock Push-In
21	532 40 02-52	Harness Socket Light w/4152J
22	532 00 41-52	Bulb Light
25	532 41 28-95	Cable Starter
26	532 17 51-58	Fuse
27	873 51 04-00	Nut Keps Hex 1/4-20 unc
28	532 19 88-85	Cable, Ground
29	532 40 15-45	Switch, Seat
30	532 19 33-50	Switch, Ign
33	532 41 19-35	Key / Chain
34	532 11 07-12	Switch Light / Reset
40	532 40 04-49	Harness Ign.
41	817 72 04-08	Screw Thd Cut 1/4-20 x 1/2
42	532 13 15-63	Cover, Terminal
43	532 19 25-07	Solenoid
46	532 40 17-63	Gauge Hourmeter
55	817 06 05-12	Screw Thdrol 5/16-18 x 3/4 TYTT
71	532 40 10-98	Harness Ign. Dash
79	532 17 52-42	Socket Asm. Bulb Twistlock
87	532 19 78-02	Switch Interlock Clutch Cable
90	532 40 07-25	Cover Terminal
102	532 40 44-54	Harness Pigtail
105	532 40 75-68	Switch Reverse TT GT

**NOTE:** All component dimensions given in U.S. inches  
1 inch = 25.4 mm



**TRACTOR - - MODEL NUMBER 917.289542, PRODUCT NO. YTH20K46**  
**CHASSIS**

<b>KEY NO.</b>	<b>PART NO.</b>	<b>DESCRIPTION</b>
3	532 43 07-71	Logo Crown
5	532 40 87-03	Dash
14	532 41 10-46	Hood
15	532 19 89-07	Lens LH
18	532 40 86-07	Grille/Lens Asm.
25	532 19 89-06	Lens RH
34	532 19 61-25	Plate Engine
36	817 06 05-12	Screw 5/16-18 x 3/4
37	532 41 87-14	Fender
52	873 68 05-00	Nut Lock 5/16-18
58	532 41 22-80	Drawbar Upper
68	817 49 05-08	Screw Thdrol 5/16-18 x 1/2
130	532 41 63-58	Screw #10 x 0.750 BOS Thread
137	532 40 75-90	Bumper Dash
138	532 40 29-54	Cupholder
150	532 19 85-13	Air Duct
152	532 19 95-35	Shield Browning
159	817 00 06-12	Screw Hexwsh Thdr 3/8-16 x 3/4
162	532 14 24-32	Screw
175	532 19 63-04	Crossmember
176	532 40 07-76	Screw 10-24 x 5/8
177	532 19 52-27	Bushing Steering
178	532 19 97-82	Cargo Net Asm.
180	532 41 50-63	Chassis
181	532 40 30-25	Bushing Mtg. Fender Crgo
182	532 40 68-59	Dash Lower
183	874 52 05-20	Bolt 5/16-18 x 1-1/4 Full Thread
189	817 00 05-12	Screw 5/16-18 x 3/4
194	873 90 05-00	Nut Lock Hex Flange 5/16-18
195	532 40 41-37	Plug Hole Dash Lower
196	532 41 45-80	Console Asm. Deck Lift
202	532 40 30-48	Vent Side Hood RH
203	532 40 30-76	Vent Side Hood LH
204	532 41 66-13	Vent Top Hood
205	532 40 17-09	Skirt Hood Side RH
206	532 40 17-11	Skirt Hood Side LH
207	532 19 71-98	Bezel RH
208	532 19 71-99	Bezel LH
209	532 19 91-30	Insert Hex Top RH
210	532 19 91-31	Insert Hex Top Lh
211	532 19 91-32	Insert Hex Bottom RH
212	532 19 91-33	Insert Hex Bottom LH
213	874 76 05-12	Bolt 5/16-18 x 3/4
214	532 19 91-45	Clip Retainer Tinner
217	532 40 91-67	Rod Pivot
218	532 19 63-95	X-Piece Hood Stop
228	532 19 51-61	Stud Fastner
234	532 40 47-42	Bumper Hood
235	532 40 61-29	Spacer Fender
236	873 93 05-00	Nut Lock 5/16-18 unc
238	532 40 86-06	Trim Husq.
287	817 60 04-06	Screw Hex Washhead 1/4-20 x 3/8
298	532 11 04-52	Nut Push

**NOTE:** All component dimensions given in U.S. inches  
1 inch = 25.4 mm

# TRACTOR - - MODEL NUMBER 917.289542, PRODUCT NO. YTH20K46 DRIVE

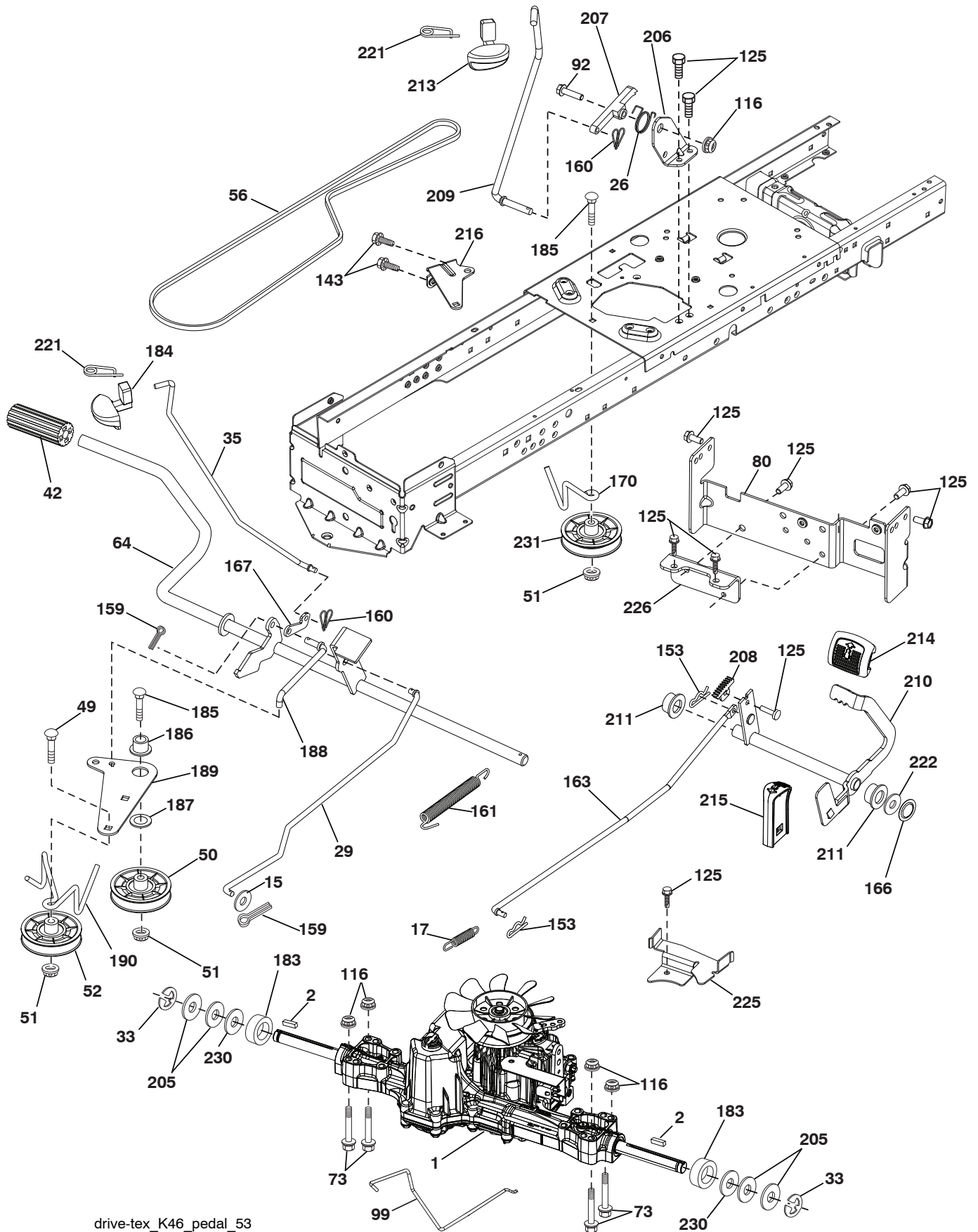

drive-tex\_K46\_pedal\_53

# TRACTOR - - MODEL NUMBER 917.289542, PRODUCT NO. YTH20K46

## DRIVE

KEY NO.	PART NO.	DESCRIPTION
1	-----	Transaxle, TUFFTORQ K46 BT (See Transaxle breakdown)
2	532 12 35-83	Key
15	819 13 13-16	Washer 13/32 x 13/16 x 16 Ga.
17	532 41 36-78	Spring, Brake
26	532 19 96-79	Spring Return Cruise
29	532 40 38-06	Rod, Brake
33	812 00 00-01	Ring E
35	532 19 95-91	Rod, Brake, Park
42	532 12 48-72	Cover, Foot Pedal
49	872 11 06-14	Bolt
50	532 19 43-27	Pulley Idler Flat
51	873 90 06-00	Lock Nut 3/8-16
52	532 19 43-26	Idler V-Groove 910" Offset
56	532 13 09-69	V-Belt, Drive
64	532 19 78-65	Shaft Asm. Pedal Brake Control
73	874 49 05-44	Bolt Hex Flghd 5/16-18 Gr. 5
80	532 41 00-24	Bracket Strap Torque
92	874 76 05-20	Bolt Fin Hex 5/16-18 unc x 1.25
99	532 41 57-42	Rod Spring Bypass
116	873 90 05-00	Nut Lock Hex Flange 5/16-18
125	817 00 05-12	Screw 5/16-18 x 3/4
143	817 49 05-08	Screw 5/16-18 x 1/2
153	532 12 47-88	Retainer Spring
159	876 02 04-12	Pin Cotter 1/8 x 3/4
160	532 16 94-84	Retainer Clip
161	532 10 57-09	Spring, Return, Clutch
163	532 40 10-34	Rod Pedal Control
166	532 42 91-64	Nut Push
167	532 40 52-57	Latch Brake Parking
170	532 41 34-30	Keeper Belt Centerspan

KEY NO.	PART NO.	DESCRIPTION
183	532 13 70-57	Spacer Axle
184	532 40 31-18	Handle Parking Brake
185	872 11 06-22	Bolt Rdhd 3/8-16 unc x 2-3/4 Gr. 5
186	532 19 43-21	Spacer Retainer
187	819 13 32-10	Washer
188	532 19 43-23	Link Clutch Ground Drive
189	532 19 43-17	Bellcrank Ground Drive
190	532 19 43-18	Keeper Bellcrank Ground Drive
205	532 12 17-48	Washer
206	532 19 78-67	Bracket Mount Latch Cruise
207	532 19 78-68	Latch Control Cruise
208	532 19 78-69	Gear Sector Control Cruise
209	532 19 95-92	Rod Control Cruise
210	532 40 09-80	Rocker Asm. Pedal Control
211	532 12 01-83	Bearing Nylon
213	532 40 31-19	Knob Control Cruise
214	532 42 12-63	Pedal Forward
215	532 40 17-23	Pedal Reverse
216	532 19 61-31	Bracket Pulley Idler
221	532 40 31-87	Retainer Spring Clip Handle
222	879 21 20-10	Washer 21/32 x 1-1/4 10 Ga.
225	532 40 33-19	Keeper Belt Trans.
226	532 40 15-64	Bracket Mount Torque
230	532 18 89-67	Washer Hardened
231	532 40 72-87	Idler V-Groove 1.688" Offset

**NOTE:** All component dimensions given in U.S. inches  
1 inch = 25.4 mm



TRACTOR - - MODEL NUMBER 917.289542, PRODUCT NO. YTH20K46  
ENGINE

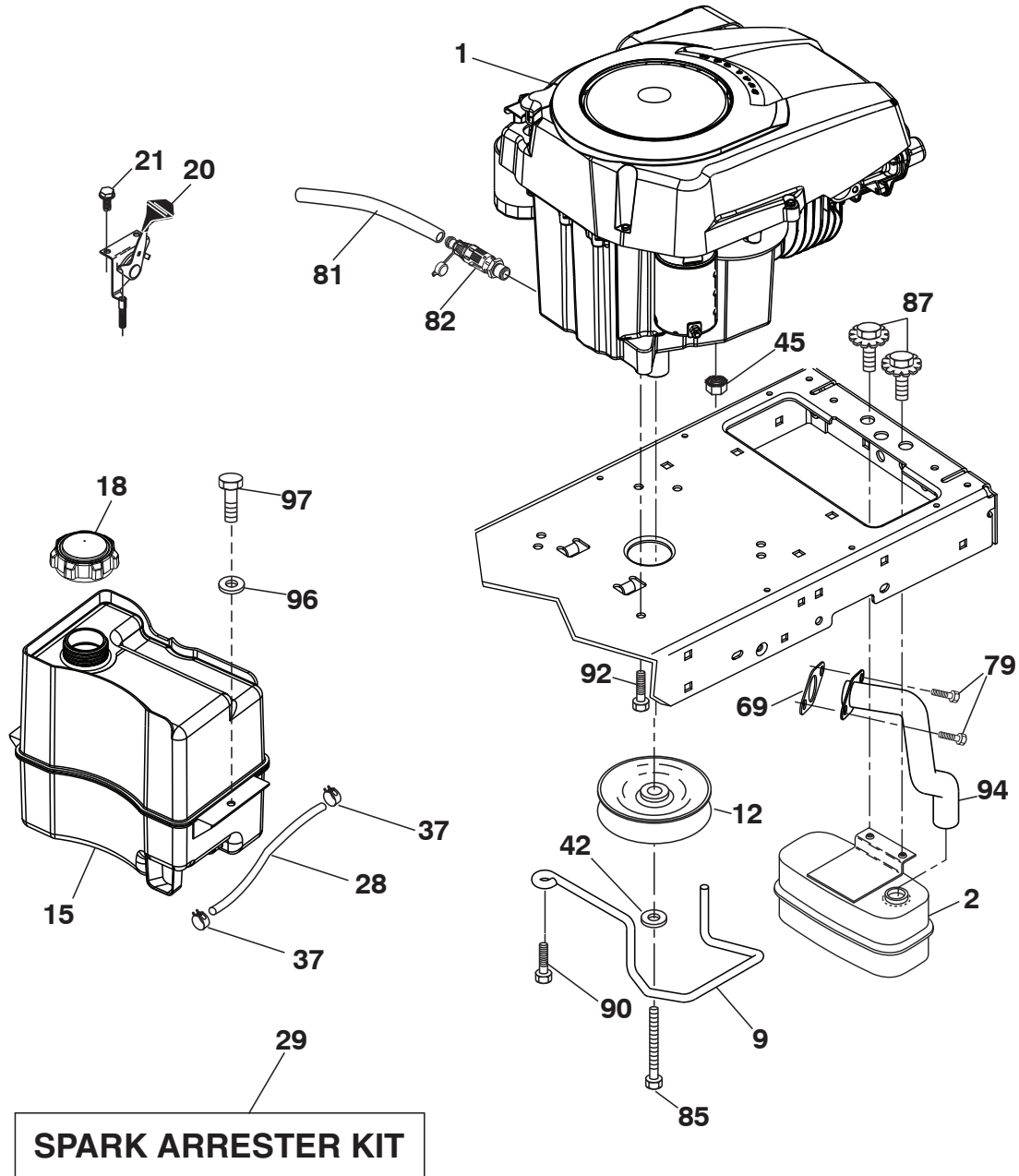

engine-tex\_Kohl\_20\_r1

**TRACTOR - - MODEL NUMBER 917.289542, PRODUCT NO. YTH20K46  
ENGINE**

<b>KEY NO.</b>	<b>PART NO.</b>	<b>DESCRIPTION</b>
1	-----	Engine Kohler Model No. SV600-0212
2	532 18 86-55	Muffler
9	532 19 43-20	Keeper Belt Engine
12	532 40 54-72	Pulley Engine
15	532 40 74-89	Tank Fuel
18	532 43 02-20	Cap Asm
20	532 40 15-08	Control Throttle/Choke
21	532 41 63-58	Screw #10 x 0.750 BOS Thread
28	532 40 11-37	Fuel Line
29	532 13 71-80	Spark Arrester Kit
37	532 12 34-87	Clamp Hose
42	810 04 07-00	Washer Lock 7/16
45	873 51 04-00	Nut Keps Hex 1/4-20 unc
69	532 18 59-09	Gasket
79	532 19 23-34	Screw Socket Head
81	532 14 84-56	Tube Drain Oil Easy
82	532 42 82-87	Valve Drain Oil
85	532 17 39-37	Bolt Hex 7/16-20 x 4 x Gr. 5-1.5 Thr
87	532 17 18-77	Bolt 5/16-18 unc x 3/4 w/Sems
90	817 00 06-16	Screw 3/8-16 x 1
92	817 12 06-16	Screw 3/8-16 x 1
94	532 18 86-54	Tube Exhaust
96	819 09 14-16	Washer 9/32 x 7/8 x 16 Ga.
97	817 67 04-12	Screw Hexwsh Thdrol 1/4-20 x 3/4

**NOTE:** All component dimensions given in U.S. inches  
1 inch = 25.4 mm

For engine service and replacement parts, call the toll free number for your engine manufacturer listed below:

Kohler Co. 1-800-544-2444

# TRACTOR - - MODEL NUMBER 917.289542, PRODUCT NO. YTH20K46

## STEERING ASSEMBLY

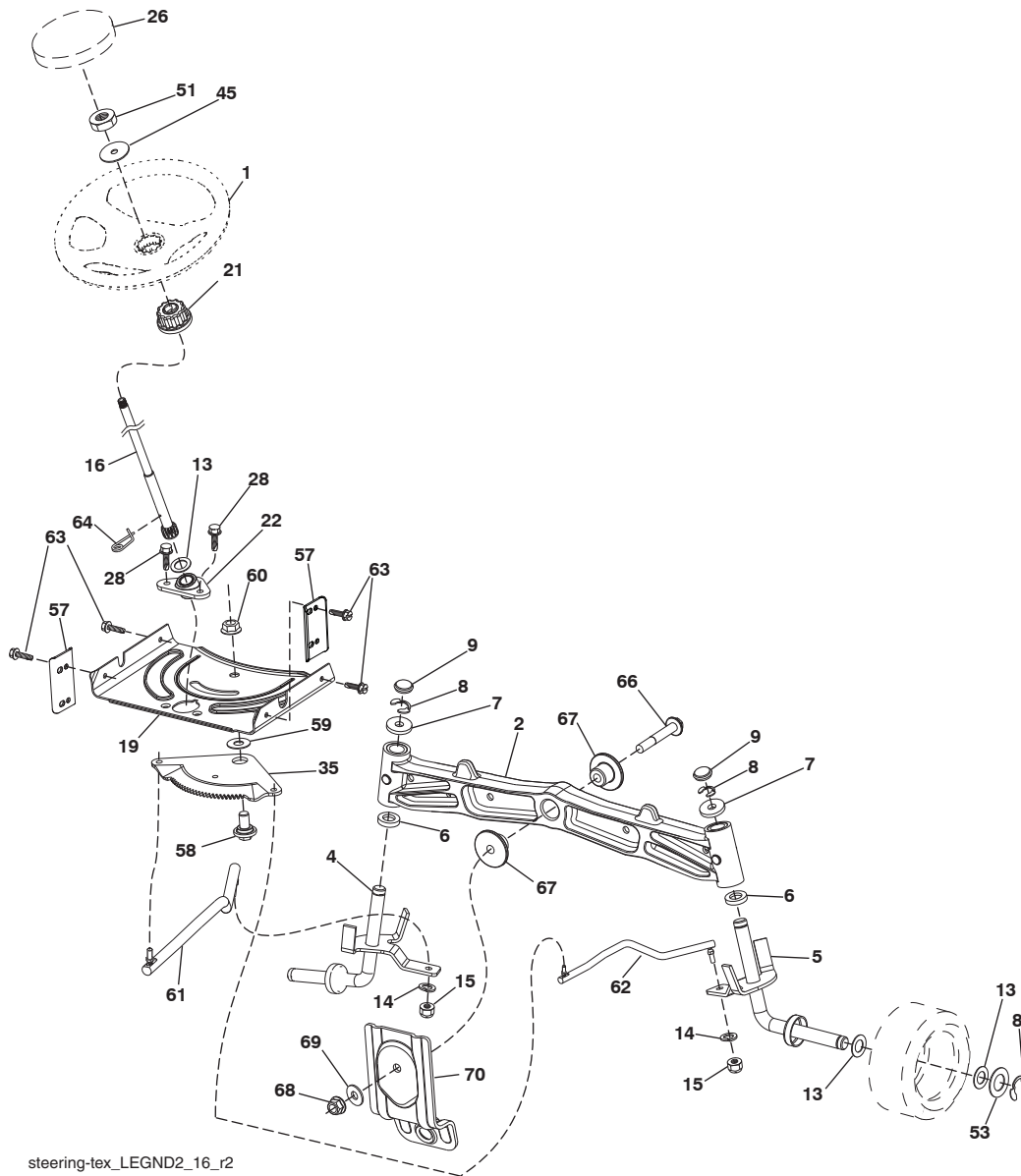

steering-tex\_LEGND2\_16\_r2

KEY NO.	PART NO.	DESCRIPTION	KEY NO.	PART NO.	DESCRIPTION
1	532 41 64-80	Wheel, Steering	51	873 94 08-00	Nut Hex Jam Toplock 1/2-20 unf
2	532 19 59-68	Axle Asm., Front	53	532 18 89-67	WasherHardened.793x1.637x.060
4	532 40 30-87	Spindle Asm., LH	57	532 40 74-65	Bracket Upstop
5	532 40 30-88	Spindle Asm., RH	58	532 19 47-47	Bolt Shoulder Sector Pivot CFM
6	532 12 49-31	Bearing, Race Thrust Harden	59	532 19 47-48	Washer Thrust Sector Steering
7	532 12 17-48	Washer 25/32 x 1-5/8 x 16 Ga.	60	873 97 10-00	Nut Flange Lock 5/8-11
8	812 00 00-29	Ring, Klip #T5304-75	61	532 19 47-40	Draglink LH
9	532 12 12-32	Cap, Spindle	62	532 19 47-41	Draglink, RH
13	532 12 17-49	Washer 25/32 x 1-1/4 x 16 Ga.	63	817 00 05-12	Screw 5/16-18 x 3/4
14	810 04 06-00	Washer, Lock Hvy Hlcl Spr 3/8	64	532 19 98-49	Retainer Clip Spring Steering
15	873 54 06-00	Nut, Crown Lock 3/8-24 unf	66	871 02 07-48	Bolt Hex Fghd 7/16-14 x 3 Serr
16	532 40 82-19	Shaft Steering	67	532 19 47-37	Bushing PM Front Axle
19	532 19 47-29	Plate Steering	68	873 90 07-00	Nut Lock Flange 7/16-14 Gr. 5
21	532 18 67-37	Adapter, Wheel Steering	69	532 19 91-62	Washer 1.5 x .505 x .118
22	532 42 05-37	Support Strg. Lower	70	532 19 61-97	Bracket Deck Susp. Front
26	532 41 59-87	Insert, Wheel Steering			
28	817 00 06-12	Screw 3/8-16 x 3/4			
35	532 19 47-32	Gear, Sector Plate			
45	819 18 38-12	Washer9/16 ID x 2-3/8 OD 12 Ga.			

**NOTE:** All component dimensions given in U.S. inches  
1 inch = 25.4 mm

**TRACTOR - - MODEL NUMBER 917.289542, PRODUCT NO. YTH20K46  
SEAT ASSEMBLY**

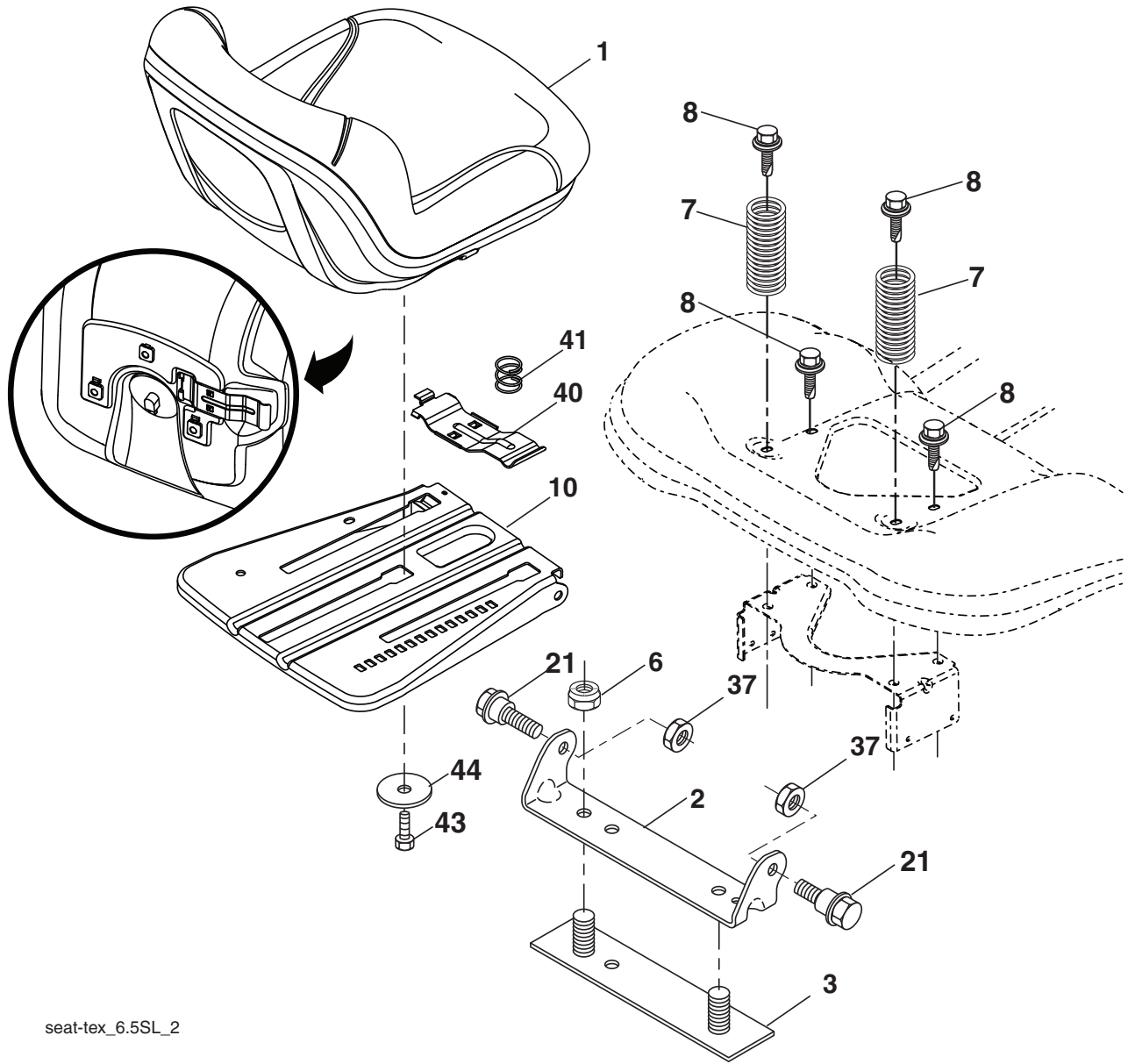

seat-tex\_6.5SL\_2

KEY NO.	PART NO.	DESCRIPTION
1	532 42 40-68	Seat
2	532 18 01-66	Bracket Pivot Fender
3	532 14 06-75	Strap, Asm Fender
6	873 80 06-00	Nut, Lock w/Ins. 3/8-16 unc
7	532 12 41-81	Spring, Seat Cprsn
8	532 17 18-77	Bolt 5/16-18 unc x 3/4 w/Sems
10	532 19 69-77	Pan, Seat
21	532 17 18-52	Bolt, Shoulder 5/16-18

KEY NO.	PART NO.	DESCRIPTION
37	873 80 05-00	Nut, Lock 5/16-18 unc
40	532 19 76-61	Handle Slide Seat
41	532 19 82-00	Spring Latch Seat
43	874 76 06-12	Bolt Fin Hex 3/8-16 unc x 3/4
44	819 13 38-12	Washer 13/32 x 2-3/8 x 12 Ga.

**NOTE:** All component dimensions given in U.S. inches  
1 inch = 25.4 mm

# TRACTOR - - MODEL NUMBER 917.289542, PRODUCT NO. YTH20K46

## MOWER DECK

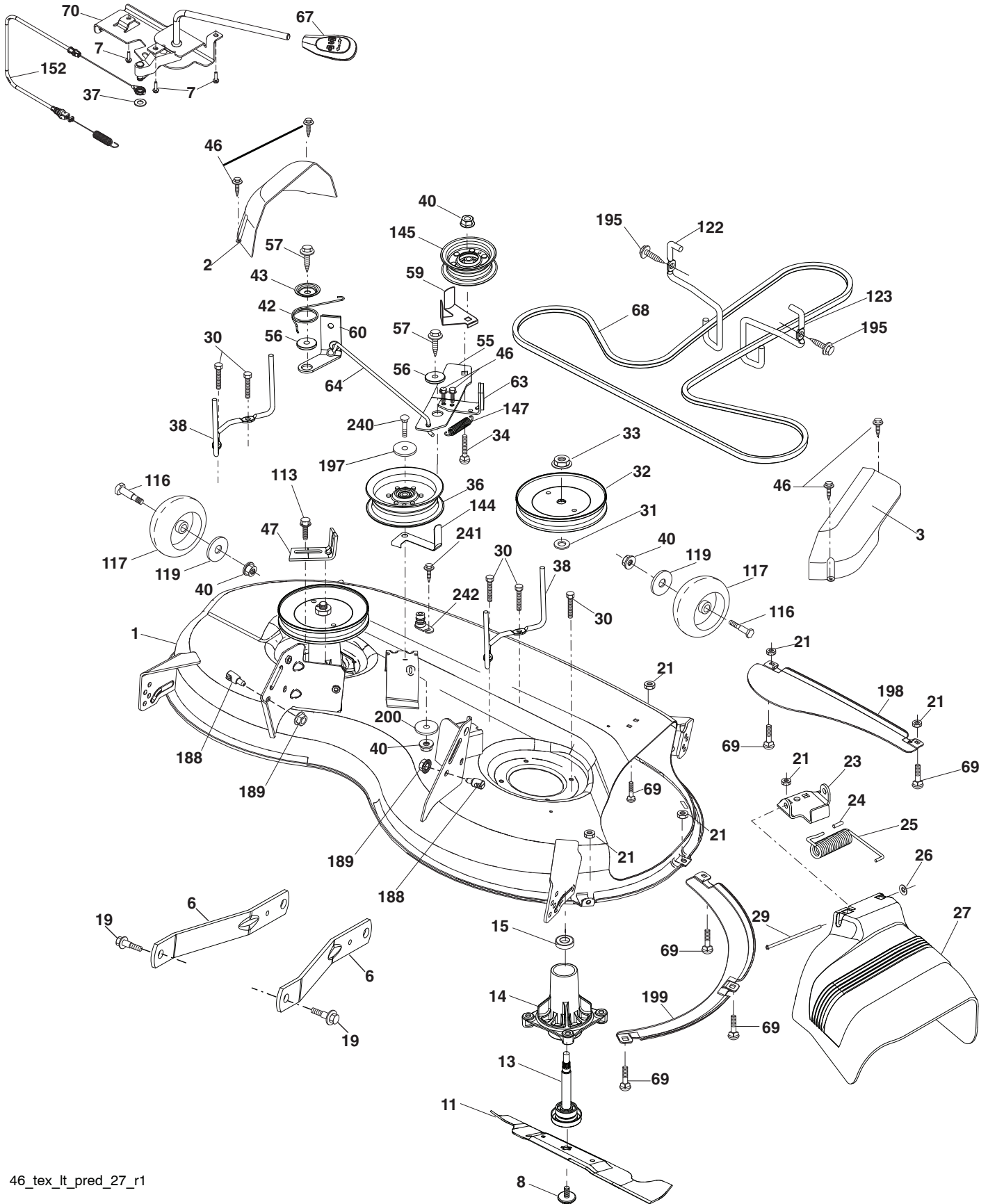

46\_tex\_lt\_pred\_27\_r1

**TRACTOR - - MODEL NUMBER 917.289542, PRODUCT NO. YTH20K46  
MOWER DECK**

<b>KEY PART NO. NO.</b>	<b>DESCRIPTION</b>	<b>KEY PART NO. NO.</b>	<b>DESCRIPTION</b>
1 532 41 08-63	Mower Housing	60 532 19 94-71	Arm Brake Mower LH
2 532 40 55-06	Cover Mandrel RH	63 532 19 94-77	Arm Brake Mower
3 532 40 55-07	Cover Mandrel LH	64 532 40 51-38	Linkage Brake
6 532 19 51-86	Arm Suspension	67 532 40 30-12	Handle, Clutch Cable
7 532 41 63-58	Screw #10 x 0.750 BOS Thread	68 532 40 51-43	V-Belt
8 532 19 30-03	Bolt/Washer asm 7/16-20 unf	69 872 14 05-05	Bolt
11 532 40 53-80	Blade Mower	70 532 40 65-63	Clutch Asm. Cable
- - 532 40 31-07	Blade, 46" Mulching	113 817 00 05-10	Screw 5/16-18
13 532 19 28-72	Shaft Assembly, Mandrel	116 532 19 34-06	Bolt, Shoulder
14 532 18 72-81	Housing, Mandrel	117 532 17 48-73	Wheel, Gauge
15 532 11 04-85	Bearing, Ball, Mandrel	119 819 13 20-12	Washer 13/32 x 1-1/4 x 12 Ga.
19 532 19 65-39	Bolt, Shoulder	122 532 19 72-58	Keeper Belt Eng. LH
21 873 68 05-00	Nut	123 532 19 72-59	Keeper Belt Eng. RH
23 532 19 25-57	Bracket, Deflector	144 532 19 92-04	Keeper Belt
24 532 10 53-04	Cap, Sleeve	145 532 19 31-97	Pulley Idler
25 532 19 70-26	Spring, Torsion, Deflector	147 532 40 18-72	Spring Return
26 532 11 04-52	Nut, Push	152 532 40 83-19	Cable Clutch Manual w/Spr.
27 532 40 53-57	Shield, Deflector	188 532 19 51-61	Stud Fastener
29 532 13 14-91	Rod, Hinge	189 873 90 05-00	Nut Lock Hex Flange
30 532 17 39-84	Screw Thdrol Rolling Wsh Hd	195 817 00 06-12	Screw 3/8-16 x 3/4
31 532 18 76-90	Washer, Spacer	197 819 13 13-12	Washer 13/32 x 13/16 x 12 Ga.
32 532 19 74-73	Pulley, Mandrel	198 532 40 31-49	Baffle Center Front
33 532 40 02-34	Nut, Toplock, Flanged	199 532 40 31-50	Baffle Front RH
34 872 11 06-12	Bolt Carr Sh. 3/8-16 x 1-1/2 Gr. 5	200 532 41 35-24	Washer 13/32 x 1 x 1/2 Ga.
36 532 19 73-79	Pulley, Idler, 4.50 RAW	240 874 52 06-36	Bolt 3/8-16 unc x 2-1/4 Gr. 5
37 819 13 13-16	Washer 13/32 x 13/16 x 16 Ga.	241 532 15 29-27	Screw TT #10-32.5 3/8 Flg.
38 532 43 25-20	Keeper Belt Mandrel	242 532 41 55-98	Port Washout
40 873 90 06-00	Nut, Lock Flg. 3/8-16 unc	- - 532 19 28-70	Mandrel Assembly (Includes hous- ing, shaft assembly, and bearing only - pulley/nut/washer and blade bolt/washers not included)
42 532 19 84-10	Spring Trosion Brake		
43 532 19 72-56	Spring Torsion Retainer		
46 532 13 77-29	Screw		
47 532 19 72-50	Bracket Clutch Cable	- - 532 43 18-23	Replacement Mower, Complete
55 532 19 72-49	Arm, Idler		
56 532 19 90-92	Spacer, Retainer		
57 817 00 06-16	Screw Hexwsh Thd 3/8-16 x 1		
59 532 14 10-43	Guard, Tuv Idler (94)		

**NOTE:** All component dimensions given in U.S. inches  
1 inch = 25.4 mm

**TRACTOR - - MODEL NUMBER 917.289542, PRODUCT NO. YTH20K46  
DECALS**

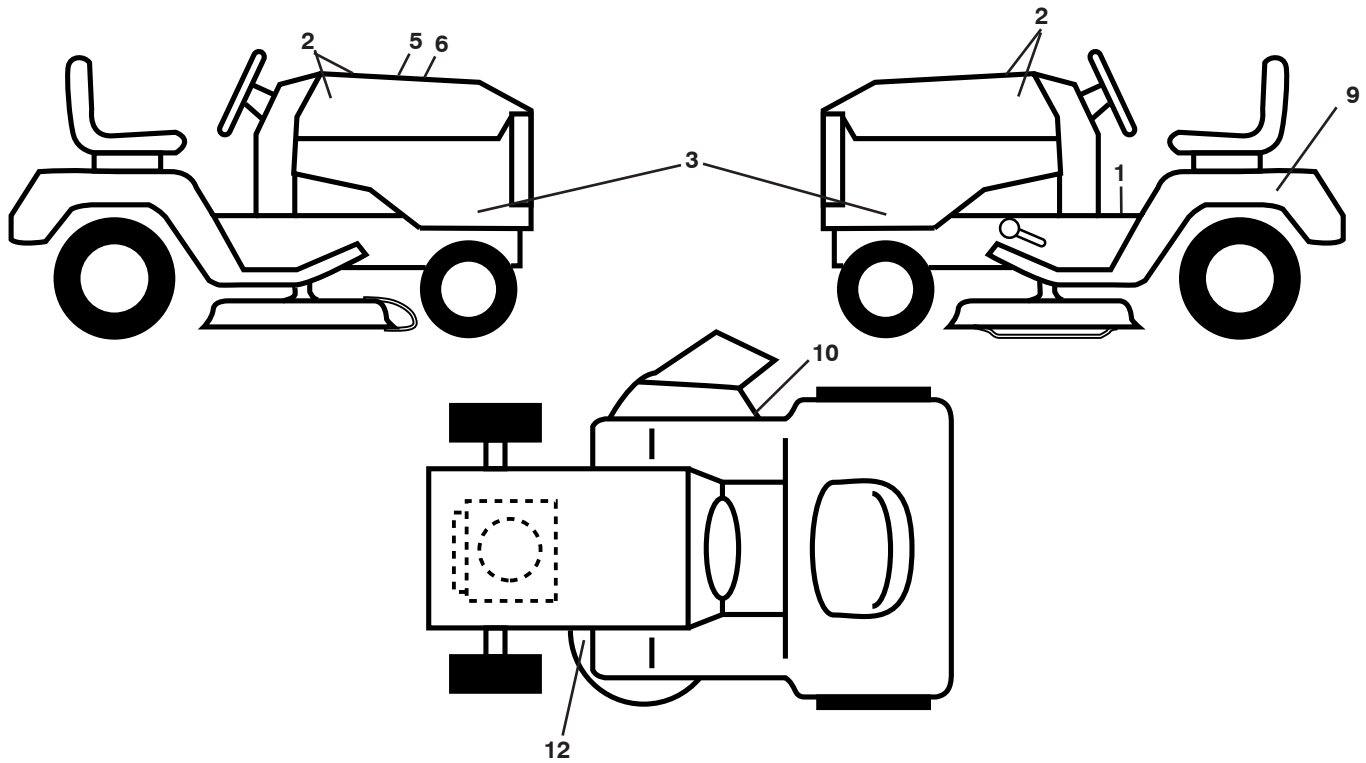

KEY NO.	PART NO.	DESCRIPTION	KEY NO.	PART NO.	DESCRIPTION
1	532 41 16-58	Decal, Operators	12	532 16 03-96	Decal, Mower V-Belt Schematic
2	532 42 91-96	Decal, Badge	--	532 16 69-60	Decal, Bypass
3	532 41 01-08	Decal, Hood Panel SD	--	532 41 08-05	Pad, Footrest, LH
5	532 42 38-29	Decal, Customer Respons.	--	532 41 08-06	Pad, Footrest, RH
6	532 43 47-88	Decal, Replacement	--	532 43 47-97	Manual, Owner's (English)
9	532 14 50-05	Decal, Battery Dnge/Poi	--	532 43 47-98	Manual, Owner's (French)
10	532 17 05-63	Decal, Warning			

**WHEELS AND TIRES**

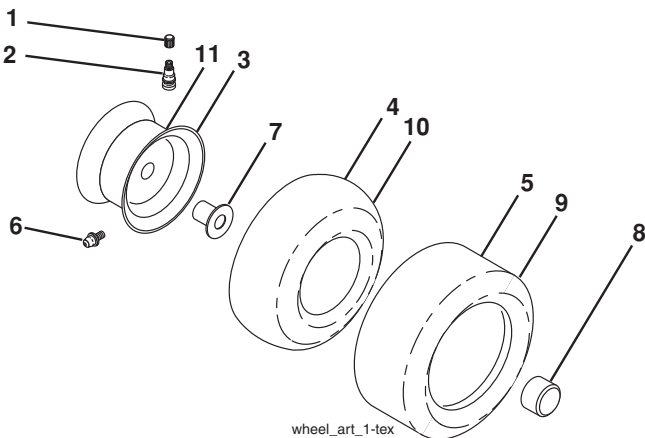

KEY NO.	PART NO.	DESCRIPTION
1	532 05 91-92	Cap Valve Tire
2	532 06 51-39	Stem Valve
3	532 13 83-36	Rim Front Service
4	532 05 99-04	Tube Front (Service Item Only)
5	532 10 62-22	Tire Front 15 x 6.0-6 Service
6	532 12 49-57	Fitting Grease (Front Wheel Only)
7	532 12 49-59	Bearing Flange (Front Wheel Only)
8	532 17 50-39	Cap Axle Blk 1 50 x 1 00
9	532 42 05-31	Tire R T 18 x 9.5-8 Turf Saver LT
10	532 12 49-26	Tube Rear (Service Item Only)
11	532 13 83-37	Rim Asm 8" rear Service
--	532 14 43-34	Sealant, Tire (10 oz. Tube)

**NOTE:** All component dimensions given in U.S. inches  
1 inch = 25.4 mm

**TRACTOR - - MODEL NUMBER 917.289542, PRODUCT NO. YTH20K46  
MOWER LIFT**

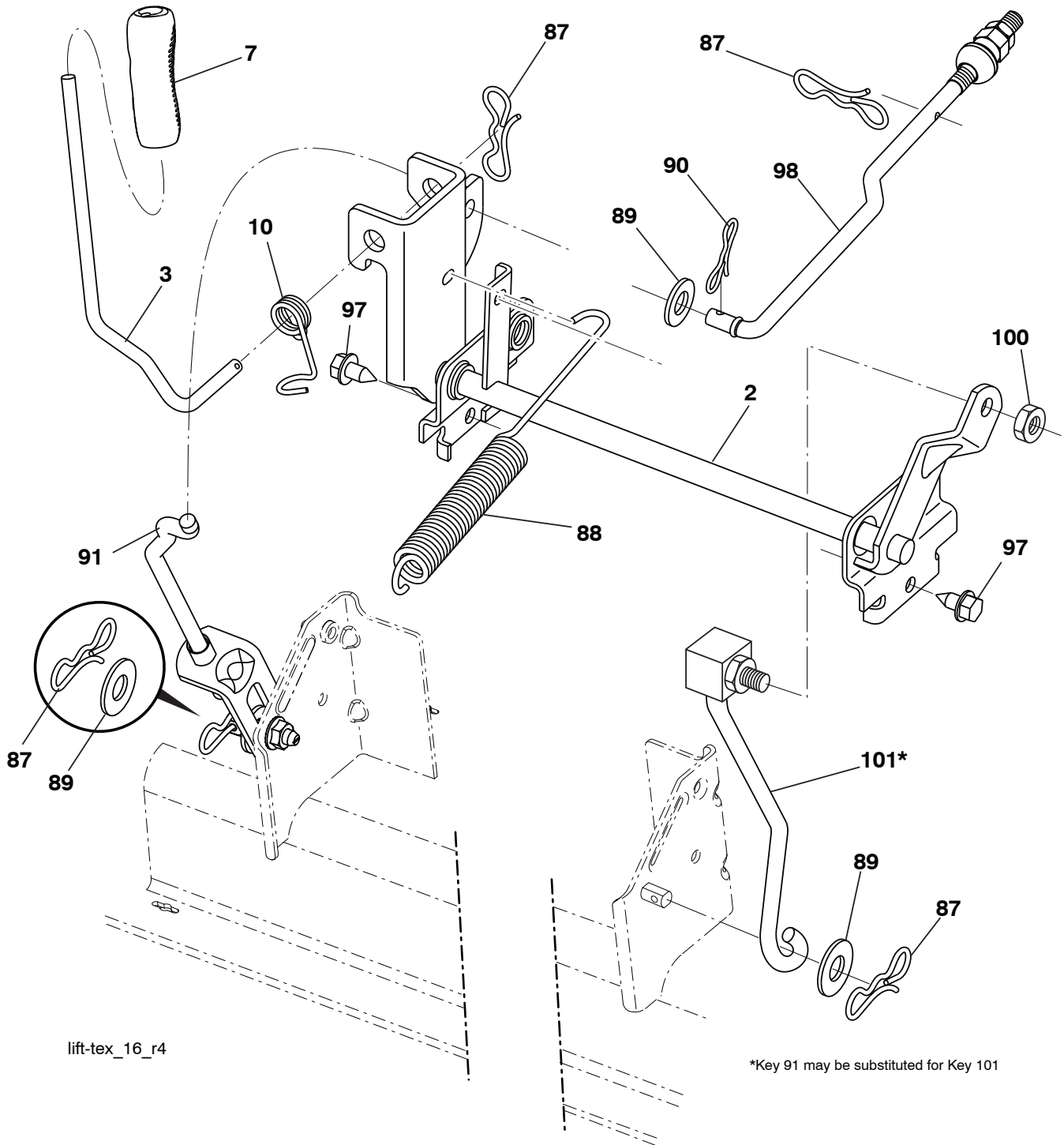

lift-tex\_16\_r4

\*Key 91 may be substituted for Key 101

KEY NO.	PART NO.	DESCRIPTION
2	532 42 20-27	Shaft Asm., Lift
3	532 19 52-31	Lever Asm., Lift RH
7	532 41 15-55	Grip, Lever
10	532 19 63-14	Spring Torsion
87	532 19 42-09	Pin Cotter 7/16 Bow Tie Lock
88	532 41 07-10	Spring Lift Assist
89	819 19 19-12	Washer Clear Zinc
90	532 19 42-08	Pin Cotter 5/16 Bow Tie Lock
91	532 19 51-81	Link Lift Susp Mower Rear

KEY NO.	PART NO.	DESCRIPTION
97	817 00 06-12	Screw 3/8-16 x .75
98	532 19 52-70	Link Lift Susp. Front Mower
100	873 93 06-00	Nut Center Lock 3/8-16 unc
101	532 40 70-03	Link Asm. Lift FXD

**NOTE:** All component dimensions given in U.S. inches  
1 inch = 25.4 mm



**TRACTOR - - MODEL NUMBER 917.289542, PRODUCT NO. YTH20K46  
TUFFTORQ TRANSAXLE MODEL NUMBER K46BT**

**MODEL K46BT  
7A646084180**

ACTUAL PARTS  
MAY NOT APPEAR  
AS SHOWN

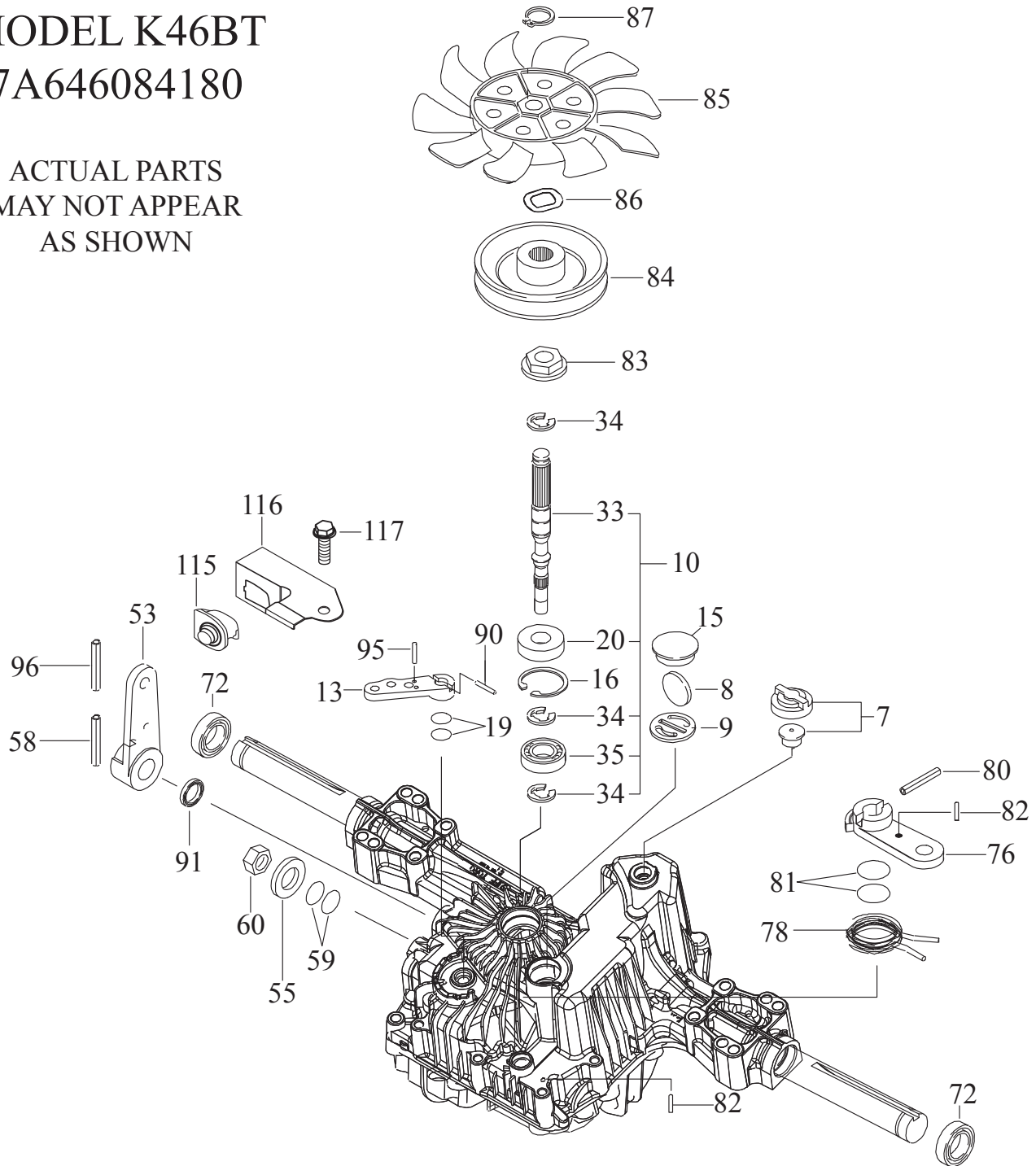

**TRACTOR - - MODEL NUMBER 917.289542, PRODUCT NO. YTH20K46  
TUFFTORQ TRANSAXLE MODEL NUMBER K46BT**

<b>KEY NO.</b>	<b>PART NO.</b>	<b>DESCRIPTION</b>
7	414395	Vent Valve 15
8	414396	Magnet
9	414397	Magnet Holder
10	415923	Pump Shaft/Bearing Kit
13	414398	Bypass Lever
15	414399	Sealing Cap 30
16	414400	Snap Ring C 35
19	414401	O-Ring 1a P10a
20	414402	Seal Tc 153507
33	414403	Pump Shaft (Standard)
34	414404	E-Ring 15
35	414405	Bearing 6202c3
53	414431	Control Lever F
55	415924	Washer 12
58	415925	Roll Pin 6 * 40
59	415926	O-Ring 1a P14
60	415927	Nut 12
72	414407	Seal 19 * 32 * 8
76	414408	Brake Lever
78	414409	Brake Return Spring
80	414410	Spring Pln 5 * 32
81	414411	O-Ring 1a P12
82	414412	Spring Pin 4 * 16
83	414413	Spine Collar
84	414414	Pulley L
85	414415	Fan, Black
86	414416	Wave Washer
87	414417	Snap Ring
90	414418	Spring Pin 3.0a * 20
91	414419	Oil Seal 16 * 22 * .03
95	414850	Spring Pin 3.0a*16
96	414420	Roll Pin 3.5 * 40
115	415928	Switch 6440-11 Delta
116	415929	Switch Bracket
117	415930	Tapping Screw 8 * 20

**NOTE:** All component dimensions given in U.S. inches  
1 inch = 25.4 mm

**TRACTOR - - MODEL NUMBER 917.289542, PRODUCT NO. YTH20K46**  
**KOHL ENGINE - MODEL NO. SV600-0212**

**HEAD/VALVE/BREATHER**

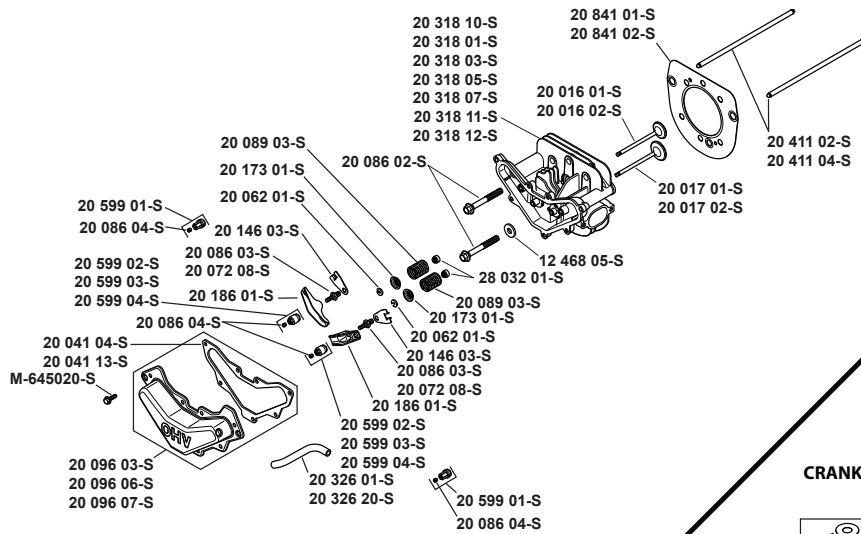

**CRANKCASE**

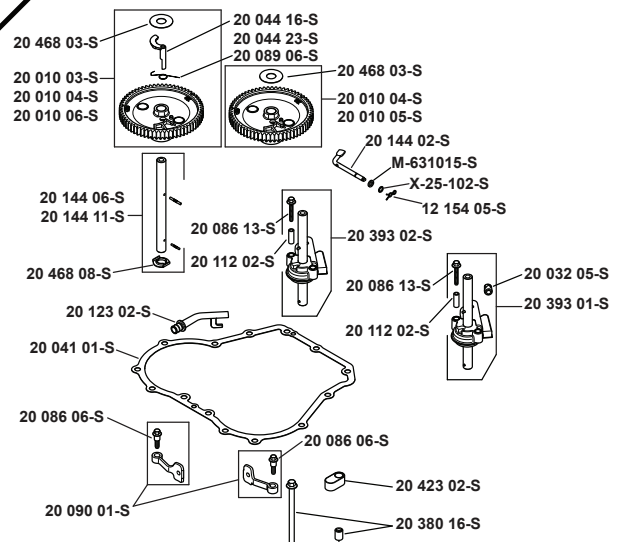

**CRANKSHAFT**

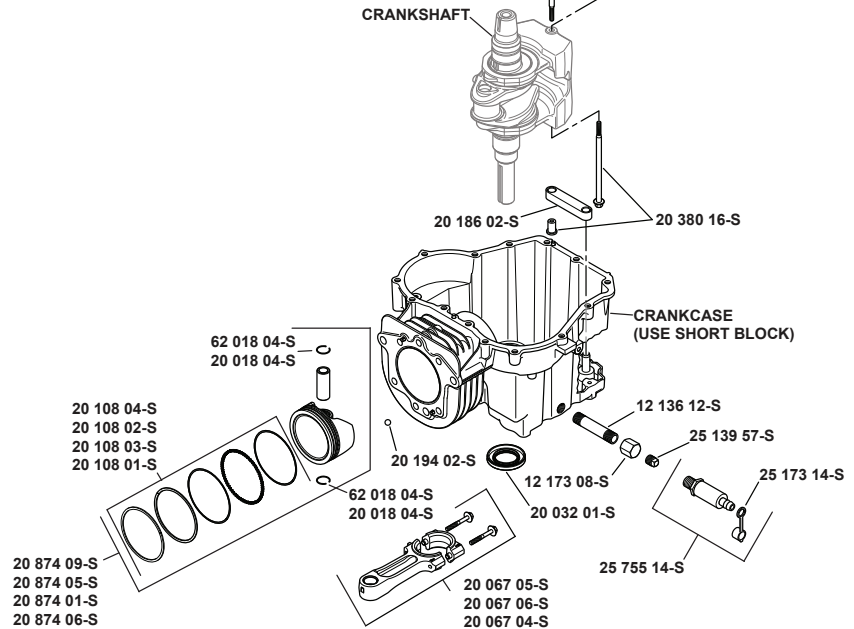

**ACCESSORIES**

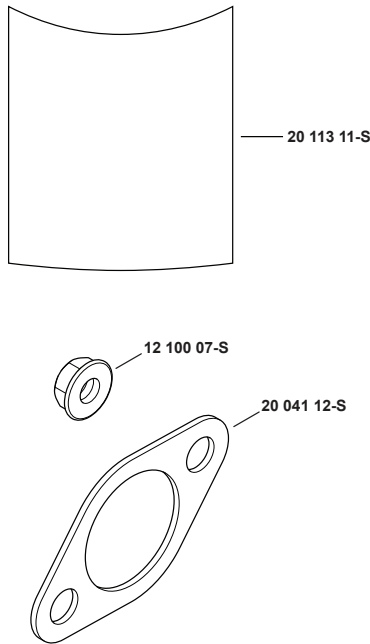

# TRACTOR - - MODEL NUMBER 917.289542, PRODUCT NO. YTH20K46

## KOHL ENGINE - MODEL NO. SV600-0212

### DECALS

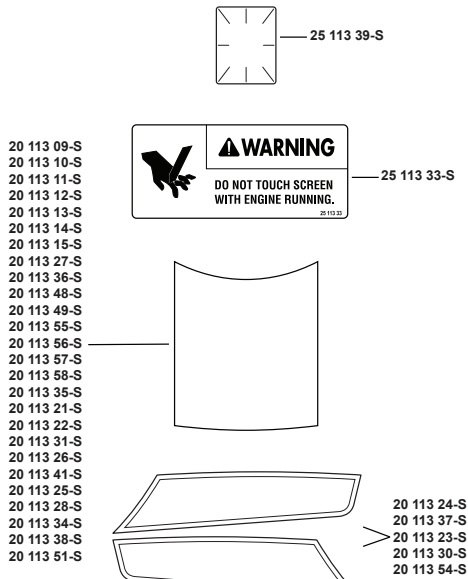

Artwork is representative.  
Actual labels may differ depending on model and specification number.

### BLOWER HOUSING & BAFFLES

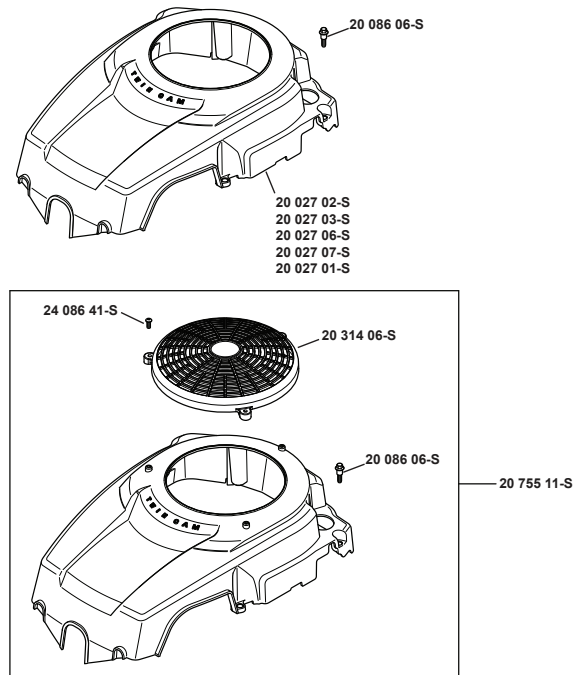

### IGNITION/ELECTRICAL

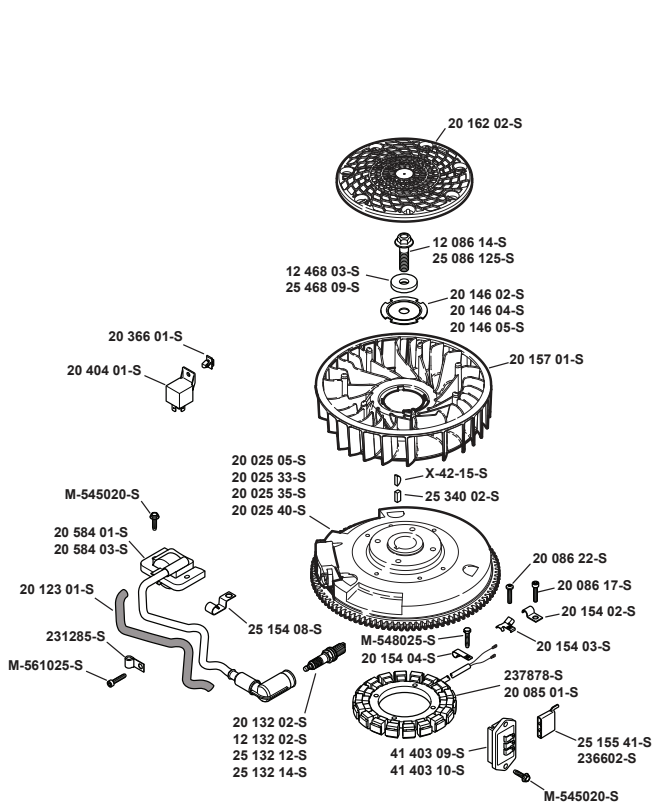

### CRANKSHAFT

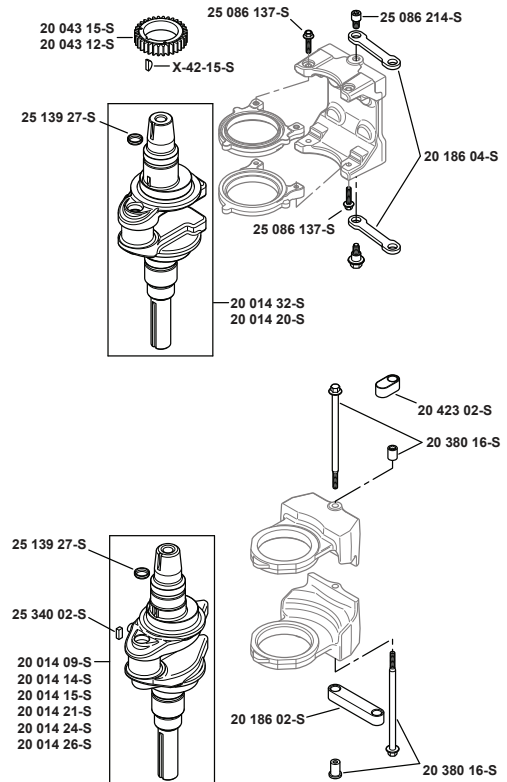

**TRACTOR - - MODEL NUMBER 917.289542, PRODUCT NO. YTH20K46**  
**KOHL ENGINE - MODEL NO. SV600-0212**

**AIR INTAKE/FILTRATION**

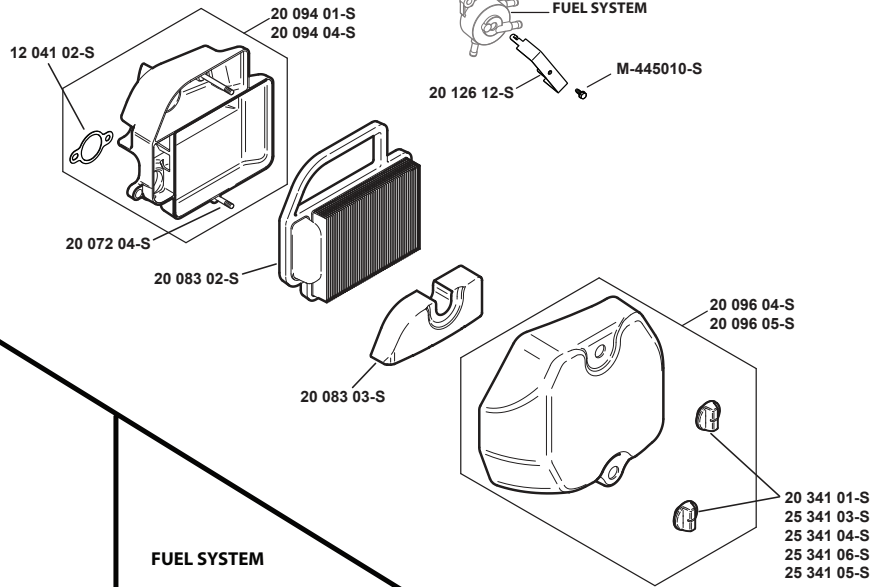

**STARTING SYSTEM**

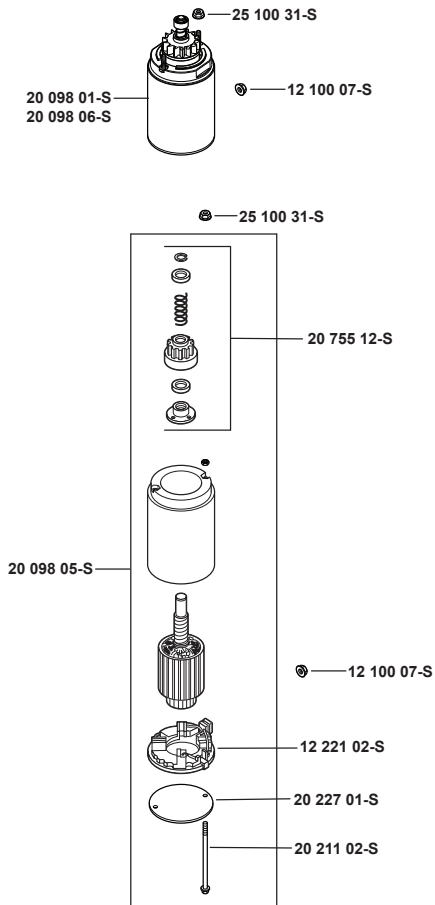

**FUEL SYSTEM**

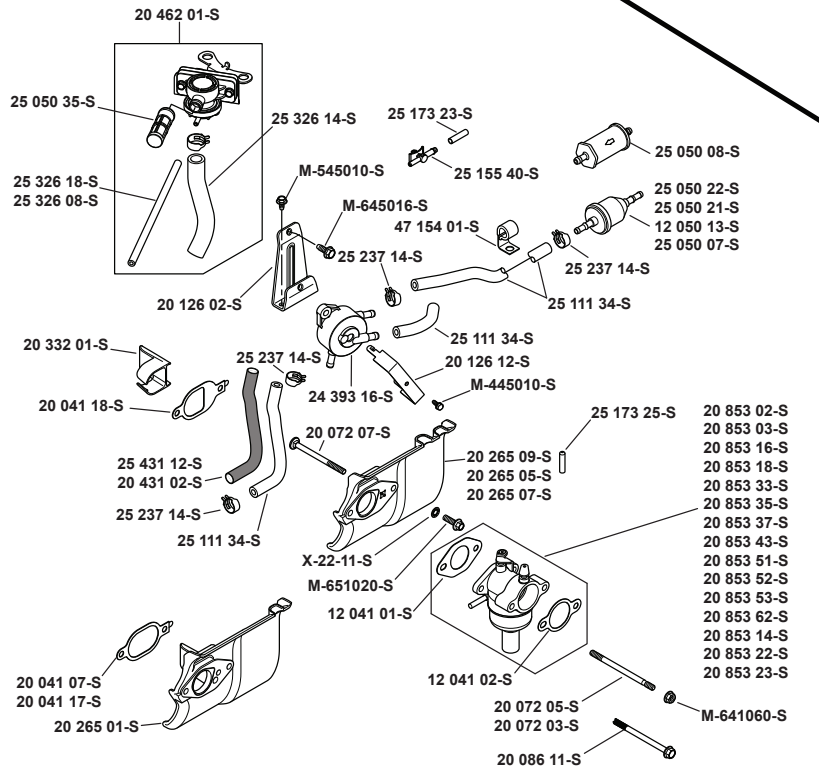

Individual Carburetor Repair Kits are listed by clicking on the notepad under the Carburetor Part Number

**TRACTOR - - MODEL NUMBER 917.289542, PRODUCT NO. YTH20K46**  
**KOHL ENGINE - MODEL NO. SV600-0212**

**ENGINE CONTROLS**

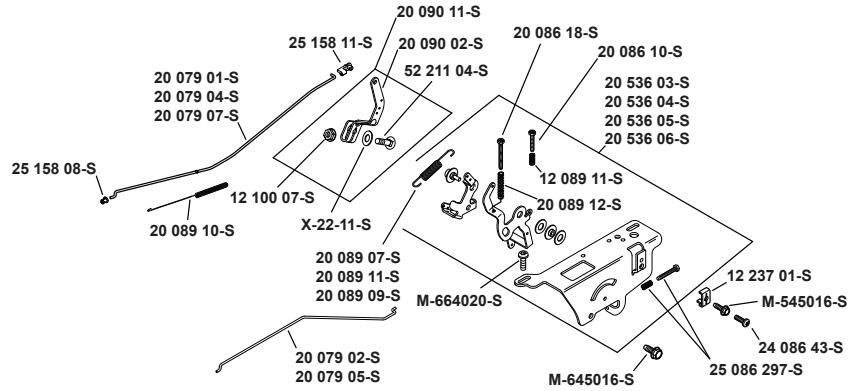

**OIL PAN/LUBRICATION**

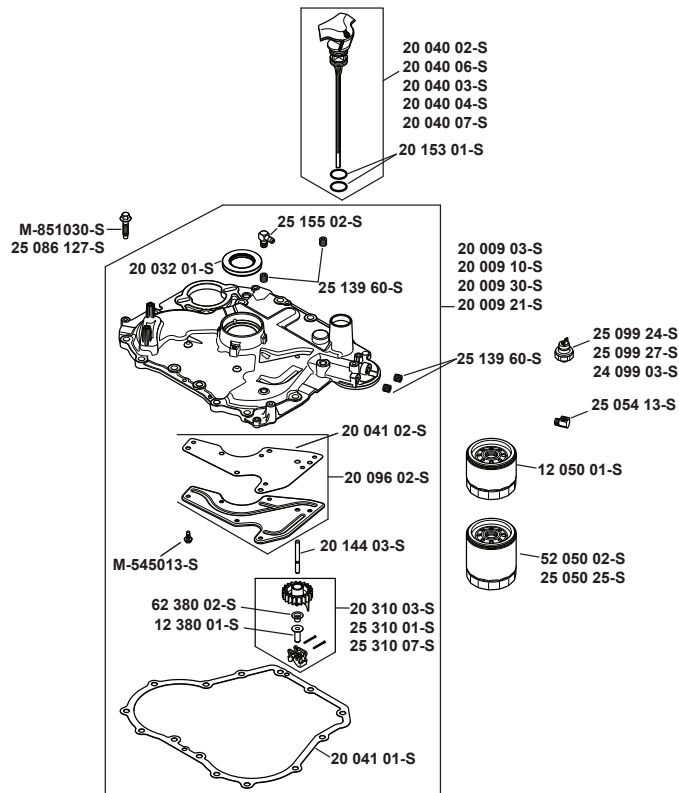

**TRACTOR - - MODEL NUMBER 917.289542, PRODUCT NO. YTH20K46**  
**KOHL ENGINE - MODEL NO. SV600-0212**

<b>PART NO.</b>	<b>DESCRIPTION</b>
<b>OIL PAN/LUBRICATION 3-20-28</b>	
20 040 06-S 1	Dipstick Assembly-std Yellow (Includes 20 153 01-S)
20 153 01-S 2	O-Ring
20 009 30-S 1	Closure Plate Assembly(Includes 25 139 60-S, 20 096 02-S, 20 041 02-S, 20 144 03-S, 25 310 07-S, 12 380 01- S, 20 041 01-S, M-545013-S, 20 032 01-S, 25 155 02-S)
25 139 60-S 4	Plug, Ctsk Pipe 1/8"
20 096 02-S 1	Kit, Oil Passage Cover (Includes 20 041 02-S)
20 041 02-S 1	Gasket, Oil Passage
20 144 03-S 1	Shaft, Governor Cross
25 310 07-S 1	Governor Gear Assembly (Includes 12 380 01-S, 62 380 02-S)
12 380 01-S 1	Pin, Governor Regulating
20 041 01-S 1	Gasket, Closure Plate
M-545013-S 6	Screw, Flg Thd Frm M5x0.8x13
20 032 01-S 1	Seal, Oil
25 155 02-S 1	Connector, 90° Hose
25 086 127-S 14	Hex Flange Screw,1/2 Dog Point
52 050 02-S 1	Filter, Oil
<b>HEAD/VALVE/BREATHER 4-20-1</b>	
20 096 07-S 1	Kit, Valve Cover (Includes 20 041 13-S)
20 041 13-S 1	Gasket, Valve Cover
M-645020-S 7	Screw, Flg Thd Frm M6x1.0x20
20 326 20-S 1	Hose, Breather
20 599 04-S 2	Rocker Pivot Assembly (Includes 20 086 04-S)
20 086 04-S 2	Screw, Set
20 186 01-S 2	Arm, Rocker
20 072 08-S 2	Stud, Rocker
20 146 03-S 2	Plate, Push Rod Guide
20 062 01-S 2	Lock, Retainer
20 173 01-S 2	Cap, Valve Spring
20 089 03-S 2	Spring, Valve
12 468 05-S 1	Washer, Flat 13/32"
20 086 02-S 6	Screw, Flg M10x1.5x80
20 016 01-S 1	Valve, Exhaust
20 017 01-S 1	Valve, Exhaust
20 841 01-S 1	Kit, Cylinder Head Gasket(Includes 12 041 01-S, 12 041 02-S, 12 468 05-S, 20 041 12-S, 20 041 13-S, 20 041 17- S, 20 041 18-S, 20 086 02-S, 25 086 87-S & X-21-1-S)
20 411 04-S 2	Rod, Push
20 318 11-S 1	Kit, Cylinder Head (Includes 25 086 87-S & X-21-1-S)
20 599 03-S 2	Kit Pivot, Rocker Arm (Includes 20 086 04-S)
<b>NOT ILLUSTRATED</b>	
12 041 01-S 1	Gasket, Carburetor
12 041 02-S 1	Gasket, Air Cleaner Base
20 041 12-S 1	Gasket, Exhaust
20 041 18-S 1	Gasket, Heat Deflector
20 041 17-S 1	Gasket, Heat Deflector
25 086 87-S 2	Screw, Hex Socket Head Cap
X-21-1-S 2	Washer, Spring Lock 5/16"

<b>PART NO.</b>	<b>DESCRIPTION</b>
<b>CRANKSHAFT 1-20-4</b>	
20 014 32-S 1	Kit, Crankshaft Assembly (Includes 25 139 27-S)
25 139 27-S 1	Plug, Cup
X-42-15-S 1	Key, 3/16" X 5/8"
20 043 15-S 1	Gear, Crankshaft
25 086 137-S 4	Screw, Flg M6x1.0x25
25 086 214-S 1	Screw, Link Pivot
20 186 04-S 2	Linkage, Balance Weight
25 086 213-S 1	Screw, Shoulder
<b>CRANKCASE 2-20-16</b>	
	1 Crankcase (Use Short Block)
20 032 01-S 1	Seal, Oil
20 067 05-S 1	Rod, Connecting Assembly
20 874 09-S 1	Kit, Piston W/Ring Set (94mm) (Includes 20 108 04-S, 62 018 04-S)
20 108 04-S 1	Ring Set (94mm)
62 018 04-S 2	Retainer, Piston Pin
20 090 01-S 2	Kit, Cam Lever Assembly (Includes 20 086 06-S)
20 086 06-S 2	Screw, Shd Thd Frm M6x1x26
20 041 01-S 1	Gasket, Closure Plate
20 123 02-S 1	Tube, Drainback
12 154 05-S 1	Clip, Hitch Pin
M-631015-S 1	Washer, Flat 6 Mm
X-25-102-S 1	Washer, Flat 1/4"
20 144 02-S 1	Shaft, Governor Cross
20 393 02-S 1	Kit, Oil Pump Assembly (Includes 20 041 01-S, 20 112 02-S, 20 086 13-S)
20 112 02-S 2	Spacer, Oil Pump Screw
20 086 13-S 2	Screw, Oil Pump
20 144 11-S 1	Kit,Cam Center Shaft (Exhaust) (Includes 20 468 08-S)
20 468 08-S 1	Washer, Thrust
20 010 04-S 1	Kit, Camshaft Assembly (Includes 20 089 06-S, 20 044 23-S, 20 468 03-S)
20 089 06-S 1	Spring, Acr
20 468 03-S 1	Washer, Thrust -Acr
20 010 04-S 1	Kit, Camshaft Assembly (Includes 20 468 03-S)
20 468 03-S 1	Washer, Thrust -Acr
25 139 57-S 1	Plug, Sq Hd Pipe 3/8"
20 044 16-S 1	Use 20 044 23-S Acr Weight

**TRACTOR - - MODEL NUMBER 917.289542, PRODUCT NO. YTH20K46  
KOHL ENGINE - MODEL NO. SV600-0212**

**PART NO. DESCRIPTION**

**IGNITION/ELECTRICAL 5-20-1**

20 162 02-S	1	Screen, Grass
25 086 125-S	1	Screw, Hex Flange
25 468 09-S	1	Washer, Flat
20 146 05-S	1	Plate, Fan Mounting
20 157 01-S	1	Fan
25 340 02-S	1	Key, Straight Flywheel
20 025 40-S	1	Flywheel
M-548025-S	2	Screw, Thd Frm M5x0.8x25
20 154 04-S	1	Clip, Wire
237878-S	1	Kit, 15 Amp Stator (Includes 25 452 01-S)
25 155 41-S	1	Connector
M-545020-S	2	Screw, Flg Thd Frm M5x.8x20
41 403 10-S	1	Regulator/Rectifier
20 584 03-S	1	Module, Ignition (Cdi Fixed)
M-545020-S	2	Screw, Flg Thd Frm M5x.8x20
12 132 02-S	1	Plug, Spark (Std)

**NOT ILLUSTRATED**

20 176 13-S	1	Harness, Wiring
25 452 01-S	2	Terminal
25 454 05-S	1	Tie

**BLOWER HOUSING & BAFFLES 6-20-5**

20 027 07-S	1	Kit, Blower Housing (Includes 41 037 10-S)
20 086 06-S	4	Screw, Shd Thd Frm M6x1x26

**Not Illustrated**

41 037 10-S	1	Nameplate, Service
-------------	---	--------------------

**STARTING SYSTEM 7-20-1**

20 098 05-S	1	Starter Assembly (Service With 12 221 02-S, 20 755 12-S, 20 227 01-S, 20 211 02-S)
25 100 31-S	2	Nut, Free Spinning Flg #10-24
12 221 02-S	1	Brush Kit
20 755 12-S	1	Kit, Drive (J.E.)
20 227 01-S	1	Cap, Drive End (J.E.)
20 211 02-S	1	Bolt, Thru

**FUEL GROUP 8-20-40**

25 237 14-S	4	Clamp, Hose 1/2"
25 111 34-S	2	Line, Fuel (24"-Cut To Length)
20 265 09-S	1	Kit, Heat Deflector (Includes 12 041 02-S, 20 041 18-S, 20 072 07-S, 20 332 01-S)
X-22-11-S	1	Washer, Int Tooth Lock 1/4"
M-651020-S	1	Screw, Flg M6x1.0x20
20 853 35-S	1	Kit, Carburetor (Includes 12 041 01- S, 12 041 02-S) (S/W 12 755 109-S, 12 755 110-S, 12 757 02-S, 12 757 03-S, 12 757 33-S, 12 757 37-S, 20 755 07-S)
12 041 01-S	1	Gasket, Carburetor
12 041 02-S	1	Gasket, Air Cleaner Base
20 072 05-S	1	Stud, M6x1.0x100
M-641060-S	2	Nut, Flg M6x1.0
20 072 07-S	1	Stud, Carburetor
20 041 18-S	1	Gasket, Heat Deflector
20 332 01-S	1	Insert, Intake Port
25 050 21-S	1	Filter, Fuel

**PART NO. DESCRIPTION**

**NOT ILLUSTRATED**

25 454 05-S	1	Tie
12 755 109-S	1	Kit, High Alt(5000 Or 10000 Ft)
12 755 110-S	1	Kit, Repair Choke
12 757 02-S	1	Kit, Repair Float
12 757 03-S	1	Kit, Repair Carburetor
12 757 33-S	1	Kit, Repair Solenoid
12 757 37-S	1	Kit, Repair Bowl Replacement
20 755 07-S	1	Kit, High Altitude (10,000 Ft)

**ENGINE CONTROLS 9-20-8**

20 536 06-S	1	Kit, Speed Control Assembly (In- cludes 25 086 297-S, 20 089 12-S, M- 66420-S [Qty.1], 20 089 11-S, 20 086 18-S, 20 086 10-S, 12 089 11-S)
25 086 297-S	1	Kit, Idle Adj Screw & Spring
20 089 12-S	1	Spring, Speed Control (Long)
12 237 01-S	2	Clamp, Cable
M-664020-S	2	Screw, Lbd Skt M6x1.0x20
20 090 11-S	1	Lever, Governor Assembly (Includes 9-11)
52 211 04-S	1	Bolt, Rd Hd Sq Nck 1/4-20x1"
X-22-11-S	1	Washer, Int Tooth Lock 1/4"
12 100 07-S	1	Nut, Hex Flg 1/4-20"
25 158 11-S	1	Bushing, Throttle Linkage
20 079 07-S	1	Linkage, Throttle
25 158 08-S	1	Bushing, Linkage Retaining
20 089 10-S	1	Spring, Linkage
20 079 05-S	1	Linkage, Choke
20 086 18-S	1	Screw, Phl Thd Frm M4x0.7x38
24 086 43-S	1	Screw, Lbd Thd Frm M5x0.8x16
20 086 10-S	1	Screw, Phl Thd Frm M4x0.7x25
12 089 11-S	1	Spring, Speed Control (Short)

**AIR INTAKE/FILTRATION 10-20-9**

20 096 04-S	1	Kit, Air Cleaner Cover (Includes 25 341 04-S)
25 341 04-S	2	Knob, Cover
20 083 02-S	1	Element, Air Cleaner
20 094 04-S	1	Kit, Air Cleaner Base (Includes 12 041 02-S, 20 072 04-S)
20 072 04-S	2	Stud, Air Cleaner Base
12 041 02-S	1	Gasket, Air Cleaner Base

**DECALS 12-20-23**

20 113 36-S	1	Decal, 20hp
20 113 37-S	1	Decal, Wing Set
25 113 39-S	1	Decal, Clear Laminate

**ACCESSORIES FOR SV600-0212**

20 041 12-S	1	Gasket, Exhaust
-------------	---	-----------------



---

# SERVICE NOTES

---

# SUGGESTED GUIDE FOR SIGHTING SLOPES FOR SAFE OPERATION

