

ILLUSTRATED PARTS LIST

MODEL NUMBER 16530 EXL

PRODUCT NUMBER 961 93 00-69

MFG. ID. NUMBER 96193006901

REPAIR PARTS

AUGER HOUSING / IMPELLER ASSEMBLY

SNOW THROWER - MODEL NO. 16530 EXL (96193006901), PRODUCT NO. 961 93 00-69

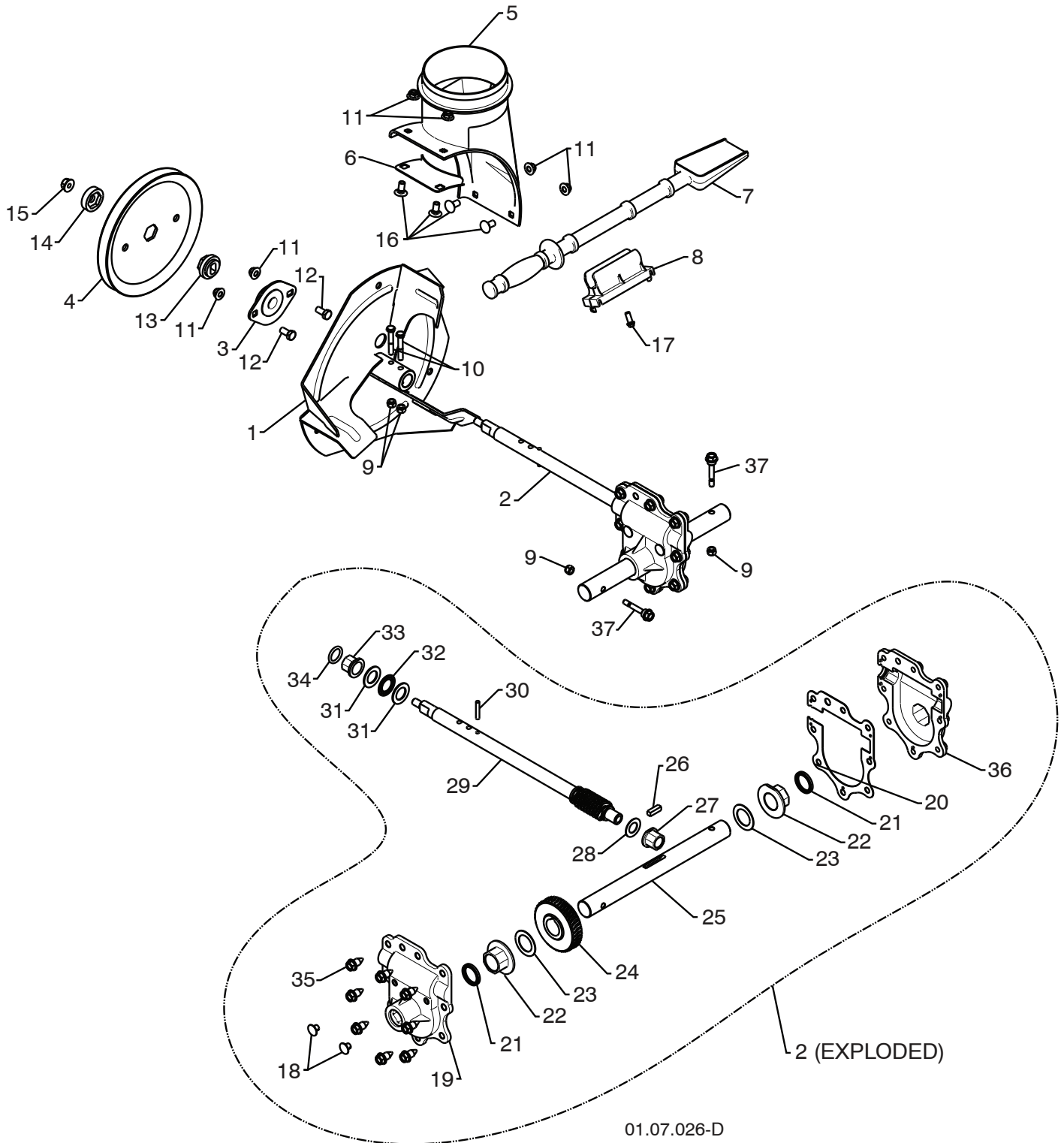

NOTE: All component dimensions given in U.S. inches. 1 inch = 25.4 mm
IMPORTANT: Use only Original Equipment Manufacturer (O.E.M.) replacement parts.
Failure to do so could be hazardous, damage your snow thrower and void your warranty.

REPAIR PARTS

AUGER HOUSING / IMPELLER ASSEMBLY

SNOW THROWER - MODEL NO. **16530 EXL** (96193006901), PRODUCT NO. 961 93 00-69

KEY NO.	PART NO.	DESCRIPTION
1	532 43 57-75	IMPELLER
2	532 42 71-48	GEARBOX ASSEMBLY
3	532 18 89-09	BEARING
4	532 42 71-46	IMPELLER PULLEY
5	532 17 53-22	DISCHARGE BASE
6	532 43 62-36	CORNER BRACKET
7	532 19 21-99	CLEAN OUT TOOL
8	532 40 54-00	TOOL CLIP
9	873 80 04-00	NUT 1/4-20
10	874 78 04-26	SCREW 1/4-20 X .625
11	532 42 79-42	NUT 5/16-18
12	532 16 31-83	SCREW 5/16-18 X .625
13	532 42 71-45	IMPELLER HUB
14	532 42 71-54	IMPELLER SLEEVE
15	873 90 06-00	NUT 3/8-16
16	532 18 03-55	CARRIAGE BOLT
17	532 19 41-89	SCREW 13-16 X .625
18	532 40 77-60	PLUG
19	532 42 73-02	GEARBOX COVER RH
20	532 42 73-45	GASKET
21	532 40 77-70	SEAL
22	532 40 77-62	BEARING
23	532 17 46-97	THRUST WASHER 1.00
24	532 40 77-63	WORM GEAR
25	532 40 77-64	AUGER SHAFT
26	532 18 92-82	SQUARE KEY
27	532 40 77-58	BEARING
28	532 17 46-83	THRUST WASHER
29	532 42 71-47	IMPELLER SHAFT
30	532 18 42-05	ROLL PIN
31	532 17 46-81	THRUST WASHER
32	532 17 46-84	THRUST BEARING
33	532 40 77-69	BEARING
34	532 40 77-68	O-RING
35	532 40 77-67	SCREW 5/16-18 X .750
36	532 42 73-17	GEARBOX COVER LH
37	532 19 20-90	SHEAR BOLT

NOTE: All component dimensions given in U.S. inches. 1 inch = 25.4 mm

IMPORTANT: Use only Original Equipment Manufacturer (O.E.M.) replacement parts. Failure to do so could be hazardous, damage your snow thrower and void your warranty.

REPAIR PARTS

AUGER HOUSING / IMPELLER ASSEMBLY

SNOW THROWER - MODEL NO. 16530 EXL (96193006901), PRODUCT NO. 961 93 00-69

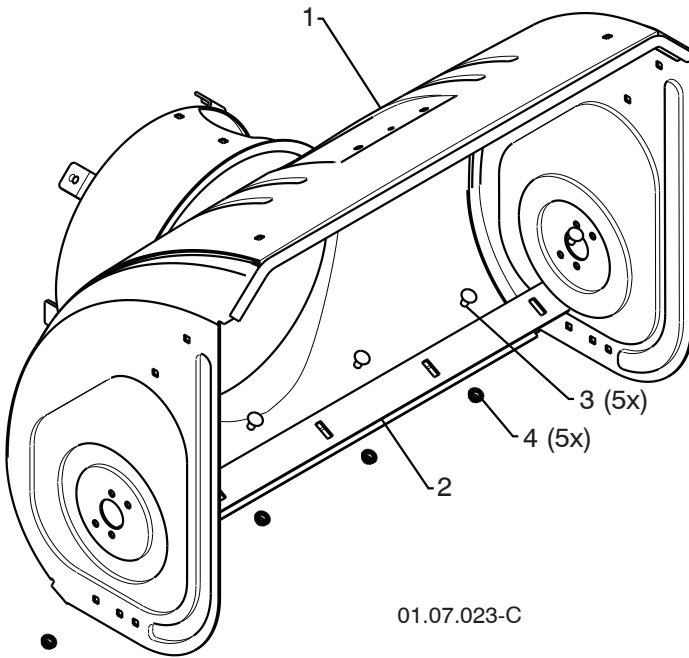

01.07.023-C

KEY NO.	PART NO.	DESCRIPTION
1	532 42 93-92	AUGER HOUSING
2	532 43 58-30	SCRAPER BAR
3	872 27 05-05	CARRIAGE BOLT 5/16-18 X .625
4	532 15 53-77	NUT 5/16-18

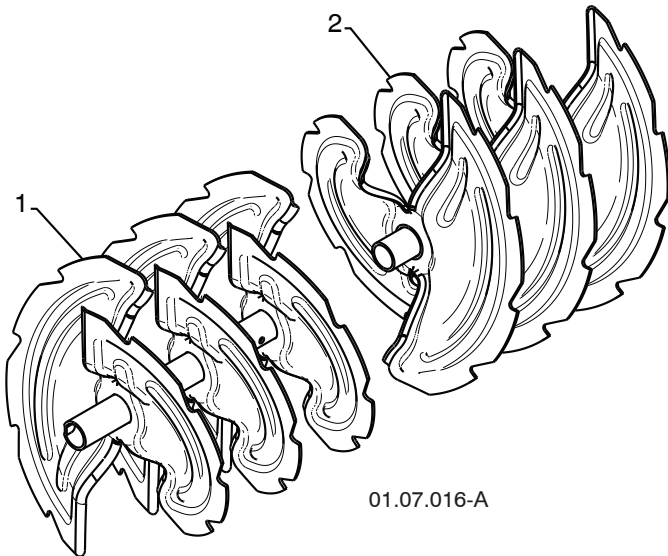

01.07.016-A

KEY NO.	PART NO.	DESCRIPTION
1	532 43 58-56	AUGER ASSEMBLY 30 LH
2	532 43 58-58	AUGER ASSEMBLY 30 RH

NOTE: All component dimensions given in U.S. inches. 1 inch = 25.4 mm
IMPORTANT: Use only Original Equipment Manufacturer (O.E.M.) replacement parts.
Failure to do so could be hazardous, damage your snow thrower and void your warranty.

REPAIR PARTS

AUGER HOUSING / IMPELLER ASSEMBLY

SNOW THROWER - MODEL NO. **16530 EXL** (96193006901), PRODUCT NO. 961 93 00-69

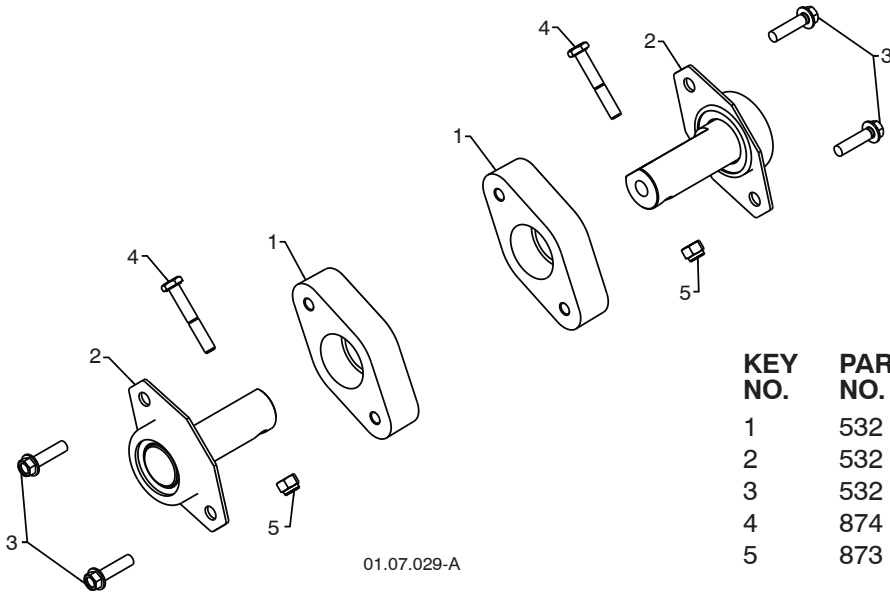

KEY NO.	PART NO.	DESCRIPTION
1	532 43 27-65	PLASTIC RETAINER
2	532 42 77-62	AUGER BALL BEARING
3	532 17 95-82	SCREW 5/16-18 X 1.00
4	874 78 04-26	SCREW 1/4-20 X .625
5	873 80 04-00	NUT 1/4-20

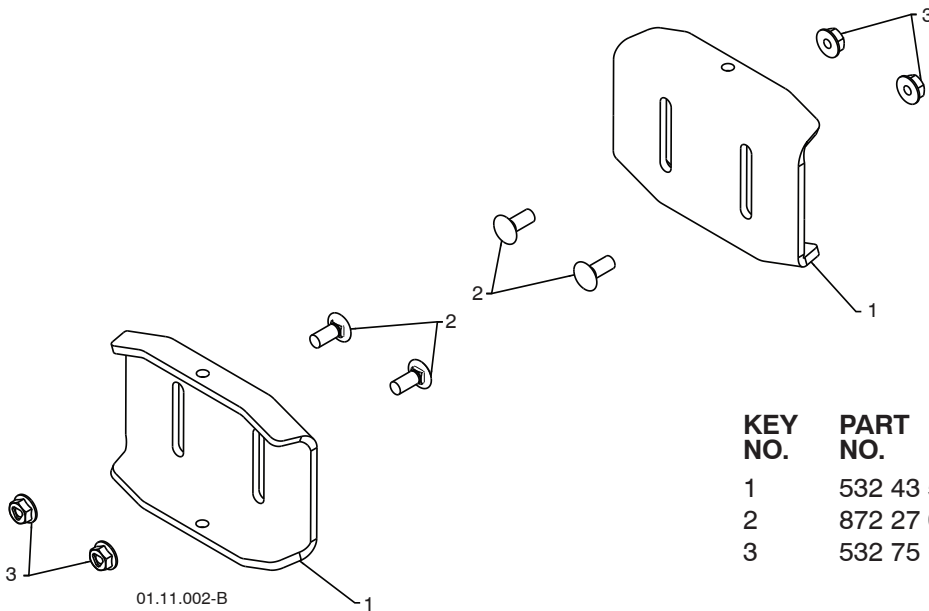

KEY NO.	PART NO.	DESCRIPTION
1	532 43 57-85	SKID PLATE
2	872 27 05-06	CARRIAGE BOLT 5/16-18 X .750
3	532 75 11-53	NUT 5/16-18

NOTE: All component dimensions given in U.S. inches. 1 inch = 25.4 mm
IMPORTANT: Use only Original Equipment Manufacturer (O.E.M.) replacement parts.
 Failure to do so could be hazardous, damage your snow thrower and void your warranty.

REPAIR PARTS

AUGER HOUSING / IMPELLER ASSEMBLY

SNOW THROWER - MODEL NO. 16530 EXL (96193006901), PRODUCT NO. 961 93 00-69

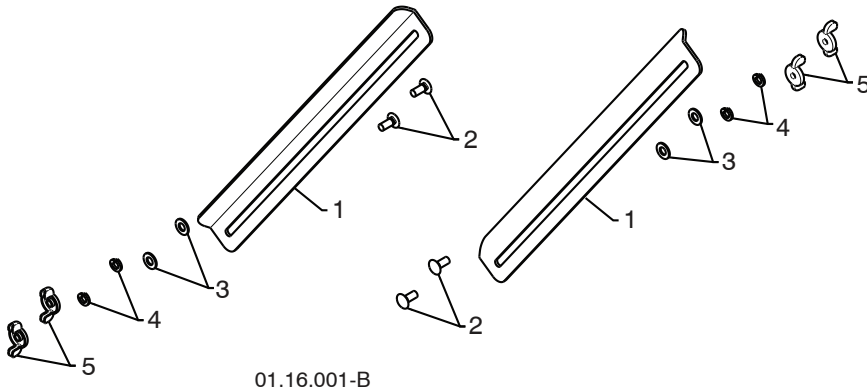

KEY NO.	PART NO.	DESCRIPTION
1	532 43 58-32	DRIFT CUTTER BAR
2	872 27 05-06	CARRIAGEBOLT 5/16-18X.750
3	532 17 92-46	PLASTIC WASHER
4	810 04 05-00	LOCKWASHER 5/16
5	532 12 86-38	NUT 5/16-18

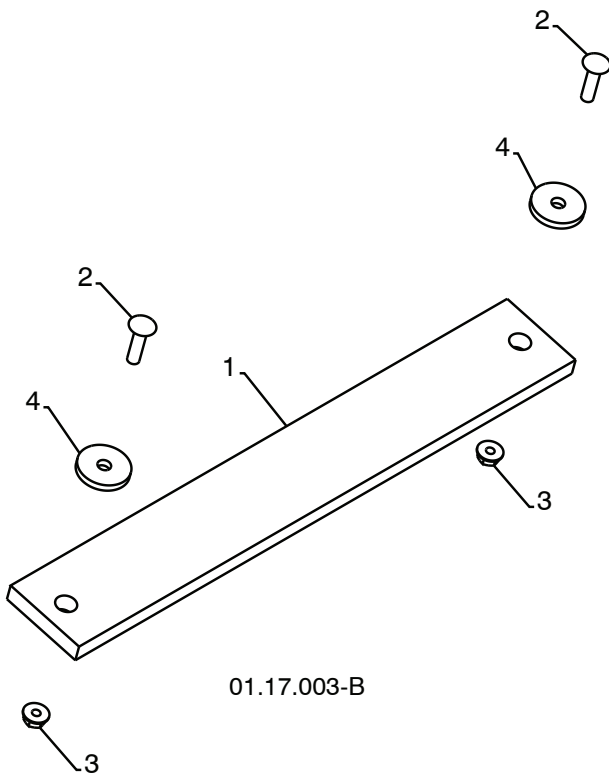

KEY NO.	PART NO.	DESCRIPTION
1	532 18 25-16	WEIGHT BAR
2	872 11 05-10	CARRIAGE BOLT 5/16-18 X 1.25
3	532 75 11-53	NUT 5/16-18
4	819 11 22-06	WASHER

NOTE: All component dimensions given in U.S. inches. 1 inch = 25.4 mm
IMPORTANT: Use only Original Equipment Manufacturer (O.E.M.) replacement parts.
 Failure to do so could be hazardous, damage your snow thrower and void your warranty.

REPAIR PARTS

CONTROL PANEL / DISCHARGE CHUTE

SNOW THROWER - MODEL NO. **16530 EXL** (96193006901), PRODUCT NO. 961 93 00-69

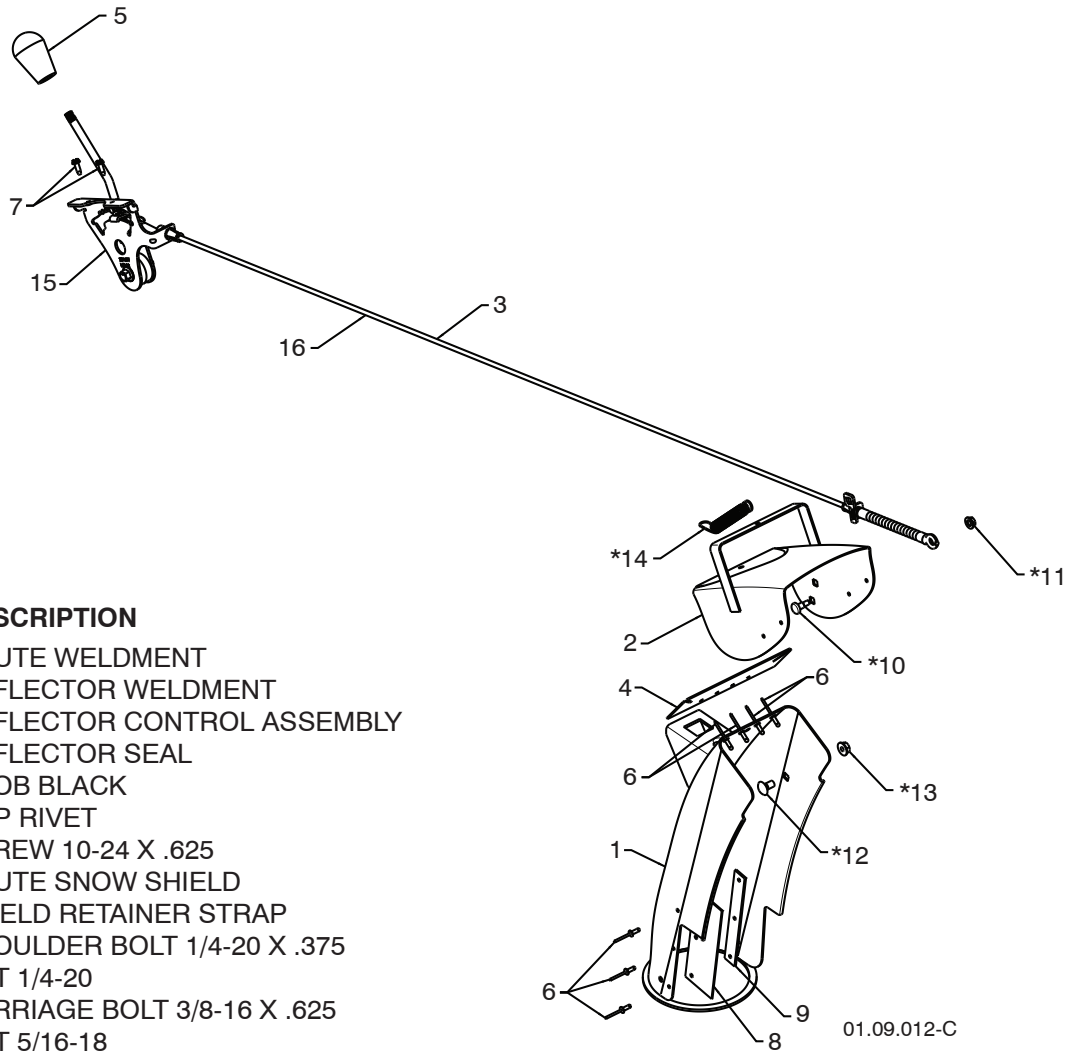

KEY NO.	PART NO.	DESCRIPTION
1	532 43 57-91	CHUTE WELDMENT
2	532 18 41-13	DEFLECTOR WELDMENT
3	532 42 11-63	DEFLECTOR CONTROL ASSEMBLY
4	532 42 03-25	DEFLECTOR SEAL
5	532 41 42-80	KNOB BLACK
6	532 12 84-15	POP RIVET
7	817 50 10-10	SCREW 10-24 X .625
8	532 43 03-24	CHUTE SNOW SHIELD
9	532 43 57-76	SHIELD RETAINER STRAP
*10	532 17 98-29	SHOULDER BOLT 1/4-20 X .375
*11	532 19 17-30	NUT 1/4-20
*12	872 25 05-05	CARRIAGE BOLT 3/8-16 X .625
*13	532 75 11-53	NUT 5/16-18
*14	532 18 45-05	DEFLECTOR SPRING
15	532 42 06-79	(SERVICE PART) DEFLECTOR CONTROL
16	532 42 11-64	(SERVICE PART) DEFLECTOR CABLE GRAY

NOTE:

1. ALL ITEMS INDICATED WITH AN * ARE PROVIDED IN THE BAG OF ITEMS SHIPPED LOOSE WITH PRODUCT.
2. ITEMS 15 AND 16 ARE SERVICE PART NUMBERS TO ALLOW PURCHASE OF INDIVIDUAL ITEMS IF NECESSARY.

01.09.012-C

NOTE: All component dimensions given in U.S. inches. 1 inch = 25.4 mm
IMPORTANT: Use only Original Equipment Manufacturer (O.E.M.) replacement parts.
 Failure to do so could be hazardous, damage your snow thrower and void your warranty.

REPAIR PARTS

CONTROL PANEL / DISCHARGE CHUTE

SNOW THROWER - MODEL NO. 16530 EXL (96193006901), PRODUCT NO. 961 93 00-69

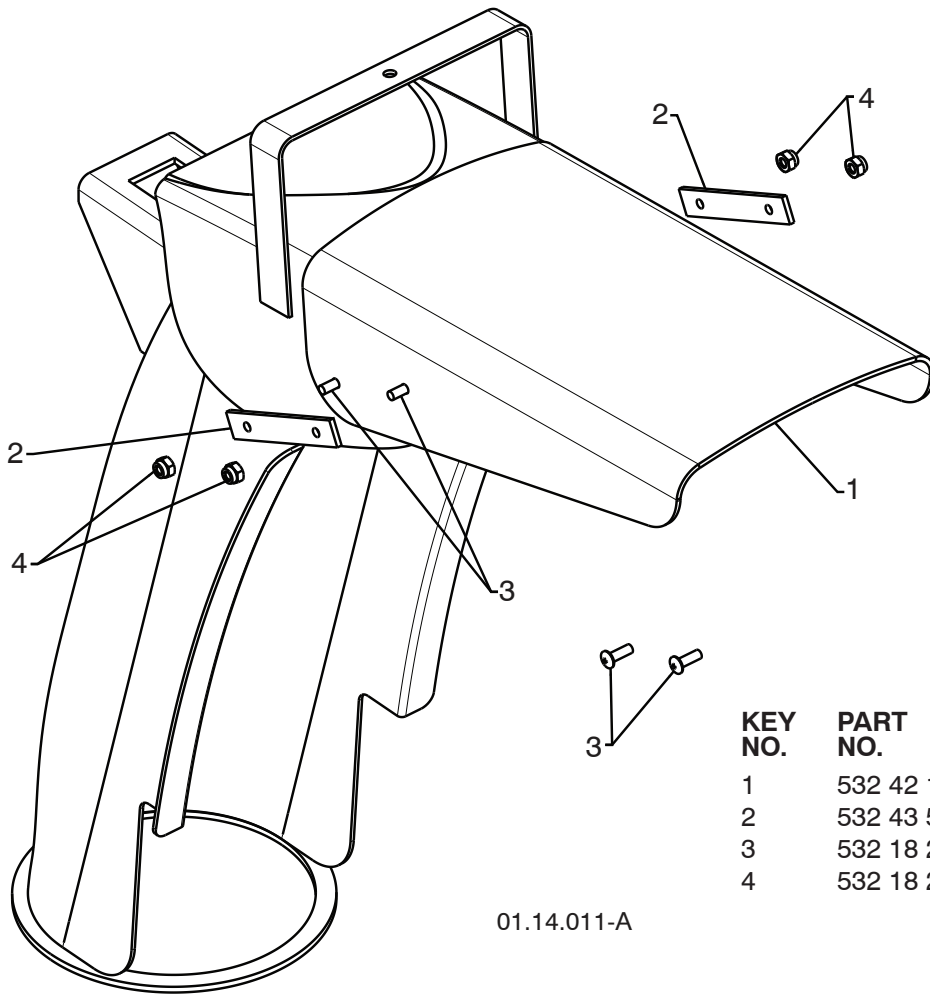

01.14.011-A

KEY NO.	PART NO.	DESCRIPTION
1	532 42 11-38	SHIELD DEFLECTOR
2	532 43 58-31	STRAP
3	532 18 22-27	SCREW 8-32 X .50
4	532 18 22-28	NUT 8-32

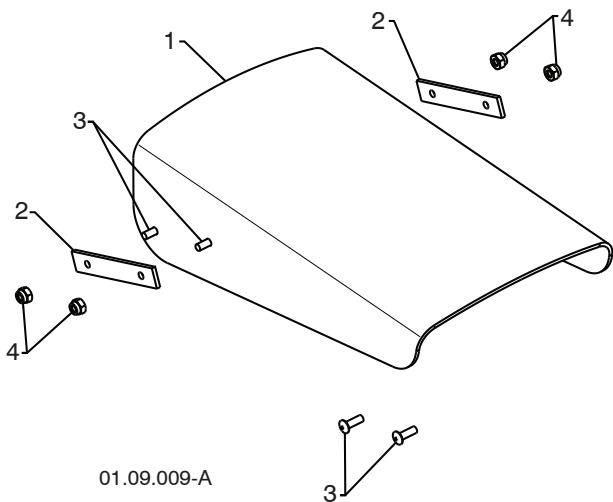

01.09.009-A

KEY NO.	PART NO.	DESCRIPTION
1	532 42 11-38	SHIELD DEFLECTOR
2	532 43 58-31	STRAP
3	532 18 22-27	SCREW 8-32 X .50
4	532 18 22-28	NUT 8-32

NOTE: All component dimensions given in U.S. inches. 1 inch = 25.4 mm
IMPORTANT: Use only Original Equipment Manufacturer (O.E.M.) replacement parts.
 Failure to do so could be hazardous, damage your snow thrower and void your warranty.

REPAIR PARTS

CONTROL PANEL / DISCHARGE CHUTE

SNOW THROWER - MODEL NO. **16530 EXL** (96193006901), PRODUCT NO. 961 93 00-69

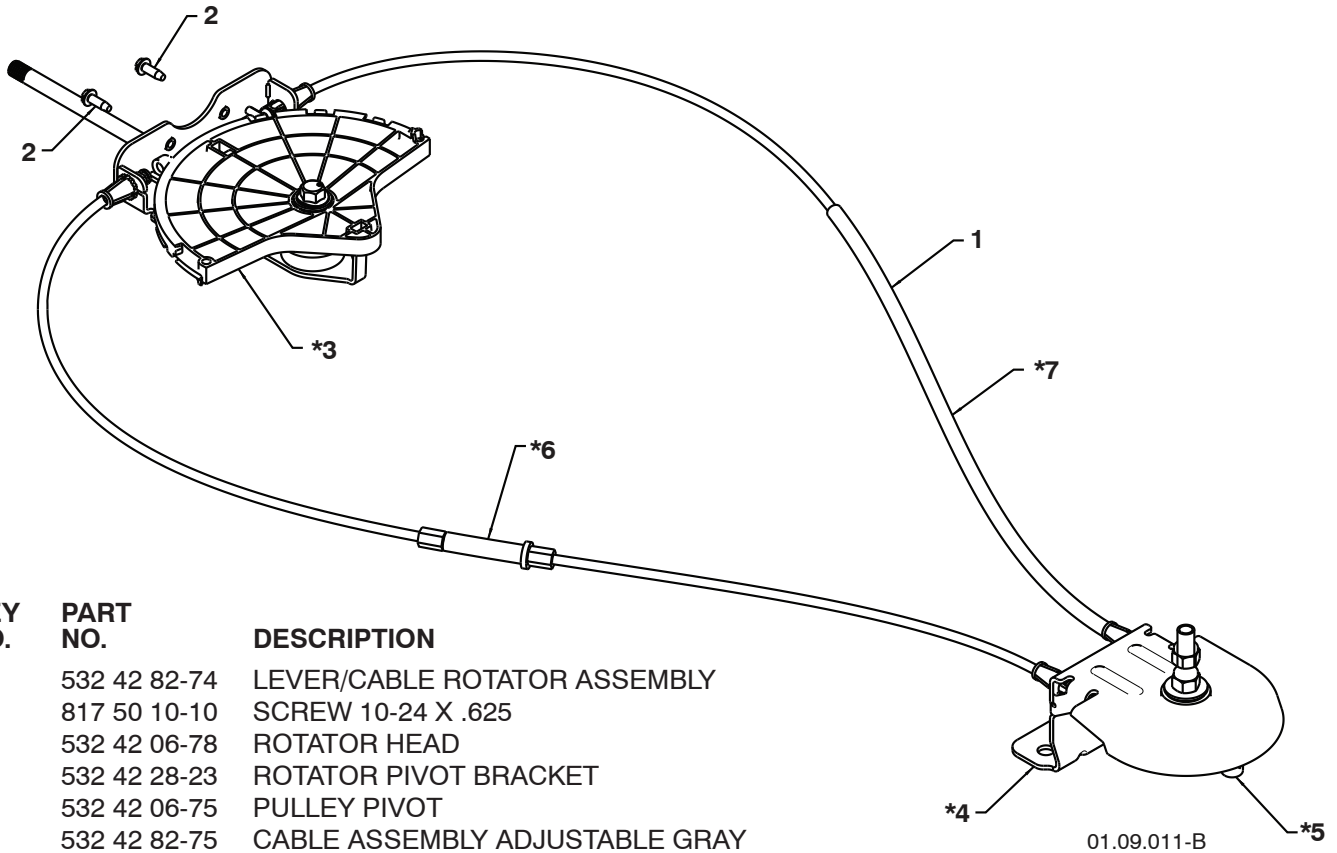

KEY NO.	PART NO.	DESCRIPTION
1	532 42 82-74	LEVER/CABLE ROTATOR ASSEMBLY
2	817 50 10-10	SCREW 10-24 X .625
*3	532 42 06-78	ROTATOR HEAD
*4	532 42 28-23	ROTATOR PIVOT BRACKET
*5	532 42 06-75	PULLEY PIVOT
*6	532 42 82-75	CABLE ASSEMBLY ADJUSTABLE GRAY
*7	532 42 83-11	CABLE ASSEMBLY HEAT SHIELD GRAY

NOTES:

1. ITEMS INDICATED WITH AN * ARE LISTED AS REFERENCE FOR SERVICE PARTS ONLY.

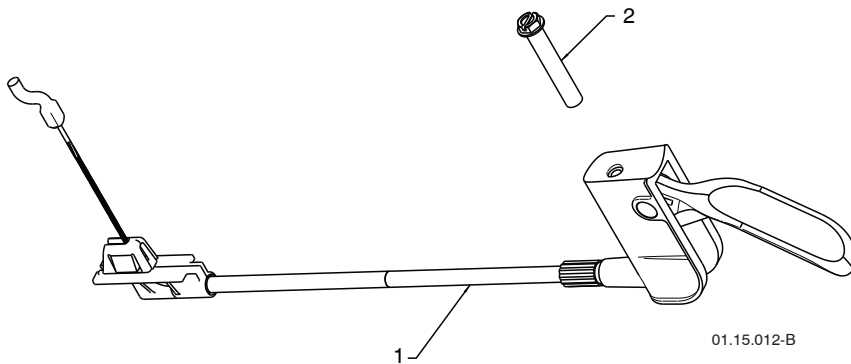

KEY NO.	PART NO.	DESCRIPTION
1	532 42 56-93	STEER CABLE
2	874 04 10-24	SCREW 10-24 X 1.50

NOTE: All component dimensions given in U.S. inches. 1 inch = 25.4 mm
IMPORTANT: Use only Original Equipment Manufacturer (O.E.M.) replacement parts.
 Failure to do so could be hazardous, damage your snow thrower and void your warranty.

REPAIR PARTS

HANDLES

SNOW THROWER - MODEL NO. **16530 EXL** (96193006901), PRODUCT NO. 961 93 00-69

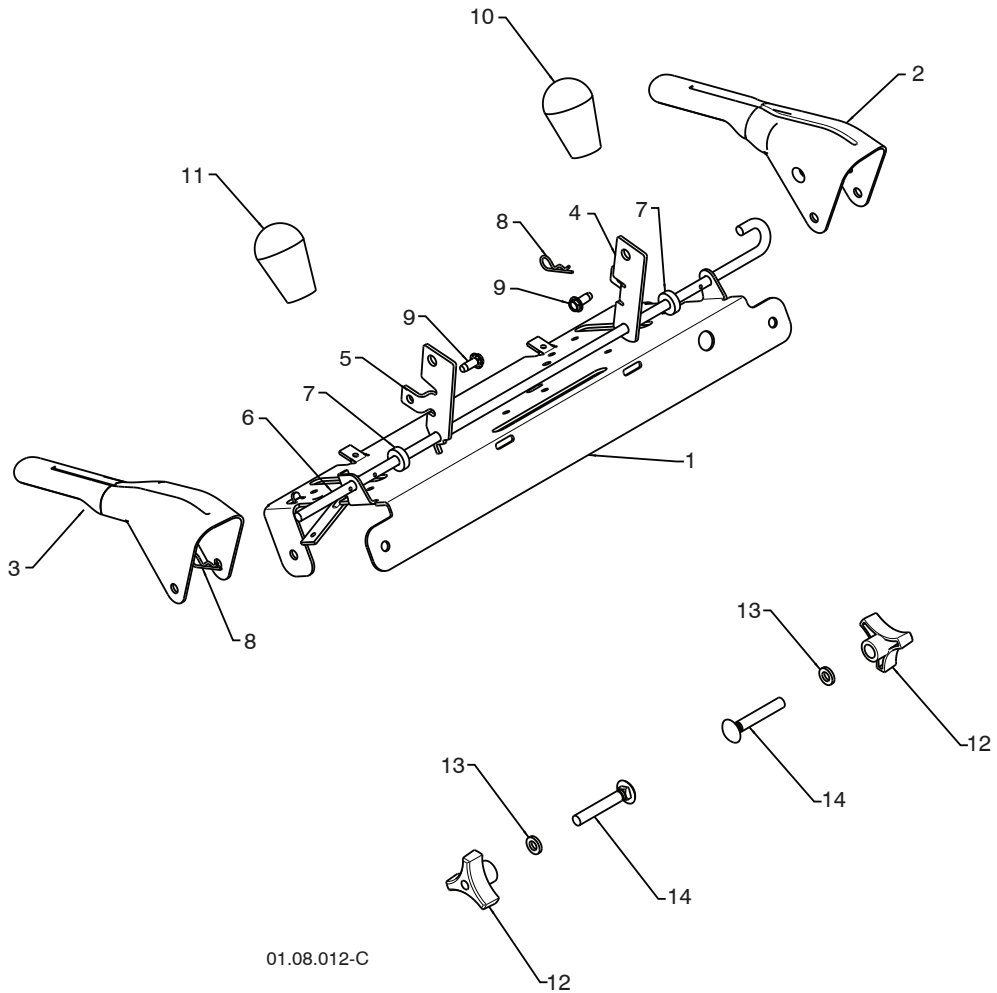

01.08.012-C

KEY NO.	PART NO.	DESCRIPTION
1	532 43 58-04	CONTROL PANEL
2	532 42 91-50	CONTROL LEVER LH
3	532 42 91-51	CONTROL LEVER RH
4	532 41 55-46	TRACTION ROD ARM
5	532 42 90-98	IMPELLER ROD ARM
6	532 41 26-77	INTERLOCK ROD
7	532 42 16-13	SPACER
8	532 16 96-75	RETAINER
9	817 06 04-10	SCREW 1/4-20 X .50
10	532 41 42-80	KNOB BLACK
11	532 41 42-81	KNOB RED
12	532 17 88-99	HANDLE KNOB
13	819 13 13-16	WASHER 3/8
14	872 12 06-18	CARRIAGE BOLT 3/8-16 X 2.25

NOTE: All component dimensions given in U.S. inches. 1 inch = 25.4 mm
IMPORTANT: Use only Original Equipment Manufacturer (O.E.M.) replacement parts. Failure to do so could be hazardous, damage your snow thrower and void your warranty.

REPAIR PARTS

HANDLES

SNOW THROWER - MODEL NO. **16530 EXL** (96193006901), PRODUCT NO. 961 93 00-69

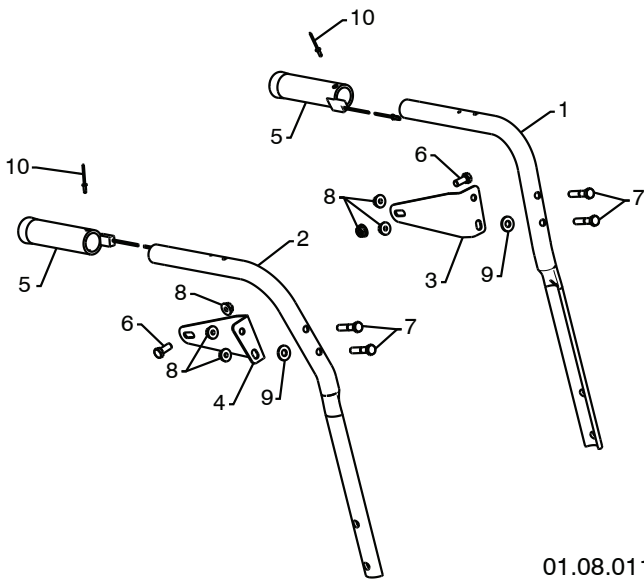

KEY NO.	PART NO.	DESCRIPTION
1	532 42 17-08	PLOW HANDLE LH
2	532 42 17-09	PLOW HANDLE RH
3	532 43 62-73	PANEL BRACKET LH
4	532 43 62-72	PANEL BRACKET RH
5	532 41 45-15	HEATED HANDLE GRIP
6	874 78 05-12	SCREW 5/16-18 X .750
7	874 78 05-24	SCREW 5/16-18 X 1.50
8	532 75 11-53	NUT 5/16-18
9	532 15 54-15	WASHER
10	532 17 87-75	POP RIVET 1/8

01.08.011-A

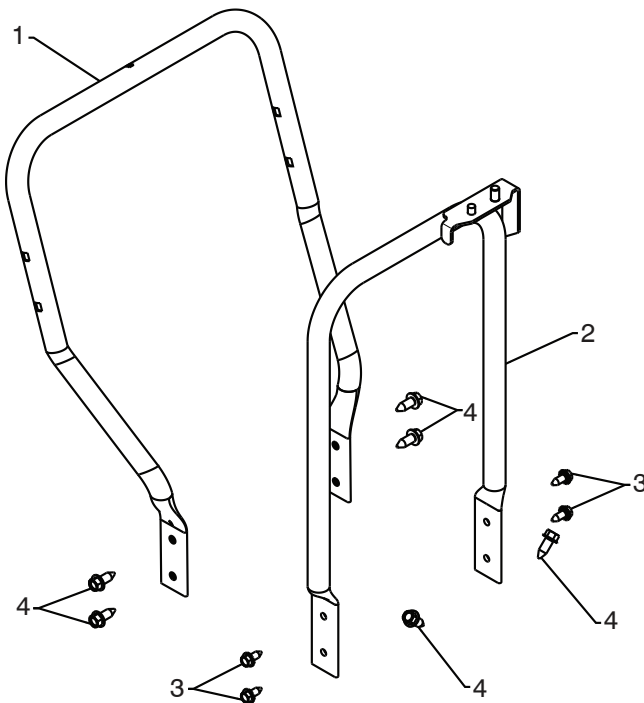

KEY NO.	PART NO.	DESCRIPTION
1	532 43 60-43	LOWER HANDLE
2	532 43 61-41	PIVOT SUPPORT
3	532 42 88-67	BOLT 5/16-18 X .750
4	817 00 06-16	SCREW 3/8-16 X 1.00

01.05.009-C

NOTE: All component dimensions given in U.S. inches. 1 inch = 25.4 mm
IMPORTANT: Use only Original Equipment Manufacturer (O.E.M.) replacement parts.
 Failure to do so could be hazardous, damage your snow thrower and void your warranty.

REPAIR PARTS

HANDLES

SNOW THROWER - MODEL NO. 16530 EXL (96193006901), PRODUCT NO. 961 93 00-69

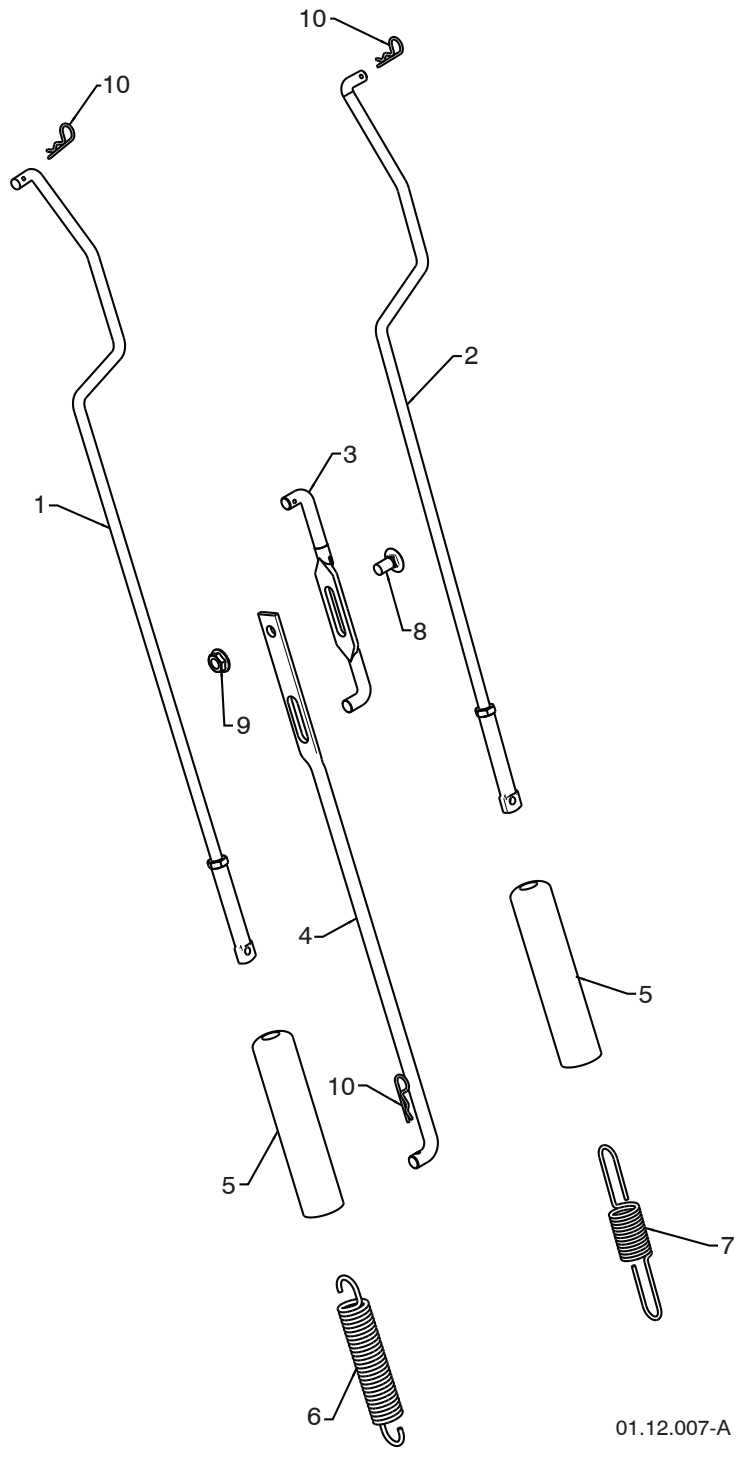

KEY NO.	PART NO.	DESCRIPTION
1	532 18 04-80	IMPELLER ROD ASSEMBLY
2	532 42 98-32	TRACTION ROD ASSEMBLY
3	532 42 55-98	SHIFTER ROD TOP
4	532 18 77-84	SHIFTER ROD BOTTOM
5	532 18 04-47	SPRING SLEEVE
6	532 17 86-69	IMPELLER SPRING
7	532 18 09-26	TRACTION SPRING
8	872 27 05-05	CARRIAGE BOLT 5/16-18 X .750
9	532 15 53-77	NUT 5/16-18
10	532 16 96-75	RETAINER

01.12.007-A

NOTE: All component dimensions given in U.S. inches. 1 inch = 25.4 mm
IMPORTANT: Use only Original Equipment Manufacturer (O.E.M.) replacement parts.
 Failure to do so could be hazardous, damage your snow thrower and void your warranty.

REPAIR PARTS

HANDLES

SNOW THROWER - MODEL NO. **16530 EXL** (96193006901), PRODUCT NO. 961 93 00-69

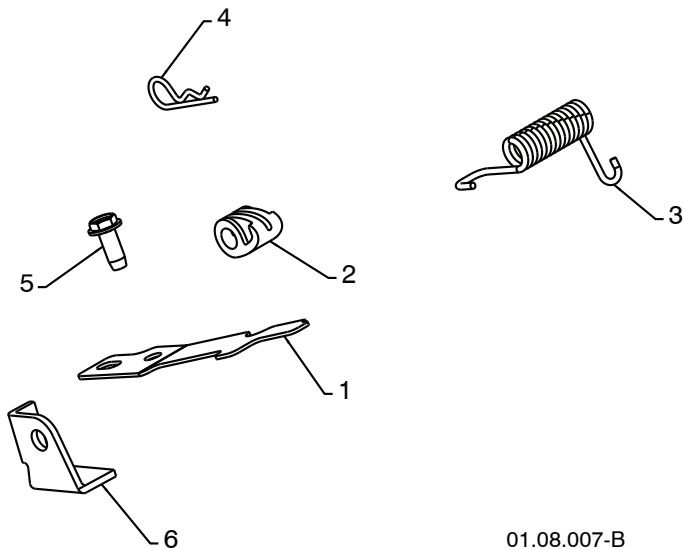

KEY NO.	PART NO.	DESCRIPTION
1	532 43 58-06	INTERLOCK SPRING
2	532 41 45-72	INTERLOCK CAM
3	532 17 88-31	TORSION SPRING
4	532 16 96-75	RETAINER
5	817 06 04-10	SCREW 1/4-20 X .625
6	532 43 58-05	INTERLOCK STOP

01.08.007-B

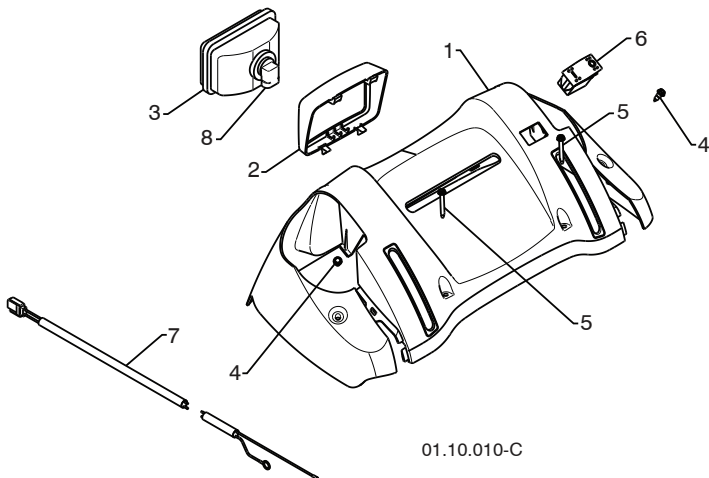

KEY NO.	PART NO.	DESCRIPTION
1	421351	CONSOLE PANEL GRAY
2	421448	HEADLIGHT BEZEL GRAY
3	178666	HALOGEN HEADLIGHT
4	184471	SHOULDERSCREW 10-24X.625
5	175262	SCREW 10-24 X 1.25
6	417760	GRIP SWITCH
7	405699	WIRE HARNESS
8	401620	BULB

01.10.010-C

NOTE: All component dimensions given in U.S. inches. 1 inch = 25.4 mm
IMPORTANT: Use only Original Equipment Manufacturer (O.E.M.) replacement parts.
 Failure to do so could be hazardous, damage your snow thrower and void your warranty.

REPAIR PARTS

DRIVE

SNOW THROWER - MODEL NO. 16530 EXL (96193006901), PRODUCT NO. 961 93 00-69

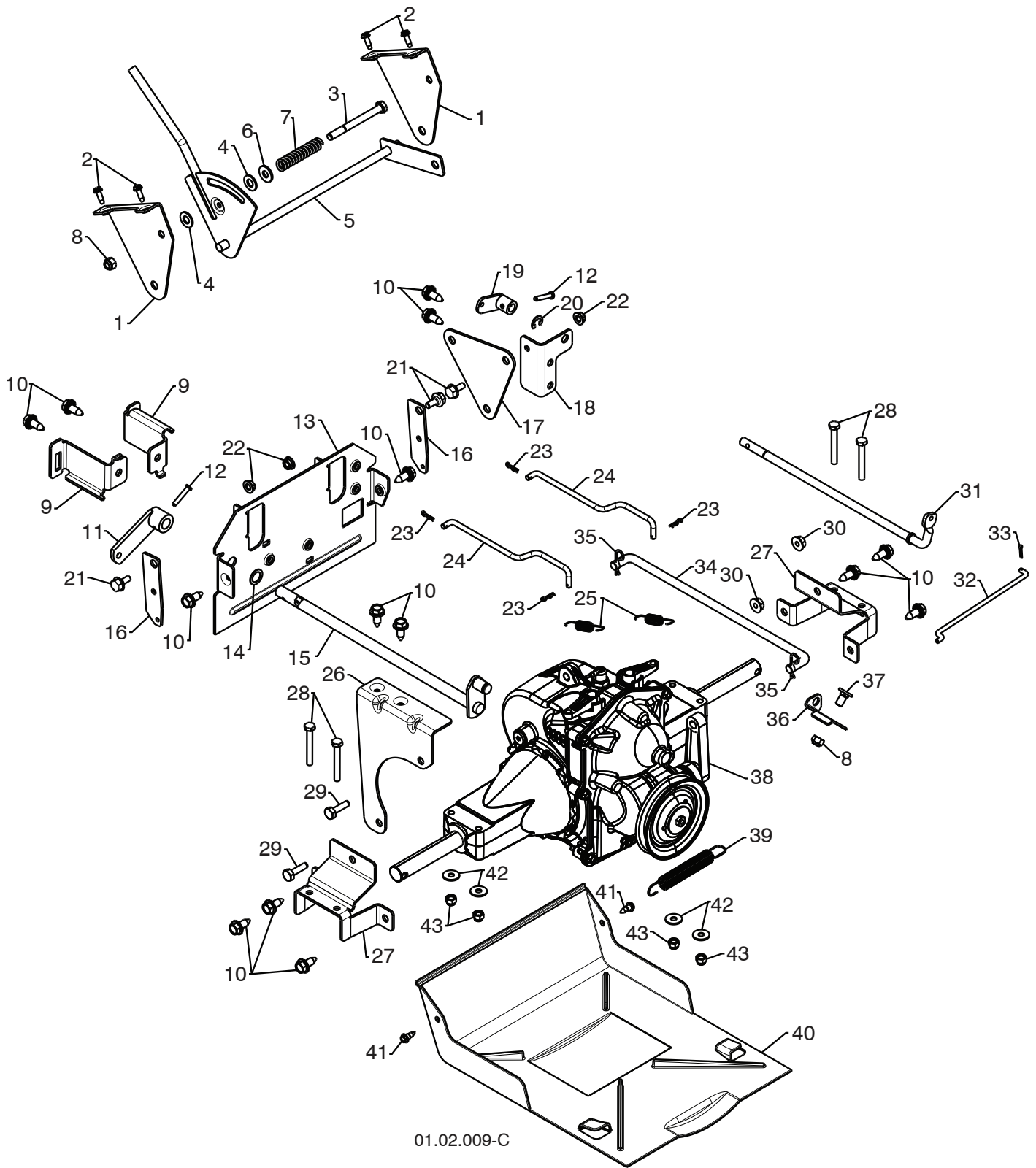

01.02.009-C

NOTE: All component dimensions given in U.S. inches. 1 inch = 25.4 mm
IMPORTANT: Use only Original Equipment Manufacturer (O.E.M.) replacement parts.
Failure to do so could be hazardous, damage your snow thrower and void your warranty.

REPAIR PARTS**DRIVE****SNOW THROWER - MODEL NO. 16530 EXL (96193006901), PRODUCT NO. 961 93 00-69**

KEY NO.	PART NO.	DESCRIPTION
1	532 19 20-02	SHIFT BRACKET
2	817 50 10-10	SCREW 10-24 X .625
3	874 76 05-52	SCREW 5/16-18 X 3.25
4	532 17 92-46	PLASTIC WASHER
5	532 42 55-96	SHIFT ASSEMBLY
6	532 15 54-15	WASHER
7	532 19 21-95	FRICTION SPRING
8	873 80 05-00	NUT 5/16-18 NYLOCK
9	532 42 79-44	CABLE MOUNTING BRACKET RH
10	532 42 88-67	SCREW 5/16-18 X .750
11	532 40 54-85	CONTROL ARM
12	532 19 85-80	CLEVIS PIN
13	532 43 71-51	REAR PLATE
14	532 05 70-79	WASHER
15	532 42 75-42	CONTROL SHAFT
16	532 42 55-34	STEER LEVER
17	532 42 55-45	PIVOT PLATE
18	532 42 55-43	REAR CLUTCH BRACKET
19	532 19 82-49	CLUTCH ARM
20	532 42 82-88	E-RING .375
21	532 40 28-81	SHOULDER BOLT 1/4-20
22	532 19 17-30	NUT 1/4-20 SIDELOCK
23	532 06 53-22	HAIRPIN RETAINER SMALL
24	532 42 54-96	STEER ROD
25	532 19 41-24	RETURN SPRING
26	532 43 71-50	STABILIZER BRACKET
27	532 43 71-49	TRANSMISSION MOUNTING BRACKET
28	874 88 04-32	SCREW 1/4-20 X 2.00
29	874 76 05-16	BOLT 5/16-18 X 1.00
30	532 75 11-53	NUT 5/16-18 X 1.00
31	532 19 82-51	CLUTCH SHAFT
32	532 19 82-50	CLUTCH ROD
33	532 70 02-79	RETAINER CLIP
34	532 42 54-99	SPEED CONTROL ROD
35	532 16 96-75	HAIRPIN RETAINER LARGE
36	532 19 82-47	FRONT CLUTCH BRACKET
37	532 18 03-55	CARRIAGE BOLT 5/16-18 X .625
38	532 42 53-94	HYDROSTATIC TRANSMISSION
39	532 17 88-28	BRAKE SPRING
40	532 42 54-98	BOTTOM PAN
41	532 18 44-71	SHOULDER SCREW 10-24
42	532 05 38-47	WASHER
43	873 80 04-00	NUT 1/4-20 NYLOCK

NOTE: All component dimensions given in U.S. inches. 1 inch = 25.4 mm

IMPORTANT: Use only Original Equipment Manufacturer (O.E.M.) replacement parts. Failure to do so could be hazardous, damage your snow thrower and void your warranty.

REPAIR PARTS

DRIVE

SNOW THROWER - MODEL NO. **16530 EXL** (96193006901), PRODUCT NO. 961 93 00-69

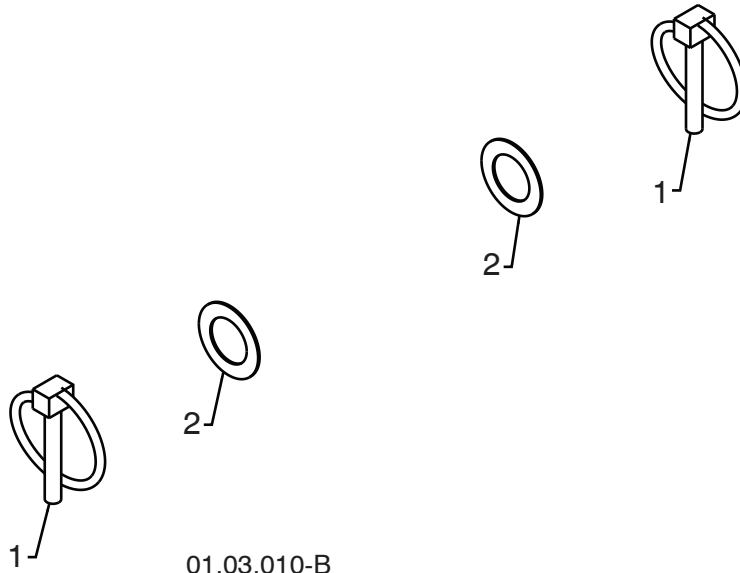

01.03.010-B

KEY NO.	PART NO.	DESCRIPTION
1	532 15 54-43	KLIK PIN
2	532 00 62-66	THRUST WASHER

NOTE: All component dimensions given in U.S. inches. 1 inch = 25.4 mm
IMPORTANT: Use only Original Equipment Manufacturer (O.E.M.) replacement parts.
Failure to do so could be hazardous, damage your snow thrower and void your warranty.

REPAIR PARTS

CHASSIS / ENGINE / PULLEYS

SNOW THROWER - MODEL NO. 16530 EXL (96193006901), PRODUCT NO. 961 93 00-69

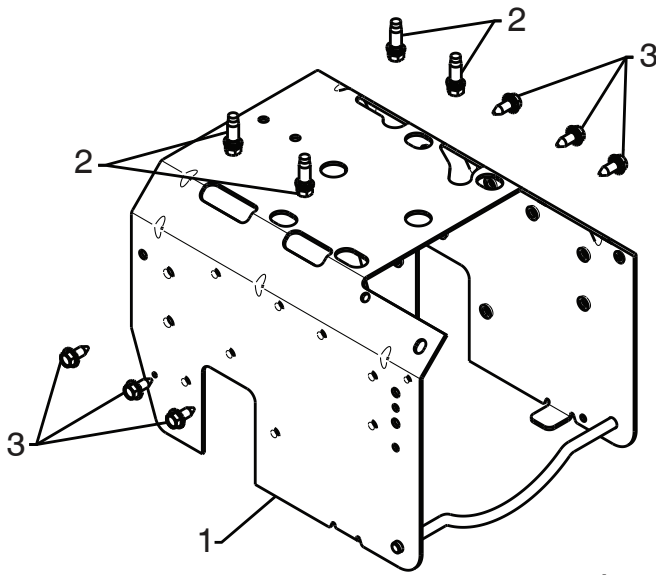

01.00.032-A

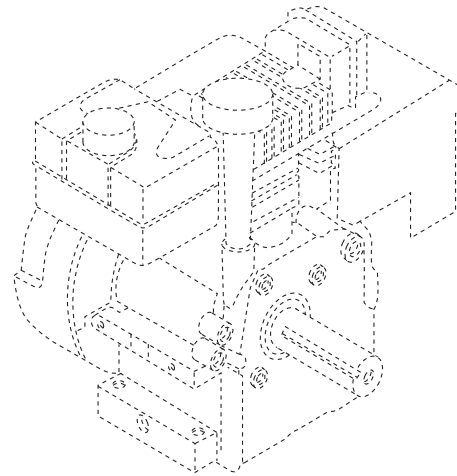

KEY NO.	PART NO.	DESCRIPTION
--	-----	B&S ENGINE MODEL 21M314-1481-E2
1	532 43 71-41	FRAME
2	532 15 04-06	BOLT 3/8-16
3	532 42 88-67	SCREW 5/16-18 X .750

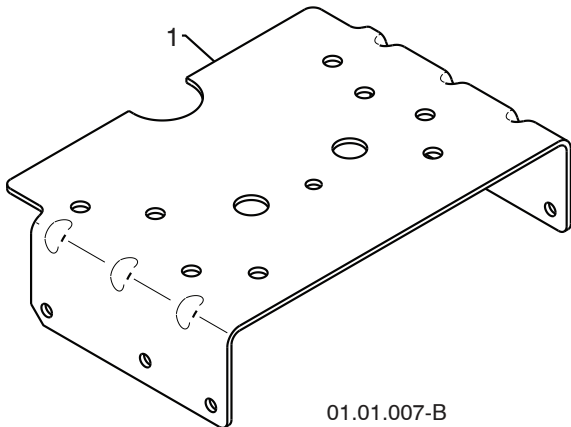

01.01.007-B

KEY NO.	PART NO.	DESCRIPTION
1	532 43 63-11	ENGINE MOUNT PLATE

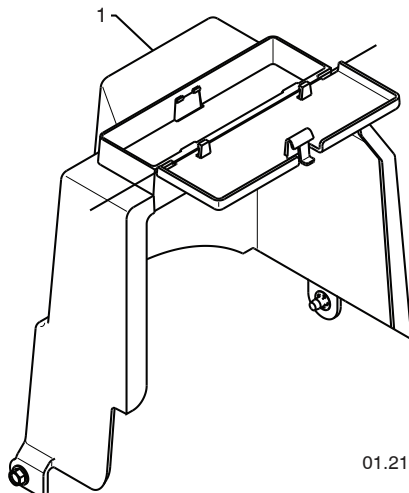

01.21.013-B

KEY NO.	PART NO.	DESCRIPTION
1	532 42 86-84	COVER ASM

NOTE: All component dimensions given in U.S. inches. 1 inch = 25.4 mm
IMPORTANT: Use only Original Equipment Manufacturer (O.E.M.) replacement parts. Failure to do so could be hazardous, damage your snow thrower and void your warranty.

REPAIR PARTS

CHASSIS / ENGINE / PULLEYS

SNOW THROWER - MODEL NO. **16530 EXL** (96193006901), PRODUCT NO. 961 93 00-69

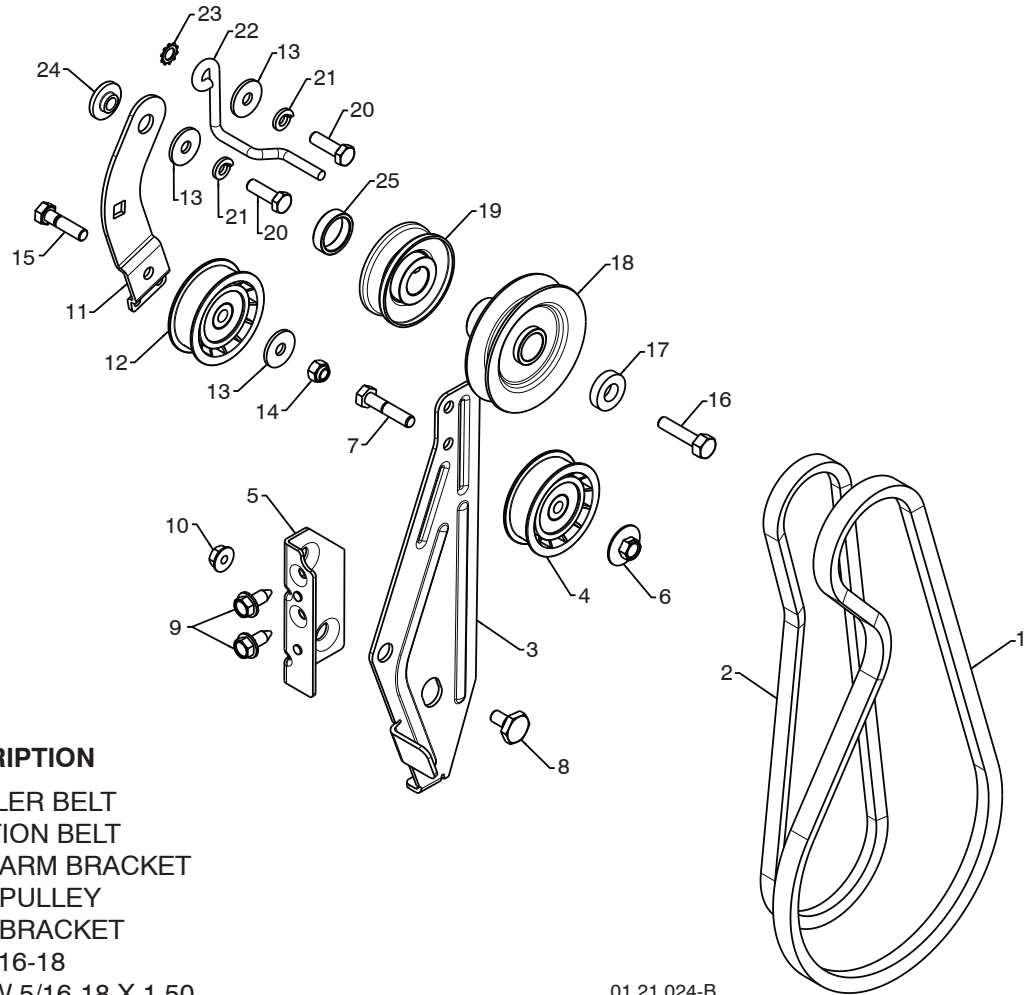

01.21.024-B

KEY NO.	PART NO.	DESCRIPTION
1	532 40 80-19	IMPELLER BELT
2	532 42 56-00	TRACTION BELT
3	532 43 58-02	IDLER ARM BRACKET
4	532 43 08-46	IDLER PULLEY
5	532 43 58-01	IDLER BRACKET
6	532 42 65-89	NUT 5/16-18
7	874 78 05-24	SCREW 5/16-18 X 1.50
8	532 42 42-97	SHOULDER BOLT 5/16-18 X .50
9	532 75 11-53	NUT 5/16-18 LOCK
10	532 42 88-67	SCREW 5/16-18 X .625
11	532 18 77-86	TRACTION IDLER BRACKET
12	532 18 05-22	TRACTION PULLEY
13	532 05 92-89	WASHER
14	873 80 05-00	NUT 5/16-18
15	874 78 05-20	SCREW 5/16-18 X 1.25
16	532 85 10-84	SCREW 3/8-24 X 1.375
17	532 40 00-26	WASHER
18	532 42 64-92	PULLEY ENG IMPELLER
19	532 18 04-78	PULLEY ENG TRACTION
20	874 61 05-16	SCREW 5/16-24 X 1.00
21	810 04 05-00	LOCKWASHER 5/16
22	532 43 00-36	BELT GUIDE
23	811 05 05-00	LOCKWASHER 5/16
24	532 17 53-31	IDLER BUSHING
25	532 40 94-75	SPACER

NOTE: All component dimensions given in U.S. inches. 1 inch = 25.4 mm
IMPORTANT: Use only Original Equipment Manufacturer (O.E.M.) replacement parts.
 Failure to do so could be hazardous, damage your snow thrower and void your warranty.

REPAIR PARTS

WHEELS

SNOW THROWER - MODEL NO. **16530 EXL** (96193006901), PRODUCT NO. 961 93 00-69

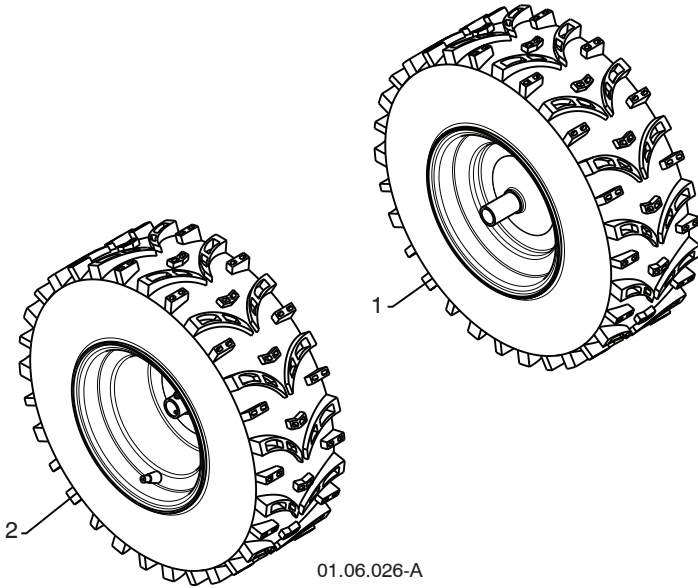

KEY NO.	PART NO.	DESCRIPTION
1	532 43 71-45	WHEEL ASSEMBLY LH
2	532 43 71-46	WHEEL ASSEMBLY RH

NOTE: All component dimensions given in U.S. inches. 1 inch = 25.4 mm
IMPORTANT: Use only Original Equipment Manufacturer (O.E.M.) replacement parts.
Failure to do so could be hazardous, damage your snow thrower and void your warranty.

REPAIR PARTS

BAG OF PARTS

SNOW THROWER - MODEL NO. 16530 EXL (96193006901), PRODUCT NO. 961 93 00-69

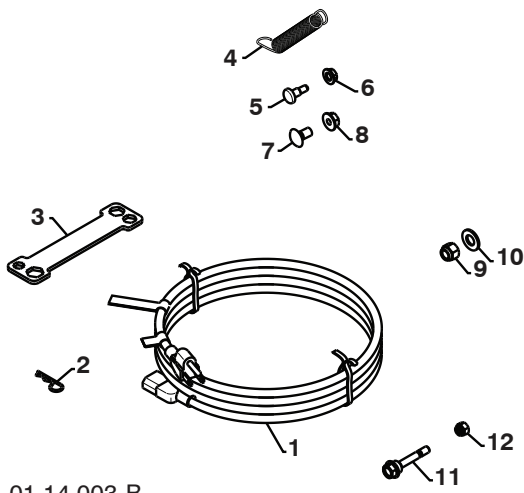

01.14.003-B

KEY NO.	PART NO.	DESCRIPTION
1	532 19 85-63	POWER CORD
2	532 16 96-75	RETAINER PIN
3	532 42 91-12	WRENCH
4	532 18 45-05	REMOTE SPRING
5	532 17 98-29	SHOULDER BOLT 1/4-20
6	532 19 17-30	LOCKNUT 1/4-20
7	872 25 05-05	CARRIAGE BOLT 5/16-18 X 5/8
8	532 75 11-53	LOCKNUT 5/16-18
9	873 80 06-00	LOCKNUT 3/8-16
10	819 13 13-16	WASHER 3/8
11	532 19 20-90	SHEAR BOLT 1/4-20 X 1-13/16
12	873 80 04-00	LOCKNUT 1/4-20

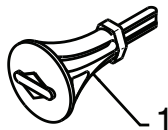

01.14.007-A

KEY NO.	PART NO.	DESCRIPTION
1	532 19 30-71	SAFETY IGNITION KEY

NOTE: All component dimensions given in U.S. inches. 1 inch = 25.4 mm
IMPORTANT: Use only Original Equipment Manufacturer (O.E.M.) replacement parts.
 Failure to do so could be hazardous, damage your snow thrower and void your warranty.

REPAIR PARTS

BAG OF PARTS

SNOW THROWER - MODEL NO. **16530 EXL** (96193006901), PRODUCT NO. 961 93 00-69

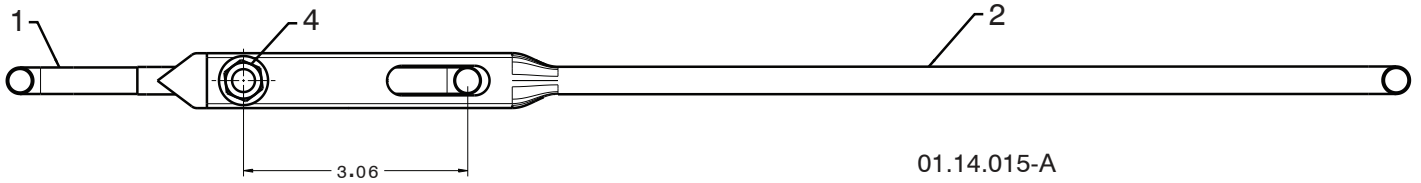
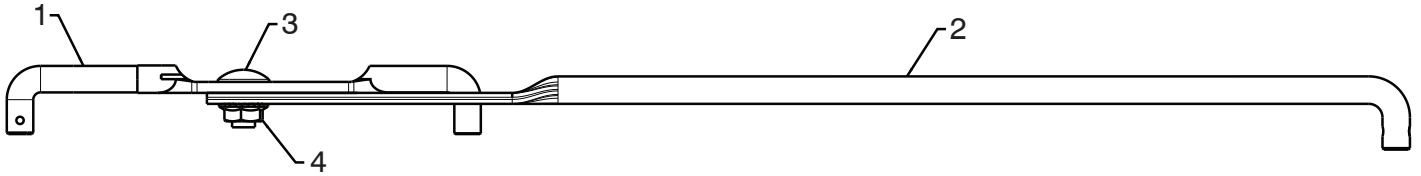

KEY NO.	PART NO.	DESCRIPTION
1	532 42 55-98	SHIFTER ROD TOP
2	532 18 77-84	SHIFTER ROD BOTTOM
3	872 27 05-05	CARRIAGE BOLT 5/16-18 X .75
4	532 15 53-77	NUT 5/16-18

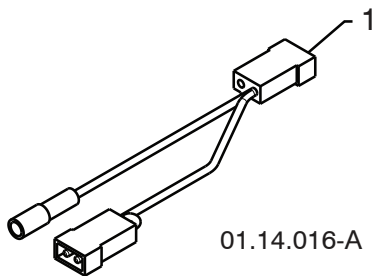

KEY NO.	PART NO.	DESCRIPTION
1	532 43 58-40	KIT HARNESS CONN B&S

NOTE: All component dimensions given in U.S. inches. 1 inch = 25.4 mm
IMPORTANT: Use only Original Equipment Manufacturer (O.E.M.) replacement parts.
 Failure to do so could be hazardous, damage your snow thrower and void your warranty.

REPAIR PARTS

DECALS

SNOW THROWER - MODEL NO. 16530 EXL (96193006901), PRODUCT NO. 961 93 00-69

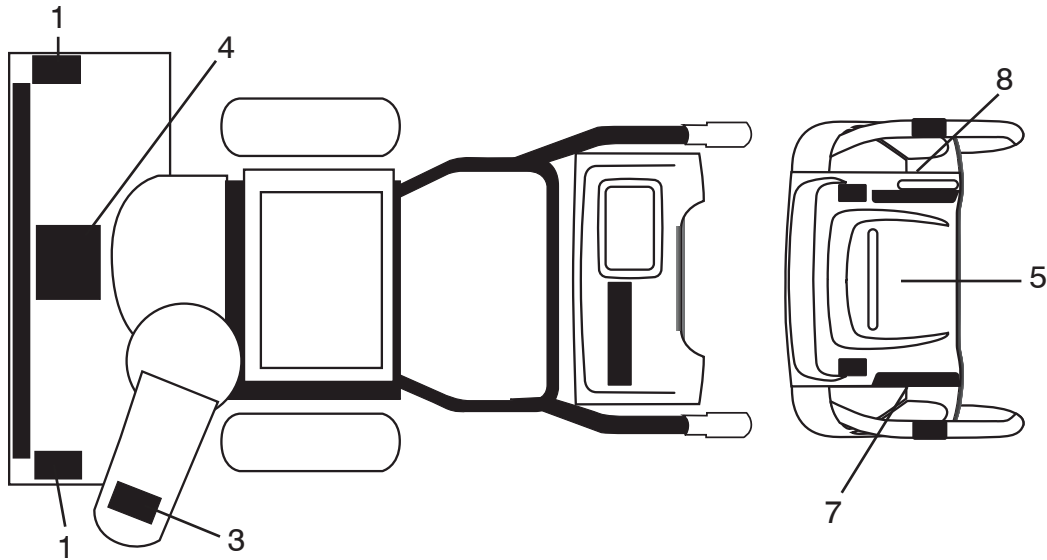

KEY NO.	PART NO.	DESCRIPTION
1	532 18 10-37	DECAL, DANGER
3	532 18 10-35	DECAL, DANGER, DEFLECTOR
4	532 18 10-42	DECAL, DANGER
5	532 42 95-73	DECAL, INSTRUCTION
7	532 42 95-69	DECAL, LH TRIGGER
8	532 42 95-71	DECAL, RH TRIGGER
--	532 43 58-96	OPERATOR'S MANUAL, ENGLISH
--	532 43 58-97	OPERATOR'S MANUAL, FRENCH

NOTE: All component dimensions given in U.S. inches. 1 inch = 25.4 mm
IMPORTANT: Use only Original Equipment Manufacturer (O.E.M.) replacement parts.
Failure to do so could be hazardous, damage your snow thrower and void your warranty.