

Operator's manual

DT22



Please read these instructions carefully and make sure you understand them before using the machine.

English

CONTENTS

Introduction.....	4	Operation.....	18
Good service.....	4	Before Starting.....	18
Serial Number.....	4	Dethatching.....	18
Symbols and Decals.....	6	Finishing.....	18
Decals.....	6	Seed Application.....	19
Decal Locations.....	7	Preparing the Lawn.....	19
Safety.....	8	Seed Application Chart.....	19
General Use.....	8	Seed Application Recommendations.....	19
Preparations.....	9	Bagger Attachment and Removal.....	19
Operating.....	10	Maintenance.....	20
Movement/Transport.....	11	Maintenance Schedule.....	20
Children.....	11	Drive Belt.....	21
Storage.....	11	Cleaning and Washing.....	21
Fuel System.....	12	Flail blades.....	22
Maintenance.....	13	Two Minute Rule.....	23
Assembly.....	14	Delta Blades.....	24
Controls.....	15	Spring tines.....	24
Engine.....	16	Lubrication Schedule.....	25
Fueling.....	16	Lubrication.....	25
Cutting Unit.....	16	Conformity Certificates.....	26
Depth Lever.....	16	Troubleshooting.....	27
Clutch.....	16	Storage.....	28
Blade versatility.....	17	Winter storage.....	28
Flail Blades.....	17	Service.....	28
Delta Blades.....	17	Technical Data.....	29
Spring Tines.....	17	Service Journal.....	30

INTRODUCTION

Congratulations

Thank you for purchasing a Husqvarna lawn care product. Through your confidence in us, you have chosen an exceptionally high quality product.

This manual is a valuable document. It describes your new Husqvarna machine. Read the manual carefully before attempting to use the machine. Following the instructions (use, service, maintenance, etc.) can considerably increase the lifespan of your machine and even increase its resale value. Please contact your dealer for more information.

If you sell your Husqvarna machine, make sure to give the operator's manual to the new owner.

Insure your machine

Contact your insurance company to check on insurance coverage for your new machine. You should have all-inclusive insurance for liability, fire, damage and theft.

Good service

Husqvarna's products are available only in specialized retail trades with complete service. This ensures that you as a customer get only the best support and service. Before the machine was delivered it underwent inspection and was adjusted by your dealer. When you need spare parts or support in service questions, guarantee issues, etc., please consult the following professional:

This Parts Manual belongs to the machine with the manufacturing number:	Engine:

Serial Number

The machine's serial number can be found on the printed plate attached to the rear side panel of the machine. The plate includes the following information:

- The machine's type designation (MODEL).
- The machine's serial number (S/N).

Please state the type designation and serial number when ordering spare parts.

The engine's serial number is printed on the engine.

The engine type is specified on the crankcase under the air filter.

Please state engine serial number and type when ordering replacement engine parts.

SAFETY

General Information

This manual will assist you in the safe operation and proper maintenance of your Husqvarna equipment. Read it thoroughly before attempting to operate the machine. Call your dealer or Husqvarna if additional information is required.

This equipment should not be modified without the manufacturer's prior written authorization. Doing so may not only affect the equipment's performance and durability, but also create safety hazards for the operator and the surroundings. Warranty will be void if changes are made to the equipment without the manufacturer's prior written authorization.

Safety Procedures

DO

- Read all maintenance and service instructions before attempting work.
- Read engine manufacturer's operating and maintenance instructions.
- Remove spark plug wire before commencing service.
- Before starting, inspect the lawn and remove rocks, wire, string and other objects that might present a hazard.
- Identify and mark all ground objects to be avoided, such as sprinkler heads, stakes, water valves, or clothes line anchors.
- Keep unsupervised children away from the equipment.
- Adopt safe lifting and moving techniques when loading/unloading and moving the equipment.
- Make sure all decals are in place.
- Use the machine only for sowing and dethatching lawns.

DO NOT

- Do not use on any surface other than grass.
- Do not operate on slopes exceeding 35% grade.
- Do not place hands or feet near moving or rotating parts.
- Do not lift alone.
- Do not run engine in an unventilated space.
- Do not run engine while servicing. Remove spark plug wire before commencing service.
- Do not smoke or allow open flames or sparks near unit, and always stop the engine when refueling.
- Do not remove guards when operating.
- Do not modify this equipment.

SYMBOLS AND DECALS

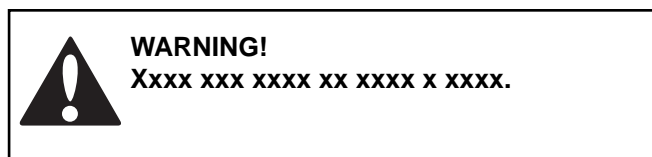

Used in this publication to notify the reader of a risk of **personal injury**, particularly if the reader should neglect to follow instructions given in the manual.

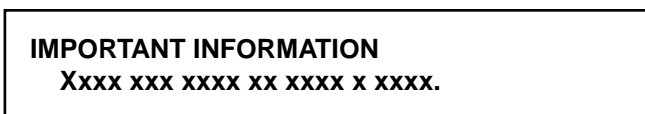

Used in this publication to notify the reader of a risk of **material damage**, particularly if the reader should neglect to follow instructions given in the manual. Used also when there is a potential for misuse or misassembly.

Decals

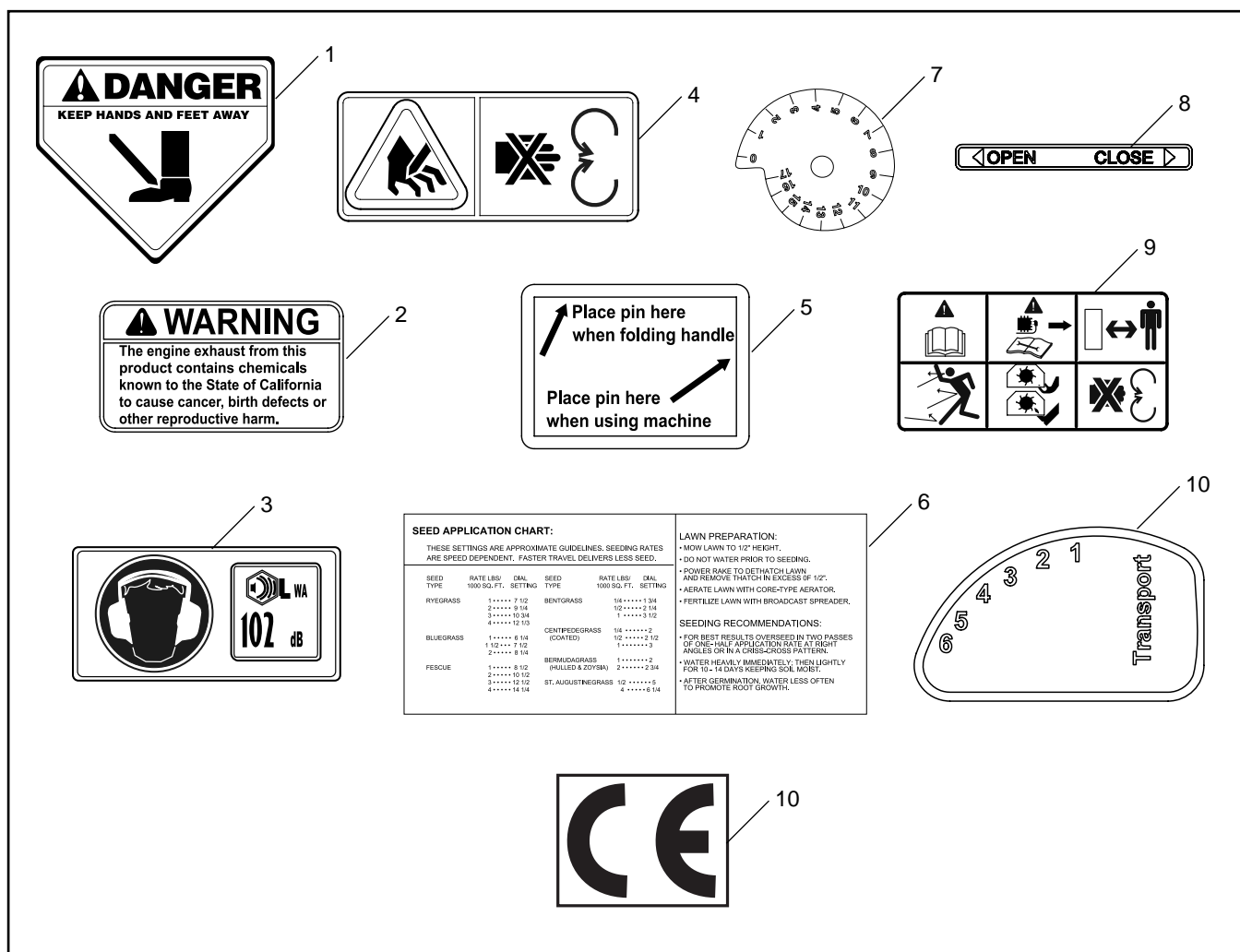

1. DANGER watch your feet
2. Warning for carbon monoxide
3. Noise emission to the environment according to the European Community's Directive. The machine's emission is specified in Technical data and on the label.
4. Warning for bagger
5. Handle folding instructions
6. Seed application chart
7. Seeder Dial
8. Open/Close (Seedbox)
9. Caution graphics
10. Height setting
11. CE conformity marking, only for European market

SYMBOLS AND DECALS

Decal Locations

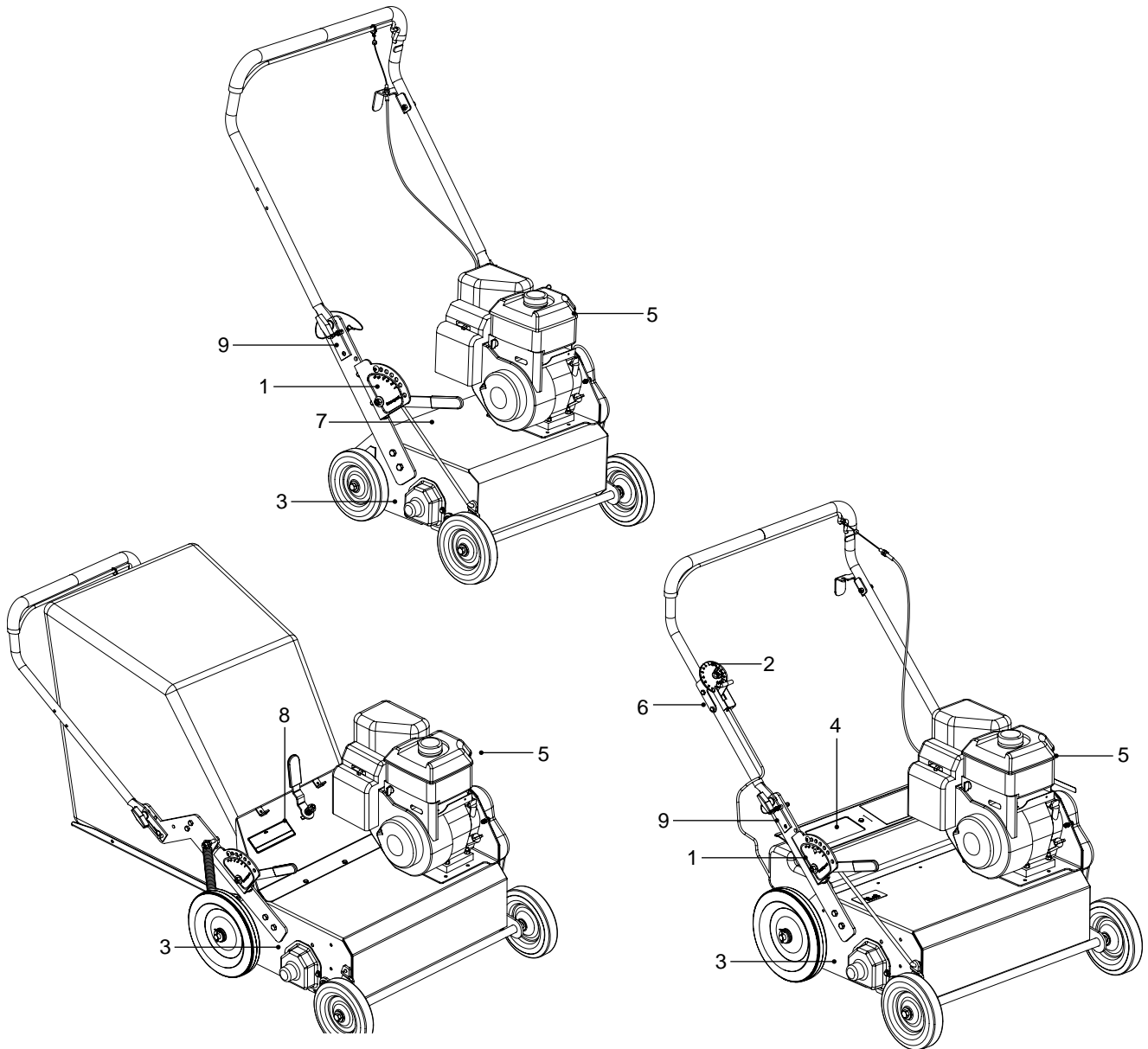

1. Height setting
2. Seeder Dial
3. DANGER watch your feet
4. Seed application chart
5. Warning for carbon monoxide

6. Open/Close (Seedbox)
7. Caution graphics
8. Warning for bagger
9. Handle folding instructions

SAFETY

General Use

The object of this manual is to help you use your Husqvarna machine safely and to give you information about how to maintain your machine. Please read the manual carefully before attempting to use the machine.

If after reading the operator's manual you are still unsure about the safety risks associated with use of the machine, you should not use the machine. Please contact your dealer for more information.

These safety instructions only address the basics for safe use. It would be impossible in the safety instructions to describe all possible risk situations that could arise when using the machine. You can, however, prevent accidents by always using common sense.

For a replacement copy of the operator's manual, contact your dealer.

IMPORTANT INFORMATION

Do not use the machine until you have read the operator's manual carefully and understand the instructions given. All maintenance work or adjustments not described in this manual must be performed by an authorized Husqvarna service workshop.

- Read this manual carefully and make sure you understand it before using the machine or performing any maintenance. If the user cannot read this manual, it is the responsibility of the machine owner to explain the contents to the user.
- Follow all safety instructions. Failure to do so may result in injury to yourself or others.
- Accident prevention regulations, other general safety regulations, occupational safety rules and traffic regulations must be followed without fail.
- All users shall be trained in use of the machine. The owner is responsible for training users.
- Engage an authorized Husqvarna workshop for all service and repairs not described in this manual.
- Husqvarna original spare parts are designed and specified to maintain high quality and correct fit for optimal durability and lifespan.
- Check that all safety decals are in place. See the section **Symbols and Decals**.
- Learn how to use the machine and its controls safely and learn to recognize the safety decals.
- Only use the machine for sowing and dethatching lawns. It is not intended for any other use.



WARNING!

Under no circumstances may the original design of the machine be modified without written approval from the manufacturer. Such modifications not only affect the performance and durability of the machine but may even pose a safety risk for users and those in the vicinity. Unauthorized modifications to the design of the machine may absolve the manufacturer from liability for any resulting personal injury or property damage. Modifying the machine without written approval from the manufacturer may void the guarantee.

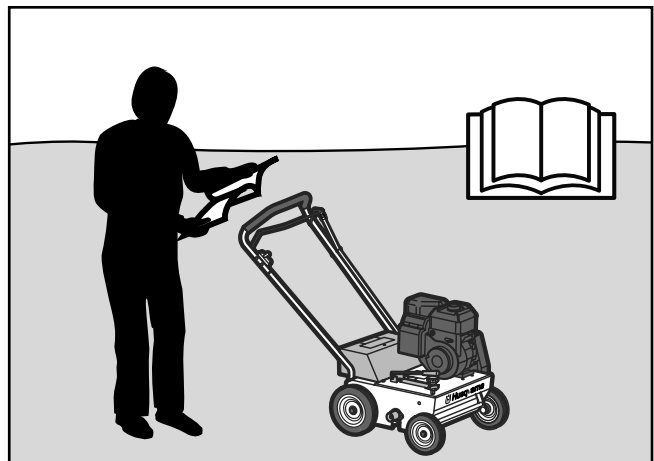

8011-040

Read this manual carefully before starting the machine



WARNING!

Overexposure to vibration may lead to circulatory or nerve damage, particularly in people who have impaired circulation. Contact your doctor if you experience symptoms that could have been caused by overexposure to vibration. Examples of common symptoms include numbness, pain, muscle weakness, change of skin color or an uncomfortable feeling of tingling. These symptoms appear most frequently in the fingers, hands or wrists.

SAFETY

- Check that the machine is in serviceable condition prior to use; see the *Maintenance Schedule* in the **Maintenance** section.
- Only use the machine in daylight or in other well-lit conditions. Keep the machine a safe distance from holes or other irregularities in the ground. Pay attention to other possible risks.
- Only allow the machine to be used by adults who are familiar with its use.
- Never allow children or persons not trained in the use of the machine to use it. Local laws may regulate the age of the user.
- People and animals can distract you causing you to lose control of the machine. For this reason, always concentrate and focus on the task at hand. Make sure animals and people maintain a safe distance from the machine.
- Never leave the machine unsupervised with the engine running.
- Make sure that other people are nearby when you are using the machine so that you can call for help should an emergency arise.
- The machine is tested and approved only with the equipment originally provided or recommended by the manufacturer.

Preparations

- Have first aid equipment at hand when using the machine.
- Make sure no one else is in the vicinity of the machine when starting the engine, engaging the drive or running the machine.
- Clear the area of objects such as rocks, toys, wire, etc., which could be picked up and thrown by the blades.
- Locate fixed objects in the ground, such as sprinkler systems, poles, water valves, bases for washing lines. Check for hidden electrical cables or similar in the surface of the lawn. Run the machine around these objects. Never intentionally run the machine over foreign objects.
- Make sure all guard plates and protective shields are in place and intact when using the machine.
- Make sure no clothing, long hair or jewelry can catch in moving machine parts.
- Never use the machine when barefoot. Always wear protective shoes or protective boots with anti-slip and preferably with steel toes.
- Wear approved ear-protection when running the machine. Ask your dealer about approved ear-protection.



WARNING!

The engine can become very hot. To avoid being burned, you must turn off the engine and wait until all parts have cooled before touching the engine.

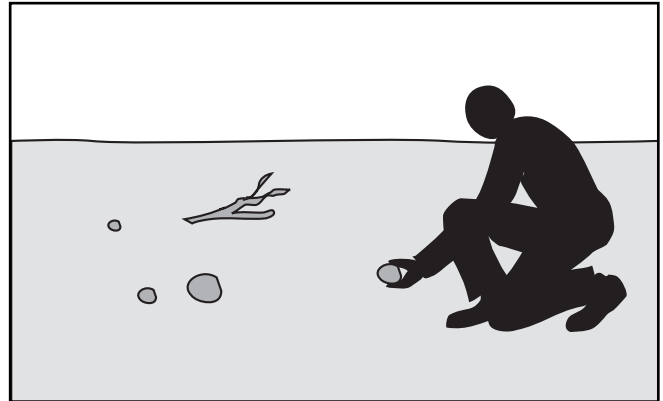

8011-198



WARNING!

Always use approved protective clothing and approved protective equipment when using the machine. Protective clothing and protective equipment cannot eliminate the risk of accidents, but wearing proper clothing and the correct equipment will reduce the degree of injury should an accident occur. Ask your dealer about approved protective clothing and approved protective equipment recommended by Husqvarna.

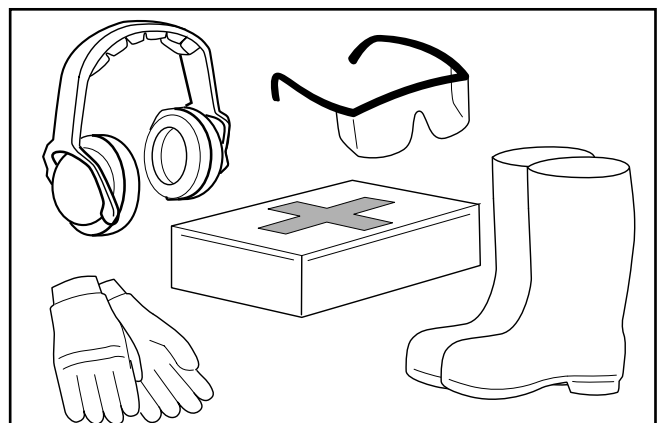

8011-670

SAFETY

Operating

- Do not use the machine on grades of more than 20°. We recommend working across slopes rather than up and down. This will yield a more even result. Do not leave the machine standing on a slope unattended.
- Do not use the machine if you are tired, if you have consumed alcohol, or if you are taking other drugs or medication that can affect your vision, judgment or co-ordination.
- Never use the machine indoors or in spaces lacking proper ventilation.
- Do not use the machine on any surface other than grass.
- Make sure you have a proper foothold when using the machine, particularly when backing. Walk, don't run. Never work on wet grass. Poor traction may cause you to slip.
- Keep your hands and feet away from moving parts.
- Keep your hands and feet away from the work tools.
- Slow down and be especially careful on slopes. Make sure to run the machine in the recommended direction on slopes. Be careful when working close to sudden changes in level.
- Smoking, open flames or sparks in the vicinity of the machine are strictly forbidden. Gasoline is extremely flammable and carelessness in handling can result in personal injury or fire.
- Stop and inspect the equipment if you run over or into anything. If necessary, make repairs before beginning again.
- Whatever happens, you should always park the machine on even ground, disengage the drive, turn off the engine and wait until all moving parts have stopped before leaving the operating position behind the machine.



WARNING!

Engine exhaust, some of its constituents and certain vehicle components contain or emit chemicals considered to cause cancer, birth defects or other reproductive harm. The engine emits carbon monoxide, which is a colorless, poisonous gas. Do not use the machine in enclosed spaces.



8011-041

The engine exhaust is poisonous. Never run the engine indoors.



8011-289

*Smoking near the machine is **strictly** prohibited*

SAFETY

Movement/Transport

- To turn and steer the machine, press down on the handle and turn on the back wheels.
- Turn off the engine and allow it to cool at least 2 minutes before transport.
- Collapse the handle if the machine is equipped with a collapsible handle.
- Be careful and use safe lifting and moving techniques when loading/unloading the machine.
- We recommend having two people to lift the machine.
- Fasten the machine properly in place with approved fasteners, such as tension belts, chains or rope. Always check that you are in compliance with applicable traffic regulations before transporting the machine.

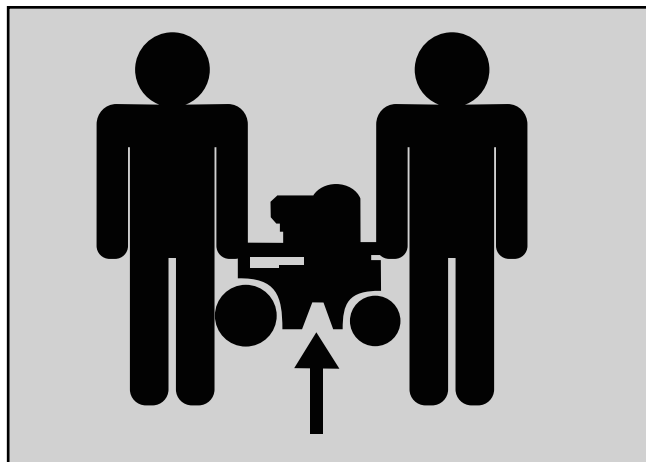

8011-090

We recommend having two people to lift the machine

Children

Serious accidents can occur if you fail to be on guard for children in the vicinity of the machine. Never assume that children will stay where you last saw them.

- Keep children away from the machine.
- Keep children away from the work area and under close supervision by another adult.
- Keep an eye out and shut off the machine if children enter the work area.
- Never allow children to operate the machine.
- Be particularly careful near corners, bushes, trees or other objects that block your view.

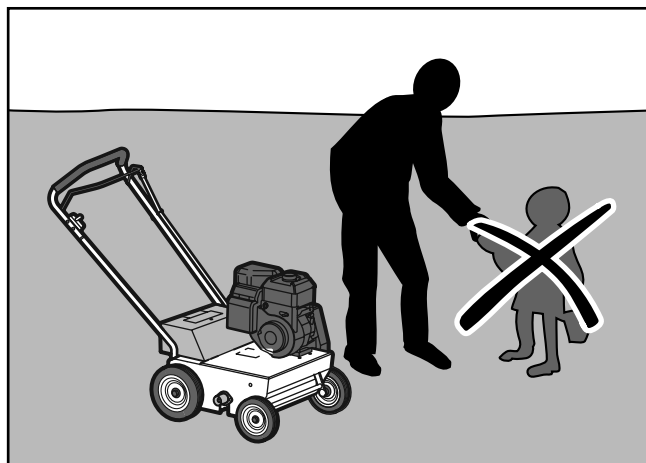

8011-039

Keep children away from the work area

Storage

- Allow the engine to cool before storing the machine. Never store the machine near an open flame.
- Store the machine with the fuel valve closed.
- Store the machine and fuel in such a way that there is no risk that leaking fuel or fumes can come in contact with flames or sparks from electrical machines, electric engines, relays, switches, boilers or similar.
- Store the machine in a locked space away from children and adults untrained in use of the machine.

SAFETY

Fuel System

- Only store fuel in containers approved for that purpose.
- Never remove the fuel cap and fill the fuel tank when the engine is running.
- Always stop the engine when refueling.
- Do not smoke when filling the gasoline tank and do not pour gasoline in the vicinity of sparks or open flame.
- Never fill the fuel tank indoors.



8011-037

Never fill the fuel tank indoors

- Before starting the machine after refueling, it should be moved at least 10 feet (3 M) from the location where it was filled.
- Turn off the fuel supply for storage or transport.
- If leaks arise in the fuel system, the engine must not be started until the problem has been resolved.
- Check the fuel level before each use and leave space for the fuel to expand, because the heat from the engine and the sun can otherwise cause the fuel to expand and overflow.
- Avoid overfilling. If you spill gasoline on the machine, wipe up the spill and wait until it has evaporated before starting the engine. If you spill gasoline on your clothing, change your clothing.

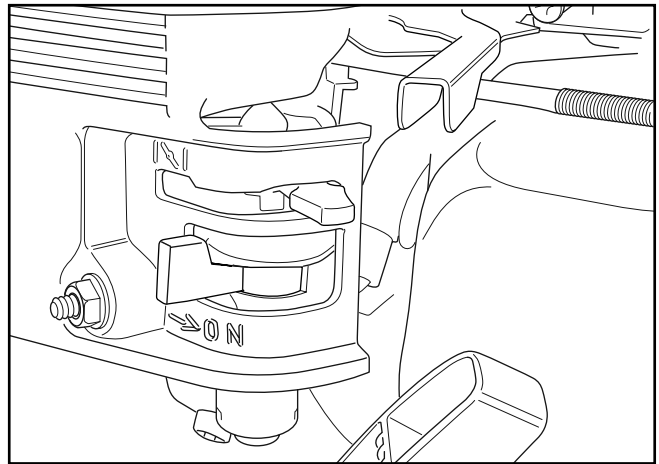

8011-036

Close the fuel valve



WARNING!
Gasoline and gasoline fumes are poisonous and extremely flammable. Be especially careful when handling gasoline, as carelessness can result in personal injury or fire.

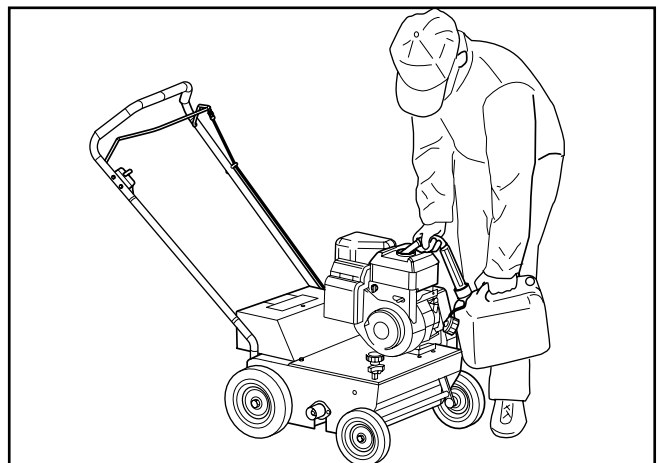

8011-019

Fueling always poses an element of risk

SAFETY

Maintenance

- Never make adjustments with the engine running.
- Disengage the drive units, shut off the engine and wait until all moving parts come to a complete stop before making adjustments, performing maintenance or cleaning the machine.
- Disconnect the spark plug cable before beginning repair work.
- Keep all components in serviceable condition and make sure all nuts, bolts, etc. are tight. Replace worn or damaged decals.
- Be careful when checking work tools. Use gloves when performing maintenance work.
- Never allow persons not trained in the use of the machine to perform service on it.
- Always park the machine on even ground before performing maintenance or making adjustments.
- Do not disassemble the engine. This can invalidate your engine warranty. Contact your dealer if you have any questions regarding service or guarantee matters. Follow all maintenance instructions.
- Do not change the setting of governors and avoid running the engine with overly high RPM. If you run the engine too fast, you risk damaging the machine components.
- Do not modify safety equipment. Check regularly to be sure it works properly. The machine must not be run with defective or disassembled safety equipment.
- The muffler is designed to maintain sound levels at an approved level and keep direct exhaust away from the user. Exhaust gases from the engine are extremely hot and may contain sparks that can cause fires or burn the user.
- Never use a machine with a defective muffler.
- Reduce the risk of fire by removing grass, leaves and other debris that may have caught in the machine.

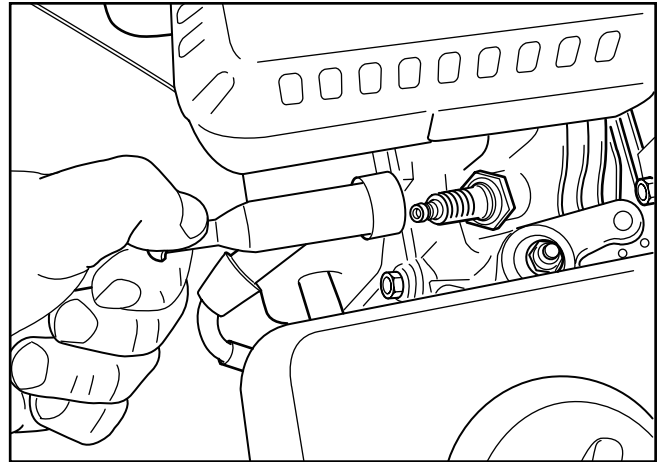

8011-027

Disconnect the spark plug cable before repair work



WARNING!

Wait until all moving parts are completely still before performing maintenance on the machine.

Turn off the engine and remove the spark plug cable.

ASSEMBLY

1. Rotate the handle and tighten it in place.
2. Fill the engine with the manufacturer-recommended oil. See section "Lubrication/Engine oil".
3. Test the clutch. Make sure that the clutch expansion spring disengages 6.35 mm (1/4") easily.

4. The engine RPM is preset by the manufacturer. Idle speed is 1250–1400 RPM. Maximum engine speed is 3600 RPM.

See the engine manual for instructions on adjusting the regulator and carburetor if the engine speed is not within these limits.

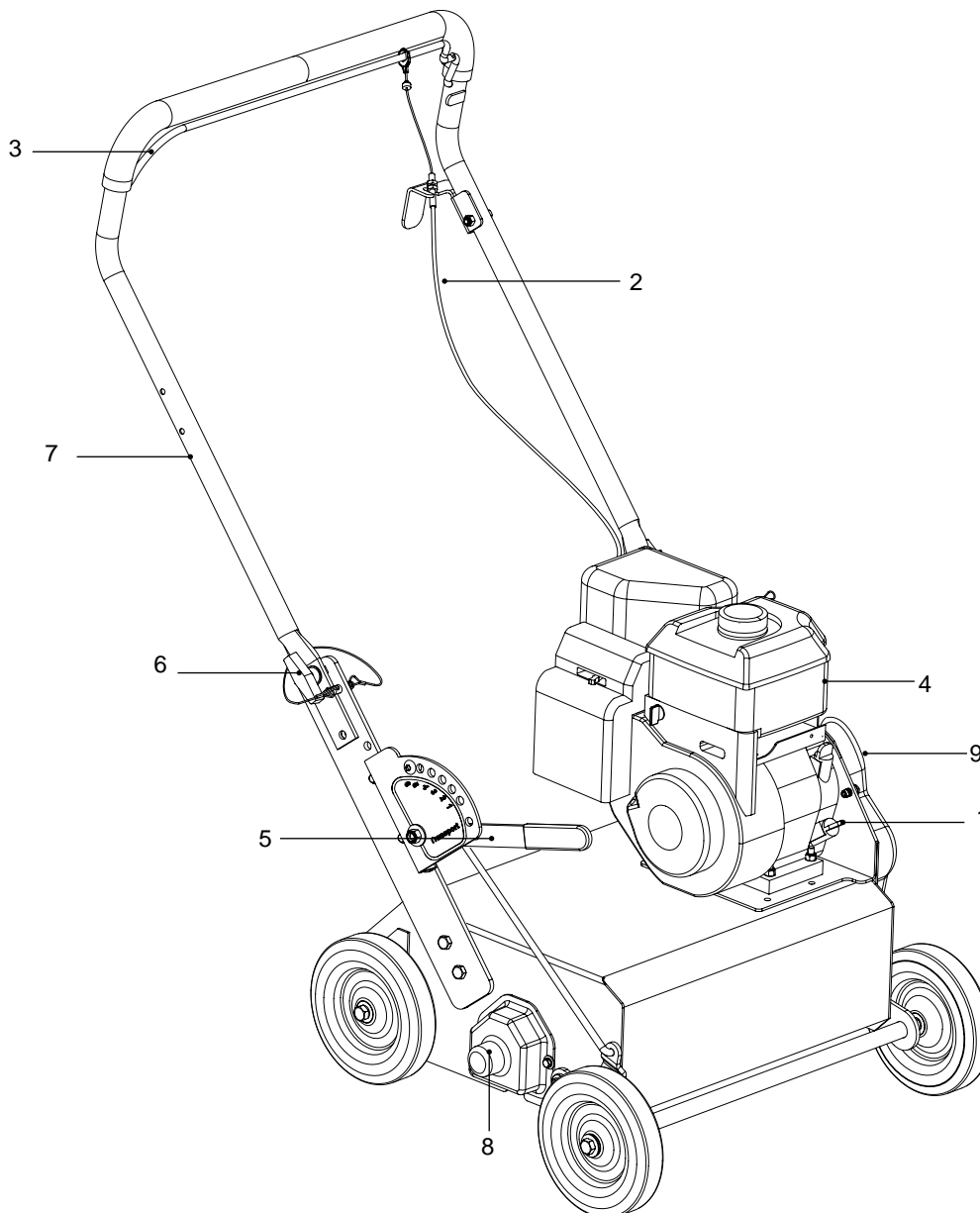

- | | |
|----------------------|--------------------------------|
| 1. Engine Oil refill | 6. Knob for collapsible handle |
| 2. Clutch cable | 7. Handle |
| 3. Clutch bail | 8. Shaft guard |
| 4. Engine | 9. Belt shield |
| 5. Depth lever | |

CONTROLS

The machine has a 22" width and is equipped with a 5.5 hp Honda four-cycle engine.*

**The power rating of the engines indicated is the average net power output (at specified rpm) of a typical production engine for the engine model measured to SAE standard J1349/ISO1585. Mass production engines may differ from this value. Actual power output for the engine installed in the final machine will depend on the operating speed, environmental conditions and other variables.*

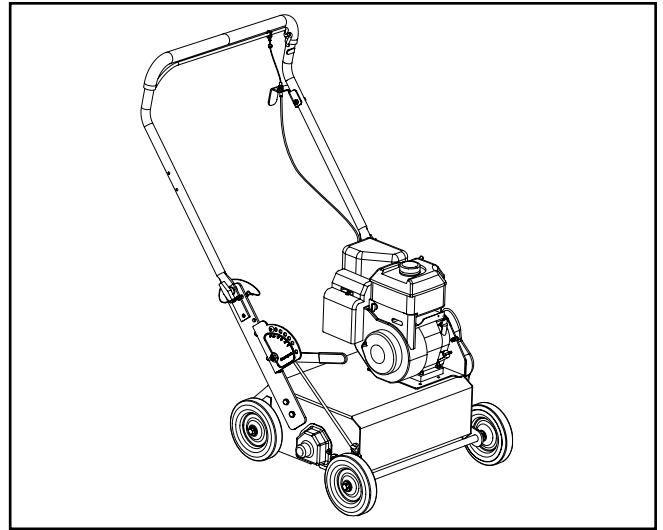

The dethatcher can be equipped with a catcher. It is available as an accessory at your Husqvarna dealer. It can be mounted after purchase.

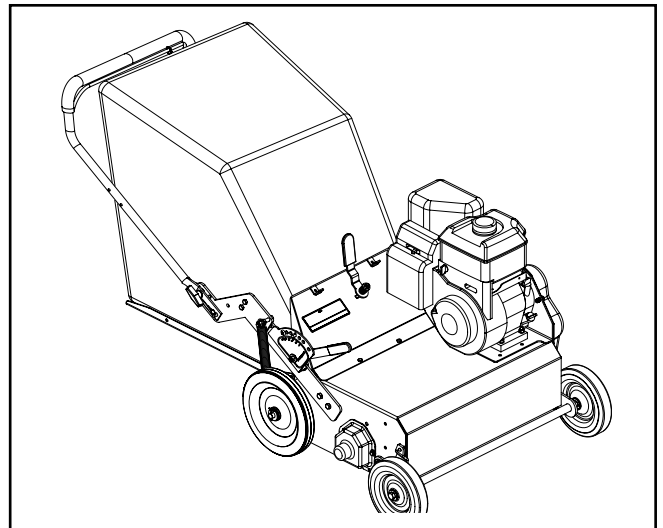

Alternatively, the dethatcher can be equipped with a seeder. It is available as an accessory at your Husqvarna dealer. It can be mounted after purchase. It is not possible to use a catcher and seeder simultaneously.

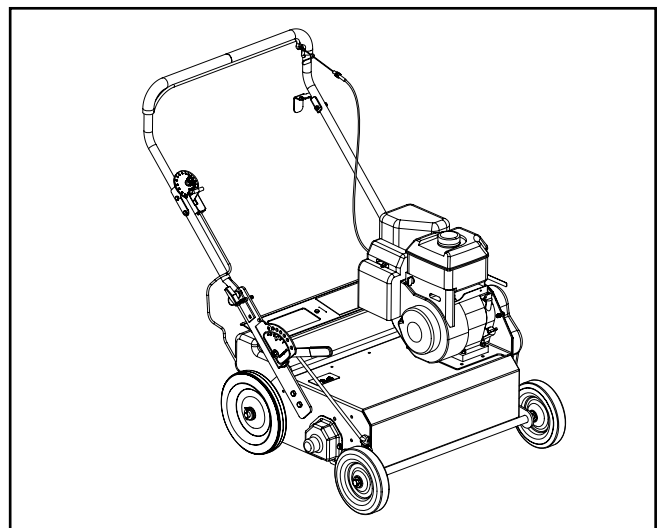

CONTROLS

Engine

Refer to your engine manual.

Fueling

Read the safety instructions before fueling. Keep the fuel and fuel tank clean. Avoid filling the machine with dirty fuel. Make sure the fuel cap is properly tightened and the gasket is not damaged, particularly before washing the machine.

Use unleaded gasoline with minimum 86 octane rating. Never use gasoline mixed with two-cycle oil. For ethanol and methanol fuel, the following applies:

Maximum allowable ethanol 10% (volume).

Maximum allowable methanol 5% (volume).

Maximum allowable MTBE (Methyl Tertiary Butyl Ether) 15% (volume).

The engine can be damaged if it knocks or pings at normal load. Drain the fuel tank and replace with fresh fuel. If this does not help, contact an authorized service workshop.

Do not fill the tank completely; leave space for the fuel to expand as it warms up.

Cutting Unit

Depth Lever

Use the depth lever to raise and lower the blades between working and transport position. The depth lever has a lock-out bolt that should be left in until the blades wear down. Then move the bolt to a lower hole to allow the blades to penetrate the soil.

- **Flail Blades or Spring Tines** Set blade or tine depth so that the blades or tines just touch on a flat surface such as a sidewalk or driveway.
- **Delta Blades** Set blades to penetrate the soil to a depth of $\frac{1}{8}$ " to $\frac{1}{4}$ " with a maximum penetration of $\frac{1}{2}$ ". Check seed bag for the manufacturer's recommended depth of application
- Lawns with deep thatch exceeding $\frac{3}{4}$ " may be best dethatched in two treatments (spring and fall) to avoid major shock to an older lawn.

Clutch

The clutch tightens the drive belt and engages the drive for the blades. When the clutch lever is pressed against the handle, the blades begin to rotate. Hold the clutch tightly when working so the belt does not slip.

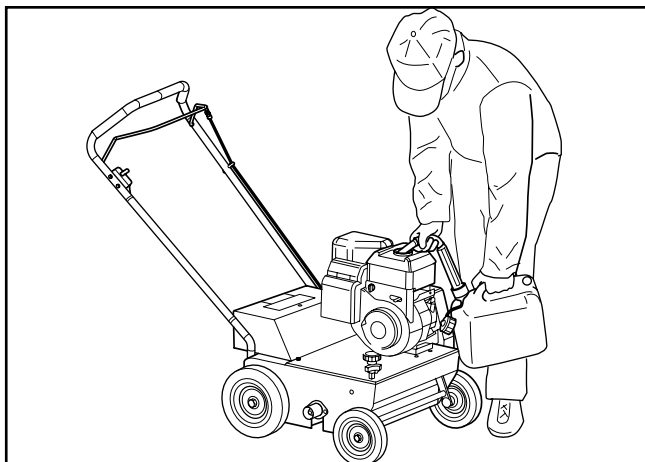

8011-019

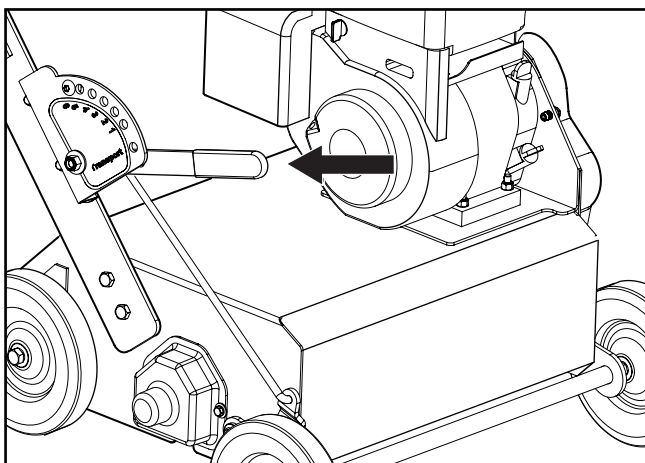

8064-017

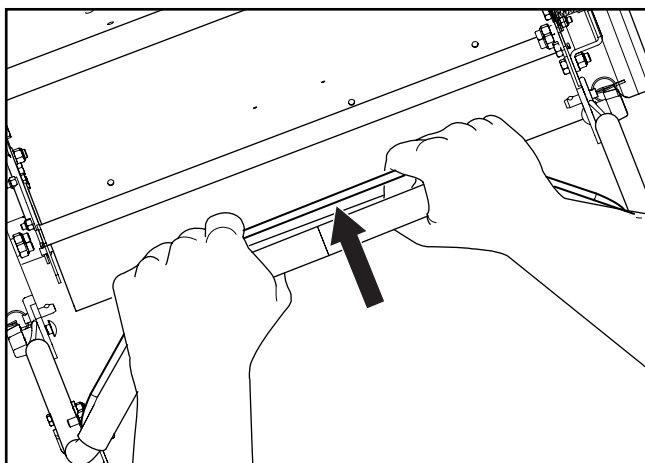

8064-018

CONTROLS

Blade versatility

Flail Blades

Thatch is the dense layer of clippings, roots and stems that forms between the soil and the base of the grass. As thatch builds up, it prevents water, air and fertilizer from being absorbed into the soil. This causes shallow root development leading to vulnerability to drought and frost. Excessive thatch also creates an ideal environment for insects and lawn diseases. Power-raking with flail blades removes this thatch layer and restores your lawn to good health. Flail blades offer the most aggressive dethatching of all the blades offered.

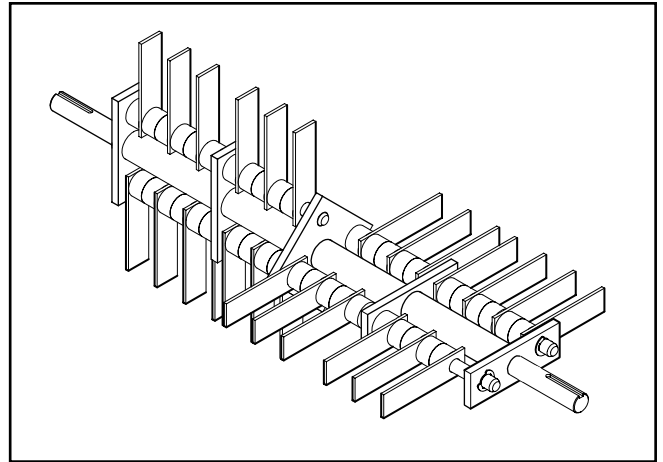

8060-048

Delta Blades

Delta blades were created primarily for overseeding existing lawn. They effectively incorporate grass seed into the soil. This is an easy, reliable method for rejuvenating poor lawns. The delta blade is also useful as a vertical mower for cutting running stem grasses and opening up the soil to oxygen, water, nutrients and other chemicals. Delta blades are also beneficial on slopes, terraces and in high clay content soils where water runoff is a problem. The blades should be set to penetrate the soil to a depth of $\frac{1}{8}$ " to $\frac{1}{4}$ " with a maximum penetration of $\frac{1}{2}$ ".

Check your seed bag for the manufacturer's recommended depth of application.

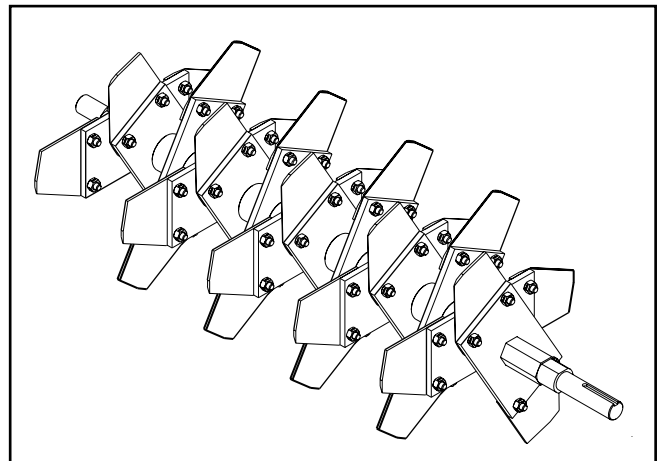

8064-019

Spring Tines

Ideal for the established lawn that is not in need of a complete renovation but requires dethatching (dry-spots, fungus, etc.). Spring tines are designed to pluck dead grass and thatch out of the lawn without tearing or damaging existing root structure. With the flexible tines, the lawn is combed only 0.5 cm into the soil, so it cannot penetrate the root structure. Spring tines provide less aggressive dethatching than flail blades. **NOTE: Do not use spring tines with bagger attachment.**

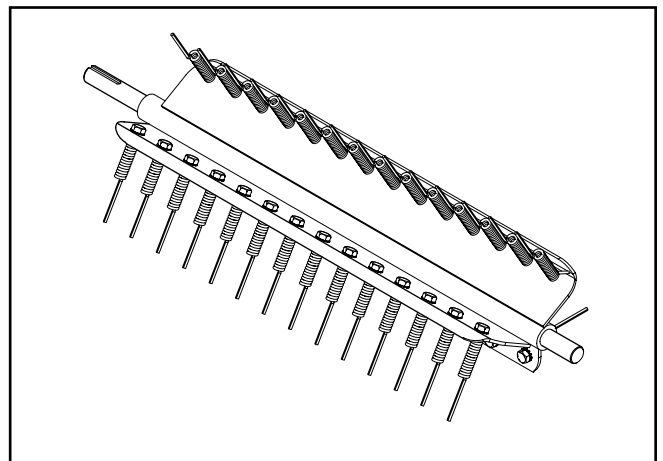

8064-020

OPERATION

Before Starting

- Mow the lawn ½" shorter than normal.
- Allow the lawn to dry. Wet conditions can cause extensive damage to healthy grass.
- Check for stones or fixed objects in the lawn.

IMPORTANT INFORMATION

**Clear the lawn of any debris.
Clearly mark rocks and other fixed objects.
Be especially sure to check for hidden
electrical cables or similar in the surface of the
lawn.**

Dethatching

- Set the depth lever in working position.

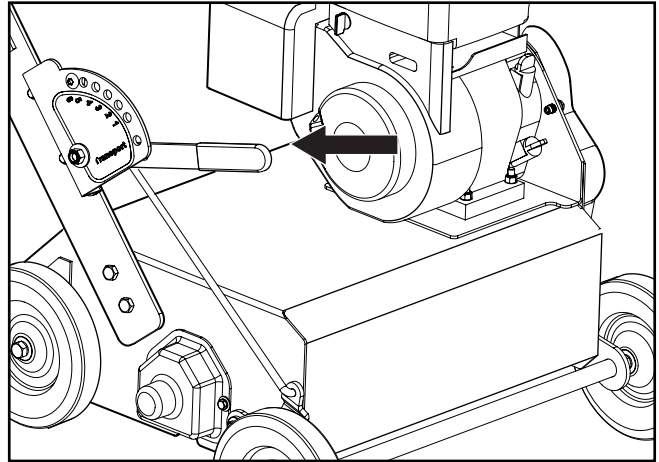

8064-017

- To engage the clutch in heavy thatch, bear down on the handle and raise the front wheels slightly. Hold the clutch engaged against the handle and carefully lower the machine into the turf.
- Do a small test area at a slow walking pace.
- If the engine speed drops excessively, the depth setting is too deep. If the machine pulls forward and bucks roughly, the depth setting is too deep.

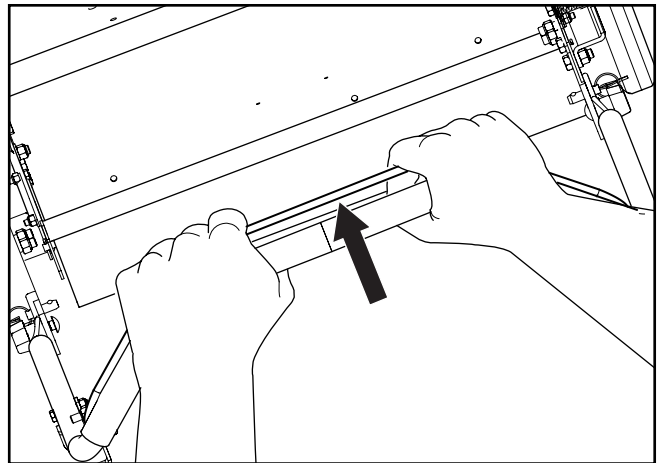

8064-018

Hold clutch bail against handle

Finishing

- Remove all extracted thatch from the grass and compost/dispose of properly.
- Other methods for improving your lawn may include aeration and fertilization.

OPERATION

Seed Application

Preparing the Lawn

- Cut the grass to approximately 1/2" (1-1.5 cm) lower than you normally would.
- Do not water before sowing.
- Remove the layer of old grass cuttings (thatch).
- Aerate the lawn with a core-type ground aerator.
- Fertilize the lawn.

Seed Application Chart

Located on the seeder, the chart values are approximate; quantities of seed depend on the speed at which the machine is run. Faster running speeds results in sparser sowing.

To set the seed application, loosen the wingnut and turn the seeder dial to the desired sowing setting. Retighten wingnut.

Pull back on the OPEN/CLOSE lever to apply seed.

Seed Application Recommendations

- For best results, sow in two directions with a 45° angle between.
- Water generously immediately afterward and continue watering moderately for 10–14 days to keep the soil moist.
- After germination, water sporadically to encourage root growth.

Bagger Attachment and Removal

To attach bagger, step on the safety door rear bolt and push down until door is flat. Set the bagger onto the door and up against the chute.

Secure bag clamp.

To remove bag, unlatch bag clamp. Push down on rear bolt and slide bagger away from the chute. The safety door is spring loaded and will flip up to cover the rear opening until the bag is reinstalled.

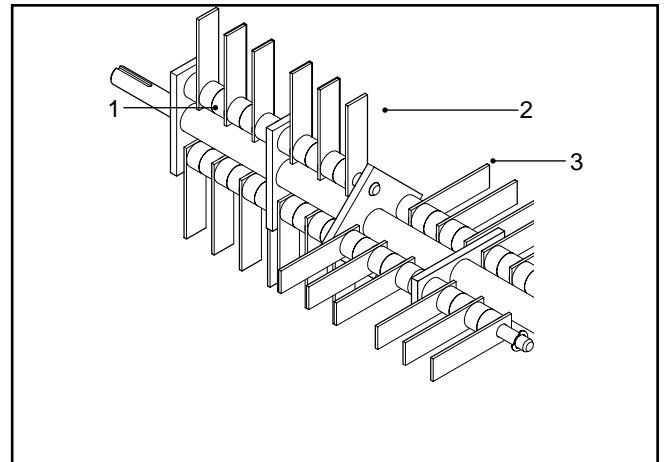

8060-021

1. Selection dial
2. Wingnut
3. OPEN/CLOSE lever

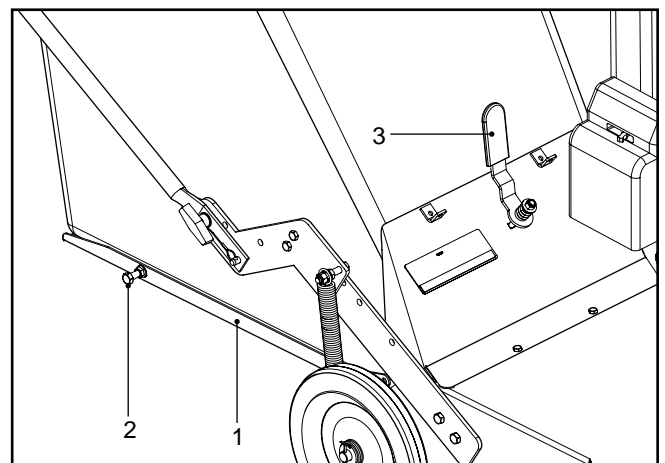

8060-023

1. Safety door
2. Rear nut
3. Bag clamp

MAINTENANCE

Maintenance Schedule

The following is a list of maintenance procedures that must be performed on the machine. **For those points not described in this manual, visit an authorized service workshop.**

MAINTENANCE	Daily Before Starting	Maintenance interval - months/hours			
		1/25	3/50	6/100	12/300
Check the engine oil level	●				
Replace engine oil ¹⁾				●	
Check the air filter	●				
Replace air filter cartridge ²⁾			●		
Clean sludge reservoir for fuel system				●	
Check and clean the spark plug				●	
Replace spark plug					●
Check idle speed					●
Check and adjust play in valves ³⁾					●
Clean fuel tank ³⁾					●
Check, replace fuel lines as necessary ^{3, 4)}					●
Check clutch and clutch cable	●				
Check flail blade lock washers	●				
Check decals and warning signs	●				
Check the seed holes for the seeder	●				
Check wear and tension on the belts		●			
Check blade wear and condition		●			
Check the chassis, bolts and set screws			●		
Check the seed control lever for the seeder		●			
Check the wire mountings on the seeder		●			
Lubrication; see the Lubrication schedule					

¹⁾ First change after 20 hours. ²⁾ In dusty conditions maintenance is required at shorter intervals. ³⁾ Performed by authorized service workshop.

⁴⁾ Performed every second year.

With daily use, the machine shall be lubricated twice weekly.



WARNING!

No service operations may be performed on the engine or unit unless:
The engine is stopped.
The ignition cable has been removed from the spark plug.
The machine is securely parked where it will not tip or begin rolling.

MAINTENANCE

Drive Belt

1. When checking the drive belt, allow the engine to cool.
2. Remove the spark plug cable.
3. Remove the belt guard (see illustration) on the left side of the machine.
4. Check that the belt is running in the proper track; the pulleys should guide the belt in a straight line.
5. Check that the belt and pulleys are not oily. If they are, first try to clean them with spirits. If they are heavily coated, take the machine to an authorized service workshop to fix the oil leakage and replace the belt.
6. Check the belt for cracks, heat damage or worn edges.
7. Check that guide and tensioning equipment for the belt is properly set and not loose.
8. If the belt needs to be replaced—loosen the belt guides.
9. Remove the old belt.
10. Check for wear on the pulleys and replace as necessary.
11. Check the engine pulley alignment to the rotor pulley and adjust as necessary. The belt should run straight.
12. Fit a new belt by first pulling it over the lower pulley and then the engine pulley. Check that the tensioning pulley and belt guides end up outside the belt loop.
13. Tighten belt guides and refit the belt guard.

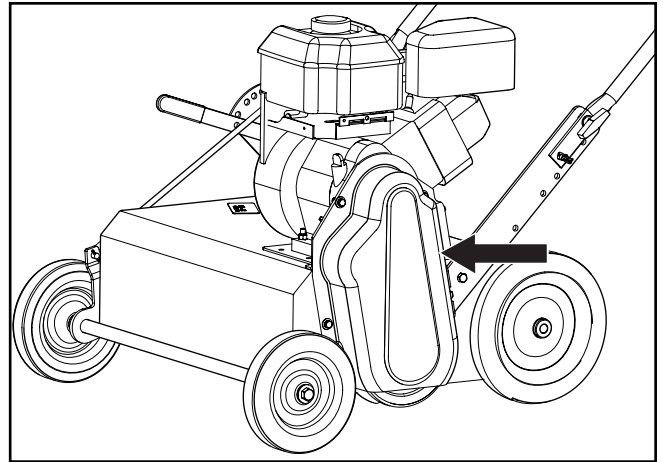

8064-021

Remove belt cover

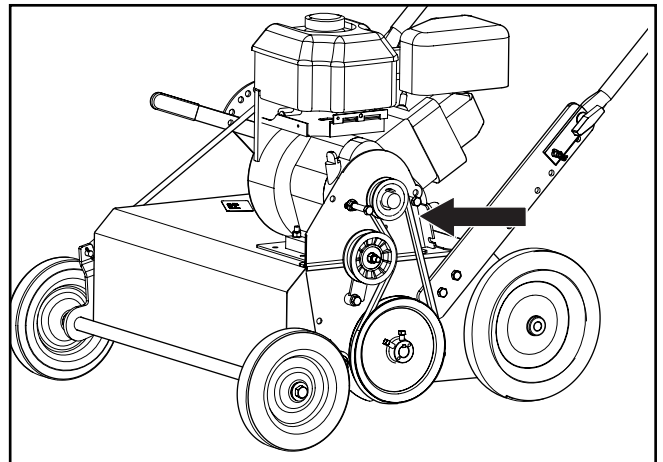

8064-022

Check drive belt

Cleaning and Washing

Regular cleaning and washing will increase the machine's lifespan. Make it a habit to clean the machine directly after use, before the dirt sticks.

Check before rinsing that the fuel tank lid is properly in place to avoid getting water in the tank.

Use caution when using high-pressure spray because warning decals, instruction signs and the engine can be damaged. **Do not exceed 70 bar/1000 PSI water pressure when cleaning.**

Lubricate the machine after cleaning. This is particularly important if the machine is to be stored.

MAINTENANCE

Flail blades

IMPORTANT INFORMATION

Only the flail blade rotor shaft can be rotated to achieve even wear. The spring tines and delta blades must be operated in the correct direction.

Rotating blades

After using the dethatcher for some time, the blades will begin to wear on the striking edge and dethatching performance will diminishes. A new combing edge may be obtained by rotating the entire rotor shaft assembly laterally (end to end). This procedure can be repeated until the blades reach their wear limit; see illustration.

To rotate the rotor shaft:

1. Allow the engine to cool.
2. Disconnect the spark plug.
3. Remove the belt and shaft guards.
4. Remove the drive belt.
5. Loosen the set screws on the lower belt pulley and remove the pulley from the rotor shaft.
6. Remove the hardware and bearings from each side of the dethatcher housing.
7. Allow the rotor shaft to slide out.
8. Check the shaft, bearing, blade length, blade e-rings and spacers.
9. Rotate the shaft end for end.
10. Refit the bearings and secure.
11. Refit the lower pulley, aligning it with the top pulley.
12. Reinstall the drive belt.
13. Check the pulley alignment to the engine shaft pulley. The drive belt should run smoothly in its track. Adjust as necessary. Tighten pulleys.
14. Replace the belt and shaft guards and tighten securely.
15. Reattach the spark plug cable.

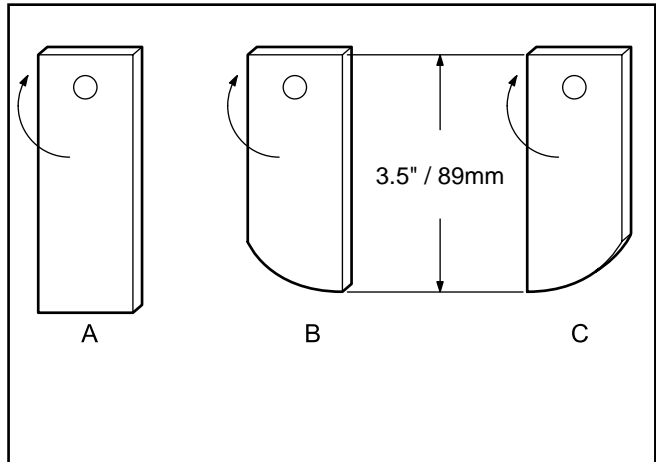

8011-006

- A. New blade
- B. Worn blade
- C. After rotation

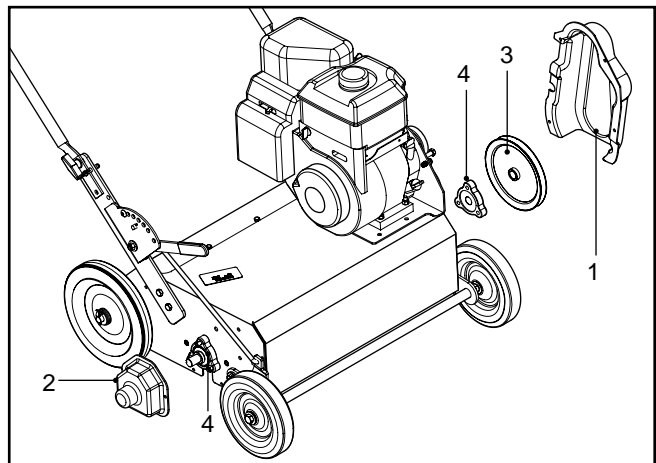

8064-023

- 1. Belt guard
- 2. Shaft guard
- 3. Lower belt pulley
- 4. Flange bearings

Checking rotor shaft for wear

MAINTENANCE

Replacing flail blades

1. Allow the engine to cool.
2. Disconnect the spark plug.
3. Tip the machine forward; see *Two Minute Rule* in this section.
4. Remove e-rings (1) holding the blade shaft (2) in place (see the illustration).
5. Inspect the blade shafts and replace if bent or worn.
6. Drive the blade shafts out towards the center. The blades (4) and the plastic spacers (3) will fall off.
7. Fit the new blades and replace the plastic spacers as necessary. Refer to the illustration of the components for blade/spacer placement.
8. Reinstall e-rings.
9. Repeat the procedure for the remaining blade shafts.
10. Reattach the spark plug cable.

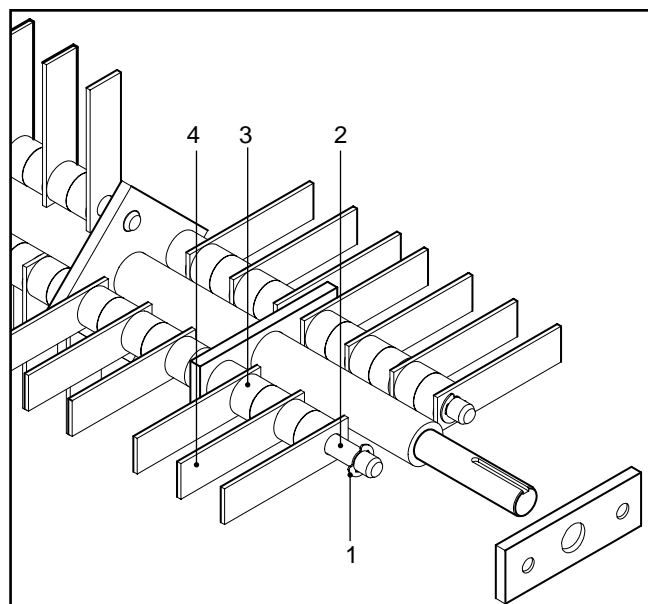

8060-020

1. E-ring
2. Blade shaft
3. Spacer
4. Blade

IMPORTANT INFORMATION

When tipping the machine forward observe the *Two Minute Rule*.

Two Minute Rule

The machine may be tipped forward to access the underside for cleaning or service, but **no longer than 2 minutes**.

If the machine remains tipped for longer periods, the engine may be damaged by gasoline draining into the crankcase.

If the machine has been tipped longer than the approved time limit, perform an extra oil change on the engine. Remove the spark plug and turn the engine over a few revolutions with the starter handle before starting the engine again.

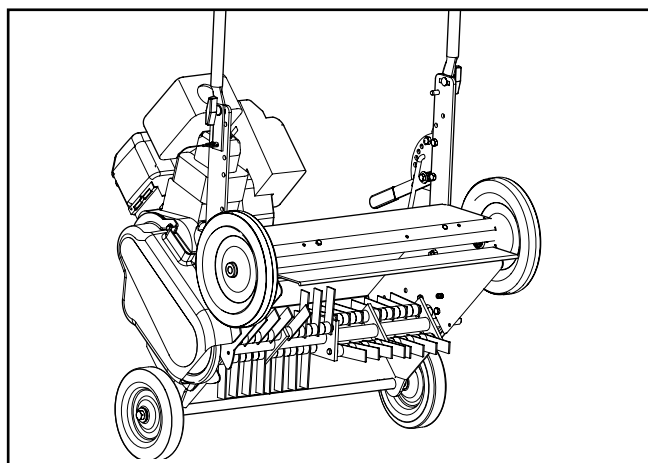

8064-024

MAINTENANCE

Delta Blades

Replacing delta blades

Over time and due to wear, the blades will delta diminish in length. Once the blades have worn down by about $\frac{3}{4}$ " (19 mm), the overall length of the blade at the longest point of the blade will be about $2\frac{1}{2}$ " (64 mm), and it will be necessary to replace the blades.

It is possible to replace delta blades without removing the rotor shaft. Remove the delta blade by removing the two screws with nuts holding the blade in place.

Turn the new blade until it is properly aligned; see illustration.

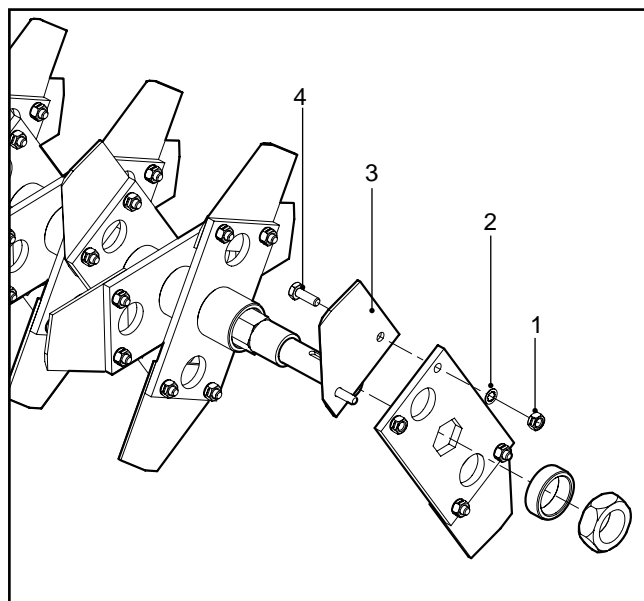

8060-049

1. Nut
2. Washer
3. Delta blade
4. Screw

Spring tines

Wear/Replacing

Over time and due to wear, the tines will diminish in length. When the tines can no longer be adjusted to comb $\frac{1}{4}$ " (6 mm) into the soil, the tines must be replaced.

Spring tines can be replaced without removing the rotor shaft by using a $\frac{1}{2}$ " socket wrench. Remove the screw, star washer and worn spring.

Replace the spring tine using the wrench.

IMPORTANT INFORMATION
Do not use spring tines with bagger attachment.

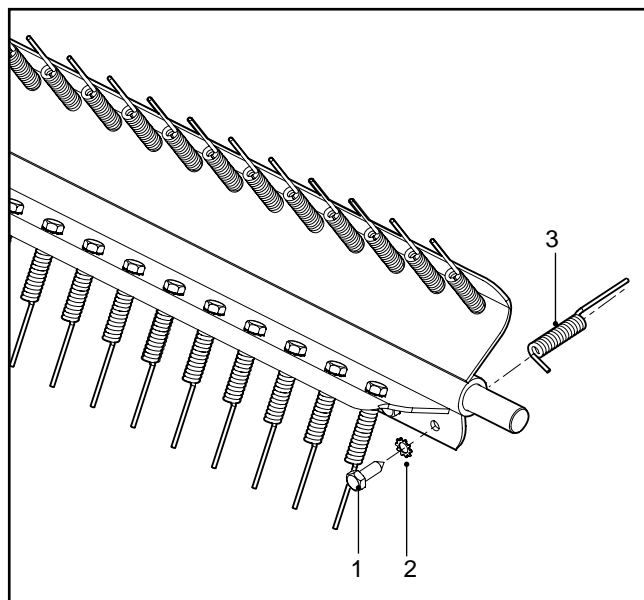

8060-050

1. Screw
2. Star washer
3. Spring tine

LUBRICATION

Stop the engine and remove the ignition cable before attempting to lubricate the machine.

Wipe away excessive grease after lubrication. It is important to avoid getting lubricant on the belt or the drive surfaces on the belt pulleys. Should this happen, attempt to clean them with spirits. If the belt continues to slip after cleaning, it must be replaced.

Lubrication Schedule

1. Check engine oil daily, change every six months or 100 hours.
2. Check and lubricate wheel bearings once a month.
3. Lubricate folding handle points once a week. Lubricate the joints at both sides of the handle with an oil can.
4. Lubricate main shaft bearings once a week or every 40 hours.
5. Cover the blades with a thin coat of oil to avoid rust. This is particularly important prior to winter storage or if the machine will not be used for a period of longer than 30 days.

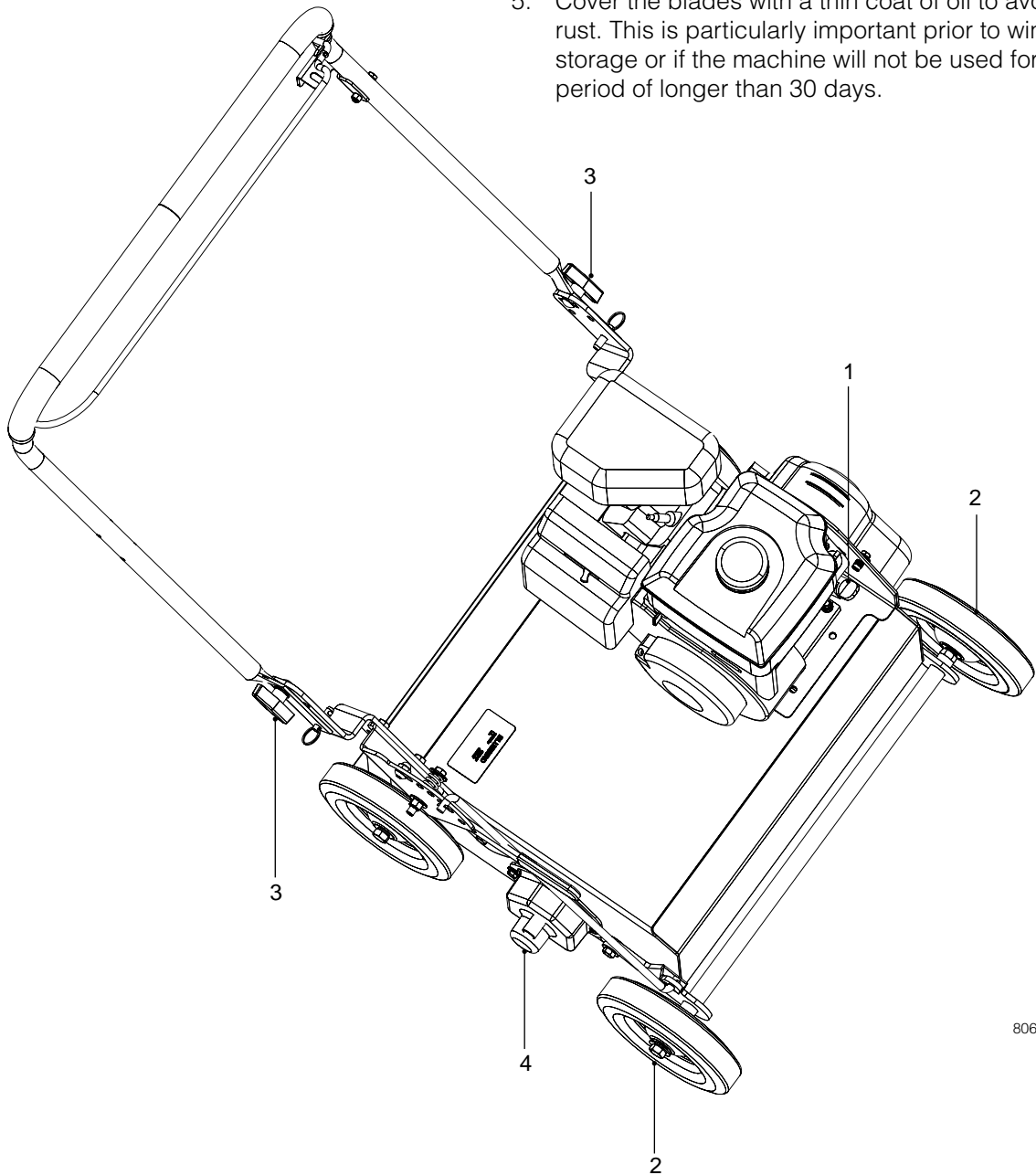

8064-025

CONFORMITY CERTIFICATES

USA Requirements

Labels are placed on the engine and/or in the engine compartment stating that the machine will fulfill the requirements. This is also applicable to special requirements for any of the states, (California emission rules etc.). Do not remove any of these labels. Certificates can also be supplied with the machine at delivery or written in the Engine manual. Take care of them as they are valuable documents.

CE Requirements

The Declaration of Conformity is included as an addendum to the operators instructions.

Dethatcher

Machine complies with:

2006/42/EC

2004/108/EC

2000/14/EC

Business Name & Address:

Husqvarna Turf Care
401 North Commerce
Beatrice, NE 68310 USA

Notified Body:

TUV SUD Industrie Service GmbH
Westendstrasse 199
D-80686 Muenchen

TROUBLESHOOTING

Symptom	Cause	Action
Engine will not start		
User error	Fuel valve closed.	Open the fuel valve.
	Choke valve open	Close the choke with cold engine.
	Engine switch in OFF position	Turn the engine switch to ON
Fuel system	Fuel tank empty	Fill with fuel
	Machine stored without observing proper procedure from chapter "Storage/Winter storage"	Clean tank, sludge reservoir and empty carburetor. Fill the tank with fresh fuel.
	Contamination, water or ice in fuel system.	Clean tank, sludge reservoir and empty carburetor. Fill the tank with fresh fuel.
	Carburetor problems.	Contact an authorized service workshop.
Spark plug	Wrong spark plug type.	Replace the spark plug.
	Build-up on electrodes. Short circuit.	Check electrode gap and clean or replace spark plug.
	Gasoline or oil on the spark plug.	Clean the spark plug. Air the engine out. Start with full throttle.
No spark after checking spark plug	Faulty engine switch, cable or ignition.	Contact an authorized service workshop.
Low compression	Serious interior engine damage or faulty valves.	Contact an authorized service workshop.
Engine is under-powered or runs unevenly		
Air filter	Clogged air filter	Clean or replace the air filter
Fuel system	Machine stored without observing proper procedure from chapter "Storage/Winter storage"	Clean tank, sludge reservoir and empty carburetor. Fill the tank with fresh fuel.
Blue or voluminous blue-white exhaust	Contaminated or incorrect fuel	Clean tank, sludge reservoir and empty carburetor. Fill the tank with proper fuel.
Black exhaust	Choke left on	Open choke valve
	Clogged air filter	Clean or replace the air filter
	Carburetor problems	Contact an authorized service workshop.
Ignition system	Wrong spark plug type	Replace the spark plug
	Build-up on electrodes. Short circuit.	Check electrode gap and clean or replace spark plug.
	Faulty ignition unit.	Contact an authorized service workshop.
Low compression	Serious interior engine damage or faulty valves.	Contact an authorized service workshop.

STORAGE

Winter storage

At the end of the season, the machine should be readied for storage (or if it will not be in use for longer than 30 days). Fuel allowed to stand for long periods of time (30 days or more) can leave sticky residues that can plug the carburetor and disrupt engine function.

Fuel stabilizers are an acceptable option to reducing sticky residues during storage. If alkylate gasoline (Aspen) is used, stabilizers are unnecessary because this fuel is stable. However, you should avoid switching between regular and alkylate gasoline as sensitive rubber components can harden. Add stabilizer to the fuel in the tank or in the storage container. Always use the mixing ratios specified by the manufacturer of the stabilizer. Run the engine for at least 10 minutes after adding the stabilizer so that it reaches the carburetor. Do not empty the fuel tank and the carburetor if you have added stabilizer.

To ready the machine for storage, follow these steps:

1. Clean the machine carefully, particularly the chassis and working equipment. Mend damage to the paint to prevent rust.
2. Inspect the machine for worn or damaged parts and tighten any nuts or bolts that may have become loose.
3. Change the engine oil; dispose of properly.
4. Open the fuel valve. Empty the fuel tank and the carburetor.
5. Close the fuel valve.
6. Remove the spark plug and pour about a tablespoon of engine oil in the cylinder. Turn over the engine so that the oil is evenly distributed and then refit the spark plug.
7. Lubricate all grease nipples, joints and shafts as described in the section *Lubrication*.
8. Store the machine in a clean, dry place and cover for extra protection.

Service

When ordering spare parts, please specify the purchase year, model, type, and serial number.

Always use genuine Husqvarna spare parts.

An annual check-up at an authorized service workshop is a good way to ensure that your machine performs its best the following season.



WARNING!

Never store an engine with fuel in the tank indoors or in poorly ventilated spaces where fuel vapor can come in contact with open flame, sparks or a pilot light such as in a boiler, hot water tank, clothing drier, etc. Handle the fuel with caution. It is very flammable and careless use can cause serious damage to person and property. Drain the fuel into an approved container outdoors and far away from open flame. Never use gasoline for cleaning. Use a degreaser and warm water instead.

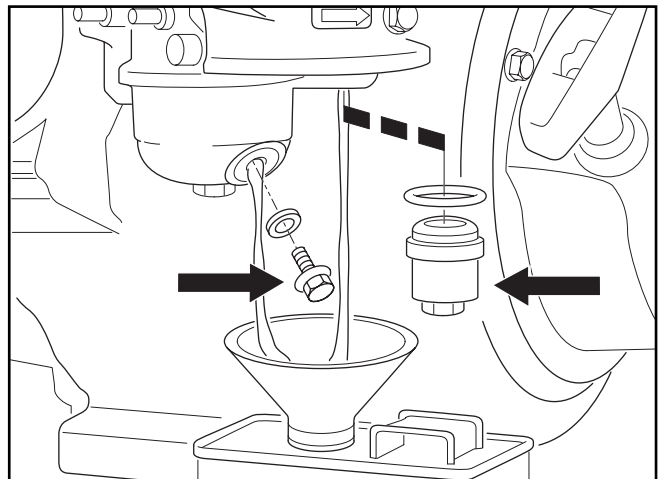

8011-130

Fuel tank plug and filter

TECHNICAL DATA

22" DETHATCHER																										
Engine	Honda																									
Primary drive	V-belt																									
Dethatching width	22"																									
Clutch control	Handle-mounted with automatic safety declutching																									
Clutch	Belt tightener with spring return and idling pulley mechanism																									
Depth setting	Adjustable depth control with lever mechanism																									
Handle	Folding, ergonomic design with soft grip																									
Accessories																										
Seed hopper	1368 in ³ (22.3 L) or approx. 30 lbs (13.6 kg) seed, self-propelled stirring, inspection window																									
Seeding Width	22" (55.8 cm)																									
Flail blade reel	32 case-hardened steel blades with ⁵ / ₈ " (1.6 cm) spacers ¹ / ₈ " x 1" x 3 ¹ / ₂ " (0.3 x 2.5 x 8.9 cm)																									
Delta blade reel	30 austempered 12-gauge steel blades with 2" (5 cm) spacers																									
Catcher Bag	8 ft ³ (0.23 m ³) synthetic material on frame with wheels																									
Weights																										
Dethatcher	144 lbs (65.3 kg)																									
with seed hopper	165 lbs (74.8 kg)																									
with catcher bag	157 lbs (71.2 kg)																									
Width	28" (71 cm)																									
Length	26 ³ / ₄ " (68 cm) without handle 50" (127 cm) with handle																									
Height	24" (61 cm) without handle 40" (102 cm) with handle																									
Distance between axles	17 ³ / ₄ " (45cm) center to center																									
Bearings	³ / ₄ " closed flanged cartridge																									
Wheels	Front 8" x 1 ³ / ₄ " Back 10" x 2 ³ / ₄ " catcher bag Back 10" x 1 ³ / ₄ " seed hopper																									
Vibration	<table border="1" style="width: 100%; border-collapse: collapse;"> <thead> <tr> <th style="width: 20%;">Flail Shaft</th> <th style="width: 20%;">Spring Tine</th> <th style="width: 20%;">Delta</th> <th style="width: 20%;">Seeder</th> <th style="width: 20%;">Bagger</th> </tr> </thead> <tbody> <tr> <td colspan="5" style="text-align: center;">Daily Exposure</td> </tr> <tr> <td style="text-align: center;">4.24 m/s²</td> <td style="text-align: center;">6.5 m/s²</td> <td style="text-align: center;">3.98 m/s²</td> <td style="text-align: center;">9.96 m/s²</td> <td style="text-align: center;">7.88 m/s²</td> </tr> <tr> <td colspan="5" style="text-align: center;">Equivalent Vibration</td> </tr> <tr> <td style="text-align: center;">4.9 m/s²</td> <td style="text-align: center;">7.5 m/s²</td> <td style="text-align: center;">4.6 m/s²</td> <td style="text-align: center;">11.5 m/s²</td> <td style="text-align: center;">9.1 m/s²</td> </tr> </tbody> </table>	Flail Shaft	Spring Tine	Delta	Seeder	Bagger	Daily Exposure					4.24 m/s ²	6.5 m/s ²	3.98 m/s ²	9.96 m/s ²	7.88 m/s ²	Equivalent Vibration					4.9 m/s ²	7.5 m/s ²	4.6 m/s ²	11.5 m/s ²	9.1 m/s ²
Flail Shaft	Spring Tine	Delta	Seeder	Bagger																						
Daily Exposure																										
4.24 m/s ²	6.5 m/s ²	3.98 m/s ²	9.96 m/s ²	7.88 m/s ²																						
Equivalent Vibration																										
4.9 m/s ²	7.5 m/s ²	4.6 m/s ²	11.5 m/s ²	9.1 m/s ²																						
Standard Deviation	0.9 m/s ²																									
Sound																										
Operator Ear	89 dB(A)																									
Guaranteed Value	102 dB(A)																									
Measured Value	101 dB(A)																									

SERVICE JOURNAL

Action

Date, stamp, signature

Delivery Service

Break the packaging and make sure the machine has not been damaged in transport.	<input type="checkbox"/>
Where applicable, assemble accompanying components.	<input type="checkbox"/>
Check that the machine design corresponds to the customer order.	<input type="checkbox"/>
Check that the right amount of oil is in the engine and transmission.	<input type="checkbox"/>
Check that the working equipment is properly set.	<input type="checkbox"/>
Check that the drive pulleys are aligned.	<input type="checkbox"/>
Check that belts are properly adjusted.	<input type="checkbox"/>
Lubricate the machine as described in the lubrication schedule.	<input type="checkbox"/>
Fill the fuel tank and start the engine.	<input type="checkbox"/>
Check all operating instruments.	<input type="checkbox"/>
Check decals and information attached to the unit.	<input type="checkbox"/>
Check the engine speed (RPM), see Technical Data.	<input type="checkbox"/>
Check for leakage.	
Inform the customer about:	
The need and advantages of following the service schedule.	<input type="checkbox"/>
The need and advantages of leaving the machine for service every 300 hours.	<input type="checkbox"/>
The effects of service and maintaining a service journal on the machine's resale value.	<input type="checkbox"/>
Application areas for Mulching.	<input type="checkbox"/>
Fill in the sales papers, etc.	<input type="checkbox"/>
	Delivery service has been carried out.
	No remaining notes.
	Certified:

After the first 20 hours

Change engine oil.	<input type="checkbox"/>
Check that belts are properly adjusted.	<input type="checkbox"/>
Tighten screws and nuts.	<input type="checkbox"/>

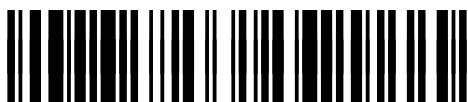

Original instructions
115 26 74-26

2010-03-01