

ILLUSTRATED PARTS LIST

MODEL NUMBER 12527HV

PRODUCT NUMBER 961 93 00-71

MFG. ID. NUMBER 96193007100

REPAIR PARTS

AUGER HOUSING / IMPELLER ASSEMBLY

SNOW THROWER - MODEL NO. **12527HV** (96193007100), PRODUCT NO. 961 93 00-71

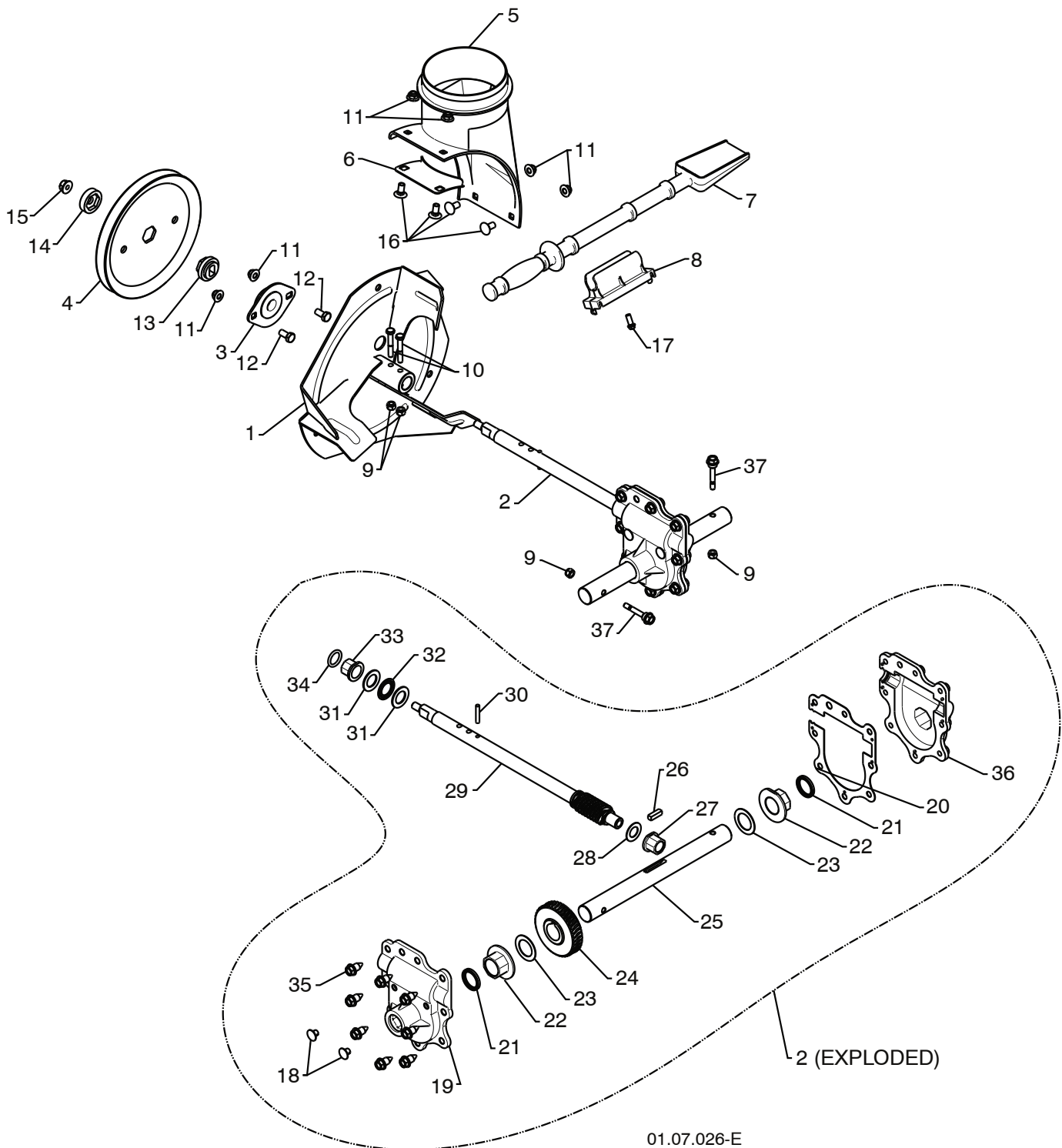

01.07.026-E

NOTE: All component dimensions given in U.S. inches. 1 inch = 25.4 mm
IMPORTANT: Use only Original Equipment Manufacturer (O.E.M.) replacement parts.
Failure to do so could be hazardous, damage your snow thrower and void your warranty.

REPAIR PARTS

AUGER HOUSING / IMPELLER ASSEMBLY

SNOW THROWER - MODEL NO. **12527HV** (96193007100), PRODUCT NO. 961 93 00-71

KEY NO.	PART NO.	DESCRIPTION
1	532 18 41-05	IMPELLER
2	532 42 71-48	GEARBOX ASSEMBLY
3	532 18 89-09	BEARING
4	532 42 71-46	IMPELLER PULLEY
5	532 44 24-38	DISCHARGE BASE
6	532 18 40-95	CORNER BRACKET
7	532 19 21-99	CLEAN OUT TOOL
8	532 40 54-00	TOOL CLIP
9	873 80 04-00	NUT 1/4-20
10	874 78 04-26	SCREW 1/4-20 X .625
11	532 42 79-42	NUT 5/16-18
12	532 16 31-83	SCREW 5/16-18 X .625
13	532 42 71-45	IMPELLER HUB
14	532 42 71-54	IMPELLER SLEEVE
15	873 90 06-00	NUT 3/8-16
16	532 18 03-55	CARRIAGE BOLT
17	532 19 41-89	SCREW 13-16 X .625
18	532 40 77-60	PLUG
19	532 42 73-02	GEARBOX COVER RH
20	532 42 73-45	GASKET
21	532 40 77-70	SEAL
22	532 40 77-62	BEARING
23	532 17 46-97	THRUST WASHER 1.00
24	532 40 77-63	WORM GEAR
25	532 40 77-64	AUGER SHAFT
26	532 18 92-82	SQUARE KEY
27	532 40 77-58	BEARING
28	532 17 46-83	THRUST WASHER
29	532 42 71-47	IMPELLER SHAFT
30	532 18 42-05	ROLL PIN
31	532 17 46-81	THRUST WASHER
32	532 17 46-84	THRUST BEARING
33	532 40 77-69	BEARING
34	532 40 77-68	O-RING
35	532 40 77-67	SCREW 5/16-18 X .750
36	532 42 73-17	GEARBOX COVER LH
37	532 19 20-90	SHEAR BOLT

NOTE: All component dimensions given in U.S. inches. 1 inch = 25.4 mm

IMPORTANT: Use only Original Equipment Manufacturer (O.E.M.) replacement parts. Failure to do so could be hazardous, damage your snow thrower and void your warranty.

REPAIR PARTS

AUGER HOUSING / IMPELLER ASSEMBLY

SNOW THROWER - MODEL NO. **12527HV** (96193007100), PRODUCT NO. 961 93 00-71

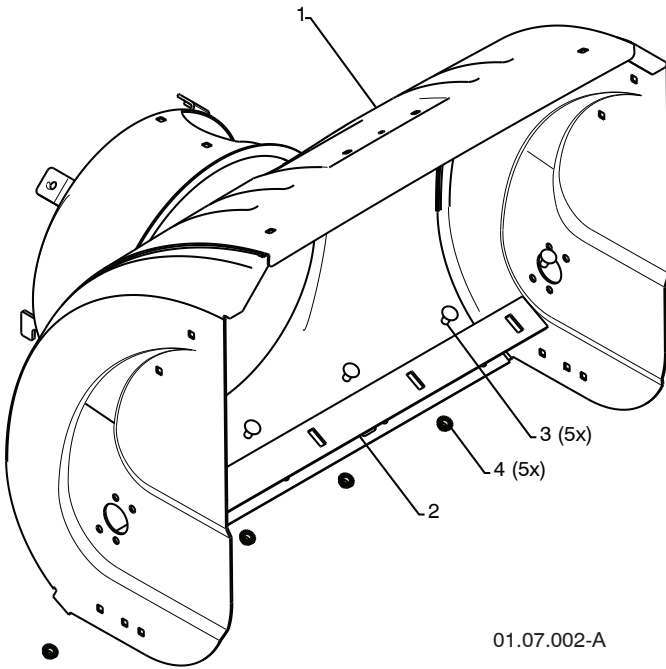

KEY NO.	PART NO.	DESCRIPTION
1	532 40 77-39	AUGER HOUSING 27
2	532 40 77-27	SCRAPER BAR
3	872 27 05-05	CARRIAGE BOLT 5/16-18 X .625
4	532 15 53-77	NUT 5/16-18

01.07.002-A

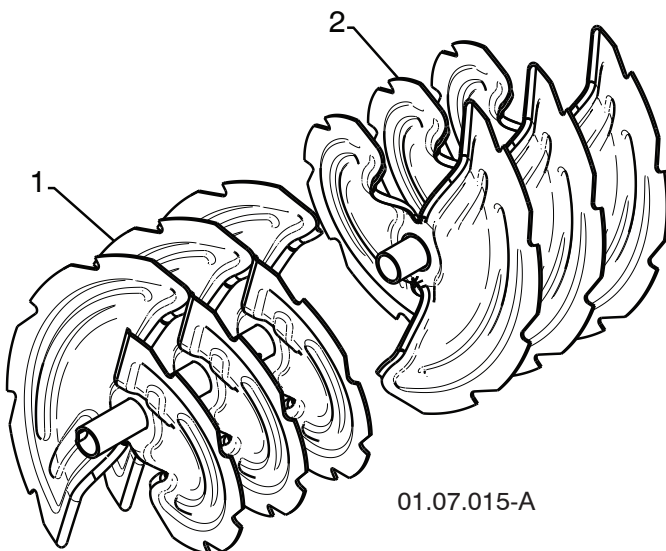

KEY NO.	PART NO.	DESCRIPTION
1	532 42 24-42	AUGER ASSEMBLY 27 LH
2	532 42 21-43	AUGER ASSEMBLY 27 RH

01.07.015-A

NOTE: All component dimensions given in U.S. inches. 1 inch = 25.4 mm
IMPORTANT: Use only Original Equipment Manufacturer (O.E.M.) replacement parts.
Failure to do so could be hazardous, damage your snow thrower and void your warranty.

REPAIR PARTS

AUGER HOUSING / IMPELLER ASSEMBLY

SNOW THROWER - MODEL NO. 12527HV (96193007100), PRODUCT NO. 961 93 00-71

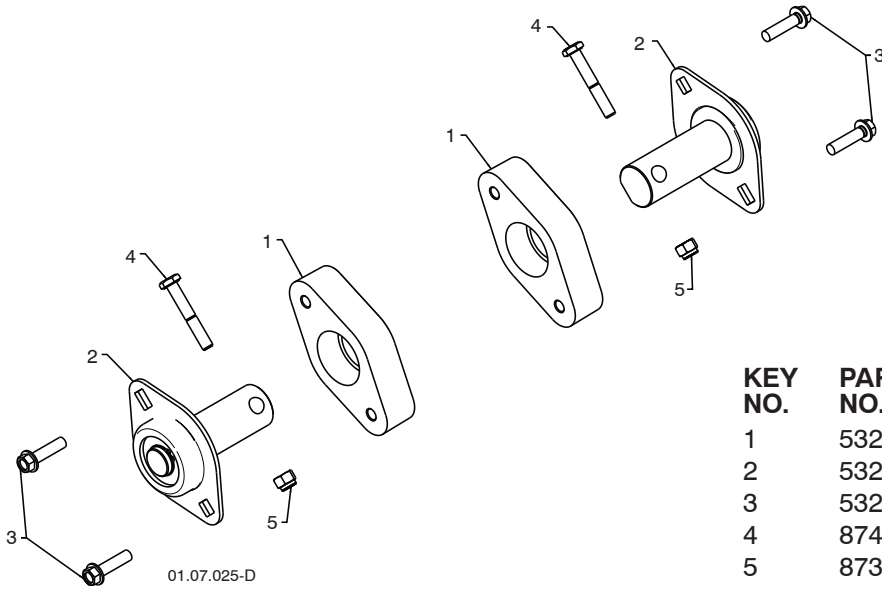

01.07.025-D

KEY NO.	PART NO.	DESCRIPTION
1	532 18 81-70	PLASTIC RETAINER
2	532 43 06-91	AUGER BALL BEARING
3	532 17 95-82	SCREW 5/16-18 X 1.00
4	874 78 04-26	SCREW 1/4-20 X .625
5	873 80 04-00	NUT 1/4-20

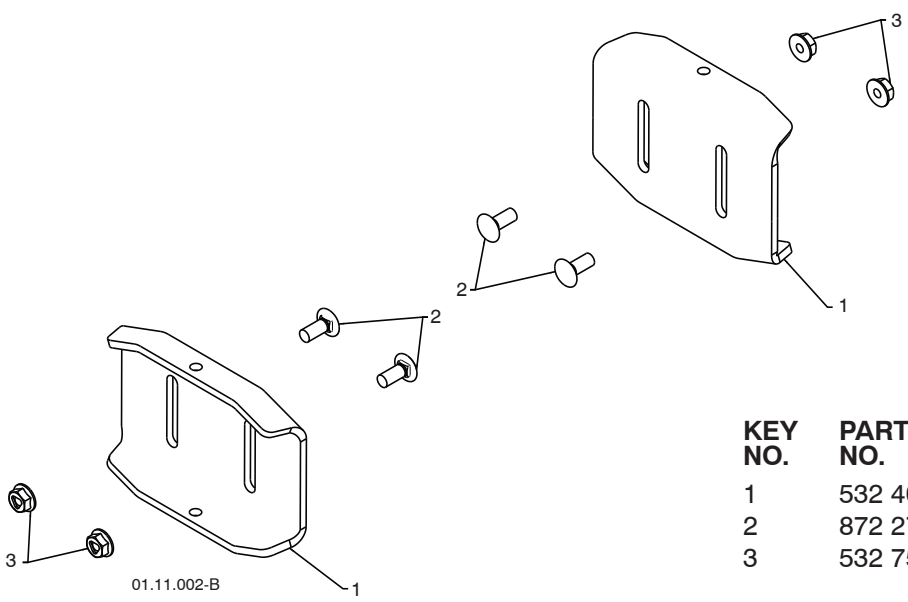

01.11.002-B

KEY NO.	PART NO.	DESCRIPTION
1	532 40 78-34	SKID PLATE
2	872 27 05-06	CARRIAGE BOLT 5/16-18 X .750
3	532 75 11-53	NUT 5/16-18

NOTE: All component dimensions given in U.S. inches. 1 inch = 25.4 mm
IMPORTANT: Use only Original Equipment Manufacturer (O.E.M.) replacement parts.
 Failure to do so could be hazardous, damage your snow thrower and void your warranty.

REPAIR PARTS

CONTROL PANEL / DISCHARGE CHUTE

SNOW THROWER - MODEL NO. **12527HV** (96193007100), PRODUCT NO. 961 93 00-71

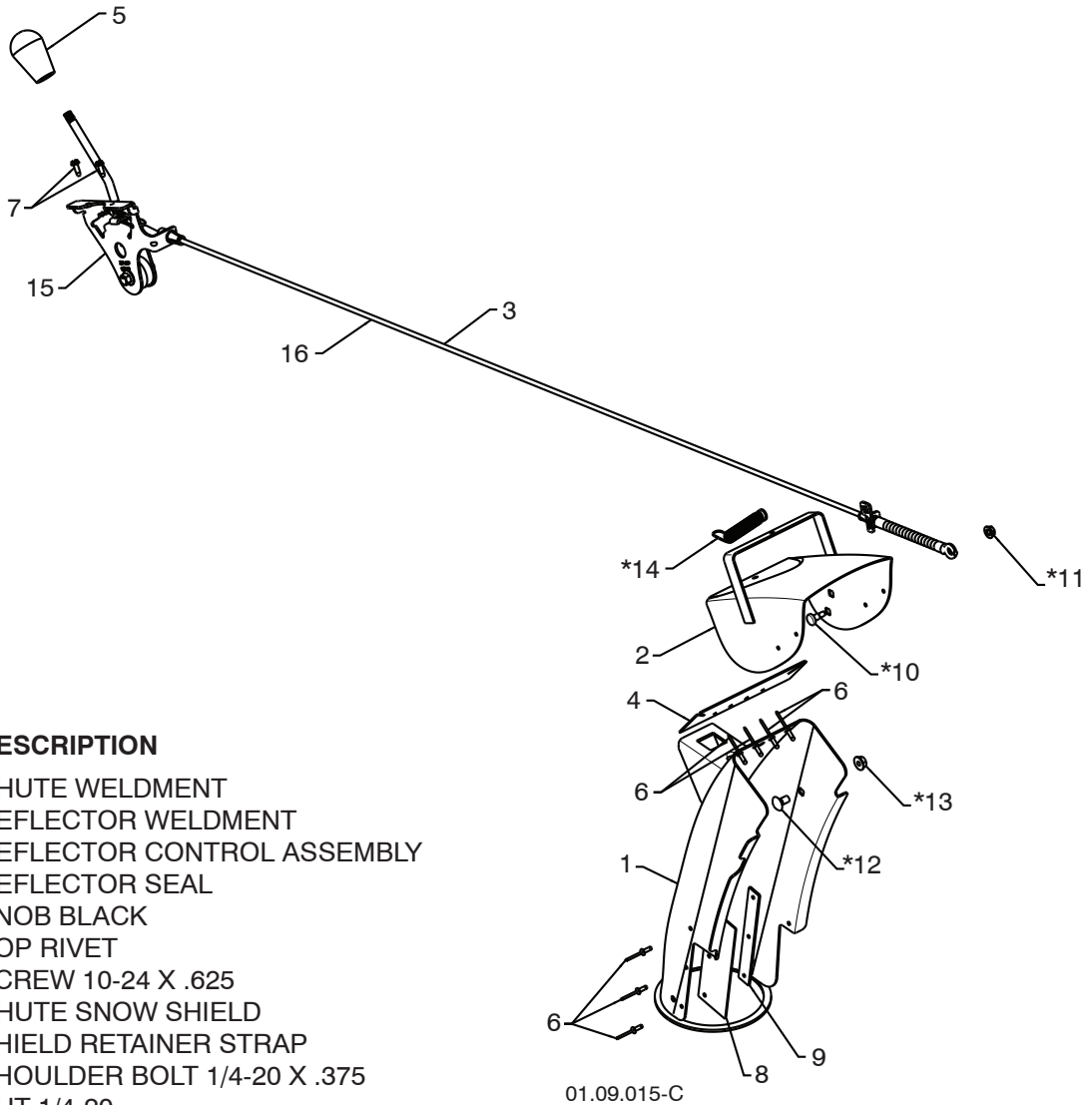

KEY NO.	PART NO.	DESCRIPTION
1	532 44 40-41	CHUTE WELDMENT
2	532 18 41-13	DEFLECTOR WELDMENT
3	532 42 06-73	DEFLECTOR CONTROL ASSEMBLY
4	532 42 03-25	DEFLECTOR SEAL
5	532 41 42-80	KNOB BLACK
6	532 12 84-15	POP RIVET
7	817 50 10-10	SCREW 10-24 X .625
8	532 43 03-24	CHUTE SNOW SHIELD
9	532 42 17-28	SHIELD RETAINER STRAP
*10	532 17 98-29	SHOULDER BOLT 1/4-20 X .375
*11	532 19 17-30	NUT 1/4-20
*12	872 25 05-05	CARRIAGE BOLT 3/8-16 X .625
*13	532 75 11-53	NUT 5/16-18
*14	532 18 45-05	DEFLECTOR SPRING
15	532 42 06-79	(SERVICE PART) DEFLECTOR CONTROL
16	532 42 06-72	(SERVICE PART) DEFLECTOR CABLE BLACK

NOTE:

1. ALL ITEMS INDICATED WITH AN * ARE PROVIDED IN THE BAG OF ITEMS SHIPPED LOOSE WITH PRODUCT.
2. ITEMS 15 AND 16 ARE SERVICE PART NUMBERS TO ALLOW PURCHASE OF INDIVIDUAL ITEMS IF NECESSARY.

NOTE: All component dimensions given in U.S. inches. 1 inch = 25.4 mm
IMPORTANT: Use only Original Equipment Manufacturer (O.E.M.) replacement parts.
 Failure to do so could be hazardous, damage your snow thrower and void your warranty.

REPAIR PARTS

CONTROL PANEL / DISCHARGE CHUTE

SNOW THROWER - MODEL NO. 12527HV (96193007100), PRODUCT NO. 961 93 00-71

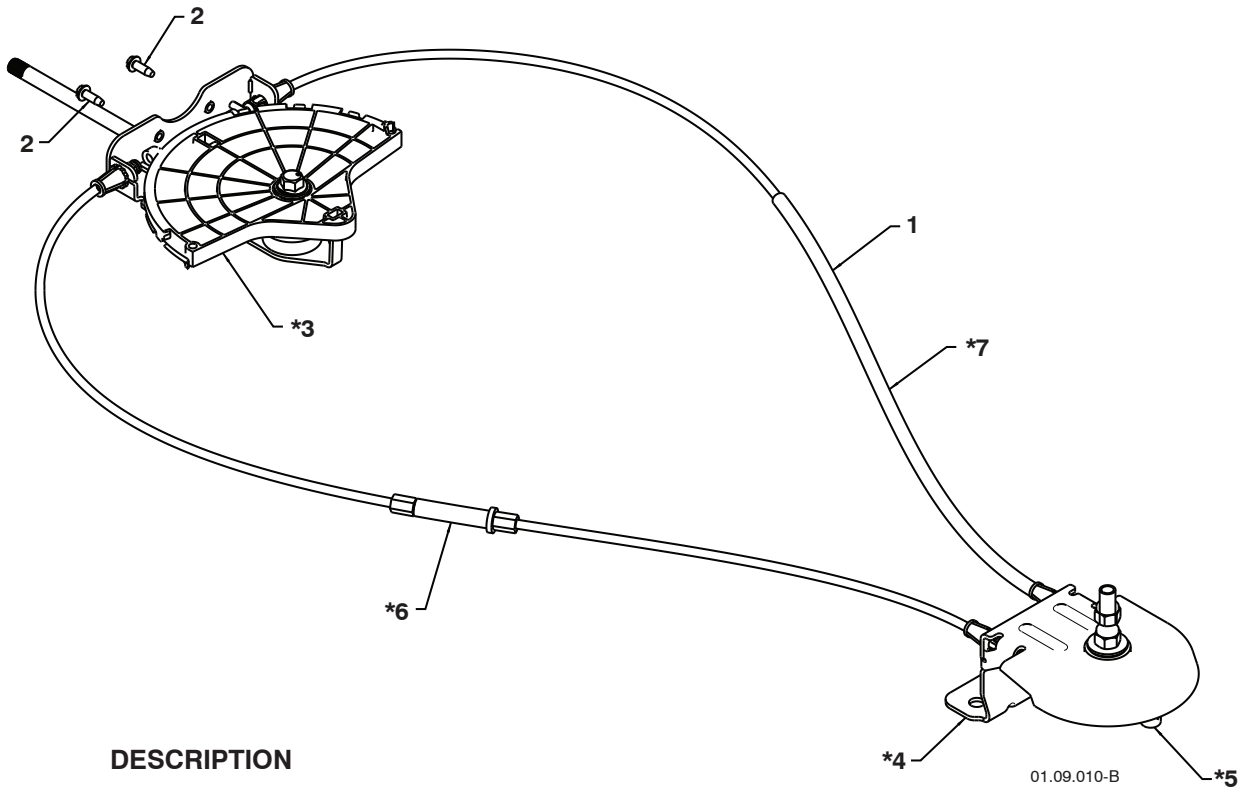

KEY NO.	PART NO.	DESCRIPTION
1	532 42 82-72	LEVER/CABLE ROTATOR ASSEMBLY
2	817 50 10-10	SCREW 10-24 X .625
*3	532 42 06-78	ROTATOR HEAD
*4	532 40 59-32	ROTATOR PIVOT BRACKET
*5	532 42 06-75	PULLEY PIVOT
*6	532 42 82-73	CABLE ASSEMBLY ADJUSTABLE
*7	532 42 83-10	CABLE ASSEMBLY HEAT SHIELD

NOTES:

1. ITEMS INDICATED WITH AN * ARE LISTED AS REFERENCE FOR SERVICE PARTS ONLY.

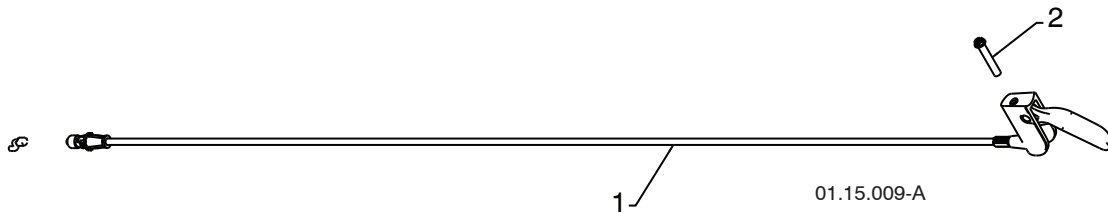

KEY NO.	PART NO.	DESCRIPTION
1	532 42 12-49	STEER CABLE
2	874 04 10-24	SCREW 10-24 X 1.50

NOTE: All component dimensions given in U.S. inches. 1 inch = 25.4 mm
IMPORTANT: Use only Original Equipment Manufacturer (O.E.M.) replacement parts.
 Failure to do so could be hazardous, damage your snow thrower and void your warranty.

REPAIR PARTS

HANDLES

SNOW THROWER - MODEL NO. **12527HV** (96193007100), PRODUCT NO. 961 93 00-71

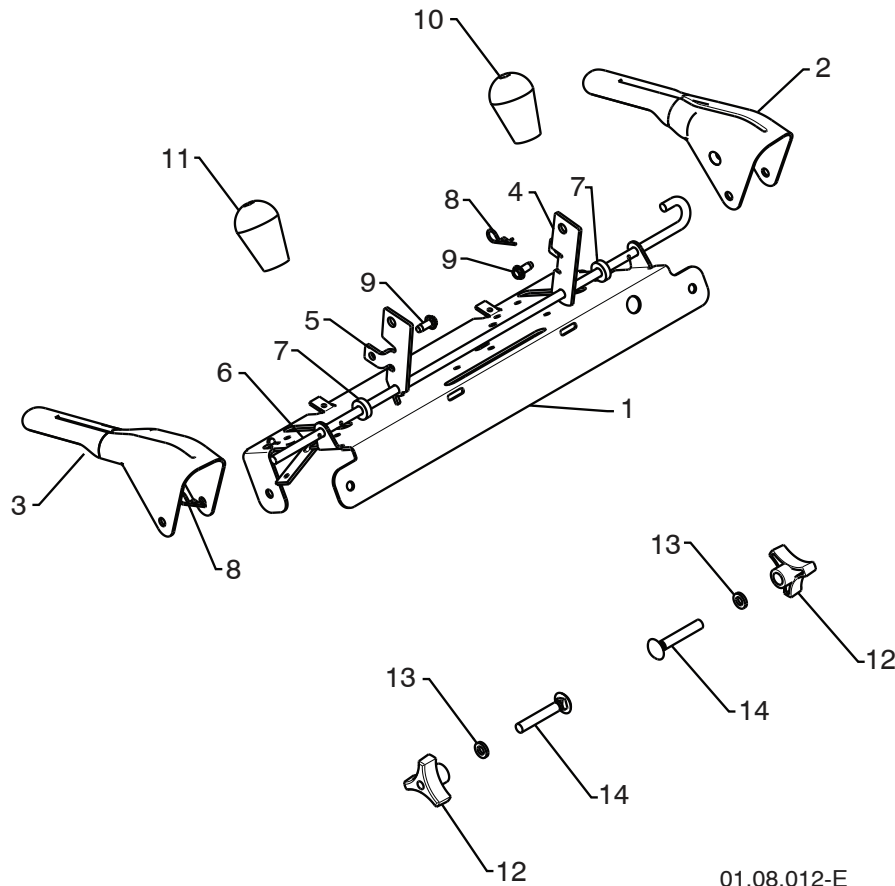

01.08.012-E

KEY NO.	PART NO.	DESCRIPTION
1	532 41 55-39	CONTROL PANEL
2	532 42 91-50	CONTROL LEVER LH
3	532 42 91-51	CONTROL LEVER RH
4	532 41 55-46	TRACTION ROD ARM
5	532 42 90-98	IMPELLER ROD ARM
6	532 41 26-77	INTERLOCK BAIL
7	532 42 16-13	SPACER
8	523 16 96-75	RETAINER
9	817 06 04-10	SCREW 1/4-20 X .62
10	532 41 42-80	KNOB BLACK
11	532 41 42-81	KNOB RED
12	532 17 88-99	HANDLE KNOB
13	819 13 13-16	WASHER 3/8
14	872 12 06-18	CARRIAGE BOLT 3/8-16 X 2.25

NOTE: All component dimensions given in U.S. inches. 1 inch = 25.4 mm
IMPORTANT: Use only Original Equipment Manufacturer (O.E.M.) replacement parts.
Failure to do so could be hazardous, damage your snow thrower and void your warranty.

REPAIR PARTS

HANDLES

SNOW THROWER - MODEL NO. 12527HV (96193007100), PRODUCT NO. 961 93 00-71

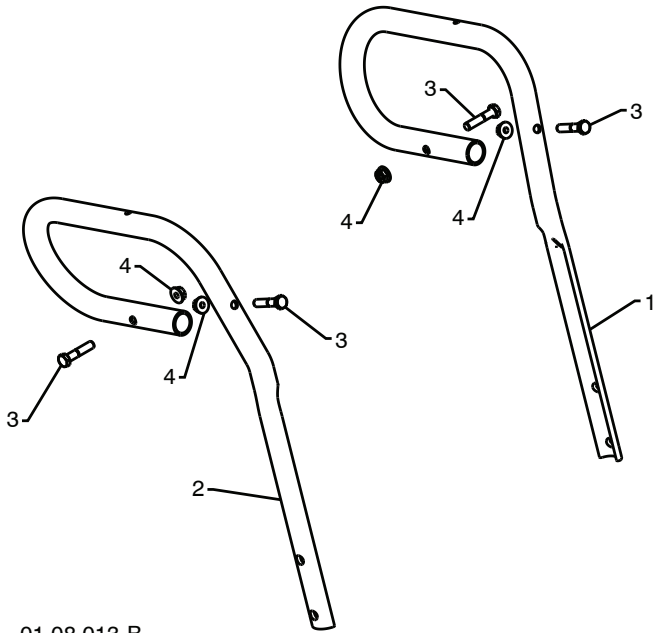

01.08.013-B

KEY NO.	PART NO.	DESCRIPTION
1	532 42 95-88	LOOP HANDLE LH
2	532 42 95-89	LOOP HANDLE RH
3	874 78 05-24	SCREW 5/16-18 X 1.50
4	532 75 11-53	NUT 5/16-18

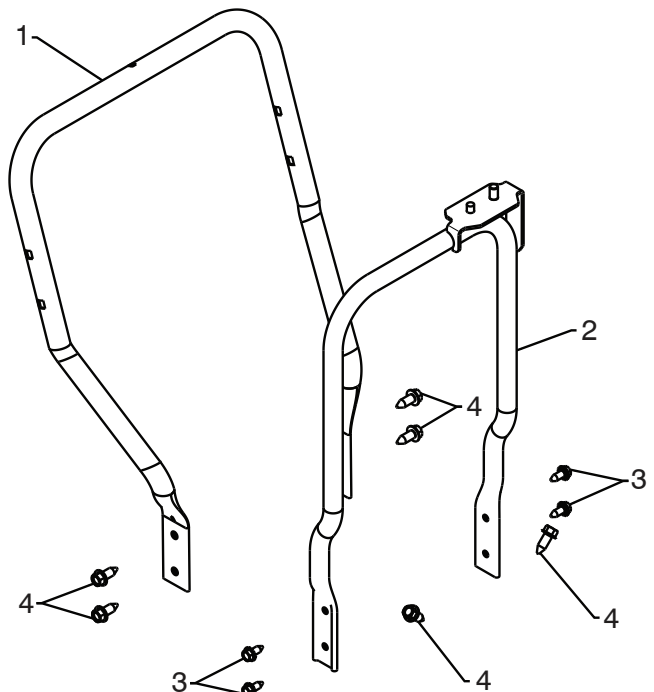

01.05.015-A

KEY NO.	PART NO.	DESCRIPTION
1	532 43 60-43	LOWER HANDLE
2	532 44 36-17	PIVOT SUPPORT
3	817 00 05-10	BOLT 5/16-18
4	817 00 06-16	SCREW 3/8-16 X 1.00

NOTE: All component dimensions given in U.S. inches. 1 inch = 25.4 mm
IMPORTANT: Use only Original Equipment Manufacturer (O.E.M.) replacement parts.
 Failure to do so could be hazardous, damage your snow thrower and void your warranty.

REPAIR PARTS

HANDLES

SNOW THROWER - MODEL NO. **12527HV** (96193007100), PRODUCT NO. 961 93 00-71

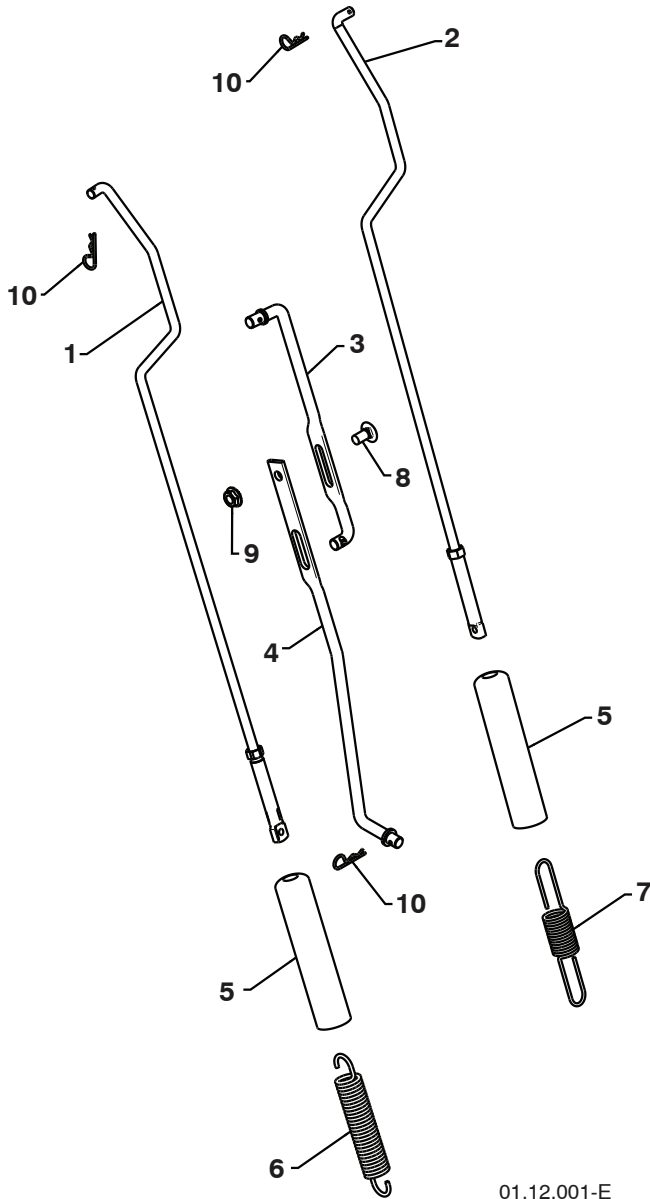

KEY NO.	PART NO.	DESCRIPTION
1	532 18 04-80	IMPELLER ROD ASSEMBLY
2	532 40 57-40	TRACTION ROD ASSEMBLY
3	532 18 04-45	SHIFTER ROD TOP
4	532 18 77-16	SHIFTER ROD BOTTOM
5	532 18 04-47	SPRING SLEEVE
6	532 17 86-69	IMPELLER SPRING
7	532 18 09-26	TRACTION SPRING
8	872 27 05-05	CARRIAGE BOLT 5/16-18 X .625
9	532 15 53-77	NUT 5/16-18
10	532 16 96-75	RETAINER

01.12.001-E

NOTE: All component dimensions given in U.S. inches. 1 inch = 25.4 mm
IMPORTANT: Use only Original Equipment Manufacturer (O.E.M.) replacement parts.
Failure to do so could be hazardous, damage your snow thrower and void your warranty.

REPAIR PARTS

HANDLES

SNOW THROWER - MODEL NO. 12527HV (96193007100), PRODUCT NO. 961 93 00-71

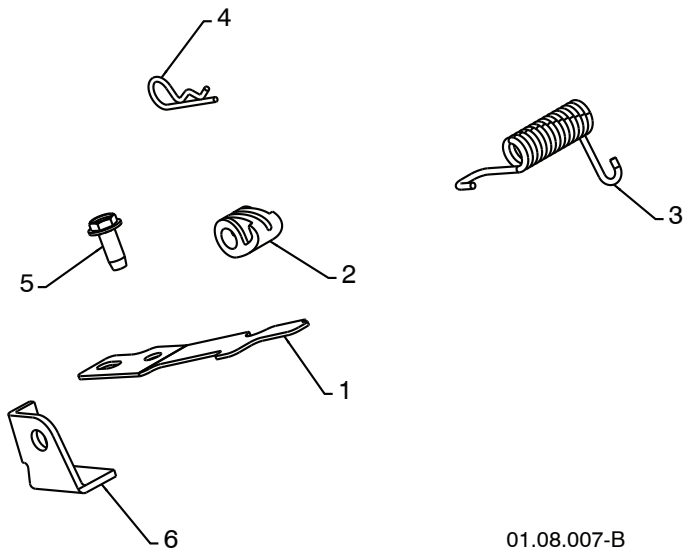

KEY NO.	PART NO.	DESCRIPTION
1	532 41 62-88	INTERLOCK SPRING
2	532 41 45-72	INTERLOCK CAM
3	532 17 88-31	TORSION SPRING
4	532 16 96-75	RETAINER
5	817 06 04-10	SCREW 1/4-20 X .625
6	532 42 18-14	INTERLOCK STOP

01.08.007-B

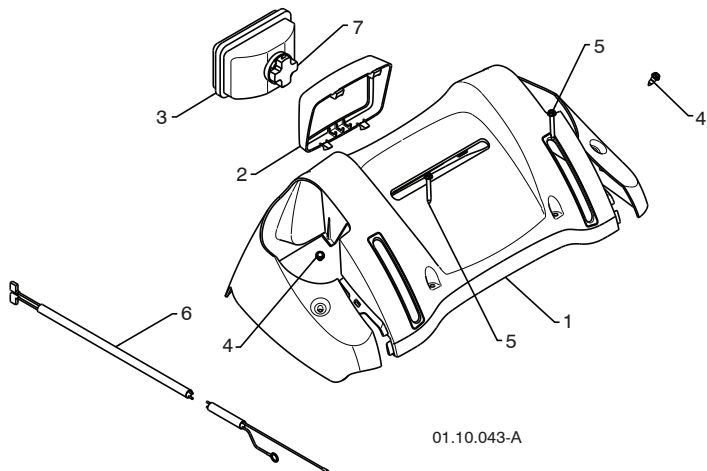

KEY NO.	PART NO.	DESCRIPTION
1	532 42 13-82	CONSOLE PANEL GRAY
2	532 42 14-48	HEADLIGHT BEZEL GRAY
3	532 18 09-27	FLOOD HEADLIGHT
4	532 18 44-71	SHOULDER SCREW 10-24 X .625
5	532 17 52-62	SCREW 10-24 X 1.25
6	532 17 87-70	WIRE HARNESS
7	532 18 37-84	BULB

01.10.043-A

NOTE: All component dimensions given in U.S. inches. 1 inch = 25.4 mm
IMPORTANT: Use only Original Equipment Manufacturer (O.E.M.) replacement parts.
 Failure to do so could be hazardous, damage your snow thrower and void your warranty.

REPAIR PARTS

DRIVE

SNOW THROWER - MODEL NO. 12527HV (96193007100), PRODUCT NO. 961 93 00-71

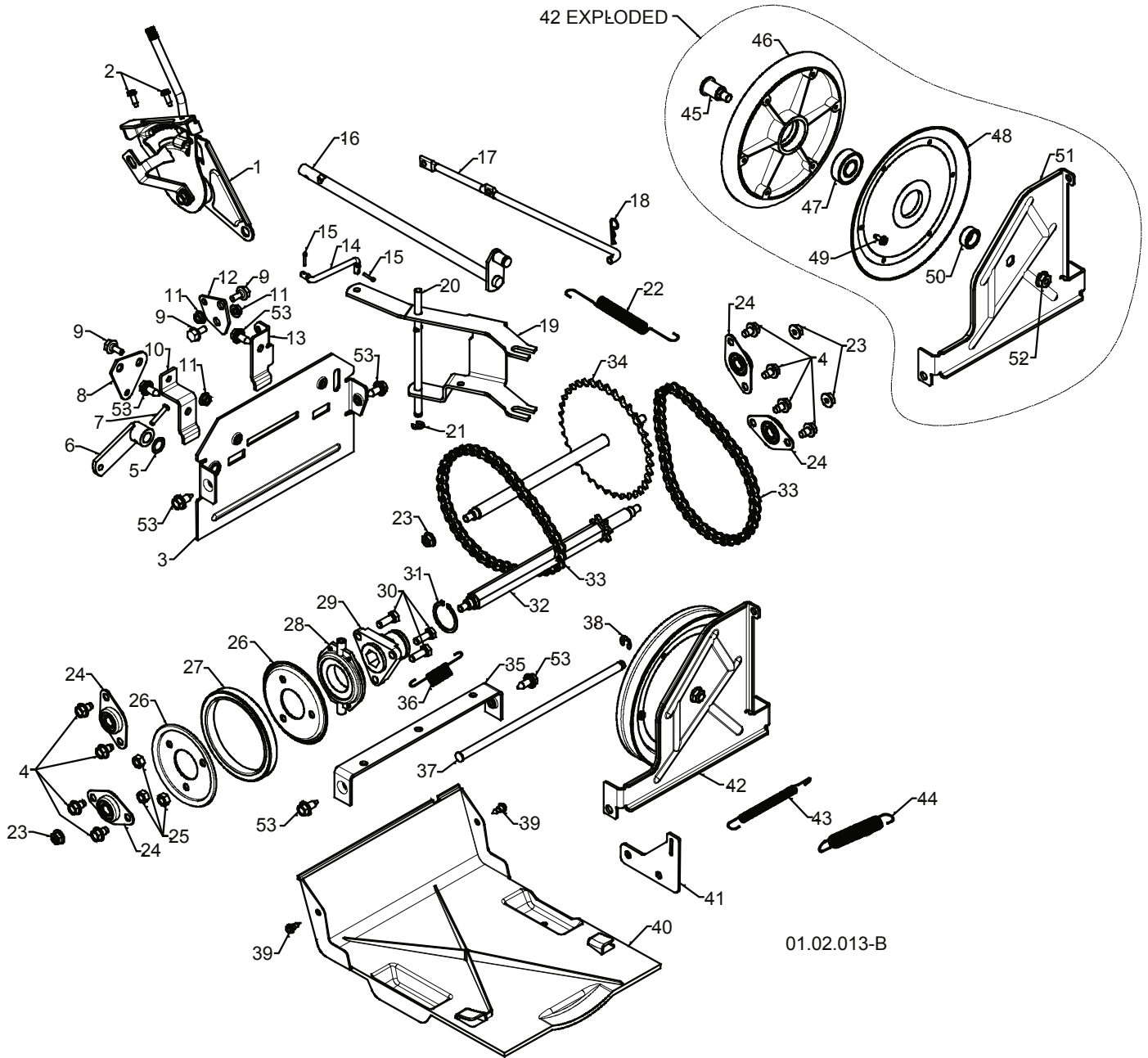

NOTE: All component dimensions given in U.S. inches. 1 inch = 25.4 mm
IMPORTANT: Use only Original Equipment Manufacturer (O.E.M.) replacement parts.
Failure to do so could be hazardous, damage your snow thrower and void your warranty.

REPAIR PARTS**DRIVE****SNOW THROWER - MODEL NO. 12527HV (96193007100), PRODUCT NO. 961 93 00-71**

KEY NO.	PART NO.	DESCRIPTION	KEY NO.	PART NO.	DESCRIPTION
1	532 19 88-75	SPEED SELECTOR ASSEMBLY	28	532 17 53-44	BEARING
2	817 50 10-10	SCREW 10-24 X .625	29	532 17 86-13	WHEEL HUB
3	532 43 60-80	END PLATE	30	874 76 05-14	SCREW 5/16-18-.875
4	817 49 05-08	SCREW 5/16-18 X .50	31	812 00 00-12	RETAINER RING
5	532 05 70-79	WASHER	32	532 40 21-87	SPROCKET SHAFT
6	532 40 54-85	CONTROL ARM	33	532 40 16-19	CHAIN
7	532 19 85-80	CLEVIS PIN	34	532 43 73-03	SPROCKET WELDMENT
8	532 41 54-50	SHIFTER PLATE	35	532 41 54-29	SHIFTER BRACKET
9	532 40 28-81	SHOULDER BOLT	36	532 18 01-35	SPRING
10	532 41 54-33	SHIFTER BRACKET	37	532 40 26-52	PLATE PIVOT ROD
11	532 19 17-30	NUT 1/4-20	38	532 42 82-88	E-RING .375
12	532 41 54-35	CLUTCH PLATE	39	532 18 44-71	SHOULDER SCREW
13	532 41 68-64	CLUTCH BRACKET	40	532 41 08-77	BOTTOM PAN
14	532 18 71-01	SHIFTER LINK	41	532 41 66-82	SPRING BRACKET
15	532 70 02-79	RETAINER	42	532 40 26-89	DRIVE PLATE ASSEMBLY
16	532 42 75-42	CONTROL SHAFT	43	532 41 45-57	IDLER SPRING
17	532 40 25-68	CLUTCH ROD	44	532 17 88-28	IDLER SPRING
18	532 16 96-75	RETAINER	45	532 40 25-04	PULLEY SHAFT
19	532 40 17-32	SHIFTER YOKE	46	532 40 18-20	DRIVE PLATE
20	532 40 23-10	PIVOT ROD	47	532 19 87-91	BEARING
21	812 00 00-36	RETAINER	48	532 40 23-93	PULLEY HALF
22	532 40 28-78	RETURN SPRING	49	817 54 10-08	SCREW 10-24 X .50
23	532 75 11-53	NUT 5/16-18	50	532 40 25-11	SPACER BEARING
24	532 40 89-81	BEARING	51	532 42 29-41	SWING PLATE
25	873 93 05-00	NUT 5/16-18	52	532 13 20-10	NUT 3/8-16
26	532 19 95-09	RUBBER WHEEL PLATE	53	817 00 05-10	SCREW 5/16-18
27	532 44 06-20	RUBBER RING			

NOTE: All component dimensions given in U.S. inches. 1 inch = 25.4 mm**IMPORTANT:** Use only Original Equipment Manufacturer (O.E.M.) replacement parts. Failure to do so could be hazardous, damage your snow thrower and void your warranty.

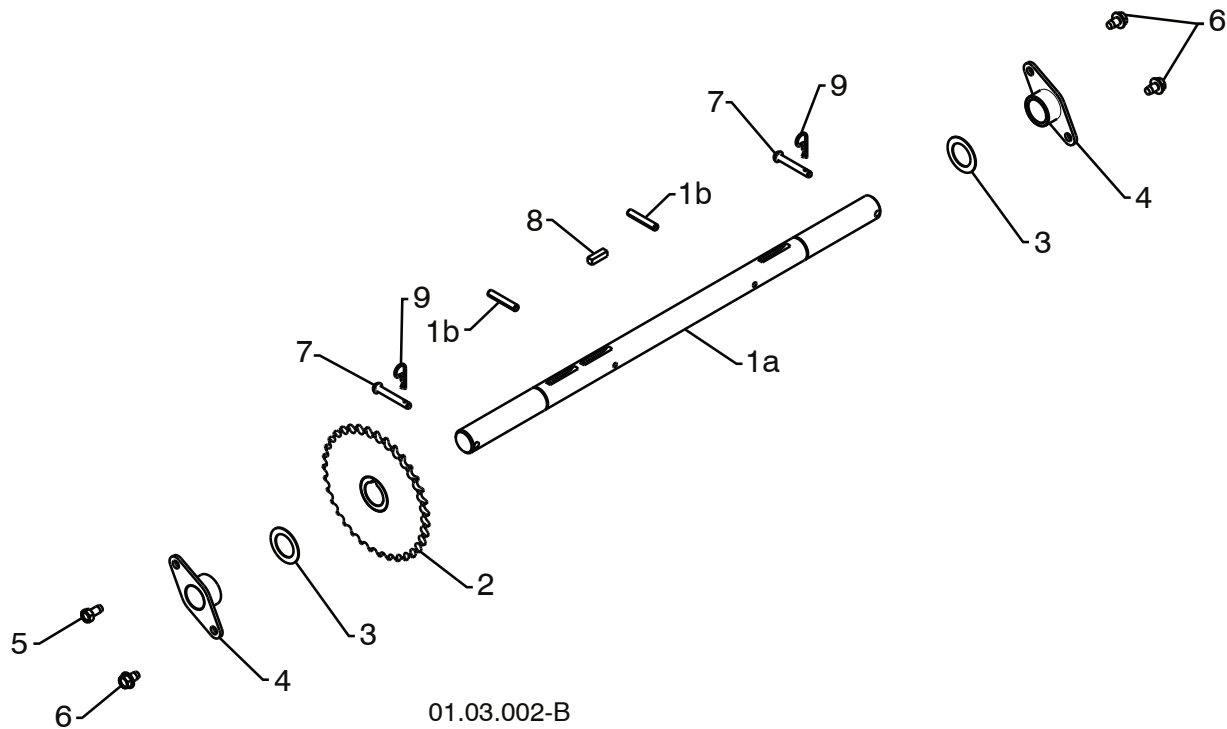

KEY NO.	PART NO.	DESCRIPTION
1	532 40 49-23	AXLE ASSEMBLY (assy of 1a,1b)
1a	532 40 43-07	AXLE SHAFT
1b	532 18 42-06	ROLL PIN 3/16 X 1.50
2	532 40 26-91	SPROCKET
3	532 17 46-97	THRUST WASHER
4	532 17 98-30	BEARING
5	532 14 63-15	SCREW 5/16-18 X .625
6	817 49 05-08	SCREW 5/16-18 X .500
7	532 17 12-71	CLEVIS PIN 1/4 X 1-3/4
8	532 18 92-82	SQUARE KEY
9	532 12 47-88	RETAINER

NOTE: All component dimensions given in U.S. inches. 1 inch = 25.4 mm
IMPORTANT: Use only Original Equipment Manufacturer (O.E.M.) replacement parts.
 Failure to do so could be hazardous, damage your snow thrower and void your warranty.

REPAIR PARTS

CHASSIS / ENGINE / PULLEYS

SNOW THROWER - MODEL NO. 12527HV (96193007100), PRODUCT NO. 961 93 00-71

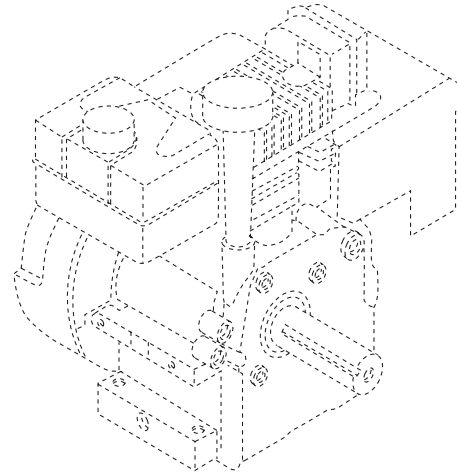
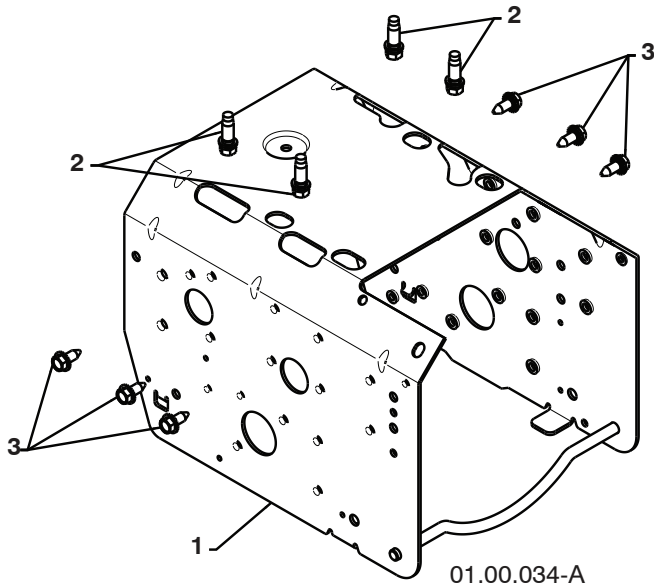

KEY NO.	PART NO.	DESCRIPTION
--	532 44 33-25	COMPLETE LCT ENGINE PW4HK18850781E
1	532 43 59-52	FRAME
2	532 15 04-06	BOLT 3/8-16
3	532 42 88-67	SCREW 5/16-18 X .750

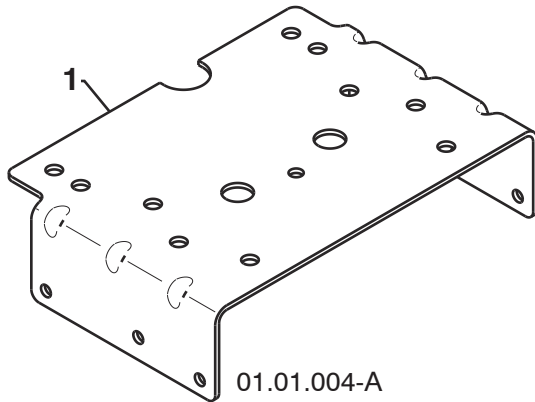

KEY NO.	PART NO.	DESCRIPTION
1	532 42 92-69	ENGINE MOUNTING PLATE

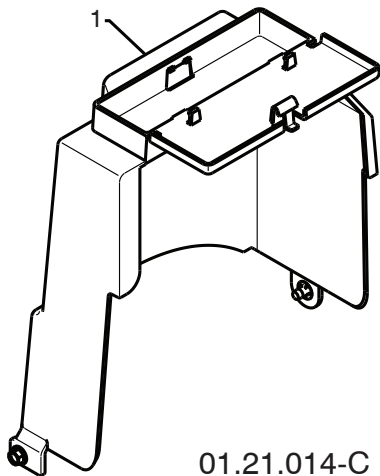

KEY NO.	PART NO.	DESCRIPTION
1	532 42 86-85	COVER ASSEMBLY

NOTE: All component dimensions given in U.S. inches. 1 inch = 25.4 mm
IMPORTANT: Use only Original Equipment Manufacturer (O.E.M.) replacement parts. Failure to do so could be hazardous, damage your snow thrower and void your warranty.

REPAIR PARTS

CHASSIS / ENGINE / PULLEYS

SNOW THROWER - MODEL NO. **12527HV** (96193007100), PRODUCT NO. 961 93 00-71

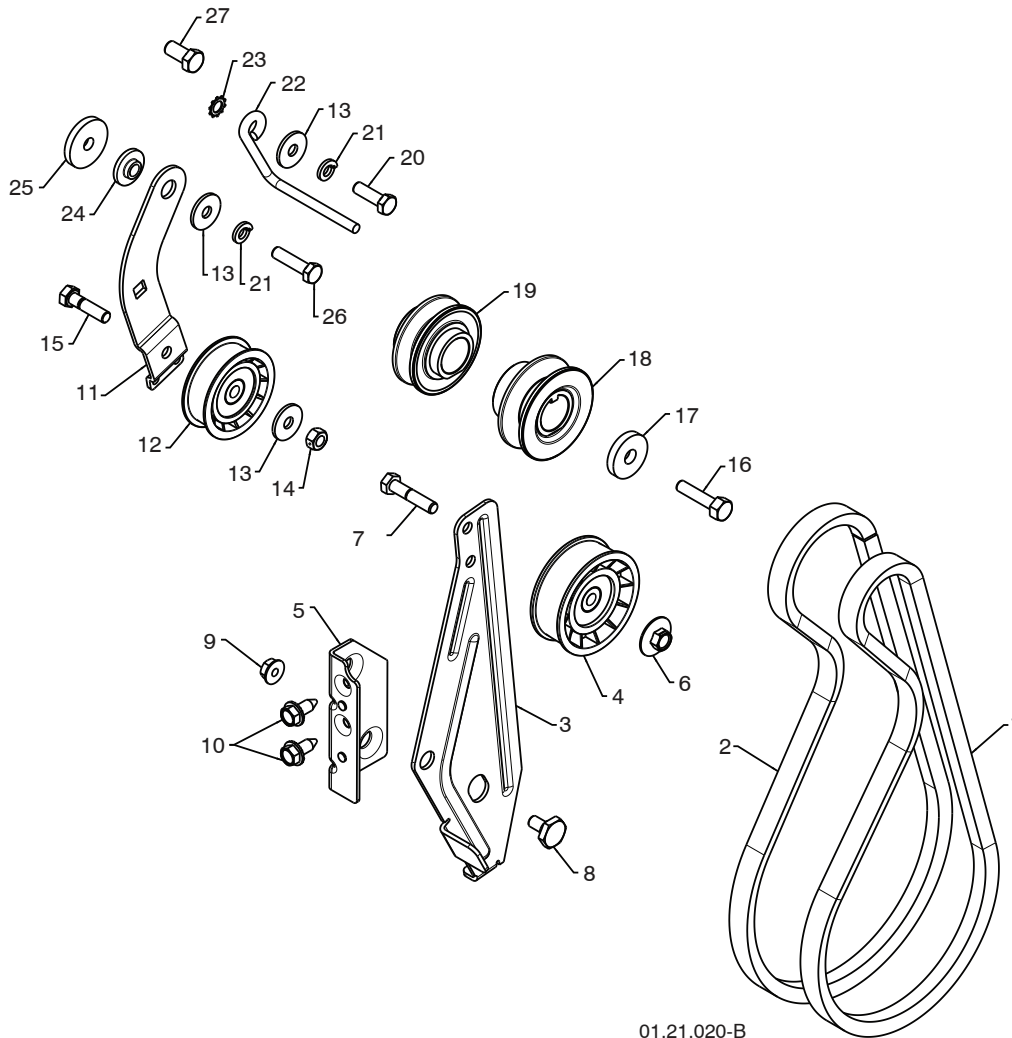

01.21.020-B

KEY NO.	PART NO.	DESCRIPTION	KEY NO.	PART NO.	DESCRIPTION
1	532 41 98-88	IMPELLER BELT	15	874 78 05-20	SCREW 5/16-18 X 1.25
2	532 42 73-04	TRACTION BELT	16	532 85 10-84	SCREW 3/8-24 X 1 .375
3	532 42 92-71	IDLER ARM BRACKET	17	819 13 20-05	WASHER
4	532 18 05-23	IDLER PULLEY	18	532 42 59-34	PULLEY ENG IMPELLER
5	532 42 92-70	IDLER BRACKET	19	532 42 59-33	PULLEY ENG TRACTION
6	532 42 65-89	NUT 5/16-18	20	874 61 05-16	SCREW 5/16-24 X 1.00
7	874 78 05-24	SCREW 5/16-18 X 1.50	21	810 04 05-00	LOCKWASHER 5/16
8	532 42 42-97	SHOULDER BOLT 5/16-18 X .50	22	532 15 54-52	BELT GUIDE
9	532 75 11-53	NUT 5/16-18 LOCK	23	811 05 05-00	LOCKWASHER 5/16
10	817 00 05-10	SCREW 5/16-18	24	532 17 53-31	IDLER BUSHING
11	532 42 75-76	TRACTION IDLER BRACKET	25	819 11 22-06	WASHER
12	532 18 05-22	TRACTION PULLEY	26	874 61 05-20	SCREW 5/16-24 X 1.25
13	532 05 92-89	WASHER	27	974 76 06-08	SCREW 3/8-16 X .750
14	873 80 05-00	NUT 5/16-18			

NOTE: All component dimensions given in U.S. inches. 1 inch = 25.4 mm
IMPORTANT: Use only Original Equipment Manufacturer (O.E.M.) replacement parts.
 Failure to do so could be hazardous, damage your snow thrower and void your warranty.

REPAIR PARTS

WHEELS

SNOW THROWER - MODEL NO. 12527HV (96193007100), PRODUCT NO. 961 93 00-71

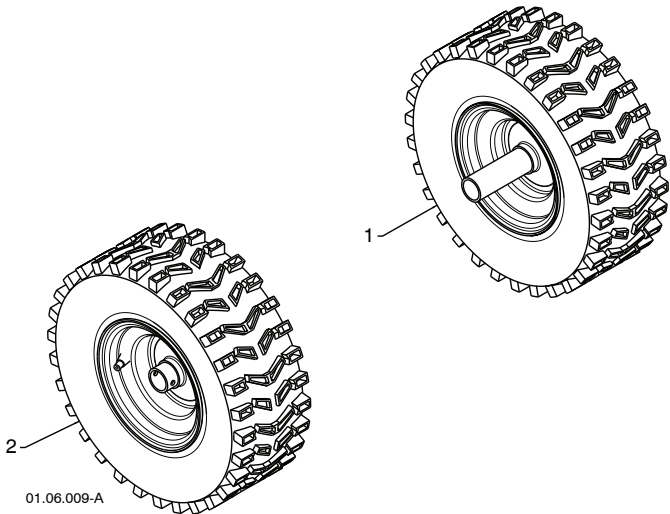

KEY NO.	PART NO.	DESCRIPTION
1	532 43 62-53	WHEEL 16 X 4.80 X LH
2	532 43 62-54	WHEEL 16 X 4.80 X RH

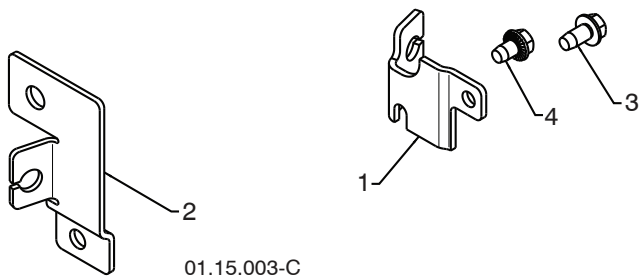

KEY NO.	PART NO.	DESCRIPTION
1	532 41 02-93	CABLE BRACKET LH
2	532 41 02-94	CABLE BRACKET RH
3	817 49 04-08	SCREW 1/4-20 X .500
4	817 60 04-06	SCREW 1/4-20 X .375

NOTE: All component dimensions given in U.S. inches. 1 inch = 25.4 mm
IMPORTANT: Use only Original Equipment Manufacturer (O.E.M.) replacement parts.
Failure to do so could be hazardous, damage your snow thrower and void your warranty.

REPAIR PARTS

WHEELS

SNOW THROWER - MODEL NO. **12527HV** (96193007100), PRODUCT NO. 961 93 00-71

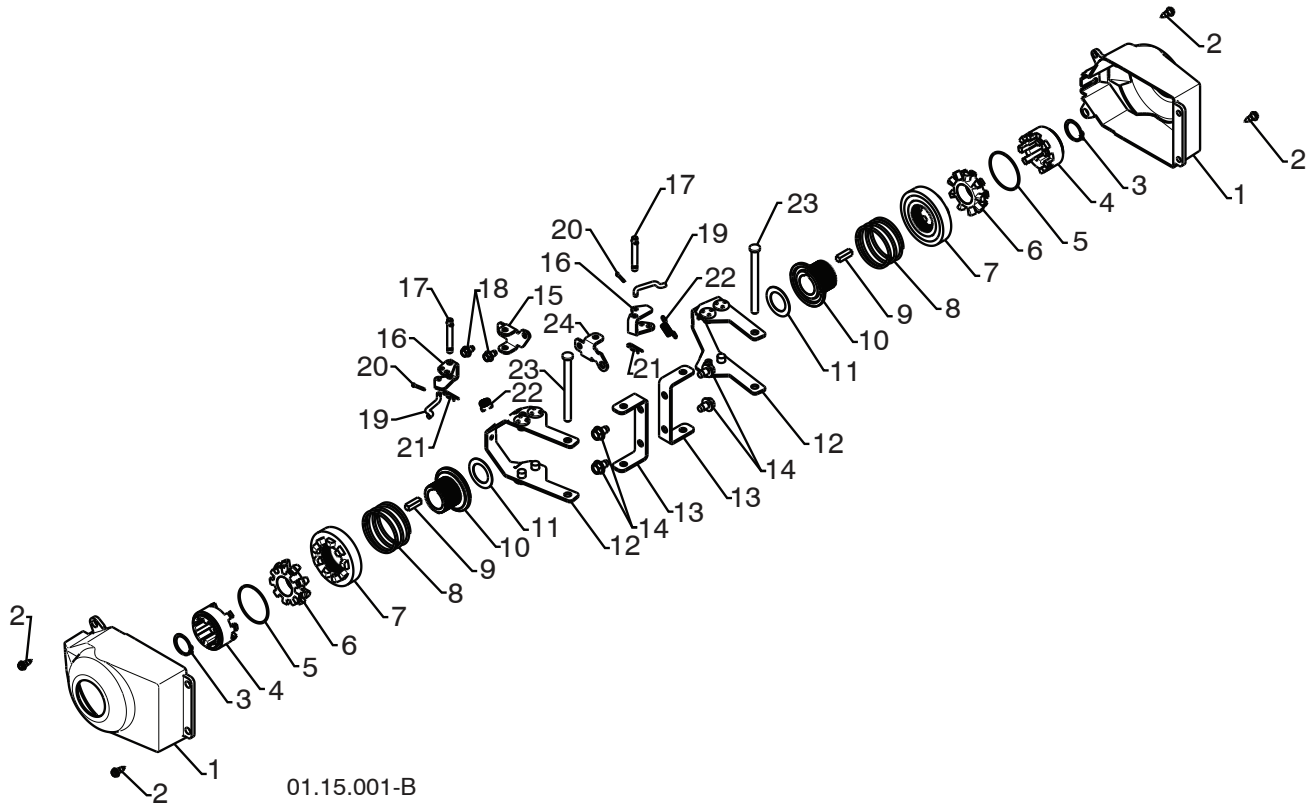

KEY NO.	PART NO.	DESCRIPTION
1	532 40 51-61	COVER
2	532 18 44-71	SHOULDER SCREW
3	812 00 00-45	RETAINER RING
4	532 19 21-26	WHEEL DRIVER
5	532 18 24-66	RETAINER RING
6	532 18 76-22	WHEEL LOBE
7	532 19 49-41	CLUTCH SLIDE
8	532 17 91-39	SPRING
9	532 18 92-82	SQUARE KEY
10	532 19 49-40	AXLE LOBE
11	532 17 46-97	THRUST WASHER
12	532 19 95-19	STEERING YOKE
13	532 18 41-97	STEERING BRACKET
14	817 49 05-08	SCREW 5/16-18 X .50
15	532 19 95-11	PIVOT BRACKET
16	532 19 95-18	BELLCRANK
17	532 18 18-47	BELLCRANK PIN
18	817 60 04-06	SCREW 1/4-20 X .375
19	532 40 50-77	STEERING LINK
20	532 70 02-79	RETAINER
21	532 08 51-79	RETAINER
22	532 19 38-85	SPRING
23	532 18 20-15	LEVER PIN
24	532 19 95-12	PIVOT BRACKET

NOTE: All component dimensions given in U.S. inches. 1 inch = 25.4 mm
IMPORTANT: Use only Original Equipment Manufacturer (O.E.M.) replacement parts.
 Failure to do so could be hazardous, damage your snow thrower and void your warranty.

REPAIR PARTS

BAG OF PARTS

SNOW THROWER - MODEL NO. 12527HV (96193007100), PRODUCT NO. 961 93 00-71

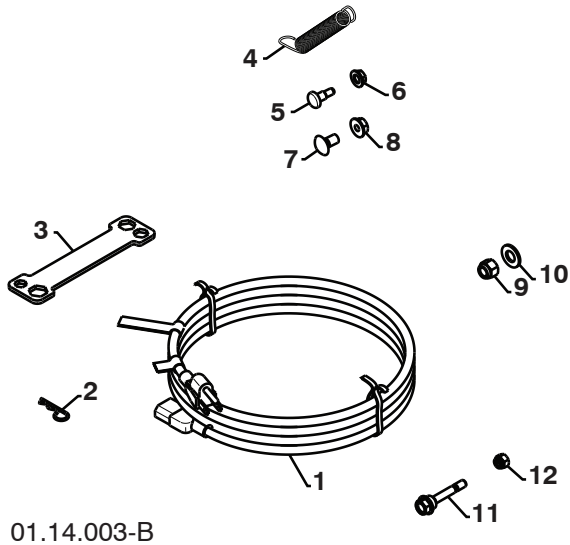

01.14.003-B

KEY NO.	PART NO.	DESCRIPTION
1	532 19 85-63	POWER CORD
2	532 16 96-75	RETAINER PIN
3	532 42 91-12	WRENCH
4	532 18 45-05	REMOTE SPRING
5	532 17 98-29	SHOULDER BOLT 1/4-20
6	532 19 17-30	LOCKNUT 1/4-20
7	872 25 05-05	CARRIAGE BOLT 5/16-18 X 5/8
8	532 75 11-53	LOCKNUT 5/16-18
9	873 80 06-00	LOCKNUT 3/8-16
10	819 13 13-16	WASHER 3/8
11	532 19 20-90	SHEAR BOLT 1/4-20 X 1-13/16
12	873 80 04-00	LOCKNUT 1/4-20

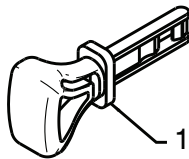

01.14.009-B

KEY NO.	PART NO.	DESCRIPTION
1	532 44 30-59	SAFETY IGNITION KEY KIT

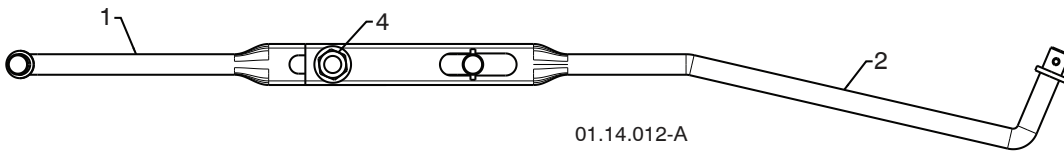
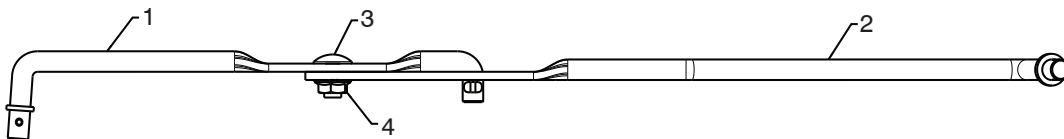

01.14.012-A

KEY NO.	PART NO.	DESCRIPTION
1	532 18 04-45	SHIFTER ROD TOP
2	532 18 77-16	SHIFTER ROD BOTTOM
3	872 27 05-05	CARRIAGE BOLT 5/16-18 X .75
4	532 15 53-77	NUT 5/16-18

NOTE: All component dimensions given in U.S. inches. 1 inch = 25.4 mm
IMPORTANT: Use only Original Equipment Manufacturer (O.E.M.) replacement parts.
 Failure to do so could be hazardous, damage your snow thrower and void your warranty.

REPAIR PARTS

DECALS

SNOW THROWER - MODEL NO. **12527HV** (96193007100), PRODUCT NO. 961 93 00-71

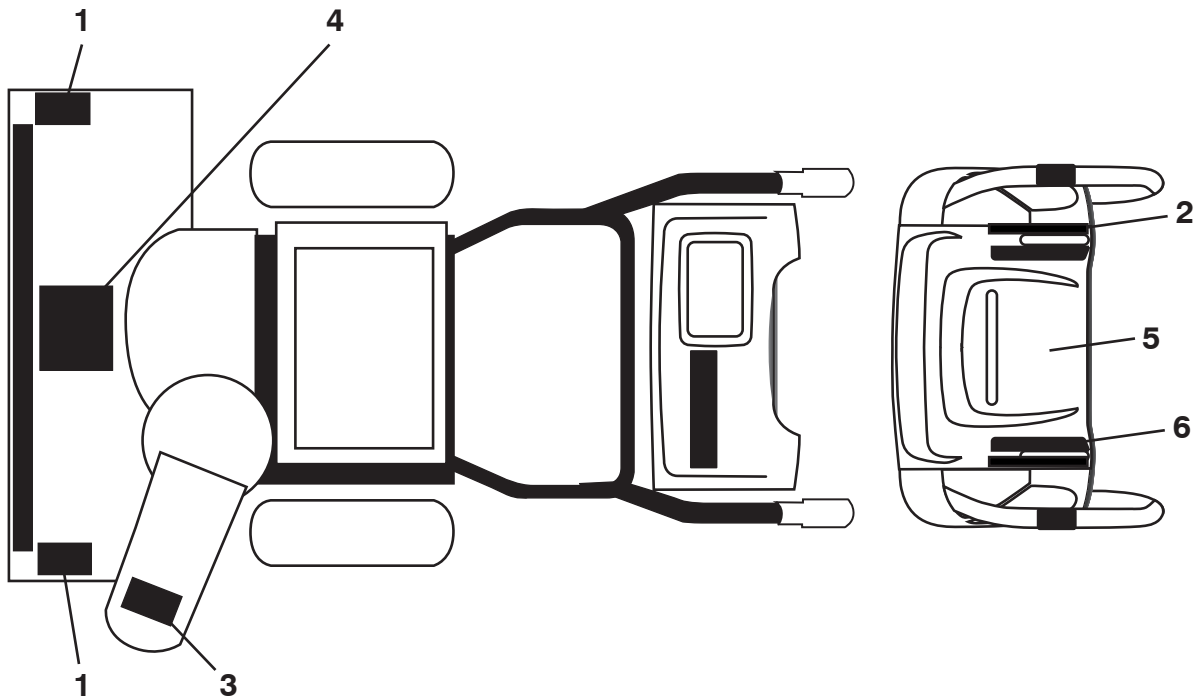

KEY NO.	PART NO.	DESCRIPTION
1	532 18 10-37	DECAL, DANGER
2	532 42 95-71	DECAL
3	532 18 10-35	DECAL, DANGER, DEFLECTOR
4	532 18 10-42	DECAL, DANGER
5	532 42 95-73	DECAL
6	532 42 95-69	DECAL
--	532 44 34-44	OPERATOR'S MANUAL, ENGLISH
--	532 44 34-45	OPERATOR'S MANUAL, FRENCH

NOTE: All component dimensions given in U.S. inches. 1 inch = 25.4 mm
IMPORTANT: Use only Original Equipment Manufacturer (O.E.M.) replacement parts.
Failure to do so could be hazardous, damage your snow thrower and void your warranty.

