



# GTH26V52LS

---

## ILLUSTRATED PARTS LIST

Gasoline containing up to 10% ethanol (E10) is acceptable for use in this machine.  
The use of any gasoline exceeding 10% ethanol (E10) will void the product warranty.

# TRACTOR - MODEL NO. GTH26V52LS (96043011802), PRODUCT NO. 960 43 01-18 SCHEMATIC

SCH12

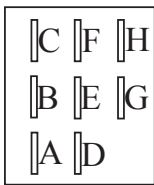
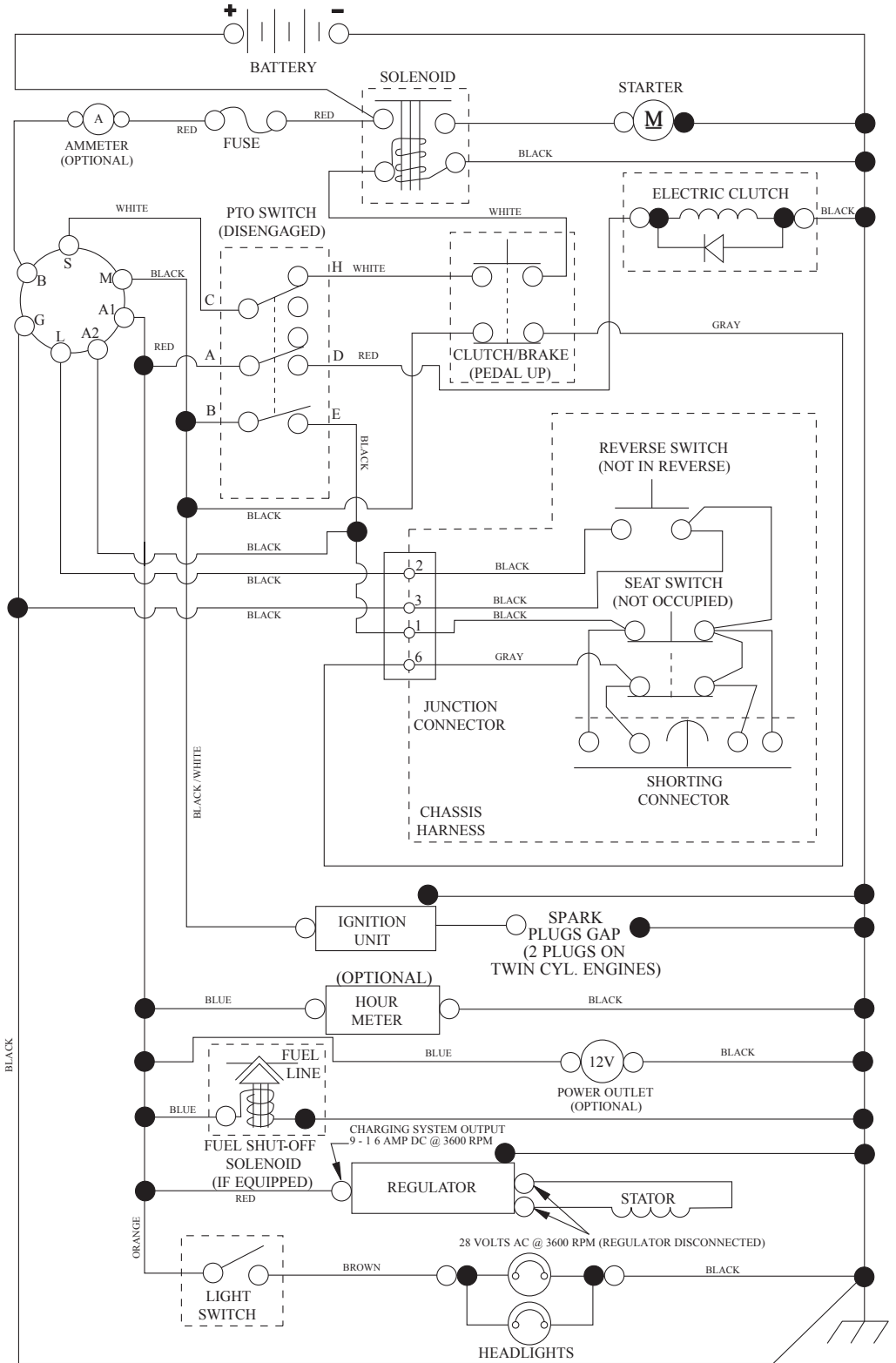

PTO SWITCH  
(MATING SIDE)

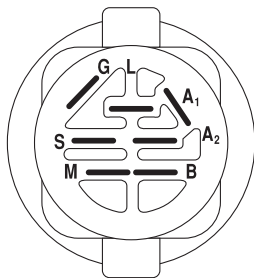

IGNITION SWITCH

POSITION	CIRCUIT	"MAKE"
OFF	M+G+A1	
RUN/OVERRIDE	B+A1	
RUN	B+A1	L+A2
START	B + S + A1	

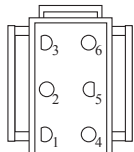

CHASSIS HARNESS  
CONNECTOR  
(MATING SIDE)

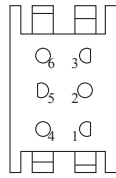

DASH HARNESS  
CONNECTOR

WIRING INSULATED CLIPS  
NOTE: IF WIRING INSULATED  
CLIPS WERE REMOVED FOR  
SERVICING OF UNIT, THEY  
SHOULD BE RE-INSTALLED TO  
PROPERLY SECURE YOUR  
WIRING.

●  
NON-REMOVABLE  
CONNECTIONS

○  
REMOVABLE  
CONNECTIONS

**TRACTOR - MODEL NO. GTH26V52LS (96043011802), PRODUCT NO. 960 43 01-18  
ELECTRICAL**

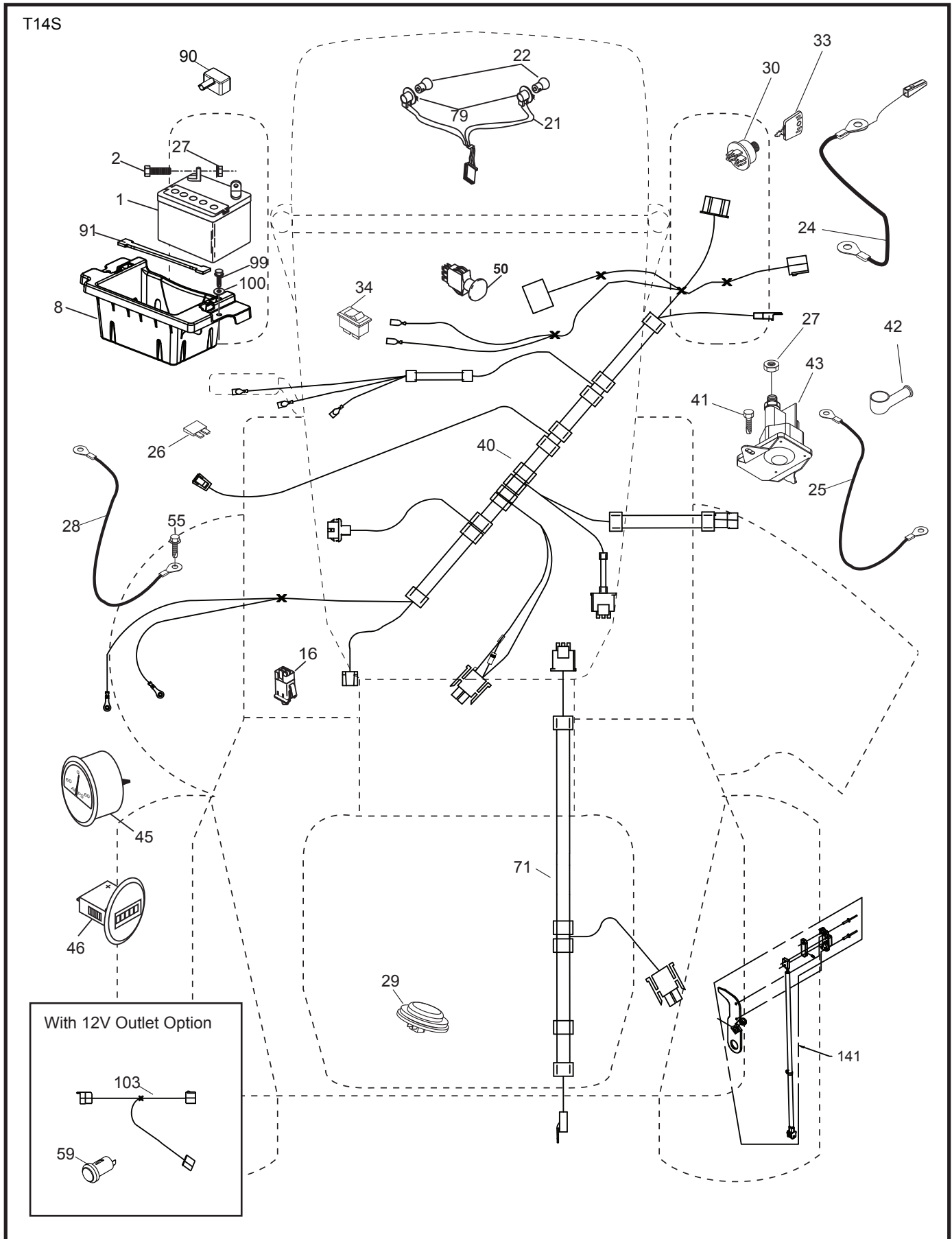

**TRACTOR - MODEL NO. GTH26V52LS (96043011802), PRODUCT NO. 960 43 01-18  
ELECTRICAL**

<b>KEY NO.</b>	<b>PART NO.</b>	<b>DESCRIPTION</b>
1	532 16 34-65	Battery
2	874 76 04-12	Bolt Hex Hd 1/4-20 unc x 3/4
8	532 18 64-91	Battery Box
16	532 17 61-38	Switch Interlock
21	532 40 02-52	Harness Socket Light
22	532 00 41-52	Bulb, Light #1156
24	532 40 02-53	Cable Battery
25	532 41 28-95	Cable Starter
26	532 17 51-58	Fuse
27	873 51 04-00	Nut Keps Hex 1/4-20 unc
28	532 14 54-91	Cable Ground 21" Blk 6 Ga.
29	532 40 15-45	Switch Seat
30	532 19 33-50	Switch Ign
33	532 41 19-33	Key/Chain
34	532 11 07-12	Switch Light/Reset
40	532 40 21-67	Harness Ign. Dash
41	817 72 04-08	Screw 1/4-20 unc x 1/2
42	532 13 15-63	Cover Terminal Red
43	532 19 25-07	Solenoid
45	532 42 52-70	Ammeter Round
46	532 42 52-71	Gauge Hourmeter
50	532 17 46-51	Switch PTO
55	817 06 05-12	Screw Thdrol 5/16-18 x 3/4
59	532 40 03-03	Outlet 12-Volt
71	532 19 42-76	Harness Ign
79	532 17 52-42	Socket Asm. Bulb Twistlock
90	532 43 53-95	Cover Terminal Battery
91	532 19 02-70	Strap Battery
99	817 67 04-12	Screw Hexwsh Thdrol 1/4-20 x 3/4
100	819 09 14-16	Washer 9/32 x 7/8 x 16 Ga.
103	532 42 17-47	Harness Pigtail 12V Outlet
141	532 42 12-25	Kit G700/G730 ROS

**NOTE:** All component dimensions given in U.S. inches  
1 inch = 25.4 mm

**TRACTOR - MODEL NO. GTH26V52LS (96043011802), PRODUCT NO. 960 43 01-18  
CHASSIS**

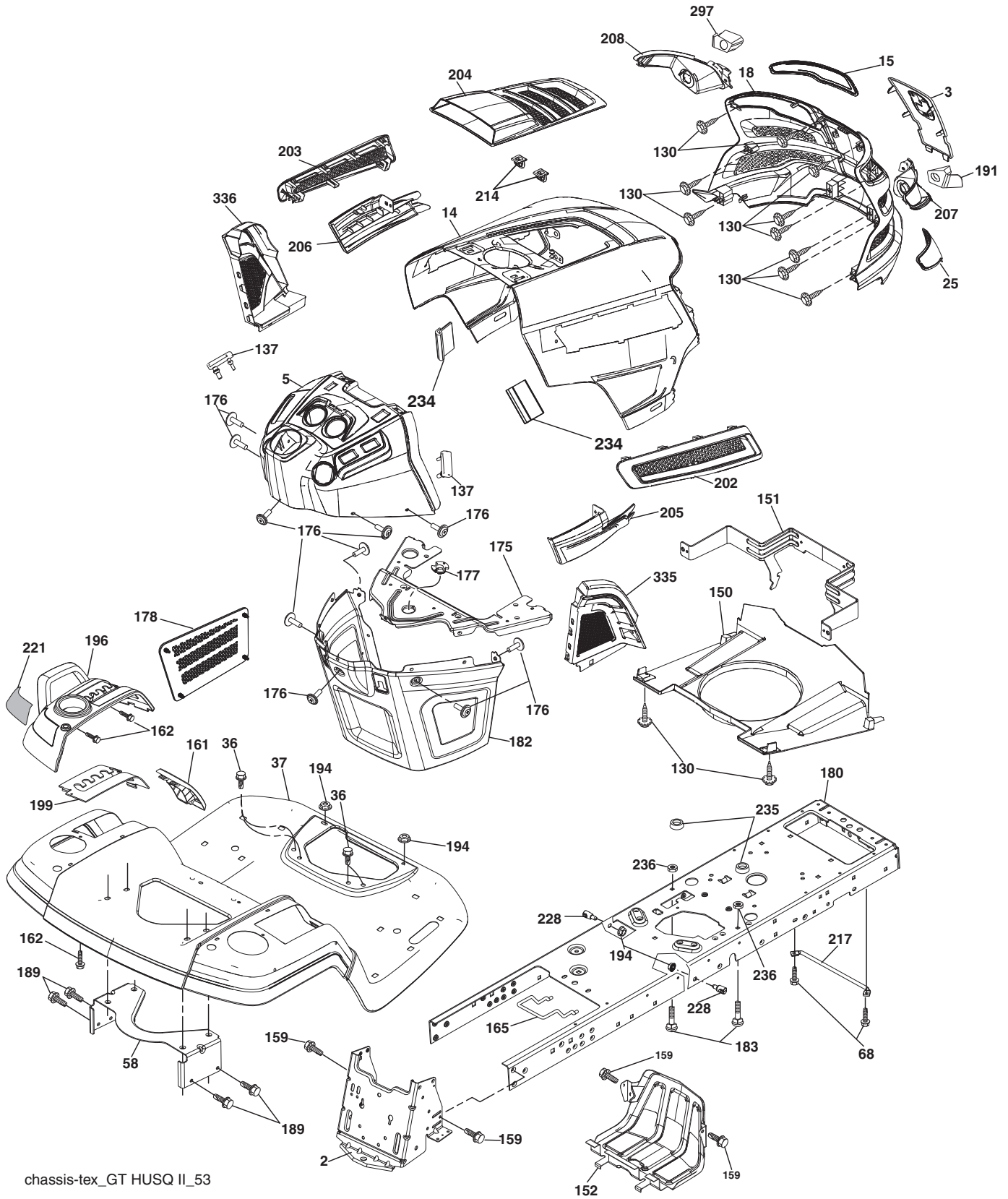

chassis-tex\_GT HUSQ II\_53

**TRACTOR - MODEL NO. GTH26V52LS (96043011802), PRODUCT NO. 960 43 01-18  
CHASSIS**

KEY NO.	PART NO.	DESCRIPTION
2	532 19 42-61	Drawbar
3	532 43 97-52	Logo Husq.
5	532 43 74-70	Dash
14	532 44 11-77	Hood
15	532 43 97-33	Lens LH
18	532 43 77-62	Grille Asm
25	532 44 33-85	Lens RH
36	817 06 05-12	Screw 5/16-18 x 3/4
37	532 44 12-08	Fender
58	532 19 43-14	Bracket Fender
68	817 49 05-08	Screw 5/16-18 x 1/2
130	532 41 63-58	Screw #10 x 0.750 BOS Thread
137	532 40 75-90	Bumper Dash
150	532 43 97-74	Duct Air
151	532 43 66-70	Bracket Pivot Hood
152	532 43 98-70	Shield Browning/Debris
159	817 00 06-12	Screw 3/8-16 x 3/4
161	532 43 99-29	Console Fuel Window
162	532 14 24-32	Screw Hex Wsh Hi-Lo 1/4 x 1/2
165	532 19 43-30	Bracket Support Tank
175	532 19 63-04	Crossmember
176	532 40 07-76	Screw 10-24 x 5/8 Wshd Qdrx
177	532 19 52-27	Bushing Steering
178	532 19 97-82	Cargo Asm. Net
180	532 19 42-60	Chassis
182	532 40 68-59	Dash Lower

KEY NO.	PART NO.	DESCRIPTION
183	874 52 05-20	Bolt 5/16-18 x 1-1/4
189	817 00 05-12	Screw 5/16-18 x 3/4
191	532 43 74-55	Insert Reflective RH
194	873 90 05-00	Nut Lock Hex Flange 5/16-18
196	532 43 96-74	Console Asm. Deck Lift
199	532 19 82-59	Plate Deck Lift
202	532 43 97-28	Vent Side Hood RH
203	532 43 97-27	Vent Side Hood LH
204	532 43 57-14	Vent Asm Hood Top
205	532 43 97-30	Skirt Hood Side RH
206	532 43 97-29	Skirt Hood Side LH
207	532 43 97-34	Bezel RH
208	532 43 97-35	Bezel LH
214	532 19 91-45	Clip Retainer
217	532 40 91-67	Rod Pivot
221	532 19 89-09	Reflector LH
228	532 19 51-61	Stud Fastener
234	532 40 47-42	Bumper Hood
235	532 40 61-29	Spacer Fender
236	873 93 05-00	Nut Center Lock 5/16-18 unc
297	532 43 74-56	Insert Reflective LH
335	532 43 98-47	Cover RH
336	532 43 98-46	Cover LH
--	532 42 49-18	Kit Guard Brush

**NOTE:** All component dimensions given in U.S. inches  
1 inch = 25.4 mm

**TRACTOR - MODEL NO. GTH26V52LS (96043011802), PRODUCT NO. 960 43 01-18  
DRIVE**

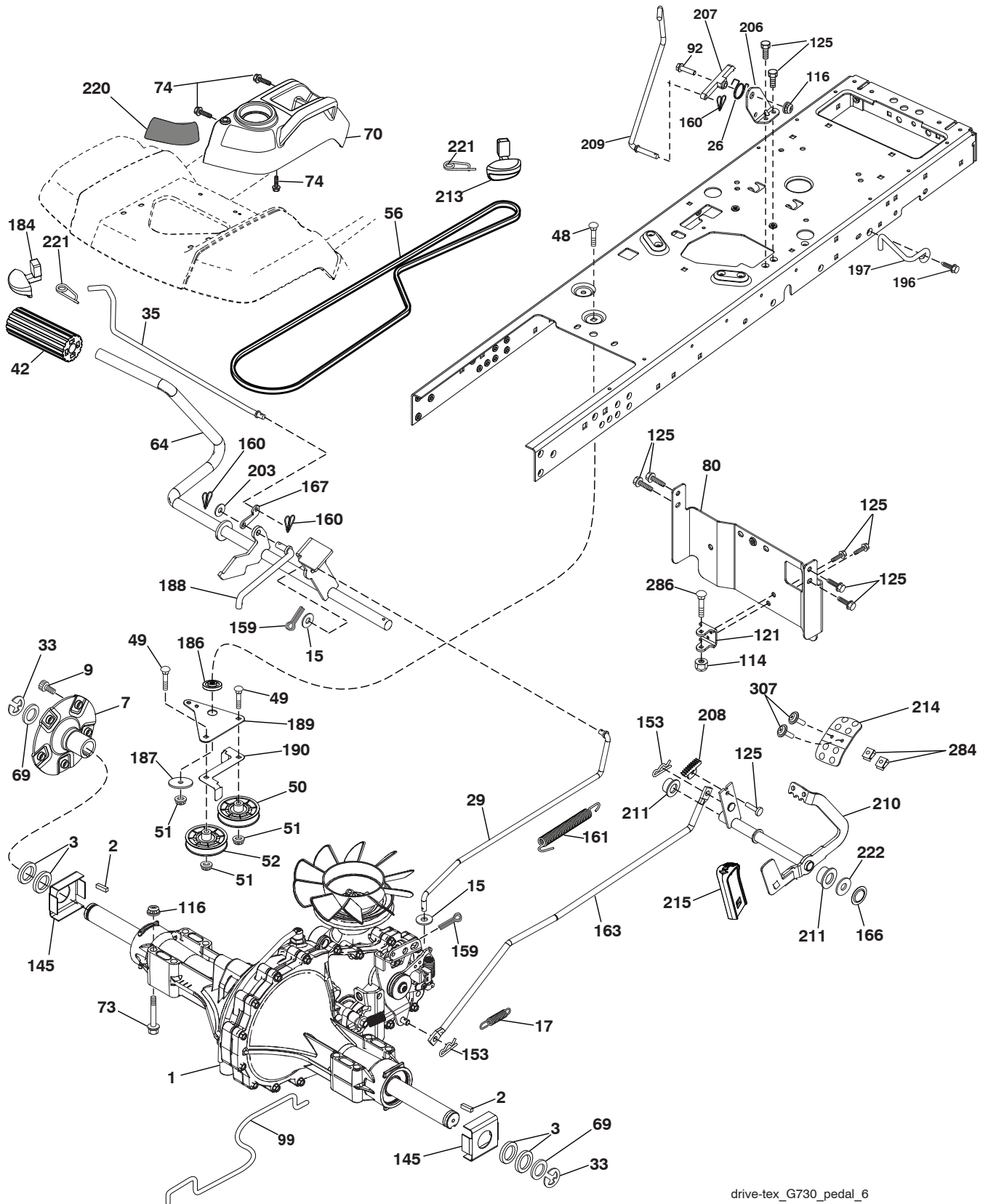

drive-tex\_G730\_pedal\_6



**TRACTOR - MODEL NO. GTH26V52LS (96043011802), PRODUCT NO. 960 43 01-18  
DRIVE**

KEY NO.	PART NO.	DESCRIPTION	KEY NO.	PART NO.	DESCRIPTION
1	---	Transaxle, Hydro G7-BCBB-1XDC-1FCA (420331)(Order parts from transaxle manufacturer)	153	532 12 47-88	Retainer Spring
2	532 00 70-70	Key 1/4 x 2.5	159	876 02 04-12	Pin Cotter 1/8 x 3/4
3	532 00 75-63	Washer Thrust Axle Hardened	160	532 16 94-84	Retainer Clip
7	532 19 98-37	Hub Asm. Wheel	161	532 10 57-09	Spring, Return, Clutch
9	532 14 00-80	Bolt Hub Wheel	163	532 41 81-85	Rod Pedal Control
15	819 13 13-16	Washer 13/32 x 13/16 x 16 Ga.	166	532 42 91-64	Nut Push .625
17	532 19 72-96	Spring, Brake	167	532 40 52-57	Latch Brake Parking
26	532 19 96-79	Spring Return Cruise	184	532 44 14-55	Handle Parking Brake
29	532 41 81-86	Rod, Brake	186	532 19 43-21	Spacer Retainer
33	812 00 00-53	Ring E	187	819 13 32-10	Washer
35	532 43 54-86	Rod, Brake, Park	188	532 19 43-23	Link Clutch Ground Drive
42	532 12 48-72	Cover, Foot Pedal	189	532 40 75-04	Bellcrank Ground Drive
48	872 11 06-12	Bolt Carr Sh 3/8-16 x 1-1/2 Gr.5	190	532 40 75-05	Keeper Bellcrank Ground Drive
49	872 11 06-14	Bolt	196	817 00 06-16	Screw 3/8-16 x 1
50	532 19 43-27	Pulley Idler Flat	197	532 19 97-69	Bracket Clutch Anti-Rotation
51	873 90 06-00	Lock Nut 3/8-16	203	819 11 11-16	Washer 11/32 x 11/16 x 16 Ga.
52	532 19 43-26	Idler V-Groove 910" Offset	206	532 19 78-67	Bracket Mount Latch Cruise
56	532 42 08-07	V-Belt, Drive	207	532 19 78-68	Latch Control Cruise
64	532 19 78-65	Shaft Asm. Pedal Brake Control	208	532 19 78-69	Gear Sector Control Cruise
69	532 12 38-00	Washer 1-1/32 x 1-5/8 x 16 Ga.	209	532 19 95-92	Rod Control Cruise
70	532 43 96-61	Console Asm	210	532 19 78-60	Rocker Asm. Pedal Control
73	874 49 05-48	Bolt Hex 5/16-18 x 3 Gr. 5	211	532 12 01-83	Bearing Nylon
74	532 14 24-32	Screw 1/4 x 1/2	213	532 40 31-19	Knob Control Cruise
80	532 41 81-84	Strap Torque	214	532 41 68-63	Pedal Forward
92	874 76 05-20	Bolt 5/16-18 x 1/2	215	532 40 17-23	Pedal Reverse
99	532 41 81-88	Spring Bypass	220	532 19 89-08	Reflector RH
114	873 80 05-00	Nut Lock Hex W/Ins. 5/16-18 unc	221	532 40 31-87	Retainer Spring Clip Handle
116	873 90 05-00	Nut Lock Hex Flange 5/16-18	222	879 21 20-10	Washer 21/32 x 1-1/4 x 10 Ga.
121	532 17 56-11	Bracket Strap Torque	284	532 41 76-93	Nut U-Chnl. 1/4-20
125	817 00 05-12	Screw 5/16-18 x 3/4	286	872 01 05-20	Bolt 5/16-18 x 2.50
145	532 16 31-68	Washer Axle Flange	307	874 18 04-12	Screw Mach 1/4-20 x 3/4

**NOTE:** All component dimensions given in U.S. inches  
1 inch = 25.4 mm



**TRACTOR - MODEL NO. GTH26V52LS (96043011802), PRODUCT NO. 960 43 01-18  
ENGINE**

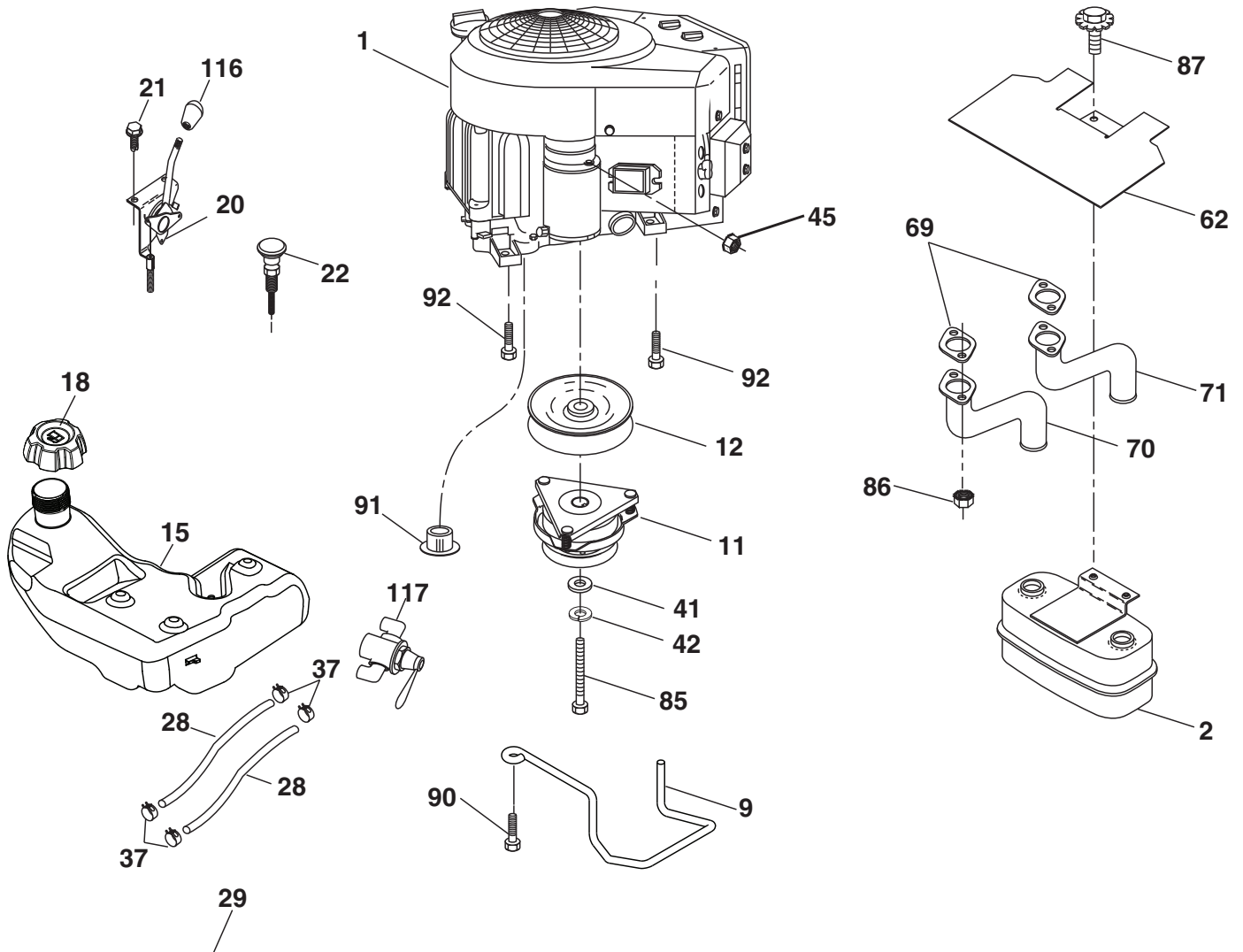

**SPARK ARRESTER KIT**

engine-tex\_Kawa-2cyl\_9

**TRACTOR - MODEL NO. GTH26V52LS (96043011802), PRODUCT NO. 960 43 01-18  
ENGINE**

<b>KEY NO.</b>	<b>PART NO.</b>	<b>DESCRIPTION</b>
1	---	Engine KAWA Model No. FR730V-AS04 (425016)(Ordr parts from engine manufacturer)
2	532 14 97-23	Muffler
9	532 40 86-67	Keeper Asm. Belt Engine
11	532 17 93-35	Clutch Electric
12	532 19 43-43	Pulley Engine
15	532 43 80-82	Tank Fuel
18	532 43 92-08	Cap Asm
20	532 42 43-41	Control Throttle
21	532 41 63-58	Screw #10 x 0.750 BOS Thread
22	532 19 15-96	Control Choke
28	532 40 11-35	Fuel Line
29	532 13 71-80	Spark Arrester Kit
37	532 12 34-87	Clamp Hose
41	532 12 61-97	Washer 1-1/2 OD x 15/32 ID x .250
42	810 04 07-00	Washer Lock 7/16
45	873 51 04-00	Nut Keps Hex 1/4-20 unc
62	532 43 40-17	Shield Heat Muffler
69	532 17 81-51	Gasket
70	532 42 47-65	Tube Exhaust LH
71	532 42 47-66	Tube Exhaust RH
85	532 17 99-53	Bolt 7/16-20 x 3.75 Gr. 5
86	532 18 43-62	Nut Hex M8-1.25
87	532 19 82-39	Bolt 5/16-18 unc x 1 w/Sems
90	817 00 06-16	Screw 3/8-16 x 1
91	532 18 74-95	Bushing
92	817 12 06-16	Screw 3/8-16 x 1
116	539 13 26-24	Knob Soft Touch
117	532 42 08-28	Valve Fuel Reserve

**NOTE:** All component dimensions given in U.S. inches  
1 inch = 25.4 mm

For engine service and replacement parts, call the toll  
free number for your engine manufacturer listed below:

Kawasaki                      1-949-460-5688

**TRACTOR - MODEL NO. GTH26V52LS (96043011802), PRODUCT NO. 960 43 01-18**  
**STEERING ASSEMBLY**

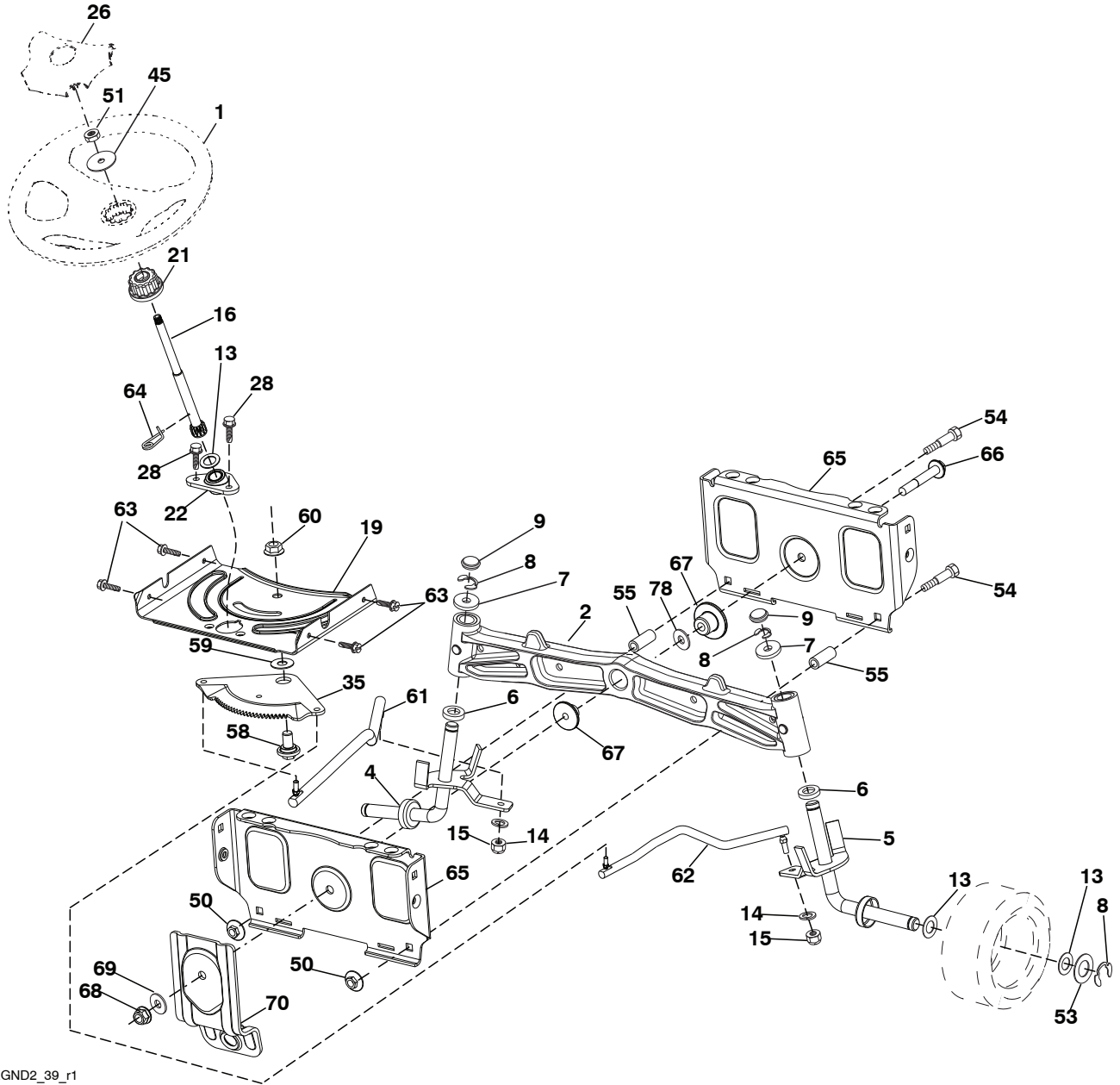

Steering-tex\_LEGND2\_39\_r1

**TRACTOR - MODEL NO. GTH26V52LS (96043011802), PRODUCT NO. 960 43 01-18  
STEERING ASSEMBLY**

<b>KEY NO.</b>	<b>PART NO.</b>	<b>DESCRIPTION</b>
1	532 43 97-40	Wheel, Steering
2	532 19 59-68	Axle Asm., Front
4	532 40 30-89	Spindle Asm. LH
5	532 40 30-90	Spindle Asm. RH
6	532 12 49-31	Bearing, Race Thrust Harden
7	532 12 17-48	Washer 25/32 x 1-5/8 x 16 Ga.
8	812 00 00-29	Ring, Clip #T5304-75
9	532 12 12-32	Cap, Spindle
13	532 12 17-49	Washer 25/32 x 1-1/4 x 16 Ga.
14	810 04 06-00	Washer, Lock Hvy Hlcl Spr 3/8
15	873 54 06-00	Nut, Crown Lock 3/8-24 unf
16	532 40 82-19	Shaft Steering
19	532 19 47-29	Plate Steering
21	532 18 67-37	Adapter, Wheel Steering
22	532 42 05-37	Steering Support Lower
26	532 43 97-43	Insert, Wheel Steering
28	817 00 06-12	Screw 3/8-16 x 3/4
35	532 19 47-32	Gear, Sector Plate
45	819 18 38-12	Washer 9/16 x 2-3/8 x 12 Ga.
50	873 90 06-00	Nut Lock Flange 3/8-16 unc
51	873 94 08-00	Nut Hex Jam Toplock 1/2-20 unf
53	532 18 89-67	Washer Hardened .793 x 1.637 x .060
54	874 76 06-36	Bolt Hex 3/8-16 unc x 2-1/4
55	532 41 47-36	Bolt Hex 3/8-16 unc x 2-1/4
58	532 19 47-47	Bolt Shoulder Sector Pivot CFM
59	532 19 47-48	Washer Thrust Sector Steering
60	873 97 10-00	Nut Flange Lock 5/8-11
61	532 19 47-40	Draglink, LH
62	532 19 47-41	Draglink, RH
63	817 00 05-12	Screw 5/16-18 x 3/4
64	532 19 98-49	Retainer Clip Spring Steering
65	532 19 47-34	Brace Axle Front
66	871 02 07-48	Bolt Hex Fghd 7/16-14 x 3 Serr
67	532 19 47-37	Bushing PM Front Axle
68	873 90 07-00	Nut Lock Flange 7/16-14 Gr. 5
69	532 19 91-62	Washer 1.5 x .505 x .118
70	532 19 61-97	Bracket Deck Susp. Front
78	532 05 70-79	Washer Thrust

**NOTE:** All component dimensions given in U.S. inches  
1 inch = 25.4 mm

**TRACTOR - MODEL NO. GTH26V52LS (96043011802), PRODUCT NO. 960 43 01-18  
MOWER DECK**

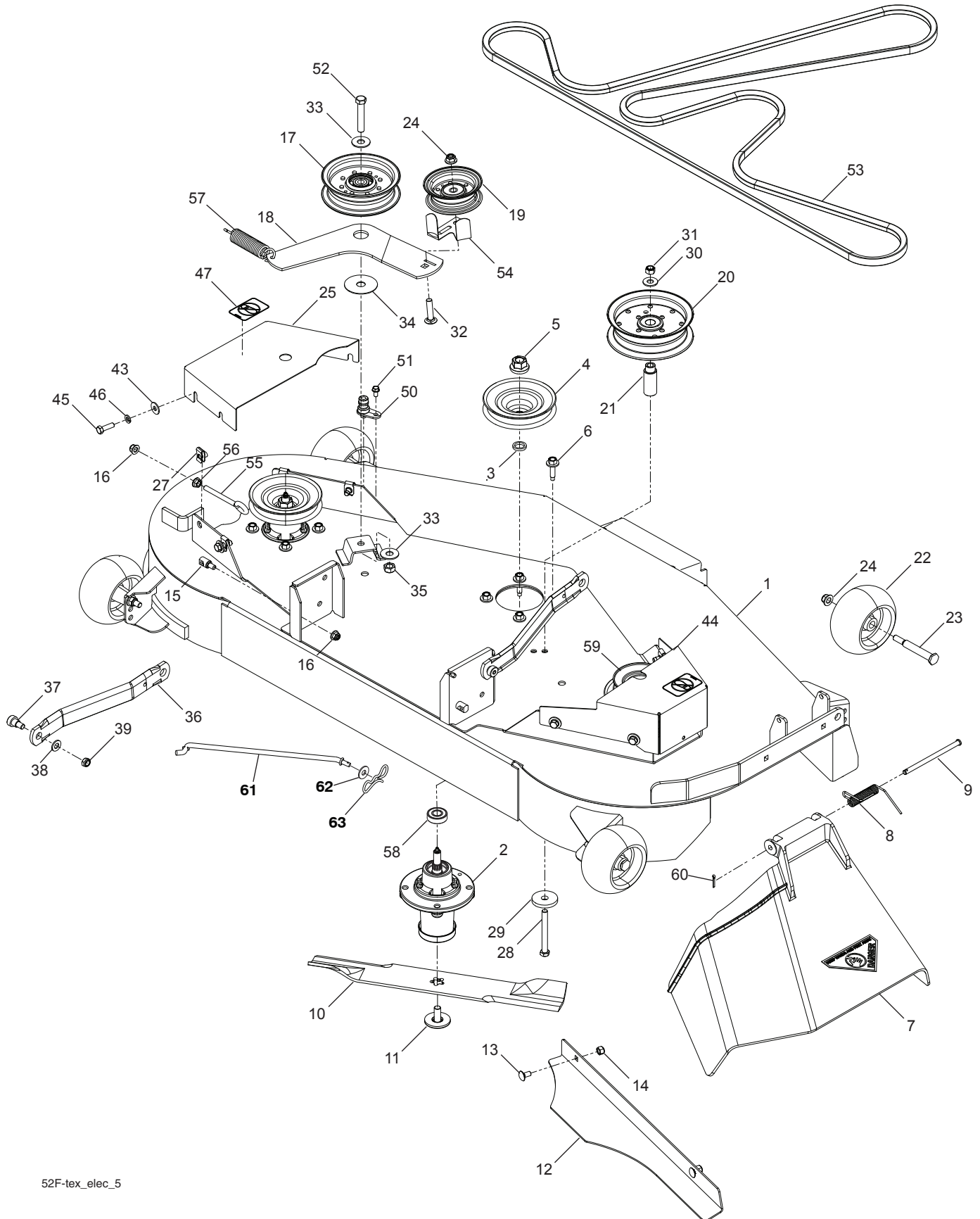

52F-tex\_elec\_5

**TRACTOR - MODEL NO. GTH26V52LS (96043011802), PRODUCT NO. 960 43 01-18  
MOWER DECK**

KEY NO.	PART NO.	DESCRIPTION	KEY NO.	PART NO.	DESCRIPTION
1	575 43 80-03	Deck w/ Decals 52"	33	539 10 48-64	Washer, 7/16 Flat
2	539 11 21-70	Housing Assembly	34	532 17 85-15	Washer, Flat Hardened
3	532 18 76-90	Washer-Spacer	35	539 11 91-24	Nut, 7/16-14 Hex Nyloc
4	532 10 75-21	Pulley, Mandrel	36	532 19 51-85	Arm, Susp., Rear
5	532 40 02-34	Nut, 9/16 Top Center Lock	37	539 11 36-21	Sb 3/8-16 x 3/8 Skt Hd
6	539 10 76-30	Screw, Washer Head	38	539 99 01-22	Washer, 3/8 Sae Flt
7	532 11 07-33	Discharge Chute, 52"	39	539 20 02-82	Nut, 3/8-16 Hex Jam Nyloc
8	532 11 07-35	Spring - Torsion	43	539 99 06-92	Washer, 5/16 Std Flt
9	532 11 07-36	Pin, Clevis 5/16 x 5.19	44	575 32 00-02	Shield, Belt RH
10	574 87 08-01	Blade, 16-1/4"	45	539 99 02-09	Hcs 5/16-18 x 1 Gr 5
11	539 10 75-22	Bolt, 7/16, Assy Blade	46	539 99 01-87	Wash 5/16 Slw
12	574 87 50-02	Confinement Plate	47	539 10 57-43	Decal, No Step
13	539 99 07-99	Rhsnb 5/16-18 x 5/8 Gr 5	50	532 41 55-98	Washout Port
14	539 99 07-17	Nut 5/16-18 Hex Nyloc	51	539 10 84-61	Bolt, 1/4-20 x 1/2
15	532 19 51-61	Stud, Fasten w/ Anti- Rotate	52	539 10 48-70	Hcs 7/16-14 x 2-1/2 Gr 5
16	539 11 28-99	Nut 5/16-18 Hex Flange Nyloc	53	574 84 56-03	Belt, Deck
17	532 19 61-04	Pulley, Idler Spec. Hub	54	575 22 43-01	Guard, Belt
18	574 84 18-02	Arm, Idler, Blk	55	539 11 55-74	Eyebolt 5/16 x 3-1/2
19	532 17 79-68	Pulley, Idler	56	539 99 05-85	Nut 5/16-18 Hex Whizlk
20	539 13 27-28	Pulley, Idler	57	539 10 68-50	Spring
21	575 22 45-01	Idler Bushing	58	539 11 20-50	Ball Bearing
22	539 10 76-10	Wheel, Gauge	59	575 35 29-01	Pulley
23	539 19 34-06	Bolt, Shoulder	60	532 16 94-84	Clip Retainer
24	521 99 65-01	Nut 3/8-16 Hex Flg Nyloc	61	532 40 48-51	Rod Anti-Sway
25	575 22 47-02	Shield, Belt LH	62	819 13 13-12	Washer 13/32 x 13/16 x 12 Ga.
27	539 10 47-63	Retainer 5/16c U Type	63	532 19 42-08	Pin Cotter 5/16 Bow Tie Lock
28	539 10 82-71	Hcs 3/8-16 x 3-1/2 Gr 5	--	574 80 42-01	Mower Deck Complete
29	539 10 65-04	Heavy Washer			
30	539 99 05-17	Washer, 3/8 Flat Std			
31	539 97 69-79	Nut 3/8-16 Hex Nyloc			
32	539 99 09-23	Rhsnb 3/8-16 x 1-3/4 Gr 5			

**NOTE:** All component dimensions given in U.S. inches  
1 inch = 25.4 mm

**TRACTOR - MODEL NO. GTH26V52LS (96043011802), PRODUCT NO. 960 43 01-18  
MOWER LIFT**

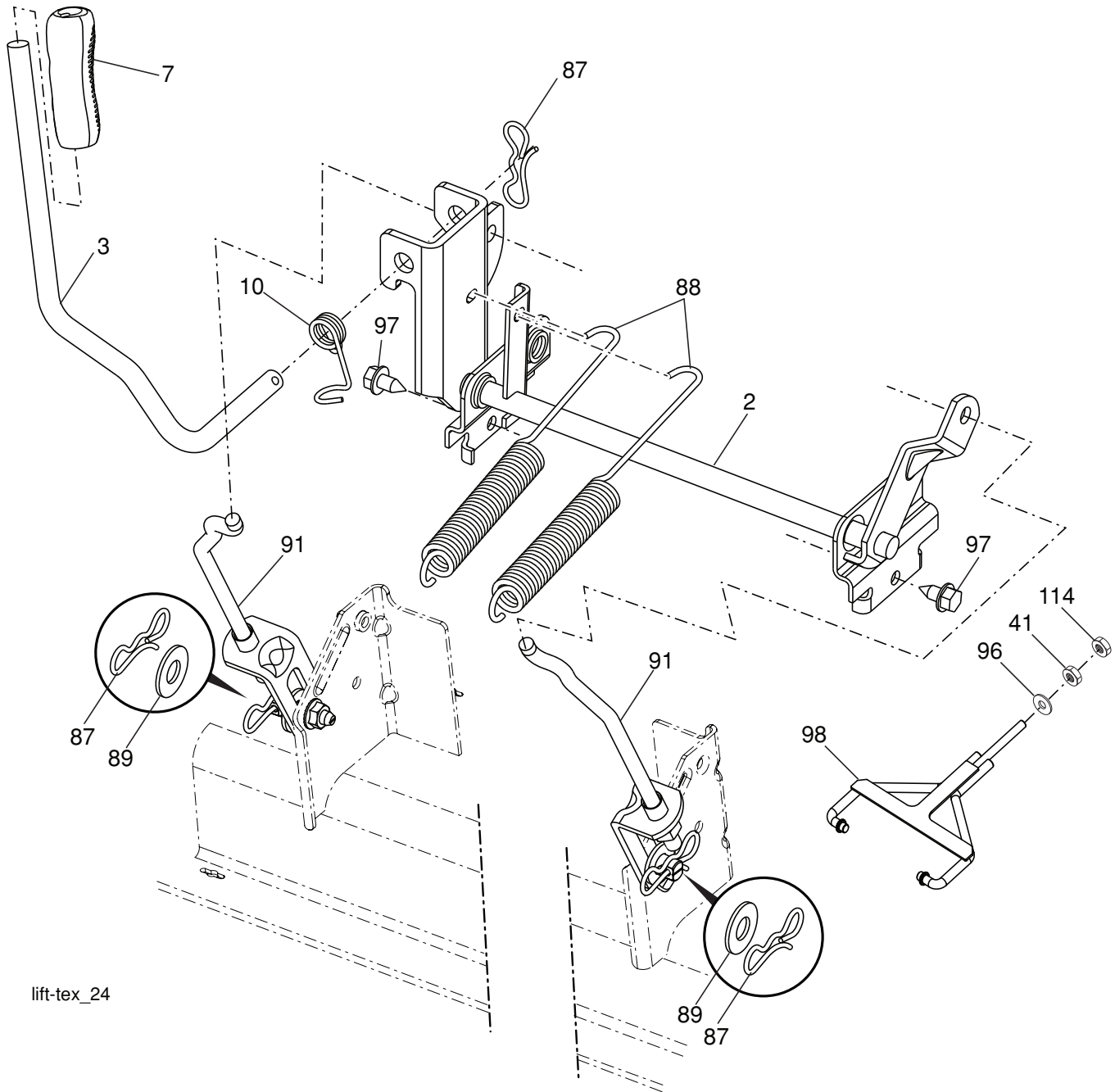

lift-tex\_24

KEY NO.	PART NO.	DESCRIPTION
2	532 42 20-27	Shaft Asm., Lift
3	532 19 52-30	Lever Asm., Lift RH
7	532 41 15-55	Grip, Lever
10	532 19 63-14	Spring Torsion
41	532 17 59-94	Nut Lift Link
87	532 19 42-09	Pin Cotter 7/16 Bow Tie Lock
88	532 19 53-04	Spring Lift Assist
89	819 19 19-12	Washer Clear Zinc

KEY NO.	PART NO.	DESCRIPTION
91	532 40 34-07	Link Lift Susp Mower Rear
96	532 19 52-63	Bushing Spherical
97	817 00 06-12	Screw 3/8-16 x .75
98	574 82 25-01	Link Lift Susp. Front Mower
114	873 36 07-00	Nut Jam 7/16-20

**NOTE:** All component dimensions given in U.S. inches  
1 inch = 25.4 mm



# TRACTOR - MODEL NO. GTH26V52LS (96043011802), PRODUCT NO. 960 43 01-18 SEAT ASSEMBLY

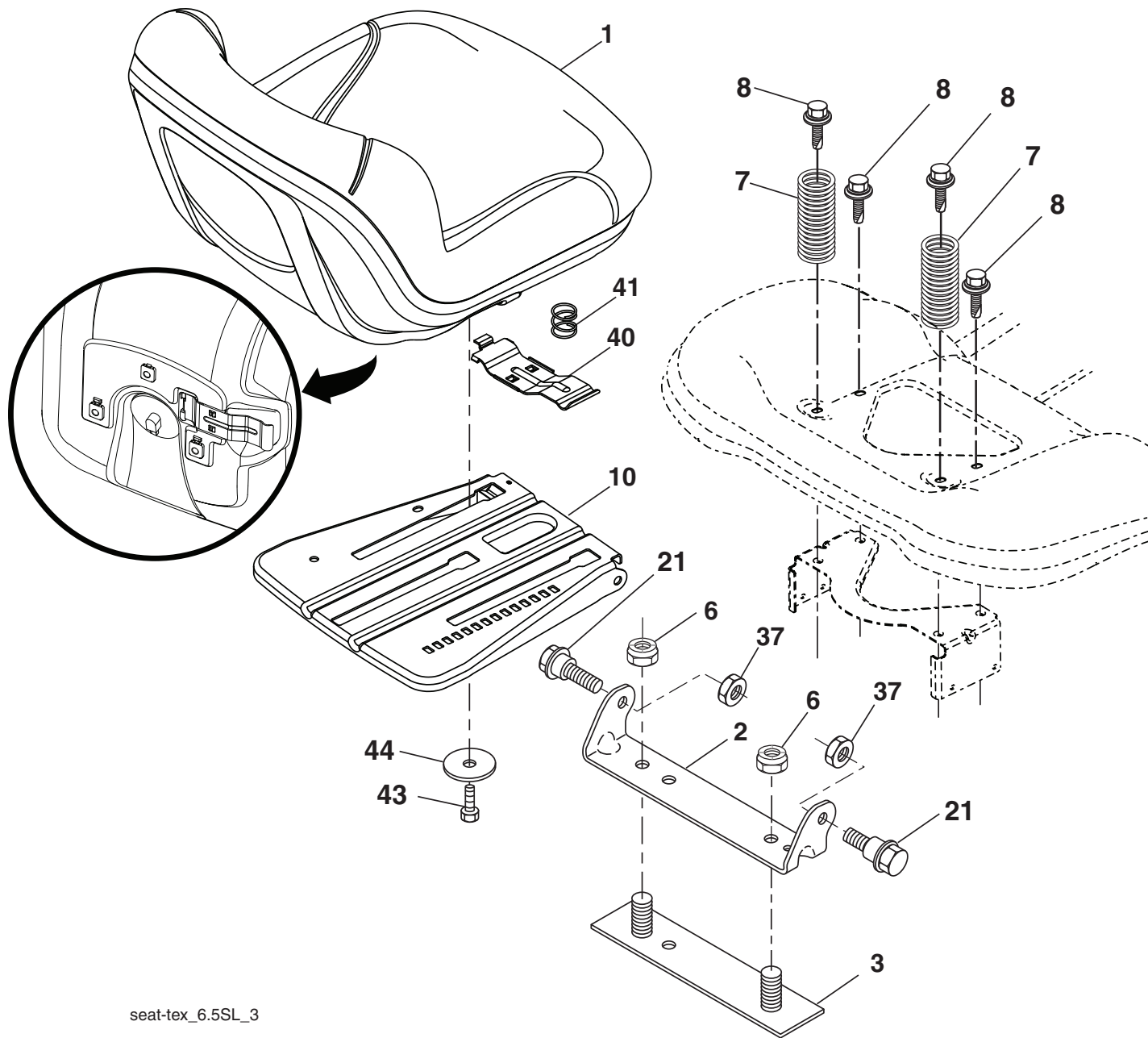

seat-tex\_6.5SL\_3

KEY NO.	PART NO.	DESCRIPTION
1	532 42 40-73	Seat
2	532 18 01-66	Bracket Pivot Fender
3	532 14 06-75	Strap, Asm Fender
6	873 80 06-00	Nut, Lock w/Ins. 3/8-16 unc
7	532 12 41-81	Spring, Seat Cprsn
8	532 17 18-77	Bolt 5/16-18 unc x 3/4 w/Sems
10	532 19 69-77	Pan, Seat
21	532 17 18-52	Bolt, Shoulder 5/16-18

KEY NO.	PART NO.	DESCRIPTION
37	873 80 05-00	Nut, Lock 5/16-18 unc
40	532 19 76-61	Handle Slide Seat
41	532 19 82-00	Spring Latch Seat
43	874 76 06-12	Bolt Fin Hex 3/8-16 unc x 3/4
44	819 13 38-12	Washer 13/32 x 2-3/8 x 12 Ga.

**NOTE:** All component dimensions given in U.S. inches  
1 inch = 25.4 mm

**TRACTOR - MODEL NO. GTH26V52LS (96043011802), PRODUCT NO. 960 43 01-18  
DECALS**

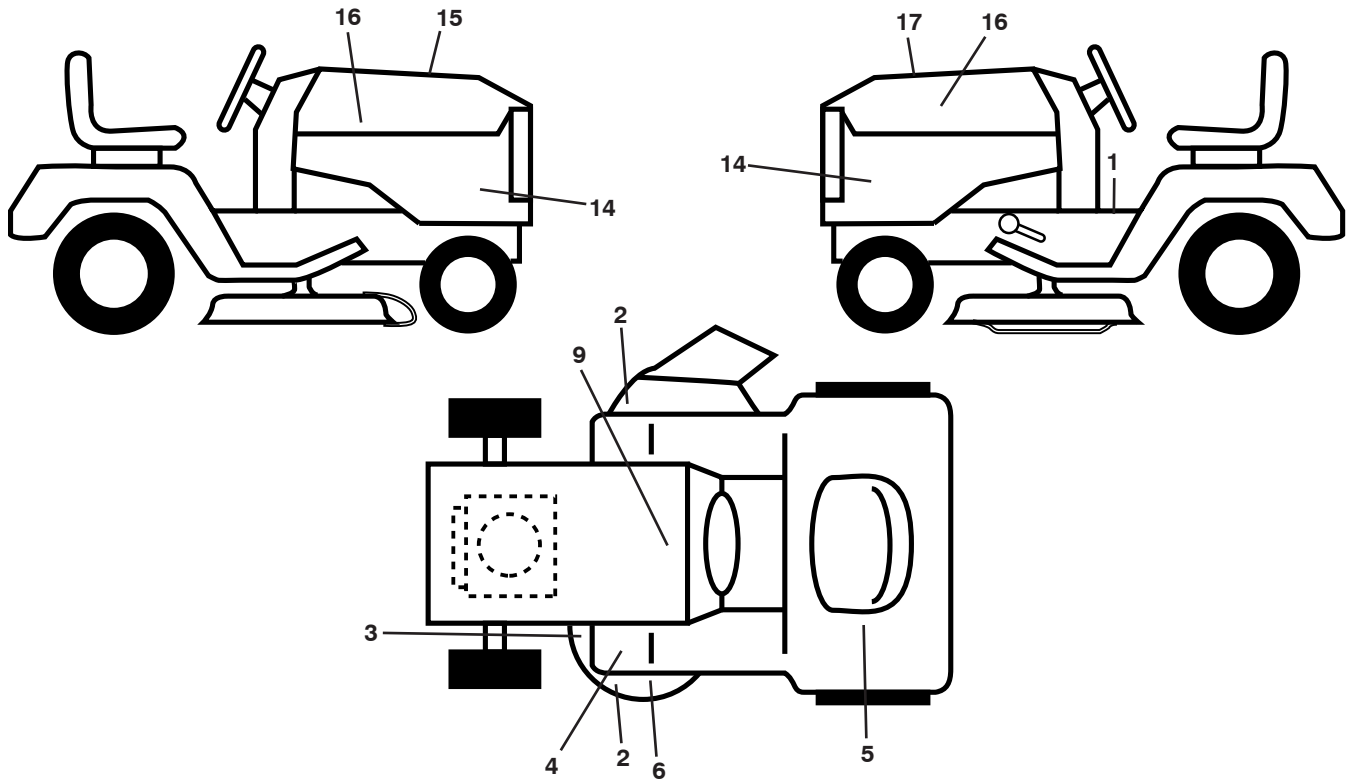

KEY NO.	PART NO.	DESCRIPTION
1	532 41 16-57	Decal, Operator's
2	539 10 57-43	Decal, No Step
3	532 19 87-85	Decal, Mower
4	532 41 86-00	Decal, Pedal
5	532 42 62-09	Decal, Warning Reserve
6	539 11 32-24	Decal, Warning
9	532 14 50-05	Decal, Battery Dnge/Poi
14	532 44 03-90	Decal, Panel Side

KEY NO.	PART NO.	DESCRIPTION
15	532 42 38-29	Decal, Cust. Resp.
16	532 42 91-96	Decal, Hood Logo
17	532 43 96-67	Decal, Replacement
--	532 16 69-60	Decal, Bypass
--	532 43 98-82	Pad, Footrest, LH
--	532 43 98-81	Pad, Footrest, RH
--	532 44 46-96	Manual, Owner's (Eng)
--	532 44 47-00	Manual, Owner's (Span)

**WHEELS AND TIRES**

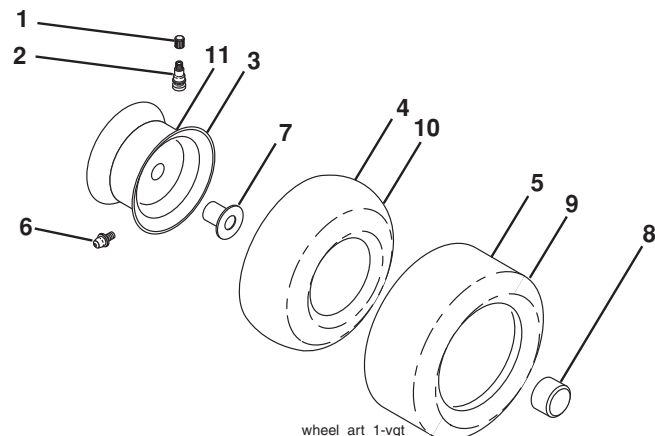

KEY NO.	PART NO.	DESCRIPTION
1	532 05 91-92	Cap, Valve, Tire
2	532 06 51-39	Stem, Valve
3	532 18 18-39	Rim Assembly, Front
4	532 00 81-34	Tube, Front (Service Item Only)
5	532 16 10-24	Tire, Front
6	532 12 49-57	Fitting, Grease (Front Wheel Only)
7	532 12 49-59	Bearing, Flange (Front Wheel Only)
8	532 17 50-39	Cap, Axle (Front Wheel Only)
9	532 17 04-53	Tire, Rear
10	532 00 71-54	Tube, Rear (Service Item Only)
11	532 14 45-10	Rim Assembly, Rear
--	532 14 43-34	Sealant, Tire (10 oz. Tube)

**NOTE:** All component dimensions given in U.S. inches  
1 inch = 25.4 mm

---

# SERVICE NOTES

---

---

# SERVICE NOTES

---

# SUGGESTED GUIDE FOR SIGHTING SLOPES FOR SAFE OPERATION

