

# YTH21K46

---

## ILLUSTRATED PARTS LIST

**Gasoline containing up to 10% ethanol (E10) is acceptable for use in this machine.  
The use of any gasoline exceeding 10% ethanol (E10) will void the product warranty.**

# TRACTOR - - MODEL NUMBER YTH21K46 (96045002901), PRODUCT NO. 960 45 00-29 SCHEMATIC

SCH10

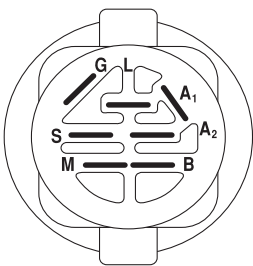
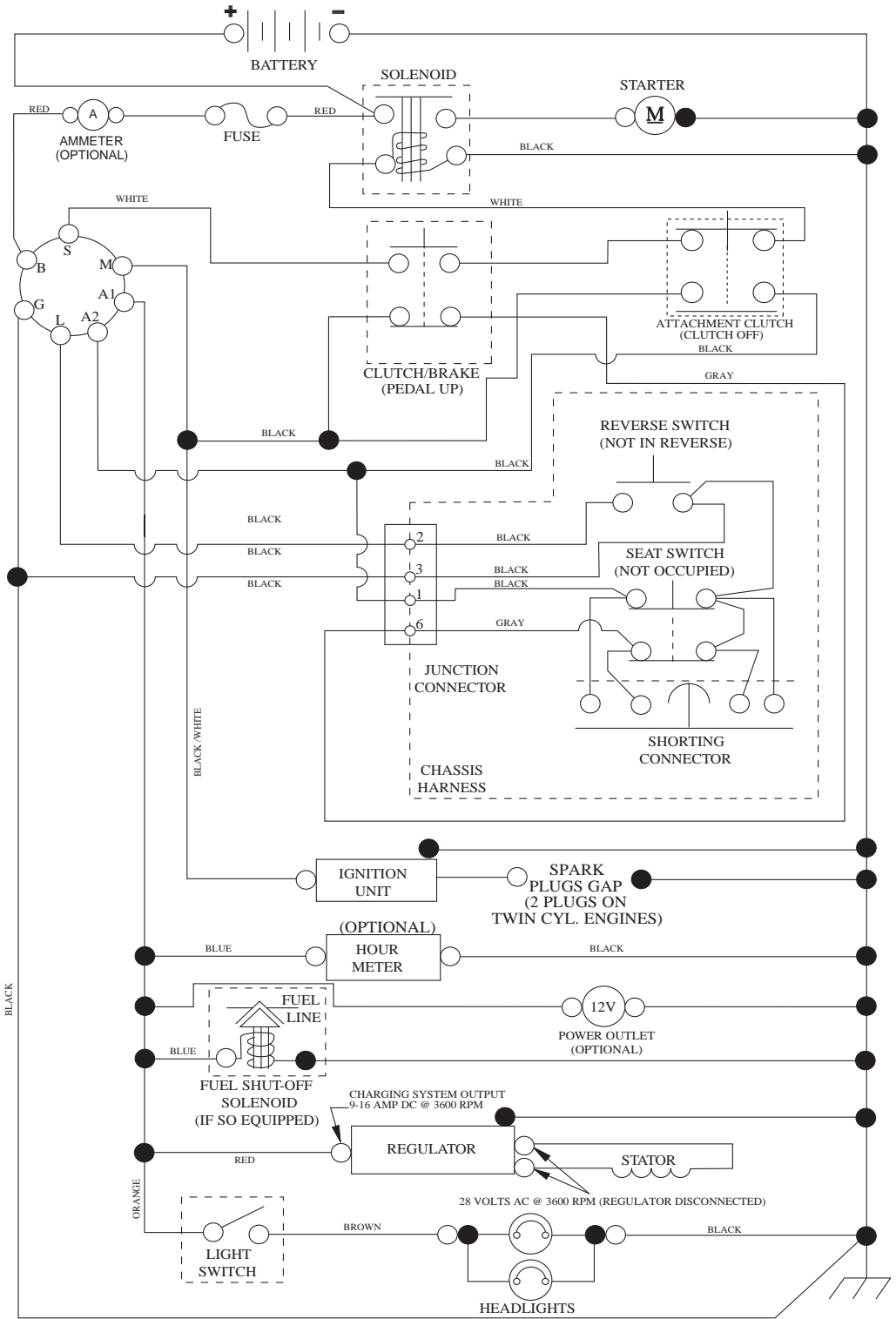

IGNITION SWITCH

POSITION	CIRCUIT	"MAKE"
OFF	M+G+A1	
RUN/OVERRIDE	B+A1	
RUN	B+A1	L+A2
START	B + S + A1	

03107

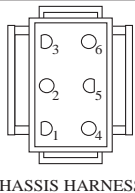

CHASSIS HARNESS CONNECTOR (MATING SIDE)

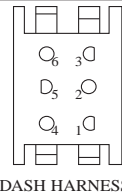

DASH HARNESS CONNECTOR (MATING SIDE)

WIRING INSULATED CLIPS  
NOTE: IF WIRING INSULATED CLIPS WERE REMOVED FOR SERVICING OF UNIT, THEY SHOULD BE RE-INSTALLED TO PROPERLY SECURE YOUR WIRING.

NON-REMOVABLE CONNECTIONS

REMOVABLE CONNECTIONS

**TRACTOR - - MODEL NUMBER YTH21K46 (96045002901), PRODUCT NO. 960 45 00-29  
ELECTRICAL**

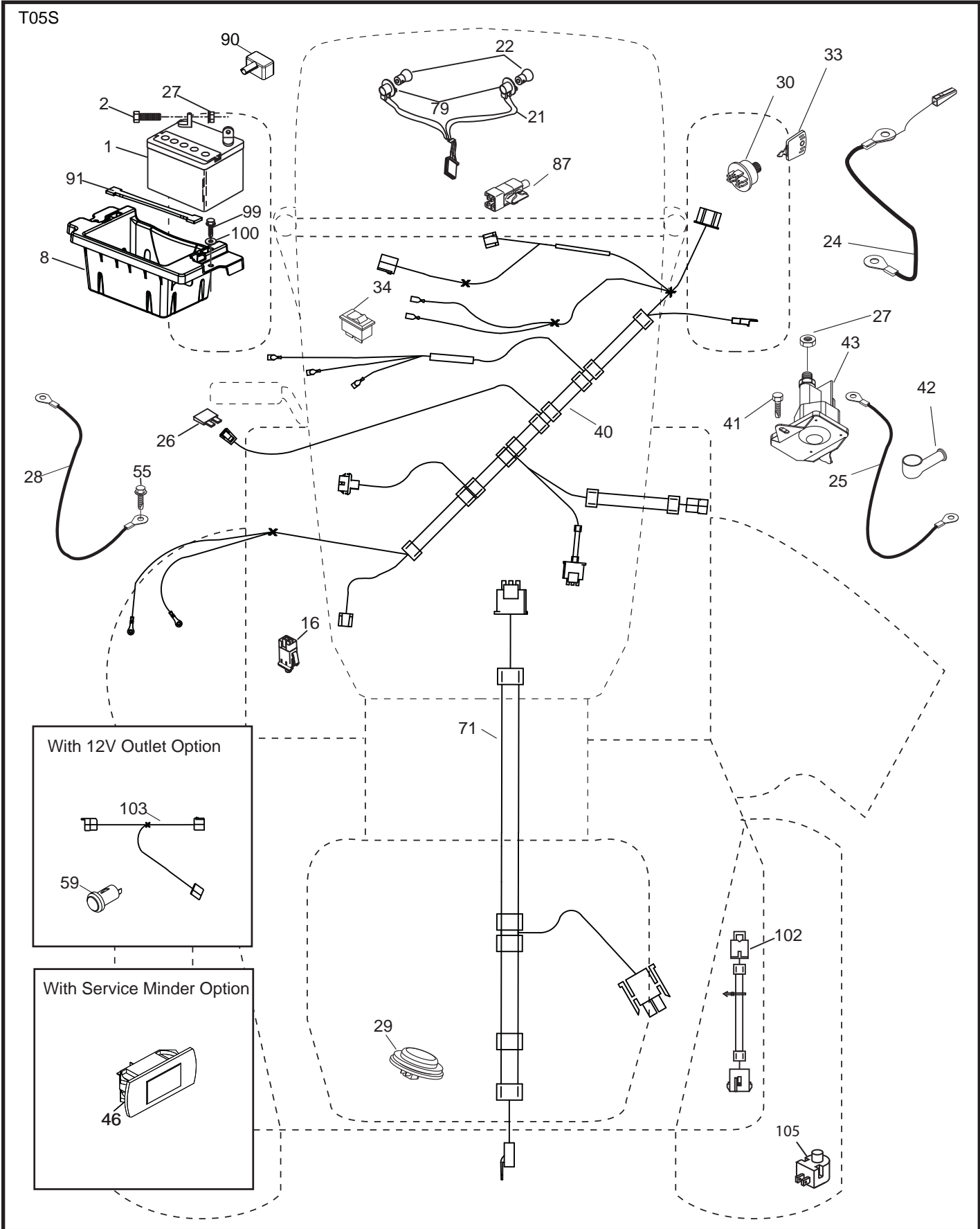

**TRACTOR - - MODEL NUMBER YTH21K46 (96045002901), PRODUCT NO. 960 45 00-29  
ELECTRICAL**

<b>KEY NO.</b>	<b>PART NO.</b>	<b>DESCRIPTION</b>
1	532 16 34-65	Battery
2	874 76 04-12	Bolt Hex Head 1/4-20 x 3/4
8	532 41 41-25	Box Battery
16	532 17 61-38	Switch Interlock Push-In
21	532 40 02-52	Harness Socket Light w/4152J
22	532 00 41-52	Bulb Light
24	532 40 02-53	Cable BTRY.
25	532 41 28-95	Cable Starter
26	532 17 51-58	Fuse
27	873 51 04-00	Nut Keps Hex 1/4-20 unc
28	532 14 54-91	Cable, Ground
29	532 40 15-45	Switch, Seat
30	532 19 33-50	Switch, Ign
33	532 41 19-33	Key/Chain
34	532 11 07-12	Switch Light/Reset
40	532 40 10-98	Harness Ign. Dash
41	817 72 04-08	Screw Thd Cut 1/4-20 x 1/2
42	532 13 15-63	Cover, Terminal
43	532 19 25-07	Solenoid
46	532 40 17-63	Gauge Serviceminder Hrmtr
55	817 06 05-12	Screw Thdrol 5/16-18 x 3/4 TYTT
71	532 19 42-76	Harness Chassis
79	532 17 52-42	Socket Asm. Bulb
87	532 19 78-02	Switch Interlock
90	532 43 53-95	Cover Terminal
91	532 19 02-70	Strap Battery
99	817 67 04-12	Screw 1/4-20 x 4
100	819 09 14-16	Washer 9/32 x 7/8 x 16 Ga.
102	532 40 44-54	Harness Pigtail
105	532 40 75-68	Switch Reverse

**NOTE:** All component dimensions given in U.S. inches  
1 inch = 25.4 mm

**TRACTOR - - MODEL NUMBER YTH21K46 (96045002901), PRODUCT NO. 960 45 00-29  
CHASSIS**

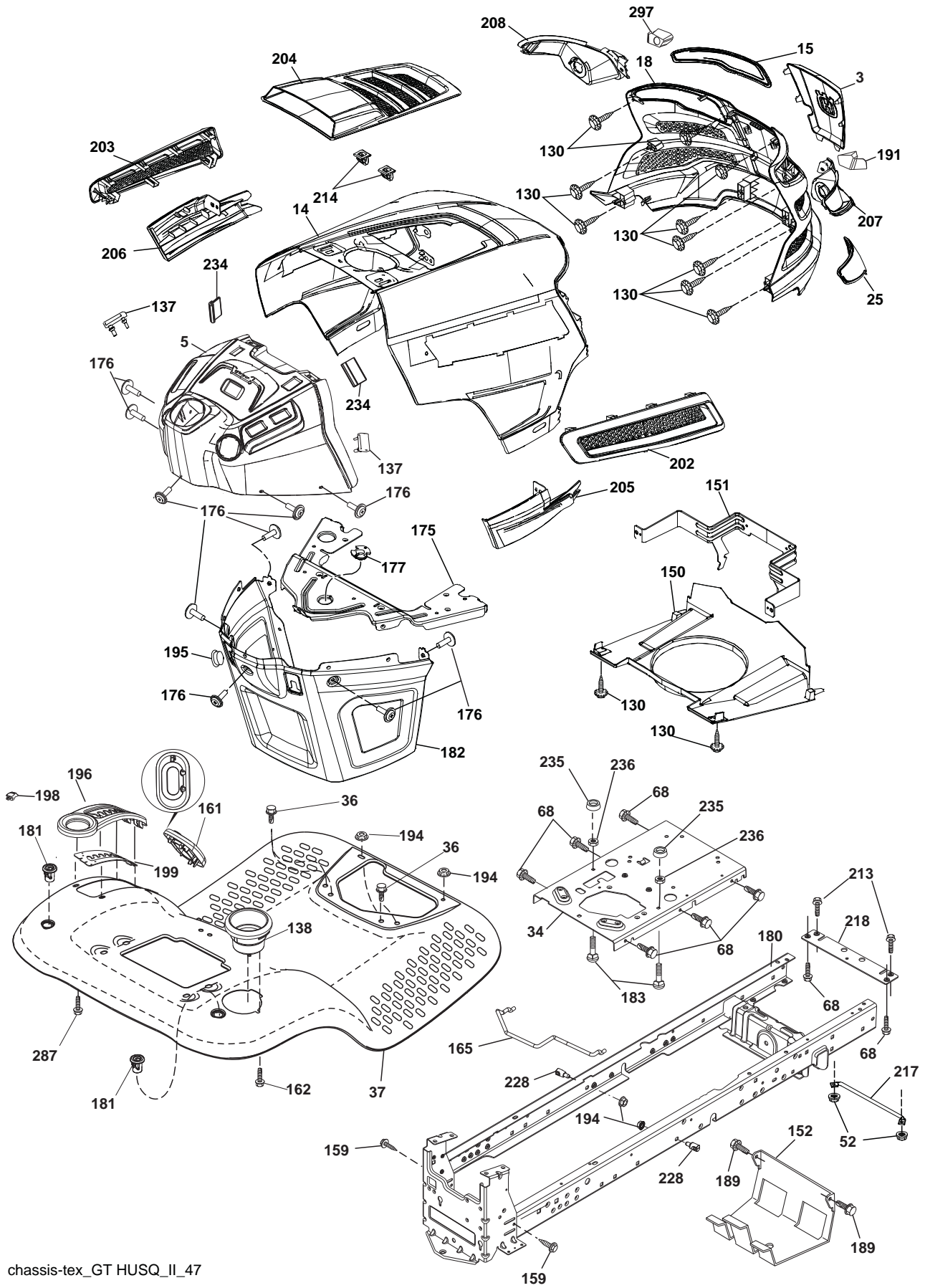

chassis-tex\_GT HUSQ\_II\_47

**TRACTOR - - MODEL NUMBER YTH21K46 (96045002901), PRODUCT NO. 960 45 00-29  
CHASSIS**

<b>KEY NO.</b>	<b>PART NO.</b>	<b>DESCRIPTION</b>	<b>KEY NO.</b>	<b>PART NO.</b>	<b>DESCRIPTION</b>
3	532 43 97-52	Logo	189	817 00 05-12	Screw 5/16-18 x 3/4
5	532 43 74-73	Dash	191	532 43 74-55	Insert Reflective RH
14	532 44 11-77	Hood	194	873 90 05-00	Nut Lock Hex Flange 5/16-18
15	532 43 97-33	Lens LH	195	532 40 41-37	Plug Hole Dash Lower
18	532 43 77-62	Grille	196	532 43 96-47	Console Asm. Deck Lift
25	532 44 33-85	Lens RH	198	532 44 15-52	Deck Indicator
34	532 19 61-25	Plate Engine	199	532 41 34-85	Deck Lift Plate
36	817 06 05-12	Screw 5/16-18 x 3/4	202	532 43 97-28	Vent Side Hood RH
37	532 44 12-69	Fender	203	532 43 97-27	Vent Side Hood LH
52	873 68 05-00	Nut Lock 5/16-18	204	532 43 57-14	Vent Top Hood
68	817 49 05-08	Screw Thdrol 5/16-18 x 1/2	205	532 43 97-30	Skirt Hood Side RH
130	532 41 63-58	Screw #10 x 0.750	206	532 43 97-29	Skirt Hood Side LH
137	532 40 75-90	Bumper Dash	207	532 43 97-34	Bezel RH
138	532 43 97-47	Cupholder	208	532 43 97-35	Bezel LH
150	532 43 97-31	Air Duct	213	874 76 05-12	Bolt 5/16-18 x 3/4
151	532 43 66-70	Bracket Pivot	214	532 19 91-45	Clip Retainer Tinner
152	532 19 95-35	Shield Browning	217	532 40 91-67	Rod Pivot
159	817 00 06-12	Screw Hexwsh Thrd 3/8-16 x 3/4	218	532 19 63-95	X-Piece Hood Stop
161	532 43 97-81	Fuel Window	228	532 19 51-61	Stud Fastner
162	532 14 24-32	Screw	234	532 40 47-42	Bumper Hood
165	532 19 68-26	Support Tank Rear	235	532 40 61-29	Spacer Fender
175	532 19 63-04	Crossmember	236	873 93 05-00	Nut Lock 5/16-18 unc
176	532 40 07-76	Screw 10-24 x 5/8	287	817 60 04-06	Screw 1/4-20 x 3/8
177	532 19 52-27	Bushing Steering	297	532 43 74-56	Insert Reflective LH
180	532 19 54-57	Chassis			
181	532 43 97-46	Bushing Mtg. Fender Crgo			
182	532 40 68-59	Dash Lower			
183	874 52 05-20	Bolt 5/16-18 x 1-1/4			

**NOTE:** All component dimensions given in U.S. inches  
1 inch = 25.4 mm

TRACTOR - - MODEL NUMBER YTH21K46 (96045002901), PRODUCT NO. 960 45 00-29  
DRIVE

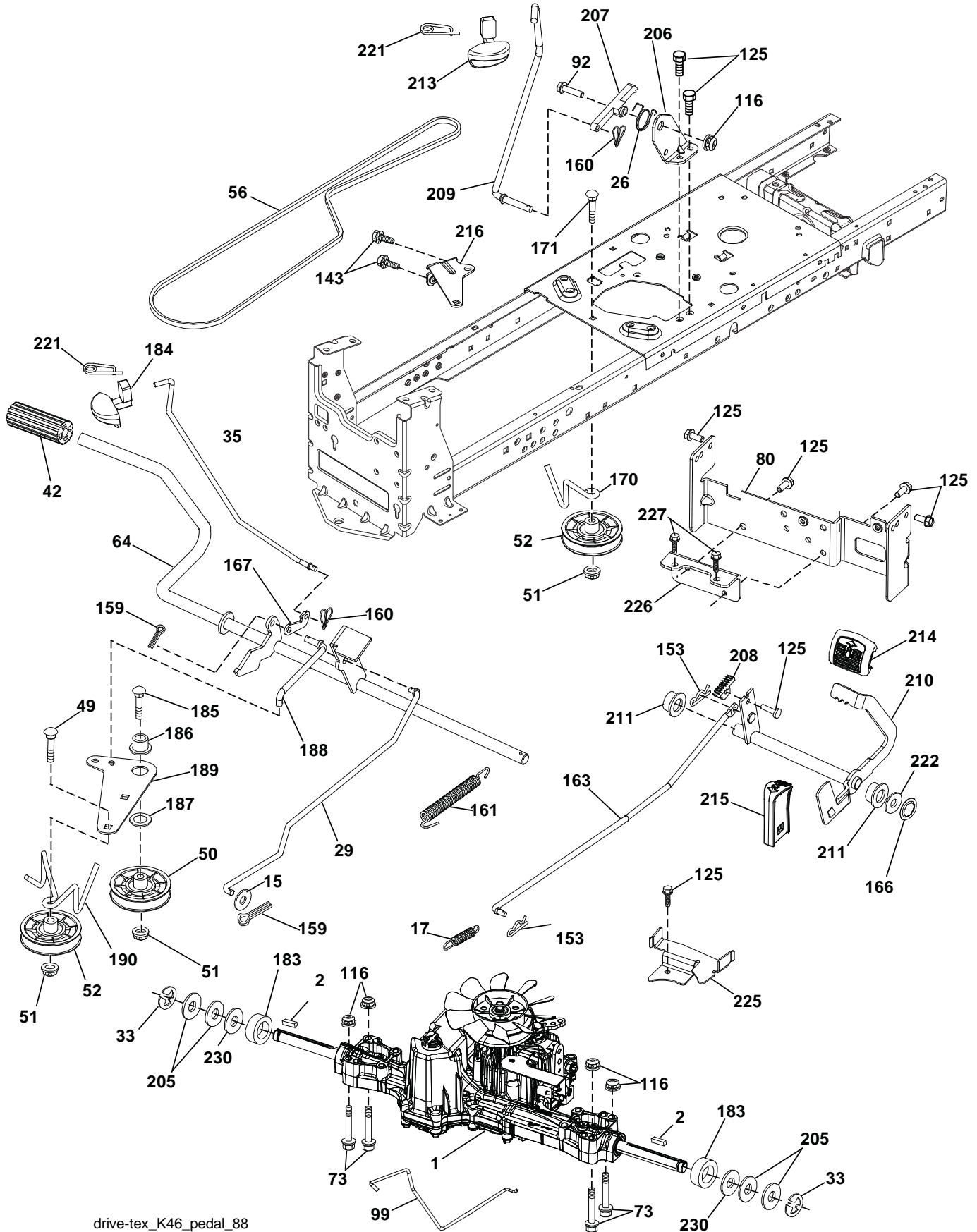

drive-tex\_K46\_pedal\_88



**TRACTOR - - MODEL NUMBER YTH21K46 (96045002901), PRODUCT NO. 960 45 00-29  
DRIVE**

KEY NO.	PART NO.	DESCRIPTION	KEY NO.	PART NO.	DESCRIPTION
1	-----	Transaxle, TUFFTORQ K46BT (426120) (Order parts from transaxle manufacturer)	170	532 19 43-22	Keeper V-Idler
2	532 12 35-83	Key Square	171	872 11 06-16	Bolt 3/8-16 unc x 2
15	819 13 13-16	Washer 13/32 x 13/16 x 16 Ga.	183	532 13 70-57	Spacer Axle
17	532 41 36-78	Spring, Brake	184	532 44 14-55	Handle Parking Brake
26	532 19 96-79	Spring Return Cruise	185	872 11 06-22	Bolt
29	532 40 38-06	Rod, Brake	186	532 19 43-21	Spacer Retainer
33	812 00 00-01	Ring E	187	819 13 32-10	Washer
35	532 43 54-86	Rod, Brake, Park	188	532 19 43-23	Link Clutch Ground Drive
42	532 12 48-72	Cover, Foot Pedal	189	532 19 43-17	Bellcrank Ground Drive
49	872 11 06-14	Bolt	190	532 19 43-18	Keeper Bellcrank Ground Drive
50	532 19 43-27	Pulley Idler Flat	205	532 12 17-48	Washer 25/32 x 1-5/8 x 16 Ga.
51	873 90 06-00	Lock Nut 3/8-16	206	532 19 78-67	Bracket Mount Latch Cruise
52	532 19 43-26	Idler V-Groove 910" Offset	207	532 19 78-68	Latch Control Cruise
56	532 13 09-69	V-Belt, Drive	208	532 19 78-69	Gear Sector Control Cruise
64	532 19 78-65	Shaft Asm. Pedal Brake Control	209	532 19 95-92	Rod Control Cruise
73	874 49 05-44	Bolt Hex 5/16-18 x G.5	210	532 40 09-80	Rocker Asm. Pedal Control
80	532 44 06-19	Strap Torque	211	532 12 01-83	Bearing Nylon
92	874 76 05-20	Bolt Fin Hex 5/16-18 unc x 1.25	213	532 40 31-19	Knob Control Cruise
99	532 41 57-42	Rod Spring Bypass	214	532 42 12-63	Pedal Forward
116	873 90 05-00	Nut Lock Hex Flange 5/16-18	215	532 40 17-23	Pedal Reverse
125	817 00 05-12	Screw 5/16-18 x 3/4	216	532 19 61-31	Bracket Pulley Idler
143	817 49 05-08	Screw 5/16-18 x 1/2	221	532 40 31-87	Retainer Spring Clip Handle
153	532 12 47-88	Retainer Spring 1"	222	879 21 20-10	Washer 21/32 x 1-1/4 10 Ga.
159	876 02 04-12	Pin Cotter 1/8 x 3/4	225	532 40 33-19	Keeper Belt Transaxle
160	532 16 94-84	Retainer Clip	226	532 40 15-64	Bracket Strap Torque
161	532 10 57-09	Spring, Return, Clutch	227	817 49 05-12	Screw 5/16-18 x 3/4
163	532 40 10-34	Rod Control	230	532 18 89-67	Washer .793 x 1.637 x 060
166	532 42 91-64	Nut Push			
167	532 40 52-57	Latch Brake Parking			

**NOTE:** All component dimensions given in U.S. inches  
1 inch = 25.4 mm



TRACTOR - - MODEL NUMBER YTH21K46 (96045002901), PRODUCT NO. 960 45 00-29  
ENGINE

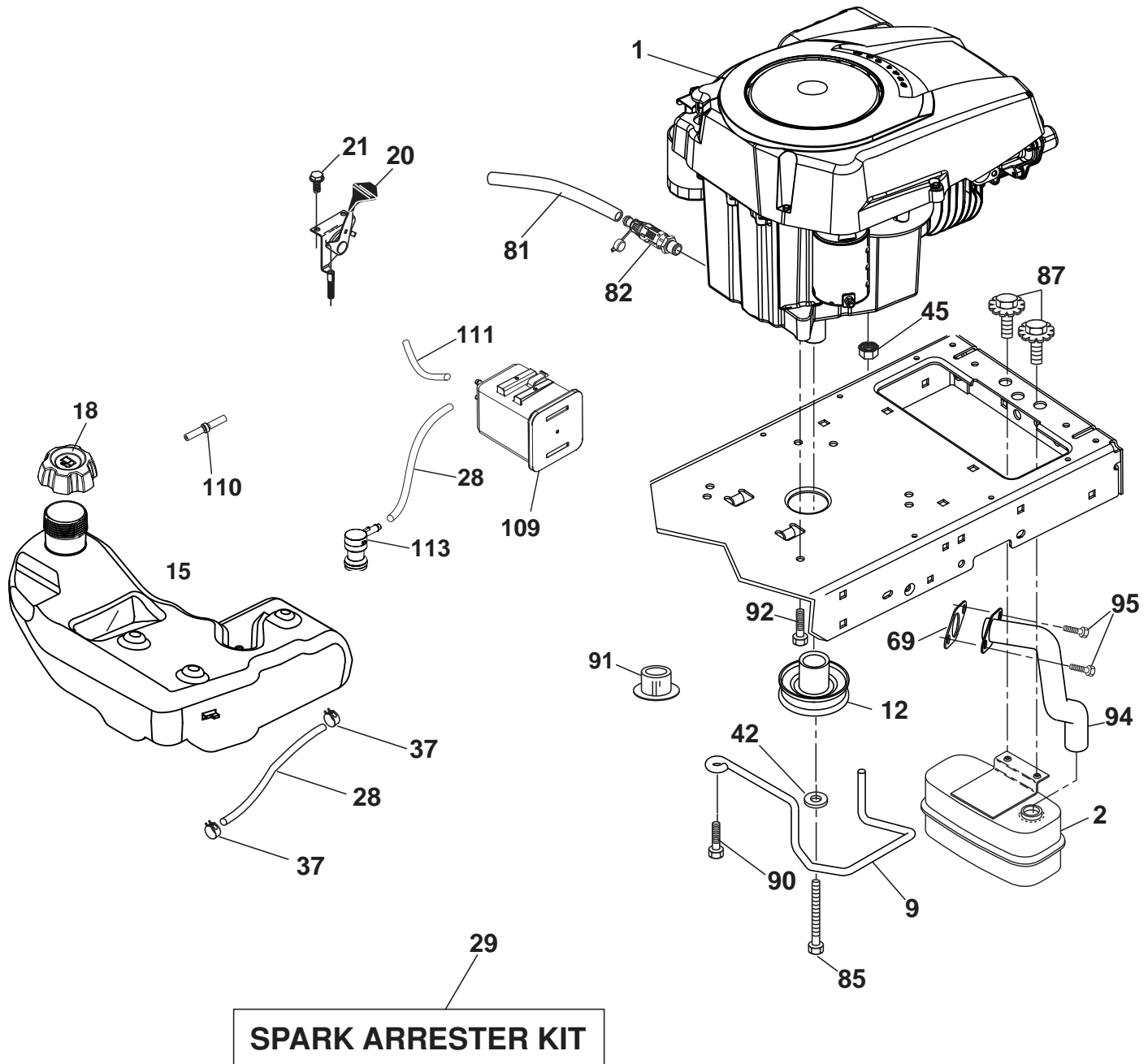

engine-tex\_Kohl\_35

**TRACTOR - - MODEL NUMBER YTH21K46 (96045002901), PRODUCT NO. 960 45 00-29  
ENGINE**

<b>KEY NO.</b>	<b>PART NO.</b>	<b>DESCRIPTION</b>
1	-----	Engine Kohler Model No. SV610-3212 (430089)(Order parts from engine manufacturer)
2	532 18 86-55	Muffler
9	532 19 43-20	Keeper Belt Engine
12	532 40 54-72	Pulley Engine
15	532 41 41-51	Tank Fuel
18	532 43 92-08	Cap Asm
20	532 40 15-08	Control Throttle
21	532 41 63-58	Screw # 10 x 0.750
28	532 40 11-35	Fuel Line
29	532 13 71-80	Spark Arrester Kit
37	532 12 34-87	Clamp Hose
42	810 04 07-00	Washer Lock 7/16
45	873 51 04-00	Nut Keps Hex 1/4-20 unc
69	532 18 59-09	Gasket
81	532 14 84-56	Tube Drain Oil Easy
82	532 42 82-87	Valve Oil Drain
85	532 17 39-37	Bolt Hex 7/16-20 x 4 x Gr. 5-1.5 Thr
87	537 17 18-77	Bolt 5/16-18 unc x 3/4 w/Sems
90	817 00 06-16	Screw 3/8-16 x 1
91	532 18 74-95	Bushing
92	817 12 06-16	Screw 3/8-16 x 1
94	532 18 86-54	Tube Exhaust
95	532 19 23-34	Screw Socket Hd. 5/16-18 x .75
109	532 41 41-14	Canister Carbon Filter
110	532 41 41-18	Valve Asm. Anti-Slosh
111	532 41 41-19	Purge Line
113	532 41 41-27	Valve Slant Cartrdg.

**NOTE:** All component dimensions given in U.S. inches  
1 inch = 25.4 mm

For engine service and replacement parts, call the toll free number for your engine manufacturer listed below:

Kohler Co. 1-800-544-2444

**TRACTOR - - MODEL NUMBER YTH21K46 (96045002901), PRODUCT NO. 960 45 00-29**  
**STEERING ASSEMBLY**

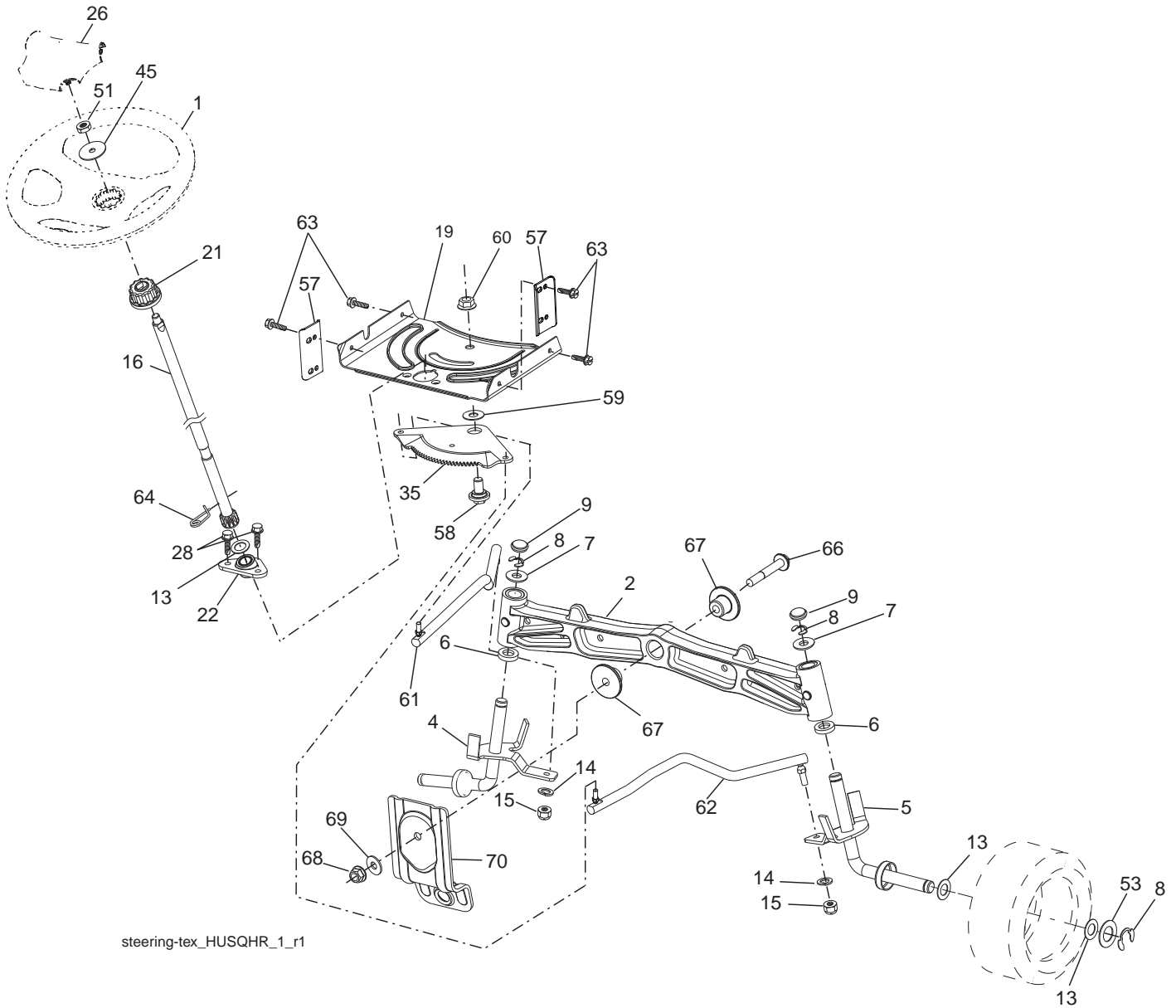

steering-tex\_HUSQHR\_1\_r1

**TRACTOR - - MODEL NUMBER YTH21K46 (96045002901), PRODUCT NO. 960 45 00-29  
STEERING ASSEMBLY**

<b>KEY NO.</b>	<b>PART NO.</b>	<b>DESCRIPTION</b>
1	532 43 97-40	Wheel, Steering
2	532 19 59-68	Axle Cast Iron
4	532 40 30-87	Spindle Asm., LH
5	532 40 30-88	Spindle Asm., RH
6	532 12 49-31	Washer, Thrust
7	532 12 17-48	Washer 25/32 x 1-5/8 x 16 Ga.
8	812 00 00-29	Ring, Klip #T5304-75
9	532 12 12-32	Cap, Spindle
13	532 12 17-49	Washer 25/32 x 1-1/4 x 16 Ga.
14	810 04 06-00	Washer, Lock Hvy Hlcl Spr 3/8
15	873 54 06-00	Nut, Crown Lock 3/8-24 unf
16	532 40 82-19	Shaft Steering
19	532 19 47-29	Plate Steering
21	532 18 67-37	Adapter, Wheel Steering
22	532 42 05-37	Steering Support
26	532 43 97-43	Insert, Wheel Steering
28	817 00 06-12	Screw 3/8-16 x 3/4
35	532 19 47-32	Gear, Sector Plate
45	819 18 38-12	Washer 9/16 ID x 2-3/8 OD 12 Ga.
51	873 94 08-00	Nut Hex Jam Toplock 1/2-20 unf
53	532 18 89-67	Washer Hardened .793x1.637x.060
57	532 40 74-65	Bracket Upstop
58	532 19 47-47	Bolt Shoulder Sector Pivot CFM
59	532 19 47-48	Washer Thrust Sector Steering
60	873 97 10-00	Nut Flange Lock 5/8-11
61	532 19 47-40	Draglink, LH
62	532 19 47-41	Draglink, RH
63	817 00 05-12	Screw 5/16-18 x 3/4
64	532 19 98-49	Retainer Clip Spring Steering
66	871 02 07-48	Bolt Hex Fghd 7/16-14 x 3 Serr
67	532 19 47-37	Bushing PM Front Axle
68	873 90 07-00	Nut Lock Flange 7/16-14 Gr. 5
69	532 19 91-62	Washer 1.5 x .505 x .118
70	532 19 61-97	Bracket Deck Susp. Front

**NOTE:** All component dimensions given in U.S. inches  
1 inch = 25.4 mm

TRACTOR - - MODEL NUMBER YTH21K46 (96045002901), PRODUCT NO. 960 45 00-29  
MOWER DECK

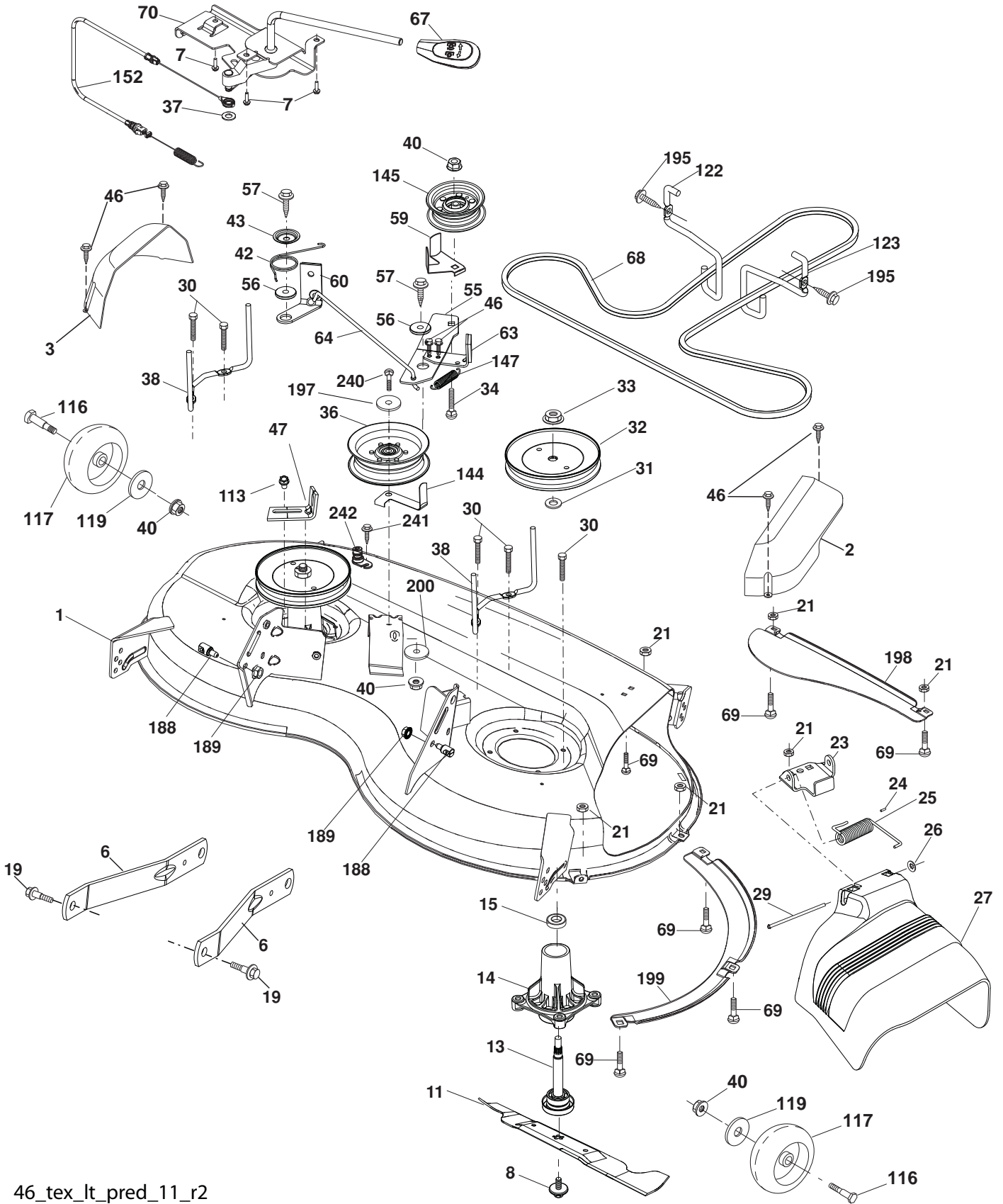

46\_tex\_lt\_pred\_11\_r2

**TRACTOR - - MODEL NUMBER YTH21K46 (96045002901), PRODUCT NO. 960 45 00-29  
MOWER DECK**

<b>KEY PART NO. NO.</b>	<b>DESCRIPTION</b>	<b>KEY PART NO. NO.</b>	<b>DESCRIPTION</b>		
1	532 44 23-82	Mower Housing	63	532 19 94-77	Arm Brake Mower
2	532 40 55-06	Cover Mandrel RH	64	532 40 51-38	Linkage Brake
3	532 40 55-07	Cover Mandrel LH	67	532 40 30-12	Handle, Clutch Cable
6	532 19 51-86	Arm Suspension	68	532 40 51-43	V-Belt
7	532 41 63-58	Screw # 10 x 0.750	69	872 14 05-05	Bolt
8	532 19 30-03	Bolt/Washer asm 7/16-20 unf	70	532 19 99-72	Clutch Asm. Cable
11	532 40 53-80	Blade Mower Hi Lift	113	817 00 05-10	Screw 5/16-18
13	532 19 28-72	Shaft Assembly, Mandrel	116	532 19 34-06	Bolt, Shoulder
14	532 18 72-81	Housing, Mandrel	117	532 17 48-73	Wheel, Gauge
15	532 11 04-85	Bearing, Ball, Mandrel	119	819 13 20-12	Washer 13/32 x 1-1/4 x 12 Ga.
19	532 19 65-39	Bolt, Shoulder	122	532 19 72-58	Keeper Belt Eng. LH
21	873 68 05-00	Nut	123	532 19 72-59	Keeper Belt Eng. RH
23	532 19 25-57	Bracket, Deflector	144	532 19 92-04	Keeper Belt
24	532 10 53-04	Cap, Sleeve	145	532 19 31-97	Pulley Idler
25	532 19 70-26	Spring, Torsion, Deflector	147	532 40 18-72	Spring Return
26	532 11 04-52	Nut, Push	152	532 43 51-10	Cable Clutch Manual w/Spr.
27	532 40 53-57	Shield, Deflector	188	532 19 51-61	Stud Fastener
29	532 13 14-91	Rod, Hinge	189	873 90 05-00	Nut Lock Hex Flange
30	532 17 39-84	Screw Thdrol Rolling Wsh Hd	195	817 00 06-12	Screw 3/8-16 x 3/4
31	532 18 76-90	Washer, Spacer	197	819 13 13-12	Washer 13/32 x 13/16 x 12 Ga.
32	532 19 74-73	Pulley, Mandrel	198	532 40 31-49	Baffle Center Front
33	532 40 02-34	Nut, Toplock, Flanged	199	532 40 31-50	Baffle Front RH
34	872 11 06-12	Bolt Carr Sh. 3/8-16 x 1-1/2 Gr. 5	200	532 41 35-24	Washer 13/32 x 1 x 1/2 11 Ga.
36	532 19 73-79	Pulley, Idler, Flat	240	874 52 06-36	Bolt 3/8-16 unc x 2-1/4 Gr. 5
37	819 13 13-16	Washer 13/32 x 13/16 x 16 Ga.	241	532 15 29-27	Screw
38	532 43 25-20	Keeper Belt Mandrel	242	532 41 55-98	Washout Port
40	873 90 06-00	Nut, Lock Flg. 3/8-16 unc	--	532 41 64-05	Quick Connect Coupling
42	532 19 84-10	Spring Torsion Brake	--	532 19 28-70	Mandrel Assembly (Includes hous- ing, shaft assembly, and bearing only - pulley/nut/washer and blade bolt/washers not included)
43	532 19 72-56	Spring Torsion Retainer	--	532 43 18-23	Replacement Mower, Complete
46	532 13 77-29	Screw			
47	532 19 72-50	Bracket Clutch Cable			
55	532 19 72-49	Arm, Idler			
56	532 19 90-92	Spacer, Retainer			
57	817 00 06-16	Screw Hexwsh Thd 3/8-16 x 1			
59	532 14 10-43	Guard, Tuv Idler (94)			
60	532 19 94-71	Arm Brake Mower LH			

**NOTE:** All component dimensions given in U.S. inches  
1 inch = 25.4 mm

**TRACTOR - - MODEL NUMBER YTH21K46 (96045002901), PRODUCT NO. 960 45 00-29  
MOWER LIFT**

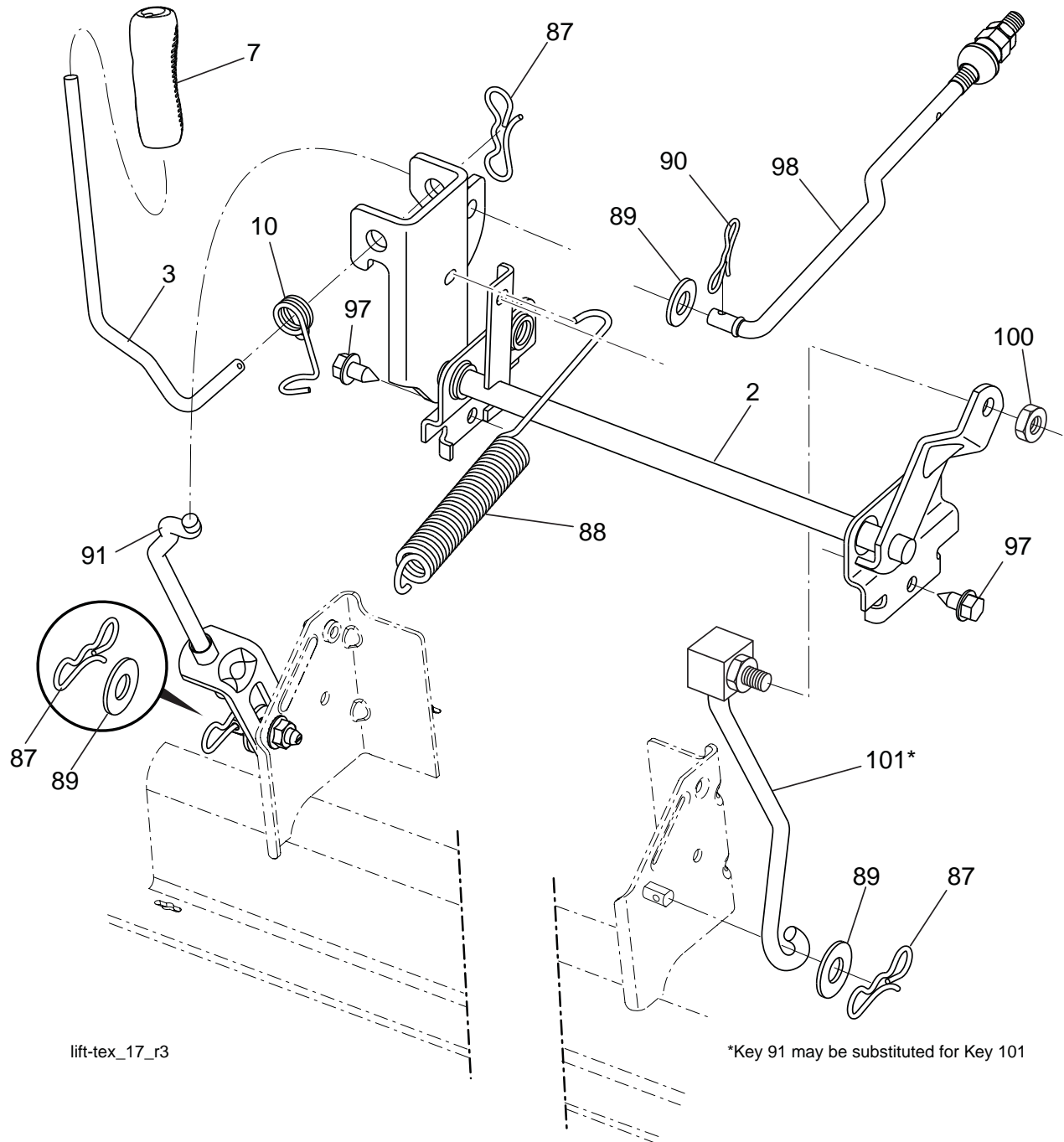

lift-tex\_17\_r3

\*Key 91 may be substituted for Key 101

KEY NO.	PART NO.	DESCRIPTION
2	532 42 20-27	Shaft Asm., Lift
3	532 19 52-31	Lever Asm., Lift RH
7	532 41 15-55	Grip, Lever
10	532 19 63-14	Spring Torsion
87	532 19 42-09	Pin Cotter 7/16 Bow Tie Lock
88	532 41 07-10	Spring Lift Assist
89	819 19 19-12	Washer Clear Zinc
90	532 19 42-08	Pin Cotter 5/16 Bow Tie Lock
91	532 19 51-81	Link Lift Susp Mower Rear

KEY NO.	PART NO.	DESCRIPTION
97	817 00 06-12	Screw 3/8-16 x .75 Smgml Tap/R.Z
98	532 19 52-70	Link Lift Susp. Front Mower
100	873 93 06-00	Nut Center Lock 3/8-16 unc
101	532 40 70-03	Link Asm Lift Fixed

**NOTE:** All component dimensions given in U.S. inches  
1 inch = 25.4 mm



**TRACTOR - - MODEL NUMBER YTH21K46 (96045002901), PRODUCT NO. 960 45 00-29  
SEAT ASSEMBLY**

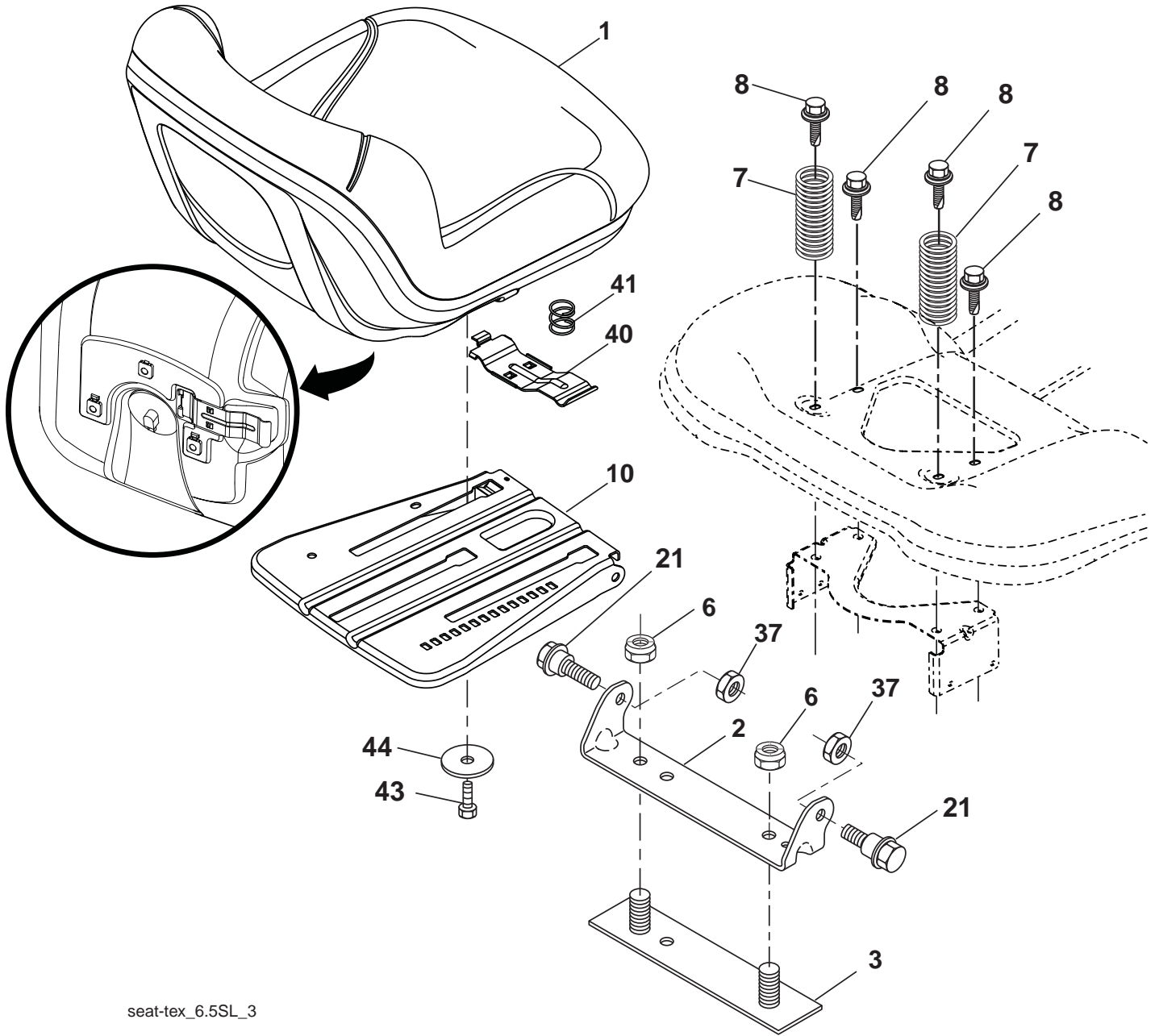

seat-tex\_6.5SL\_3

KEY NO.	PART NO.	DESCRIPTION
1	532 43 98-22	Seat
2	532 18 01-66	Bracket Pivot Fender
3	532 14 06-75	Strap, Asm Fender
6	873 80 06-00	Nut, Lock w/Ins. 3/8-16 unc
7	532 12 41-81	Spring, Seat Cprsn
8	532 17 18-77	Bolt 5/16-18 unc x 3/4 w/Sems
10	532 19 69-77	Pan, Seat
21	532 17 18-52	Bolt, Shoulder 5/16-18

KEY NO.	PART NO.	DESCRIPTION
37	873 80 05-00	Nut, Lock 5/16-18 unc
40	532 19 76-61	Handle Slide Seat
41	532 19 82-00	Spring Latch Seat
43	874 76 06-12	Bolt Fin Hex 3/8-16 unc x 3/4
44	819 13 38-12	Washer 13/32 x 2-3/8 x 12 Ga.

**NOTE:** All component dimensions given in U.S. inches  
1 inch = 25.4 mm

**TRACTOR - - MODEL NUMBER YTH21K46 (96045002901), PRODUCT NO. 960 45 00-29  
DECALS**

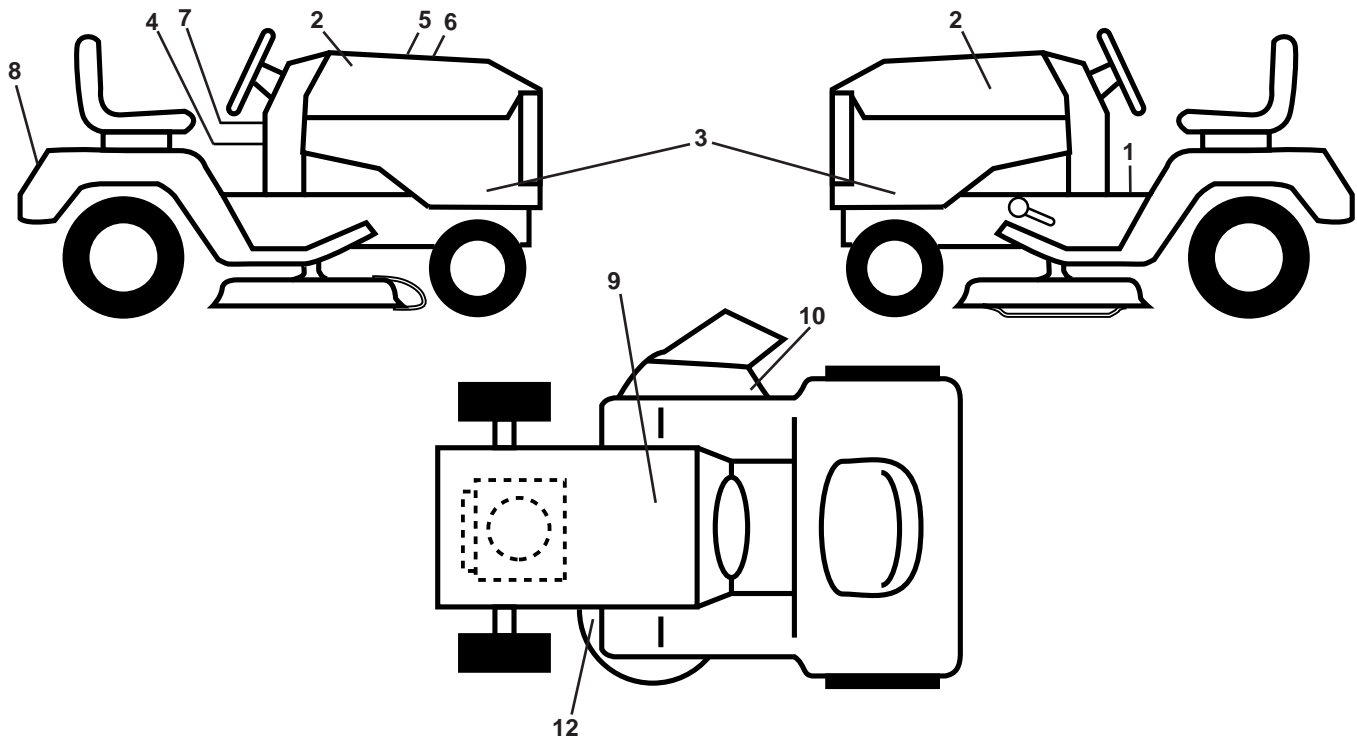

KEY NO.	PART NO.	DESCRIPTION	KEY NO.	PART NO.	DESCRIPTION
1	532 41 91-38	Decal, Fender Warning	9	532 14 50-05	Decal, Battery Dnge/Poi
2	532 42 91-96	Decal, Hood	10	532 17 05-63	Decal, Mower Warning
3	532 43 95-66	Decal, Hood Panel SD	12	532 16 03-96	Decal, Mower V-Belt Schematic
4	532 42 41-02	Decal, Bypass	--	532 16 69-60	Decal, Bypass
5	532 42 38-29	Decal, Customer Respons.	--	532 43 96-81	Pad, Footrest, LH
6	532 43 96-69	Decal, Replacement	--	532 43 96-82	Pad, Footrest, RH
7	532 43 63-90	Decal, Label Emiss.	--	532 44 41-83	Manual, Owner's (English)
8	532 19 15-54	Decal, Fender	--	532 44 41-84	Manual, Owner's (Spanish)

**WHEELS AND TIRES**

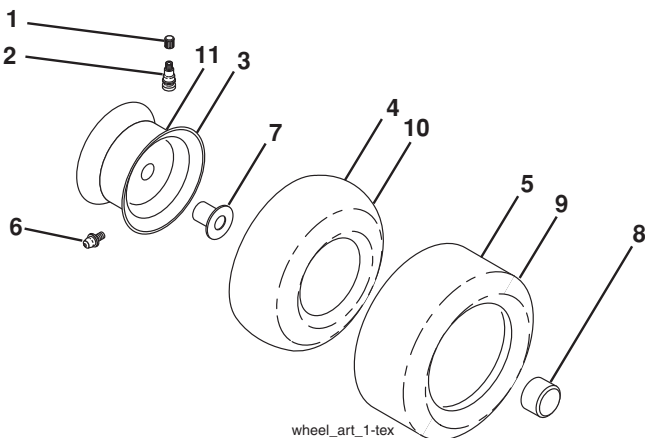

KEY NO.	PART NO.	DESCRIPTION
1	532 05 91-92	Cap Valve Tire
2	532 06 51-39	Stem Valve
3	532 13 83-36	Rim Front
4	532 05 99-04	Tube Front (Service Item Only)
5	532 10 62-22	Tire Front 15 x 6.0-6
6	532 12 49-57	Fitting Grease (Front Wheel Only)
7	532 12 49-59	Bearing Flange (Front Wheel Only)
8	532 17 50-39	Cap Axle Blk 1 50 x 1 00
9	532 13 84-68	Tire R 20 x 8-8 Turf Saver LT
10	532 12 49-26	Tube Rear (Service Item Only)
11	532 13 83-37	Rim Asm 8" Rear
--	532 14 43-34	Sealant, Tire (10 oz. Tube)

**NOTE:** All component dimensions given in U.S. inches  
1 inch = 25.4 mm

# SUGGESTED GUIDE FOR SIGHTING SLOPES FOR SAFE OPERATION

