



SPARE PARTS LIST

ROBOTIC LAWN MOWERS

260 ACX, 2011-02

H Accessories
Zubehöre
Accessoires
Accesorios
Tillbehör

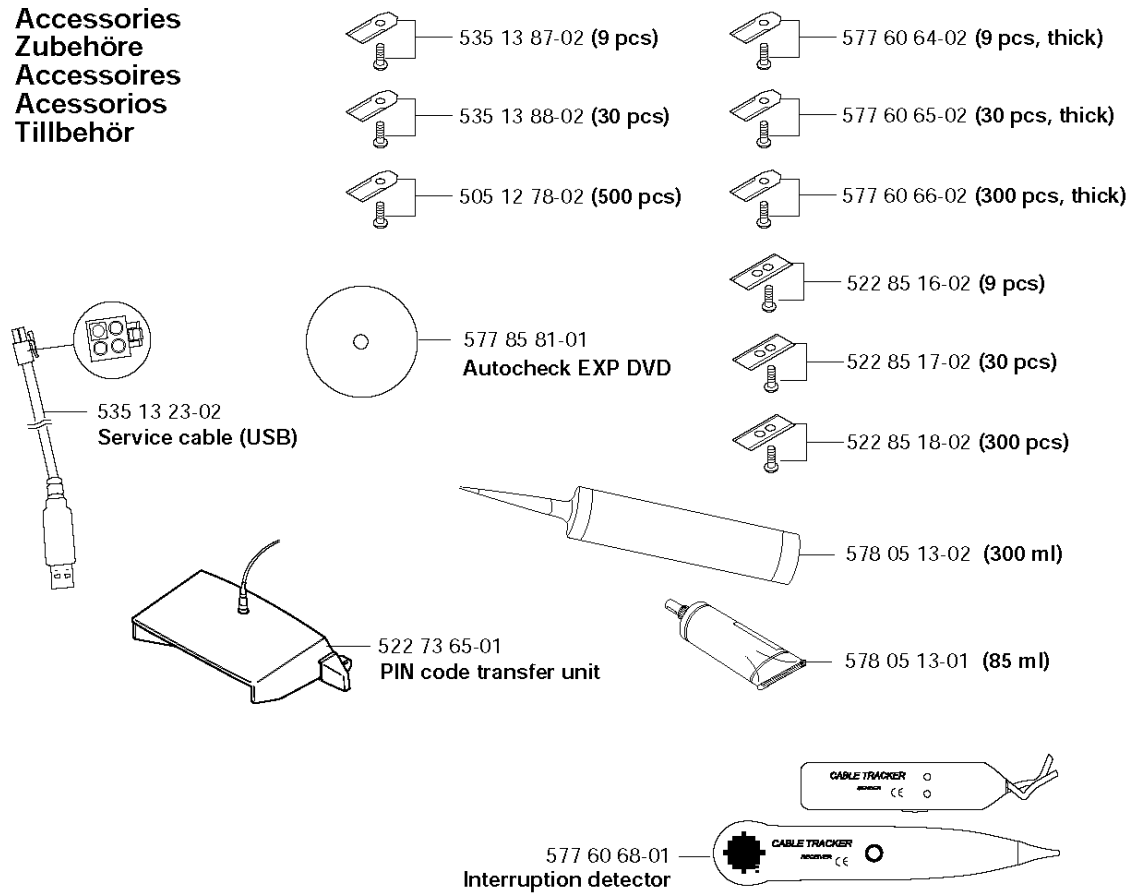

ACCESSORIES

260 ACX, 2011-02

Part No	Description	Remark	QTY KIT
505 12 78-02	BLADE		1
522 42 58-01	BOOSTER		1
522 73 65-01	ADAPTER		1
522 85 16-02	BLADE		1
522 85 17-02	BLADE		1
522 85 18-02	BLADE		1
522 91 66-01	BAG		1
535 13 23-02	WIRING		1
535 13 87-02	BLADE(9PCS)		1
535 13 88-02	BLADE 30PCS		1
575 23 17-02	WHEEL KIT		1
577 60 64-02	BLADE		1
577 60 65-02	BLADE		1
577 60 66-02	BLADE		1
577 60 68-01	TEST EQUIPMENT		1
577 85 81-01	DVD		1
578 05 13-01	GREASE TUBE		1
578 05 13-02	GREASE TUBE		1

D

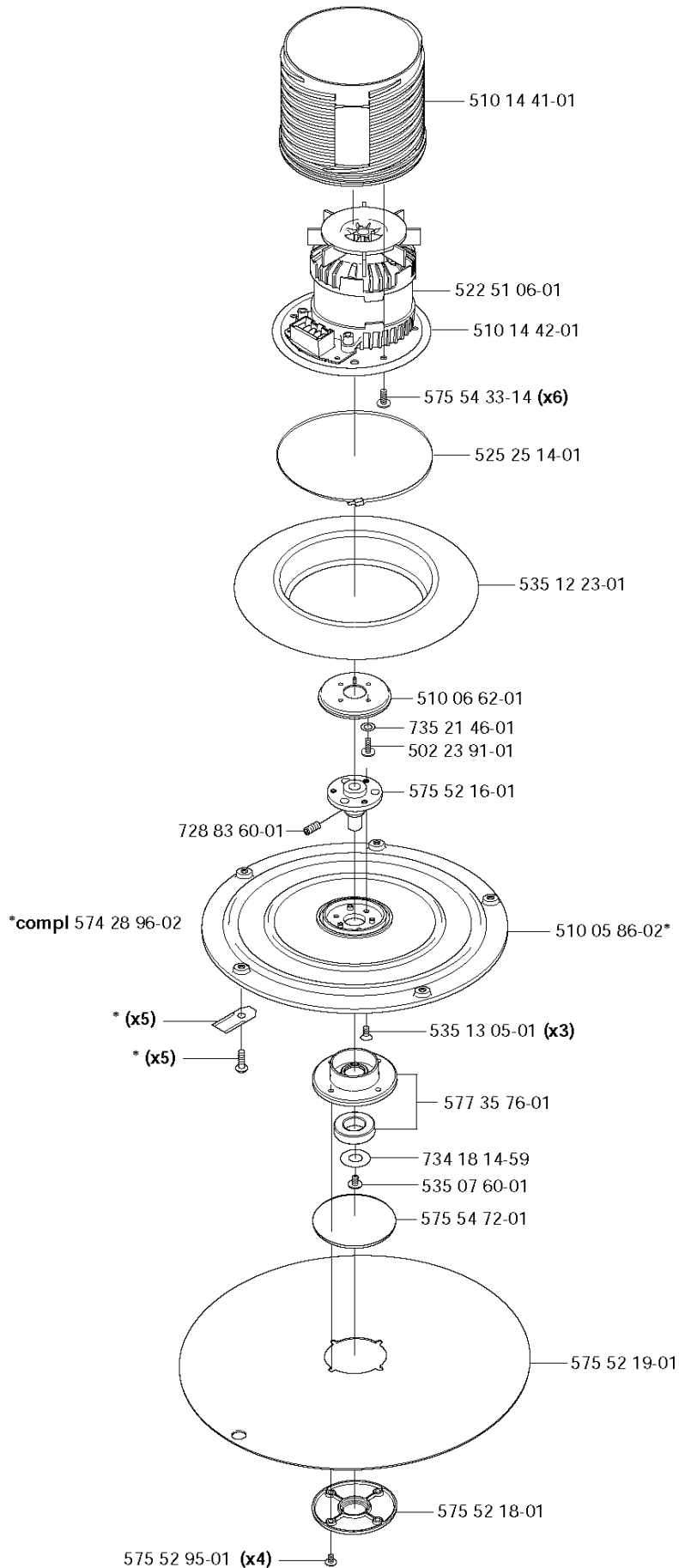

BLADE MOTOR & CUTTING EQUIPMENT

260 ACX, 2011-02

Part No	Description	Remark	QTY KIT
502 23 91-01	SCREW		1
510 05 86-02	DISC		1
510 06 62-01	COLLAR		1
510 14 41-01	MOTOR BOWL		1
510 14 42-01	DISC		1
522 51 06-01	CUTTING ENGINE		1
525 25 14-01	TIE WRAP		1
535 07 60-01	SCREW		1
535 12 23-01	RUBBER GAITERS		1
535 13 05-01	SCREW		3
574 28 96-02	KIT		1
575 52 16-01	HUB		1
575 52 18-01	BEARING COVER		1
575 52 19-01	SKID PLATE		1
575 52 95-01	SCREW ITPANTT		4
575 54 33-14	SCREW		6
575 54 72-01	O-RING		1
577 35 76-01	BEARING KIT		5
728 83 60-01	SCREW IHSETM		5
734 18 14-59	WASHER		1
735 21 46-01	LOCK WASHER		1

E compl 574 90 20-03
compl 574 90 20-05 (CH)

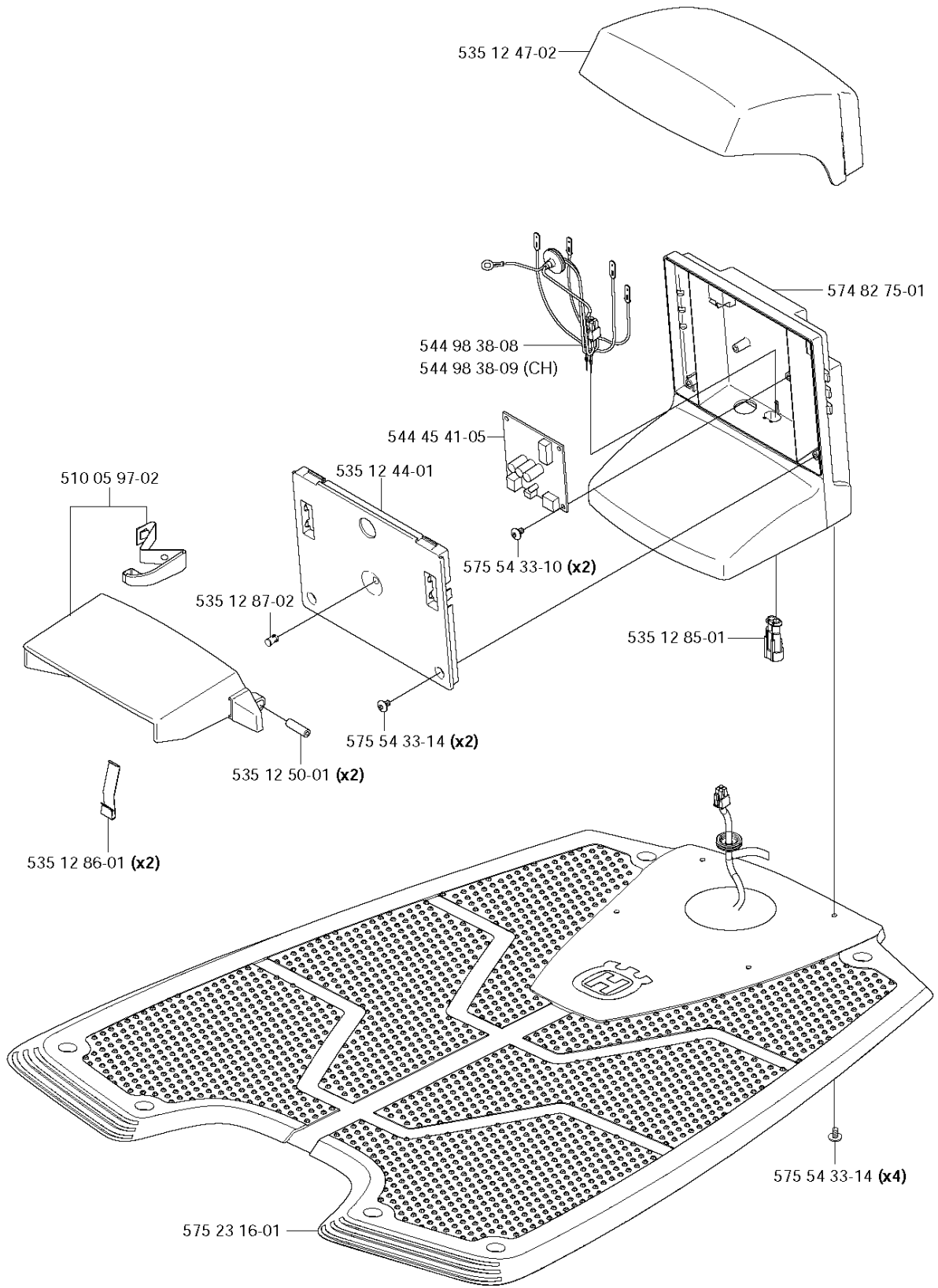

CHARGING STATION

260 ACX, 2011-02

Part No	Description	Remark	QTY KIT
510 05 97-02	KIT		1
535 12 44-01	HUB CAP		1
535 12 47-02	COVER		1
535 12 50-01	PIN		2
535 12 85-01	CONTACT HOUSING		1
535 12 86-01	SPRING PLATE		2
535 12 87-02	DIODE LENS		1
544 45 41-05	CIRCUIT BOARD ASSY		1
544 98 38-08	WIRING ASSY		1
544 98 38-09	WIRING ASSY		1
574 82 75-01	BODY		1
574 90 20-03	CHARGING STATION		1
574 90 20-05	CHARGING STATION		1
575 23 16-01	CHARGING PLATE		1
575 54 33-10	SCREW		2
575 54 33-14	SCREW		2
575 54 33-14	SCREW		4

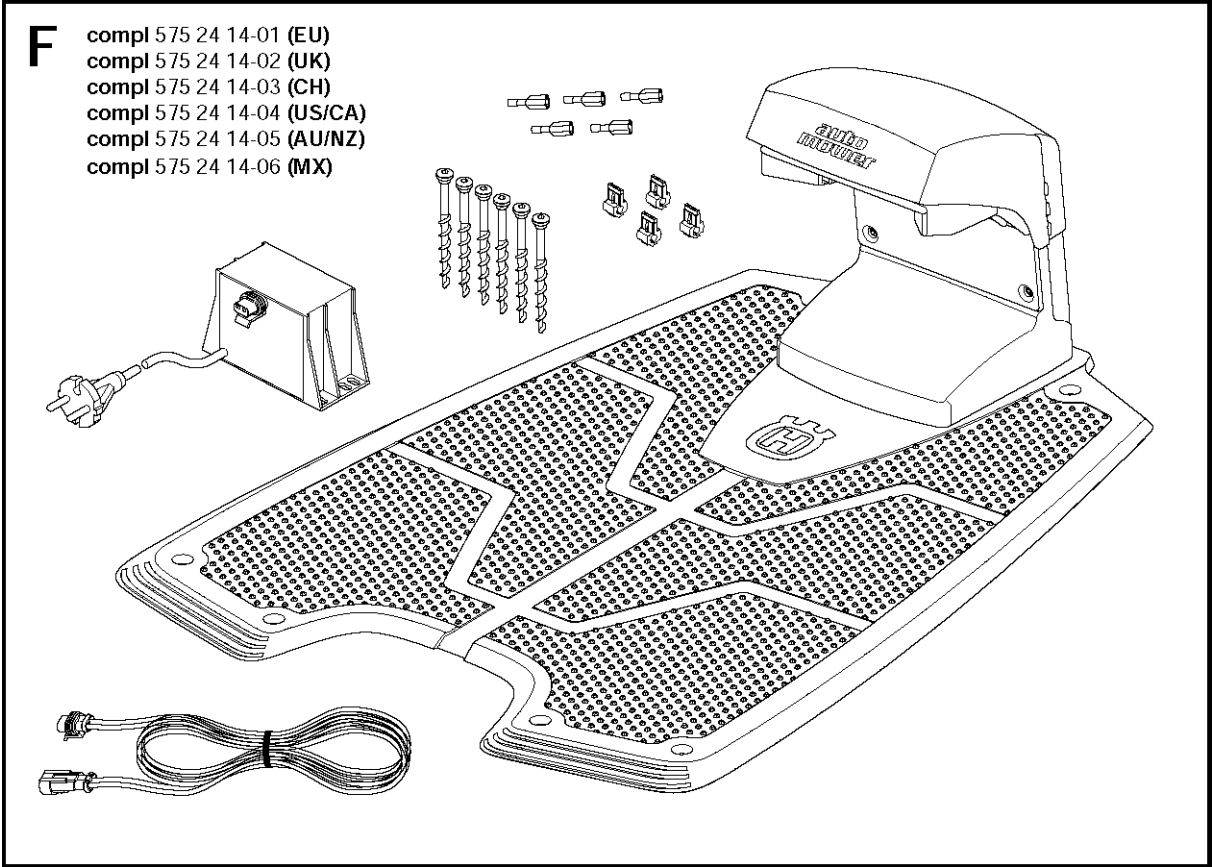

CHARGING STATION

260 ACX, 2011-02

Part No	Description	Remark	QTY KIT
575 24 14-01	CHARGING STATION		1
575 24 14-02	CHARGING STATION		1
575 24 14-03	CHARGING STATION		1
575 24 14-04	CHARGING STATION		1
575 24 14-05	CHARGING STATION		1
575 24 14-06	CHARGING STATION		1

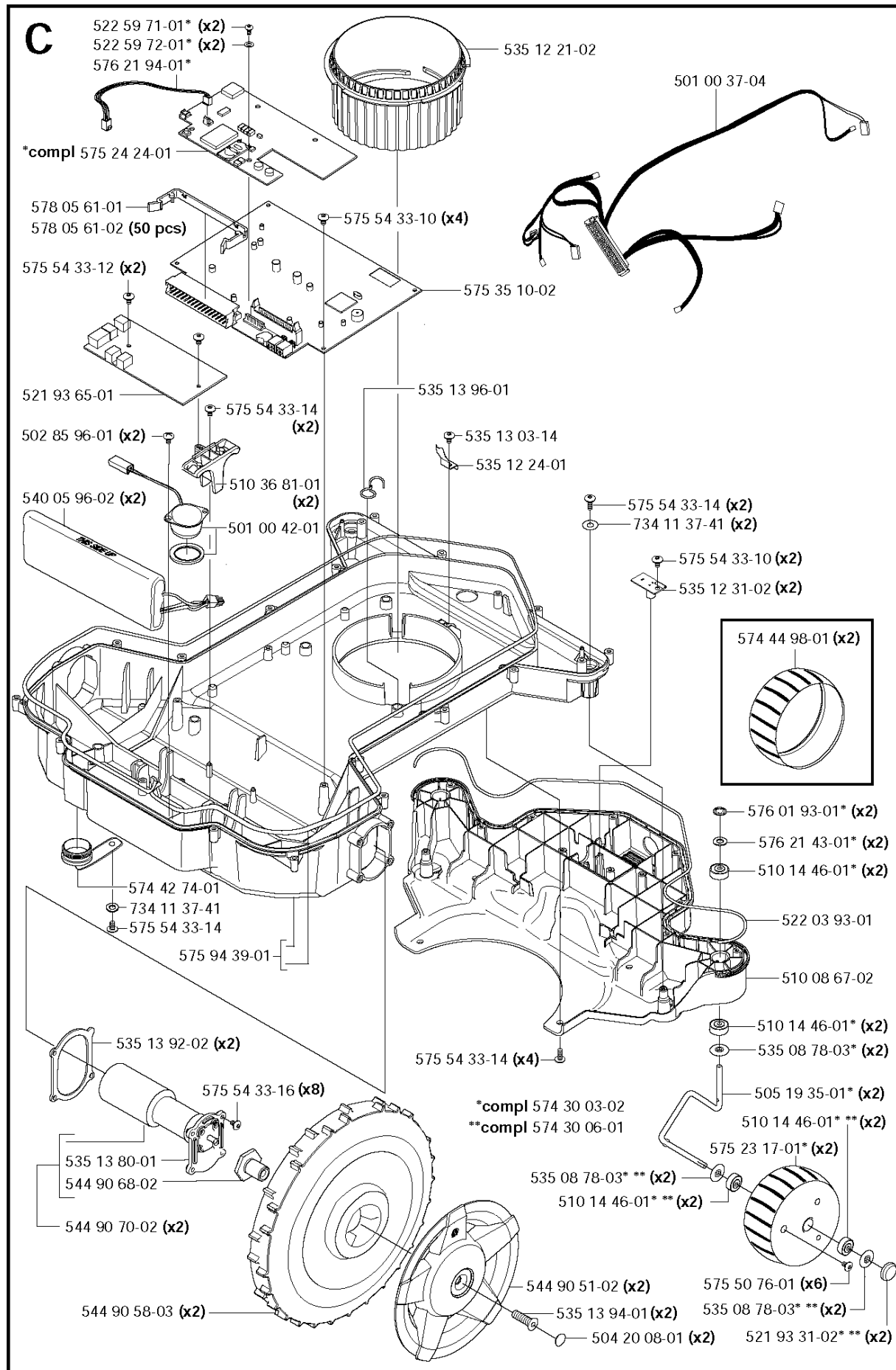

CHASSIS LOWER

260 ACX, 2011-02

Part No	Description	Remark	QTY KIT
501 00 37-04	MAIN WIRING		2
501 00 42-01	LOUD SPEAKER		1
502 85 96-01	SCREW		2
504 20 08-01	COVER WASHER		2
505 19 35-01	SPINDLE		2
510 08 67-02	BRACKET		2
510 14 46-01	BALL BEARING		2
510 14 46-01	BALL BEARING		2
510 14 46-01	BALL BEARING		2
510 14 46-01	BALL BEARING		2
510 36 81-01	BRACKET		2
521 93 31-02	COVER WASHER		2
521 93 65-01	PRINTED CIRCUIT ASSY		1
522 03 93-01	SEALING RING		1
522 59 71-01	SCREW		1
522 59 72-01	WASHER		1
535 08 78-03	WASHER		2
535 08 78-03	WASHER		2
535 08 78-03	WASHER		2
535 12 21-02	NUT		1
535 12 24-01	LOCKING SPRING		1
535 12 31-02	SENSOR CARD		2
535 13 03-14	SCREW ITXPANT		1
535 13 80-01	MOTOR GABLE		1
535 13 92-02	GASKET		2
535 13 94-01	SCREW IHCSFM		2
535 13 96-01	CABLE HOLDER		1
540 05 96-02	BATTERY		2
544 90 51-02	HUB CAP		2
544 90 58-03	REAR WHEEL		2
544 90 68-02	HUB		1
544 90 70-02	DRIVE MOTOR		2
574 30 03-02	KIT		1
574 30 06-01	KIT		1
574 42 74-01	PLUG		1
574 44 98-01	WHEEL		2
575 23 17-01	WHEEL ASSY		2
575 24 24-01	GPS MODULE		1
575 35 10-02	PRINTED CIRCUIT ASSY		1
575 50 76-01	SCREW ITXPANT		6
575 54 33-10	SCREW		2
575 54 33-10	SCREW		4
575 54 33-12	SCREW		2
575 54 33-14	SCREW		2
575 54 33-14	SCREW		2
575 54 33-14	SCREW		4
575 54 33-14	SCREW		1
575 54 33-16	SCREW		8
575 94 39-01	CHASSIS		1
576 01 93-01	LOCK WASHER		2
576 21 43-01	WASHER		2
576 21 94-01	LOOM		1
578 05 61-01	CLIP		1
578 05 61-02	CLIP		1
734 11 37-41	WASHER		2
734 11 37-41	WASHER		1

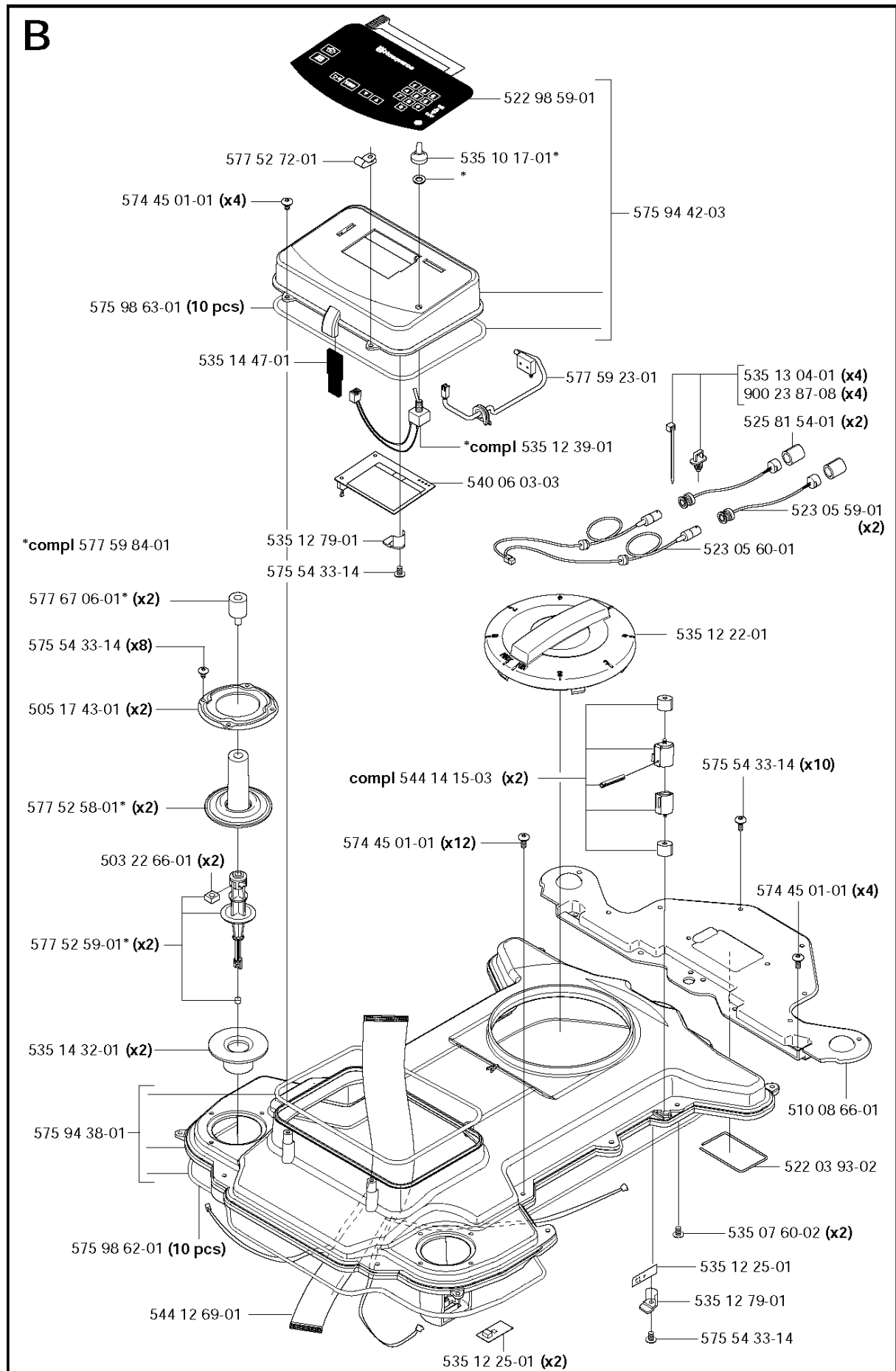

CHASSIS UPPER

260 ACX, 2011-02

Ref	Part No	Description	Remark	QTY KIT
522 98 59-01	522 98 59-01	KEYBOARD		1
540 06 03-03	540 06 03-03	DISPLAY		1
535 12 79-01	535 12 79-01	BRACKET		1
575 54 33-14	575 54 33-14	SCREW		1
523 05 59-01	523 05 59-01	WIRING ASSY		1
577 67 06-01	577 67 06-01	RUBBER DAMPER		2
577 52 59-01	577 52 59-01	COLUMN		2
535 14 32-01	535 14 32-01	DEFLECTION LIMITER		2
575 54 33-14	575 54 33-14	SCREW		8
505 17 43-01	505 17 43-01	RING FASTENER		2
577 52 58-01	577 52 58-01	RUBBER GAITERS		2
535 13 04-01	535 13 04-01	ANCHOR		4
900 23 87-08	900 23 87-08	TIE WRAP		4
523 05 60-01	523 05 60-01	WIRING ASSY		2
577 59 23-01	577 59 23-01	SWITCH KIT		1
574 45 01-01	574 45 01-01	SCREW ITXPANT		4
575 94 42-03	575 94 42-03	DISPLAY COVER		1
535 10 17-01	535 10 17-01	HUB CAP		1
535 12 39-01	535 12 39-01	MAIN SWITCH		1
535 14 47-01	535 14 47-01	FILTER		1
575 98 63-01	575 98 63-02	SEALING STRIP		1
577 52 72-01	577 52 72-01	CABLE CLAMP		1
525 81 54-01	525 81 54-01	TUBE		2
544 12 69-01	544 12 69-01	WIRING		1
535 12 25-01	535 12 25-01	SENSOR CARD		2
575 54 33-14	575 54 33-14	SCREW		1
535 12 79-01	535 12 79-01	BRACKET		1
535 12 25-01	535 12 25-01	SENSOR CARD		1
575 94 38-01	575 94 38-01	CHASSIS		1
575 98 62-01	575 98 62-02	SEALING STRIP		1
574 45 01-01	574 45 01-01	SCREW ITXPANT		1
503 22 66-01	503 22 66-01	SQUARE NUT		12
535 07 60-02	535 07 60-02	SCREW		2
535 12 22-01	535 12 22-01	STEERING WHEEL		1
575 54 33-14	575 54 33-14	SCREW		10
574 45 01-01	574 45 01-01	SCREW ITXPANT		4
510 08 66-01	510 08 66-01	BRACKET		1
522 03 93-02	522 03 93-02	SEALING RING		1
577 59 84-01	577 59 84-01	COLUMN		1
544 14 15-03	544 14 15-03	SENSOR		2

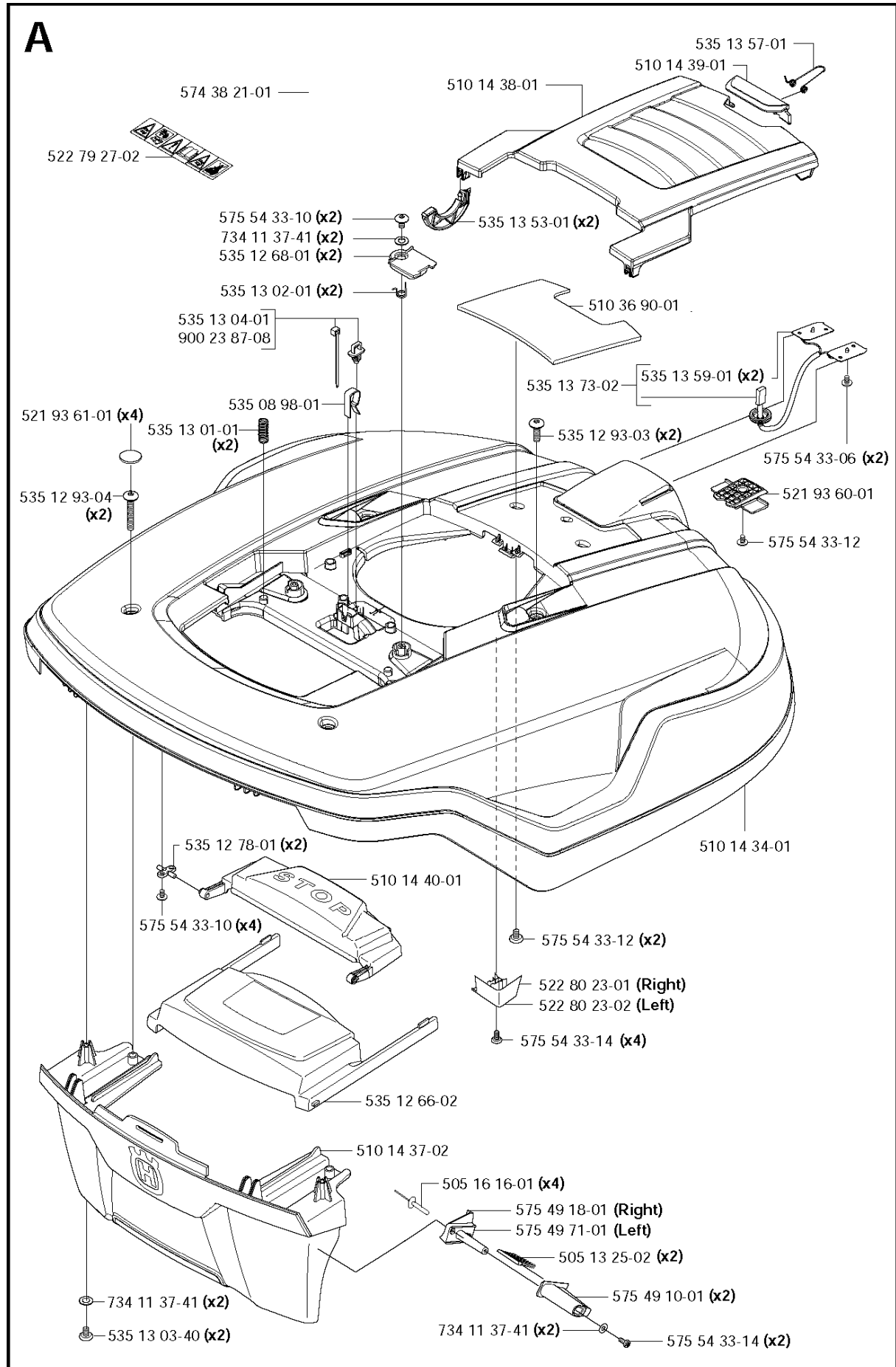

COVER

260 ACX, 2011-02

Part No	Description	Remark	QTY KIT
505 13 25-02	BRUSH		1
505 16 16-01	RIVET		4
510 14 34-01	MAIN BODY		1
510 14 37-02	MAIN BODY		1
510 14 38-01	LID		1
510 14 39-01	LATCH		1
510 14 40-01	BUTTON		1
510 36 90-01	PLATE		1
521 93 60-01	SPACER		1
521 93 61-01	COVER WASHER		4
522 79 27-02	LABEL WARNING		1
522 80 23-01	BRACKET		2
522 80 23-02	BRACKET		1
535 08 98-01	CLIPS		1
535 12 66-02	COVER		1
535 12 68-01	LOCK CLAMP		2
535 12 78-01	SHAFT		2
535 12 93-03	SCREW IH PANM		2
535 12 93-04	SCREW IH PANM		2
535 13 01-01	SPRING		2
535 13 02-01	TORSION SPRING		2
535 13 03-40	SCREW ITXPANT		2
535 13 04-01	ANCHOR		1
535 13 53-01	PIVOT		2
535 13 57-01	TORSION SPRING		1
535 13 59-01	CHARGING PLATE		2
535 13 73-02	WIRING		1
574 38 21-01	DECAL		1
575 49 10-01	BRUSH HOLDER		1
575 49 18-01	BRACKET		1
575 49 71-01	BRACKET		1
575 54 33-06	SCREW		1
575 54 33-10	SCREW		2
575 54 33-10	SCREW		1
575 54 33-12	SCREW		2
575 54 33-12	SCREW		1
575 54 33-14	SCREW		1
575 54 33-14	SCREW		4
734 11 37-41	WASHER		2
734 11 37-41	WASHER		1
734 11 37-41	WASHER		2
900 23 87-08	TIE WRAP		1

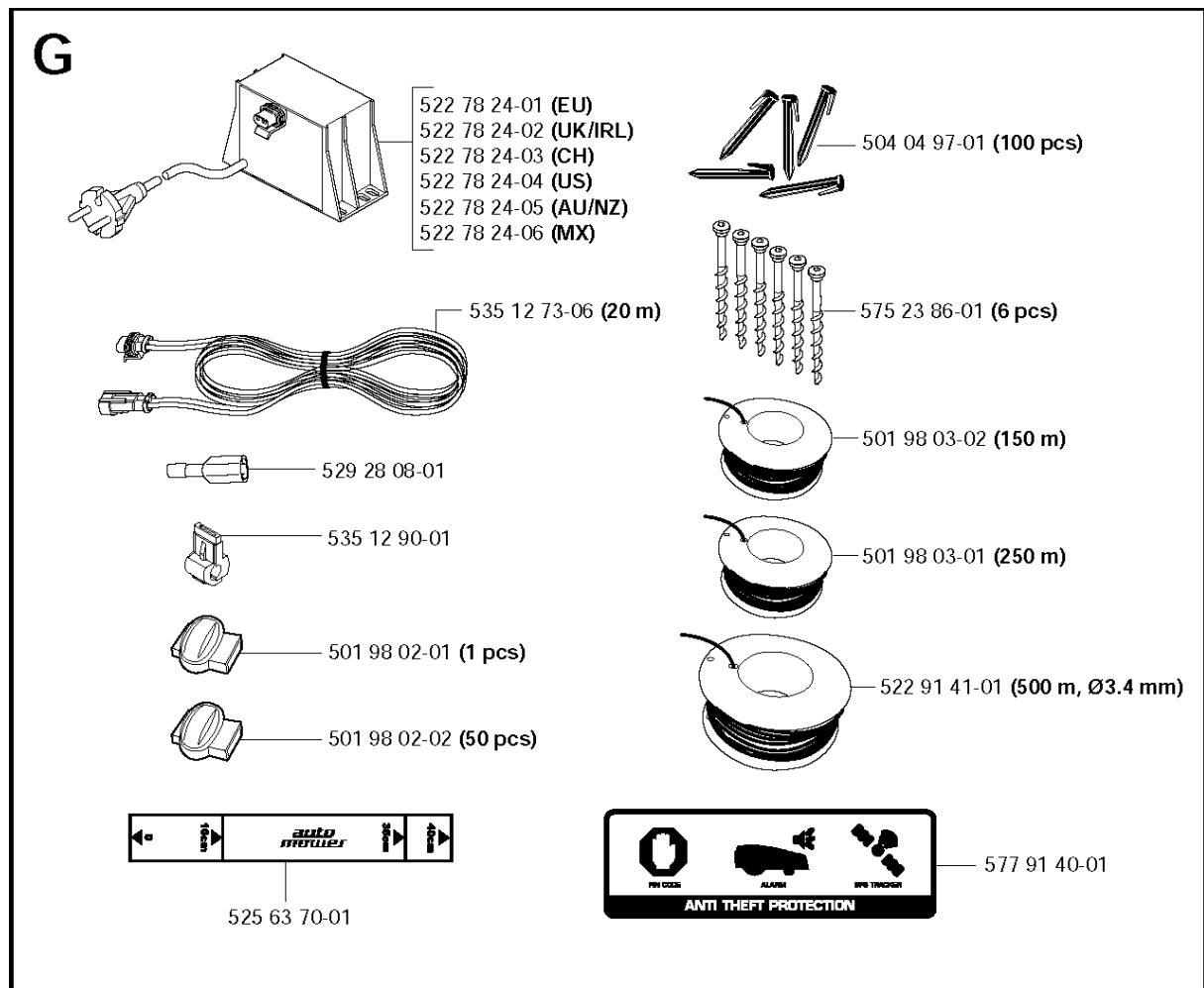

INSTALLATION ACCESSORIES

260 ACX, 2011-02

Part No	Description	Remark	QTY KIT
501 98 02-01	COUPLER		1
501 98 02-02	COUPLER		1
501 98 03-01	WIRE		1
501 98 03-02	WIRE		1
504 04 97-01	STAPLE		1
522 78 24-01	TRANSFORMER		1
522 78 24-02	TRANSFORMER		1
522 78 24-03	TRANSFORMER		1
522 78 24-04	TRANSFORMER		1
522 78 24-05	TRANSFORMER		1
522 78 24-06	TRANSFORMER		1
522 91 41-01	WIRE		1
525 63 70-01	MEASURING ROD		1
529 28 08-01	TERMINAL		1
535 12 73-06	CABLE		1
535 12 90-01	COUPLER		1
575 23 86-01	SCREW KIT		1
577 91 40-01	LABEL		1