



SPARE PARTS LIST

ROBOTIC LAWN MOWERS

SOLAR HYBRID , 2011-01

**Accessories
Zubehöre
Accessoires
Accessorios
Tillbehör**

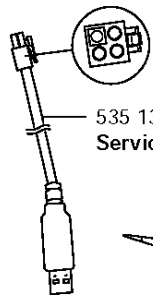

535 13 23-02
Service cable (USB)



535 13 87-02 (9 pcs)



535 13 88-02 (30 pcs)



505 12 78-02 (500 pcs)



577 85 81-01
Autocheck EXP DVD

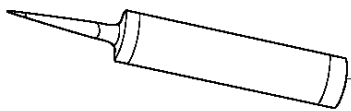

578 05 13-02 (300 ml)

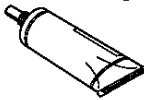

578 05 13-01 (85 ml)

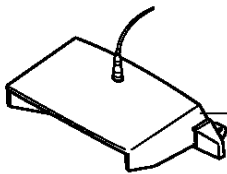

522 73 65-01
PIN code transfer unit



577 60 64-02 (9 pcs, thick)



577 60 65-02 (30 pcs, thick)



577 60 66-02 (300 pcs, thick)



522 85 16-02 (9 pcs)



522 85 17-02 (30 pcs)



522 85 18-02 (300 pcs)

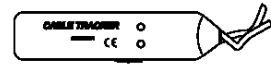

577 60 68-01
Interruption detector

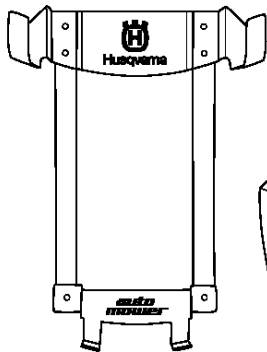
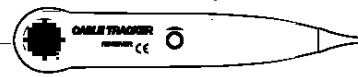

504 82 13-01

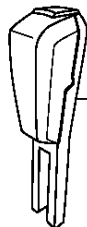

522 42 58-01
Signal booster

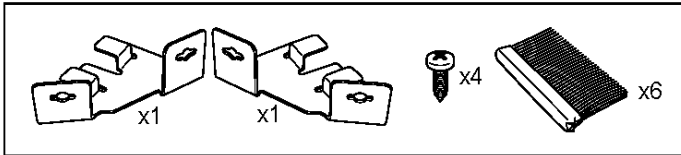

505 13 27-01

505 13 28-01

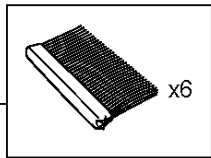

522 91 67-01

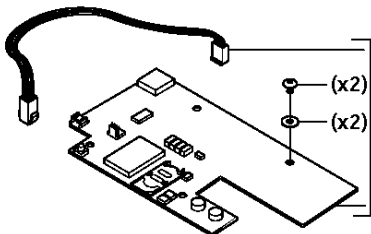

575 24 24-01 GPS module

575 23 17-02
Heavy wheel (400g)

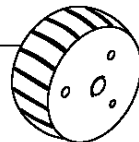

ACCESSORIES

SOLAR HYBRID , 2011-01

Part No	Description	Remark	QTY KIT
504 82 13-01	WALL HANGER		1
505 12 78-02	BLADE		1
505 13 27-01	BRUSH KIT		1
505 13 28-01	BRUSH		1
522 42 58-01	BOOSTER		1
522 73 65-01	ADAPTER		1
522 85 16-02	BLADE		1
522 85 17-02	BLADE		1
522 85 18-02	BLADE		1
522 91 67-01	BAG		1
535 13 23-02	WIRING		1
535 13 87-02	BLADE(9PCS)		1
535 13 88-02	BLADE 30PCS		1
575 23 17-02	WHEEL KIT		1
575 24 24-01	GPS MODULE		1
577 60 64-02	BLADE		1
577 60 65-02	BLADE		1
577 60 66-02	BLADE		1
577 60 68-01	TEST EQUIPMENT		1
577 85 81-01	DVD		1
578 05 13-01	GREASE TUBE		1
578 05 13-02	GREASE TUBE		1

E

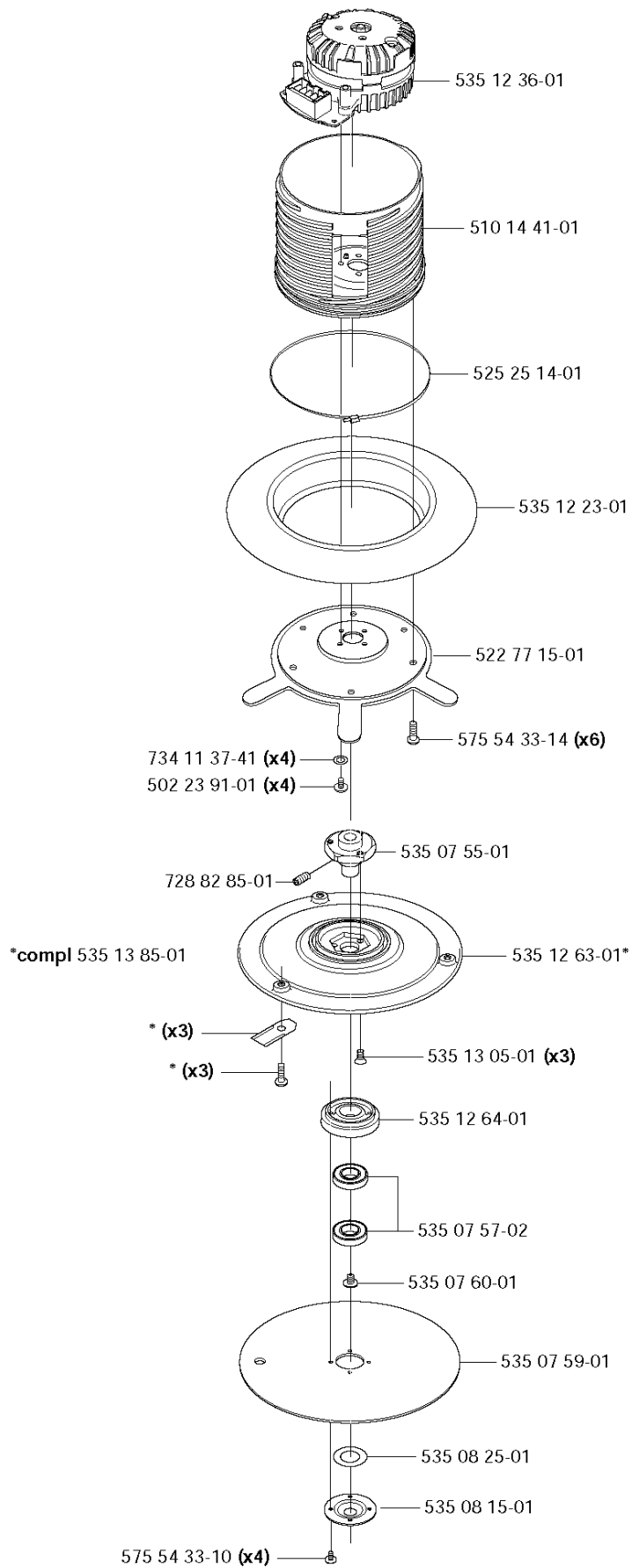

BLADE MOTOR & CUTTING EQUIPMENT

SOLAR HYBRID , 2011-01

Part No	Description	Remark	QTY KIT
502 23 91-01	SCREW		4
510 14 41-01	MOTOR BOWL		1
522 77 15-01	PLATE		1
525 25 14-01	TIE WRAP		1
535 07 55-01	HUB		1
535 07 57-02	BALL BEARING		1
535 07 59-01	SKID PLATE		1
535 07 60-01	SCREW		1
535 08 15-01	COVER WASHER		1
535 08 25-01	GASKET		1
535 12 23-01	RUBBER GAITERS		1
535 12 36-01	CUTTING ENGINE		1
535 12 63-01	KNIFE DISK		1
535 12 64-01	BEARING BOX		1
535 13 05-01	SCREW		3
535 13 85-01	KIT		3
575 54 33-10	SCREW		4
575 54 33-14	SCREW		6
728 82 85-01	SCREW IHSETM		1
734 11 37-41	WASHER		4

F compl 574 90 20-02
compl 574 90 20-05 (CH)

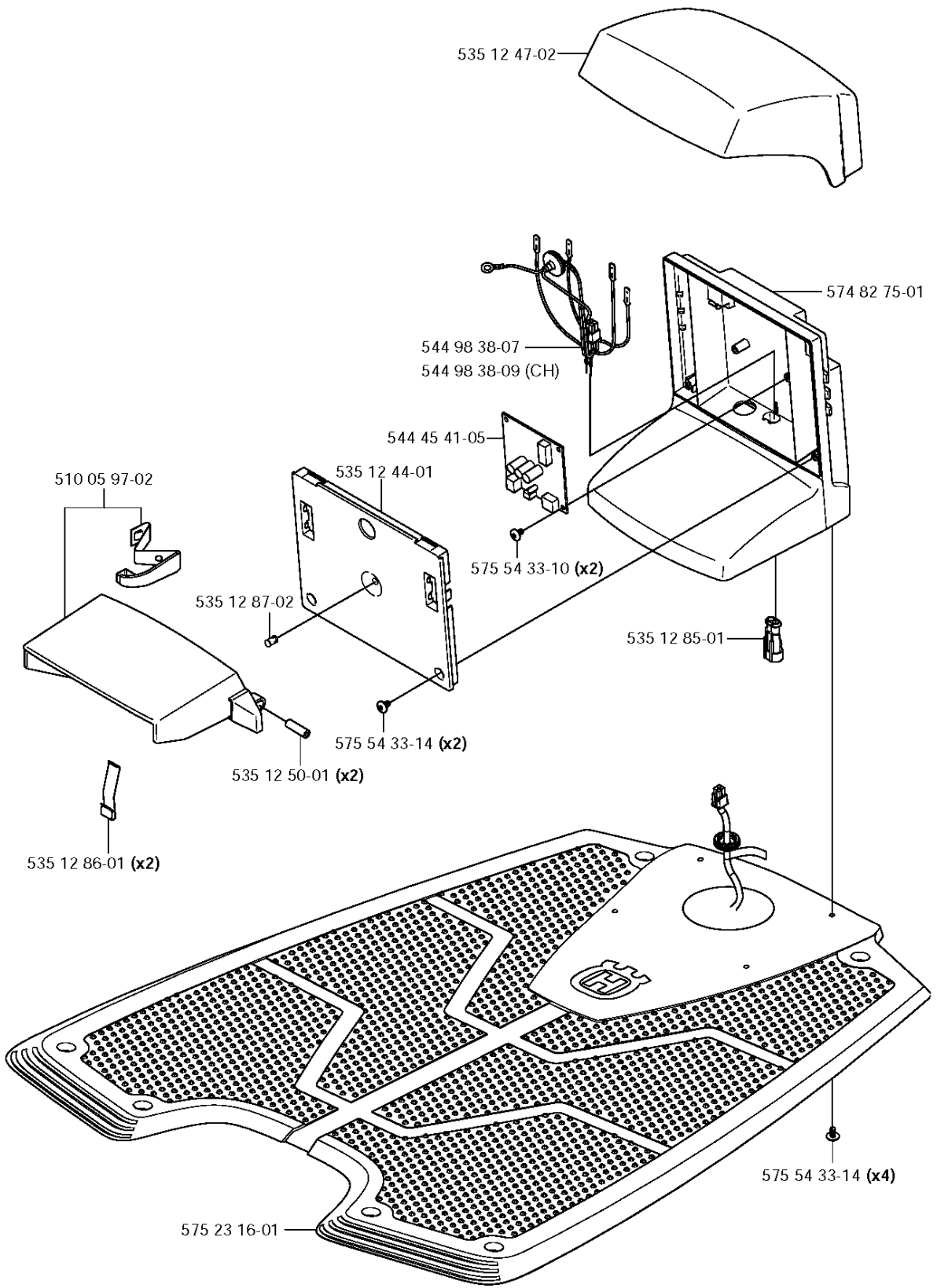

CHARGING STATION

SOLAR HYBRID , 2011-01

Part No	Description	Remark	QTY KIT
510 05 97-02	KIT		1
535 12 44-01	HUB CAP		1
535 12 47-02	COVER		1
535 12 50-01	PIN		2
535 12 85-01	CONTACT HOUSING		1
535 12 86-01	SPRING PLATE		2
535 12 87-02	DIODE LENS		1
544 45 41-05	CIRCUIT BOARD ASSY		1
544 98 38-07	WIRING ASSY		1
544 98 38-09	WIRING ASSY		1
574 82 75-01	BODY		1
574 90 20-02	CHARGING STATION		1
574 90 20-05	CHARGING STATION		1
575 23 16-01	CHARGING PLATE		1
575 54 33-10	SCREW		2
575 54 33-14	SCREW		2
575 54 33-14	SCREW		4

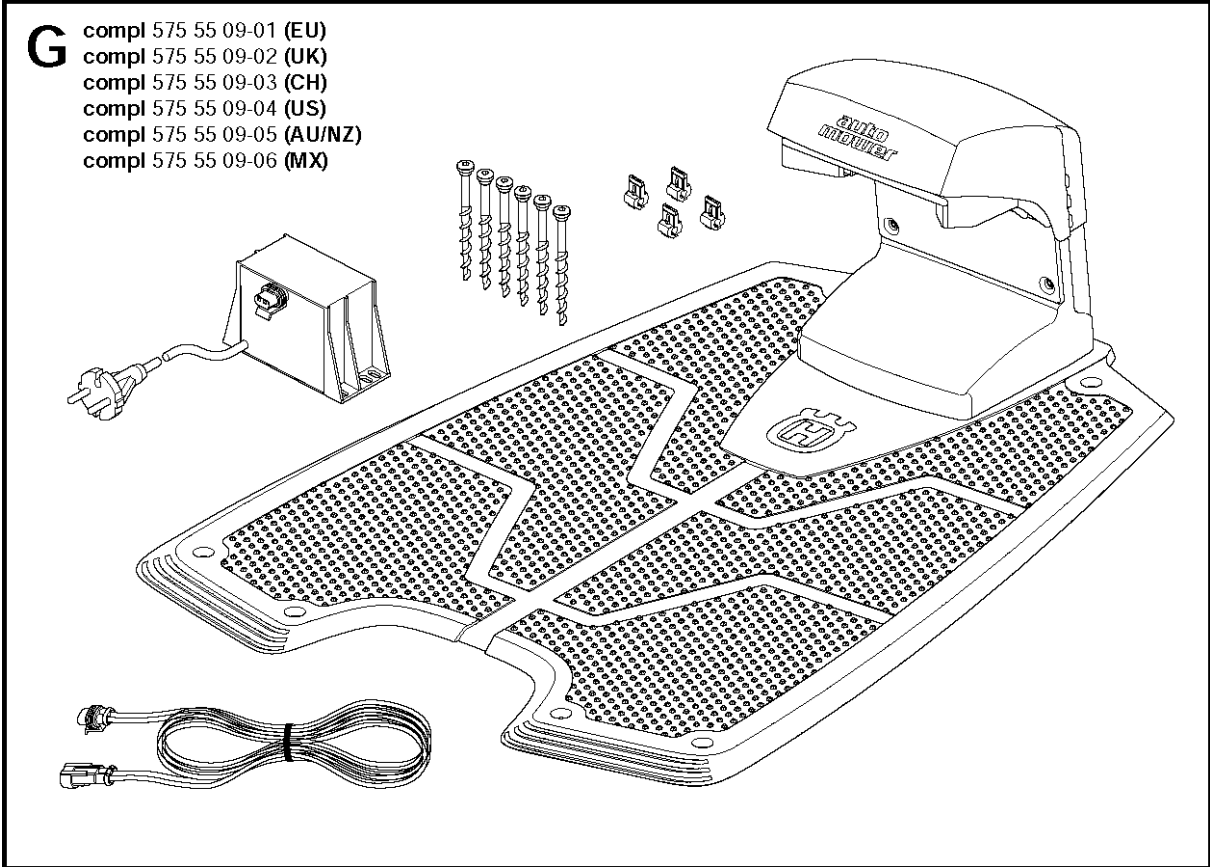

CHARGING STATION

SOLAR HYBRID , 2011-01

Part No	Description	Remark	QTY KIT
575 55 09-01	CHARGING STATION		1
575 55 09-02	CHARGING STATION		1
575 55 09-03	CHARGING STATION		1
575 55 09-04	CHARGING STATION		1
575 55 09-05	CHARGING STATION		1
575 55 09-06	CHARGING STATION		1

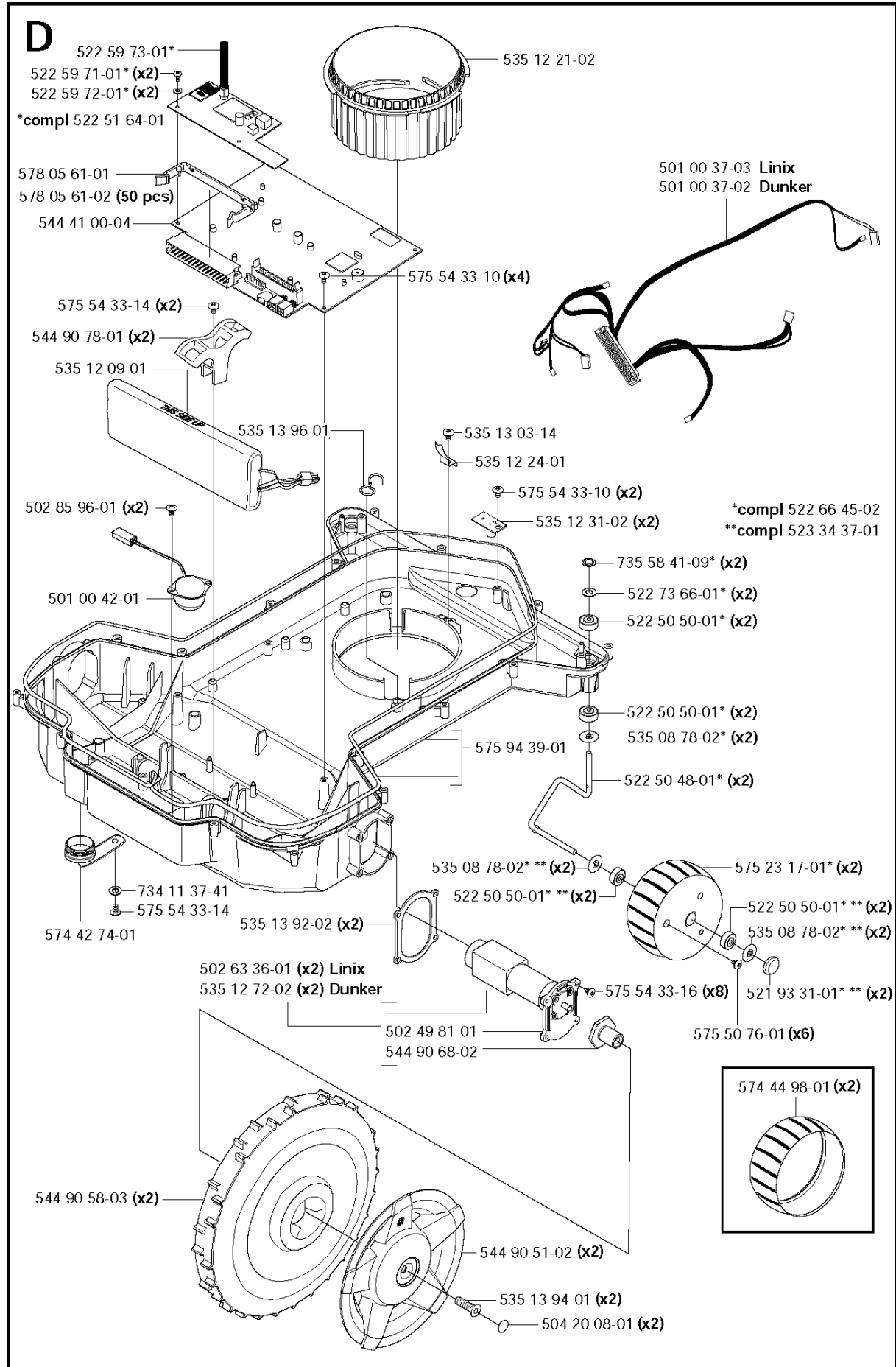

CHASSIS LOWER

SOLAR HYBRID , 2011-01

Part No	Description	Remark	QTY KIT
501 00 37-02	MAIN WIRING		1
501 00 37-03	MAIN WIRING		1
501 00 42-01	LOUD SPEAKER		1
502 49 81-01	GABLE		1
502 63 36-01	DRIVE MOTOR		2
502 85 96-01	SCREW		1
504 20 08-01	COVER WASHER		1
521 93 31-01	COVER WASHER		2
522 50 48-01	SPINDLE		2
522 50 50-01	BALL BEARING		2
522 50 50-01	BALL BEARING		2
522 50 50-01	BALL BEARING		2
522 50 50-01	BALL BEARING		2
522 51 64-01	GSM MODULE		1
522 59 71-01	SCREW		1
522 59 72-01	WASHER		1
522 59 73-01	ANTENNA		1
522 66 45-02	KIT		1
522 73 66-01	WASHER		2
523 34 37-01	BEARING KIT		1
535 08 78-02	WASHER		2
535 08 78-02	WASHER		2
535 08 78-02	WASHER		2
535 12 09-01	BATTERY		1
535 12 21-02	NUT		1
535 12 24-01	LOCKING SPRING		1
535 12 31-02	SENSOR CARD		1
535 12 72-02	PROJECTIVE LIST		2
535 13 03-14	SCREW ITXPANT		1
535 13 92-02	GASKET		1
535 13 94-01	SCREW IHCSFM		1
535 13 96-01	CABLE HOLDER		1
544 41 00-04	PRINTED CIRCUIT ASSY		1
544 90 51-02	HUB CAP		1
544 90 58-03	REAR WHEEL		1
544 90 68-02	HUB		1
544 90 78-01	BRACKET		1
574 42 74-01	PLUG		1
574 44 98-01	WHEEL		2
575 23 17-01	WHEEL ASSY		2
575 50 76-01	SCREW ITXPANT		6
575 54 33-10	SCREW		4
575 54 33-10	SCREW		1
575 54 33-14	SCREW		1
575 54 33-14	SCREW		1
575 54 33-16	SCREW		1
575 94 39-01	CHASSIS		1
578 05 61-01	CLIP		1
578 05 61-02	CLIP		1
734 11 37-41	WASHER		1
735 58 41-09	WASHER		2

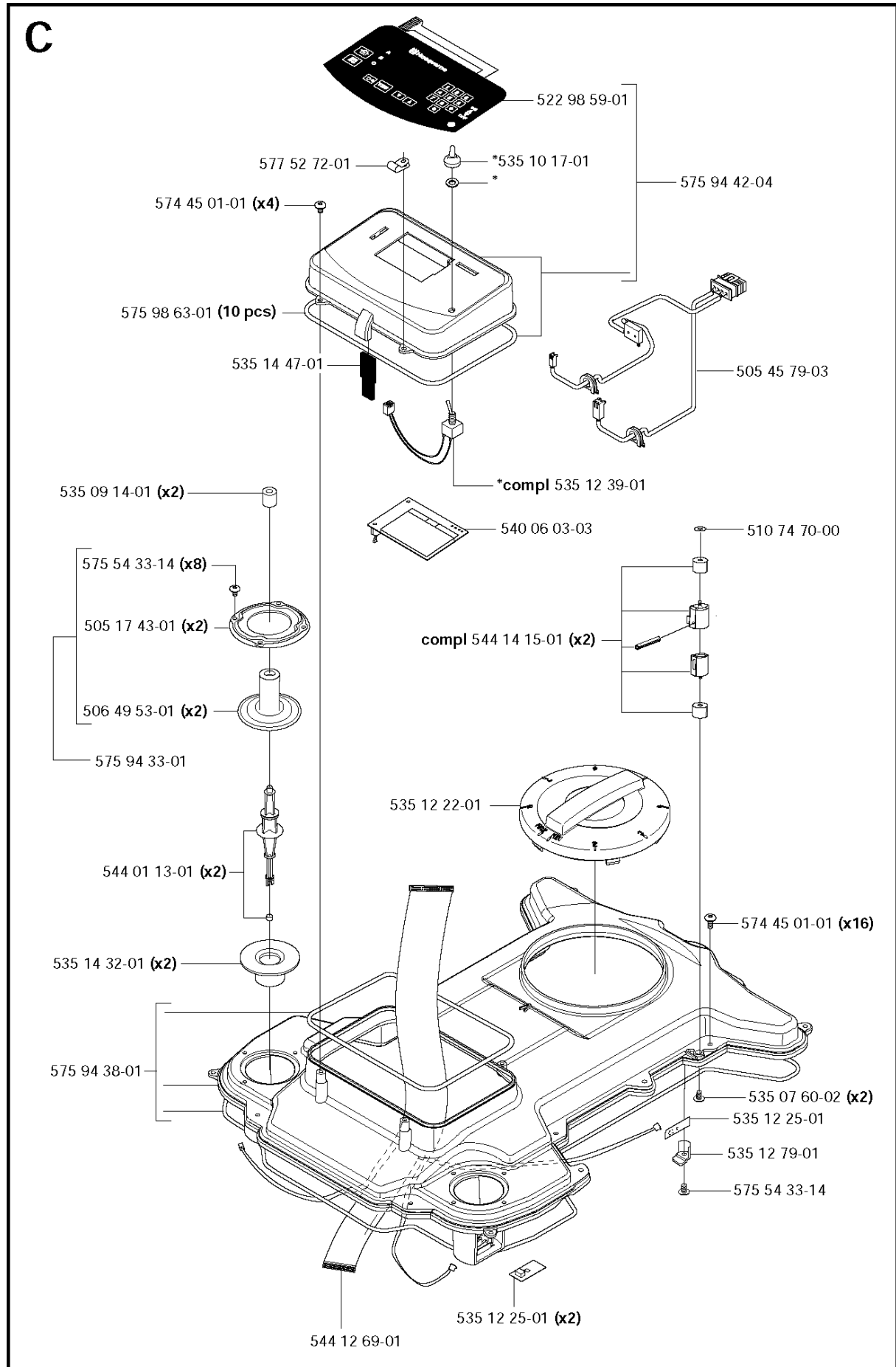

CHASSIS UPPER

SOLAR HYBRID , 2011-01

Ref	Part No	Description	Remark	QTY KIT
574 45 01-01	574 45 01-01	SCREW ITXPANT		1
535 07 60-02	535 07 60-02	SCREW		1
544 12 69-01	544 12 69-01	WIRING		1
535 12 22-01	535 12 22-01	STEERING WHEEL		1
535 12 25-01	535 12 25-01	SENSOR CARD		2
575 54 33-14	575 54 33-14	SCREW		1
535 12 79-01	535 12 79-01	BRACKET		1
535 12 25-01	535 12 25-01	SENSOR CARD		1
505 45 79-03	505 45 79-03	CABLE		1
574 45 01-01	574 45 01-01	SCREW ITXPANT		1
522 98 59-01	522 98 59-01	KEYBOARD		1
540 06 03-03	540 06 03-03	DISPLAY		1
535 10 17-01	535 10 17-01	HUB CAP		1
535 12 39-01	535 12 39-01	MAIN SWITCH		1
535 14 47-01	535 14 47-01	FILTER		1
544 14 15-01	544 14 15-01	SENSOR		2
575 94 38-01	575 94 38-01	CHASSIS		1
510 74 70-00	510 74 70-00	LOCKWASHER		1
575 98 63-01	575 98 63-02	SEALING STRIP		1
535 09 14-01	535 09 14-01	RUBBER DAMPER		2
575 54 33-14	575 54 33-14	SCREW		8
505 17 43-01	505 17 43-01	RING FASTENER		2
506 49 53-01	506 49 53-01	RUBBER GAITERS		2
575 94 33-01	575 94 33-01	KIT		1
575 94 42-04	575 94 42-04	DISPLAY COVER		1
544 01 13-01	544 01 13-01	COLUMN		2
535 14 32-01	535 14 32-01	DEFLECTION LIMITER		2
577 52 72-01	577 52 72-01	CABLE CLAMP		1

B

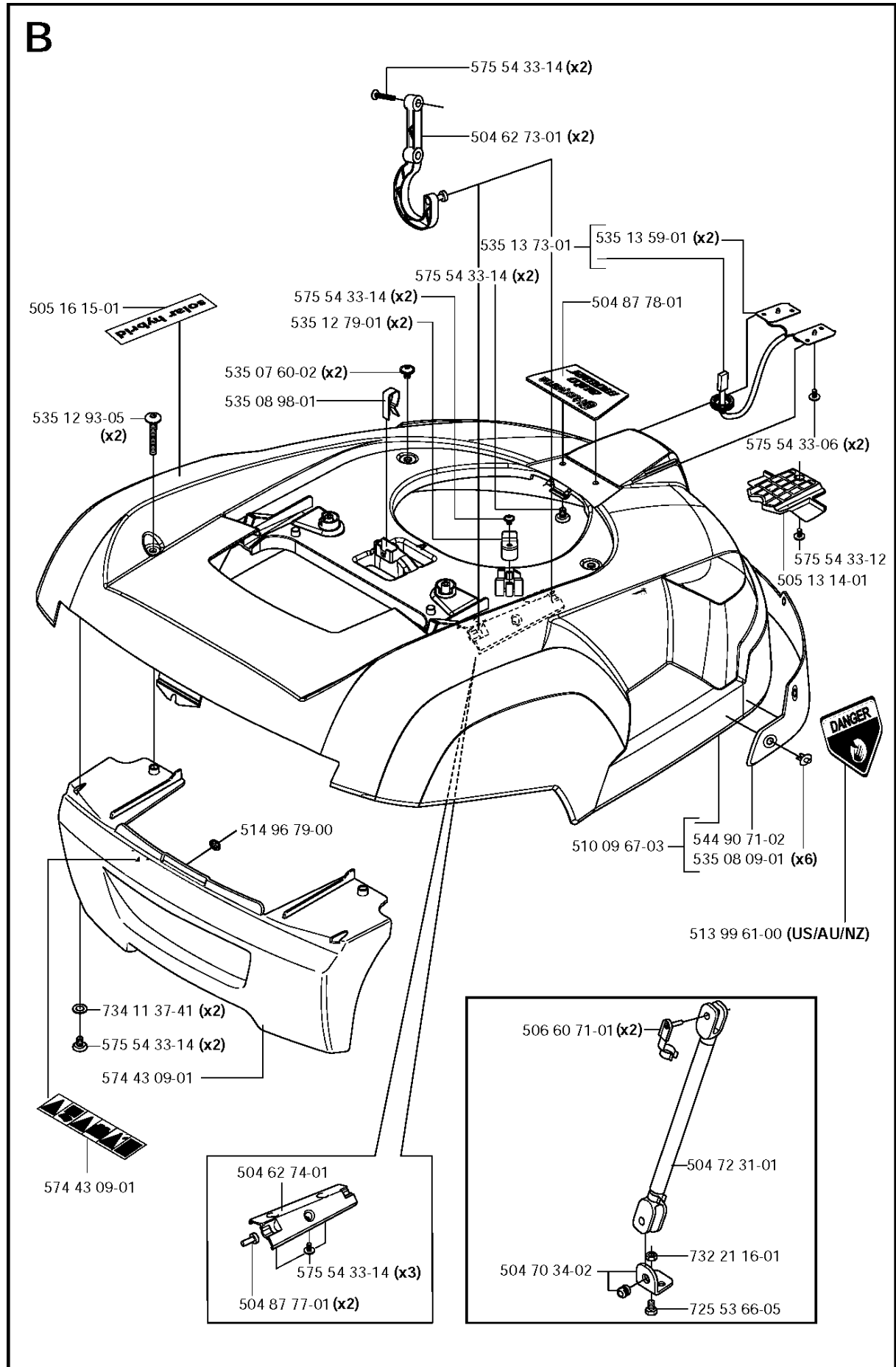

COVER

SOLAR HYBRID , 2011-01

Part No	Description	Remark	QTY KIT
504 62 73-01	HINGE		1
504 62 74-01	BRACKET		1
504 70 34-02	BRACKET		1
504 72 31-01	GAS STRUT		1
504 87 77-01	PIN		1
504 87 78-01	PLATE		1
505 13 14-01	SPACER		1
505 16 15-01	DECAL		1
506 60 71-01	SPRINT		2
510 09 67-03	BODY		1
513 99 61-00	DECAL		1
514 96 79-00	STARLOCK WASHER		1
535 07 60-02	SCREW		2
535 08 09-01	RIVET		6
535 08 98-01	CLIPS		1
535 12 79-01	BRACKET		1
535 12 93-05	SCREW IHANM		2
535 13 59-01	CHARGING PLATE		2
535 13 73-01	WIRING		1
544 90 71-02	BUMPER		1
574 43 09-01	BUMPER		1
574 43 09-01	BUMPER		1
575 54 33-06	SCREW		2
575 54 33-12	SCREW		1
575 54 33-14	SCREW		1
575 54 33-14	SCREW		4
575 54 33-14	SCREW		2
575 54 33-14	SCREW		3
725 53 66-05	SCREW IHSCM		1
732 21 16-01	NUT		1
734 11 37-41	WASHER		2

H

535 12 37-01 (EU)
 535 12 37-02 (UK/IRL)
 535 12 37-03 (CH)
 535 12 37-04 (US)
 535 12 37-05 (AU/NZ)
 535 12 37-06 (MX)

504 04 97-01 (100 pcs)

575 23 86-01 (6 pcs)

535 12 73-06 (20 m)

501 98 03-02 (150 m)

501 98 03-01 (250 m)

522 91 41-01 (500 m, Ø3.4 mm)

535 12 90-01

501 98 02-01 (1 pcs)

501 98 02-02 (50 pcs)

544 17 75-01

535 13 16-01

ANTI THEFT PROTECTED

INSTALLATION ACCESSORIES

SOLAR HYBRID , 2011-01

Part No	Description	Remark	QTY KIT
501 98 02-01	COUPLER		1
501 98 02-02	COUPLER		1
501 98 03-01	WIRE		1
501 98 03-02	WIRE		1
504 04 97-01	STAPLE		1
522 91 41-01	WIRE		1
535 12 37-01	TRANSFORMER		1
535 12 37-02	TRANSFORMER		1
535 12 37-03	TRANSFORMER		1
535 12 37-04	TRANSFORMER		1
535 12 37-05	TRANSFORMER		1
535 12 37-06	TRANSFORMER		1
535 12 73-06	CABLE		1
535 12 90-01	COUPLER		1
535 13 16-01	LABEL		1
544 17 75-01	MEASURING TAPE		1
575 23 86-01	SCREW KIT		1

A compl 504 62 68-01

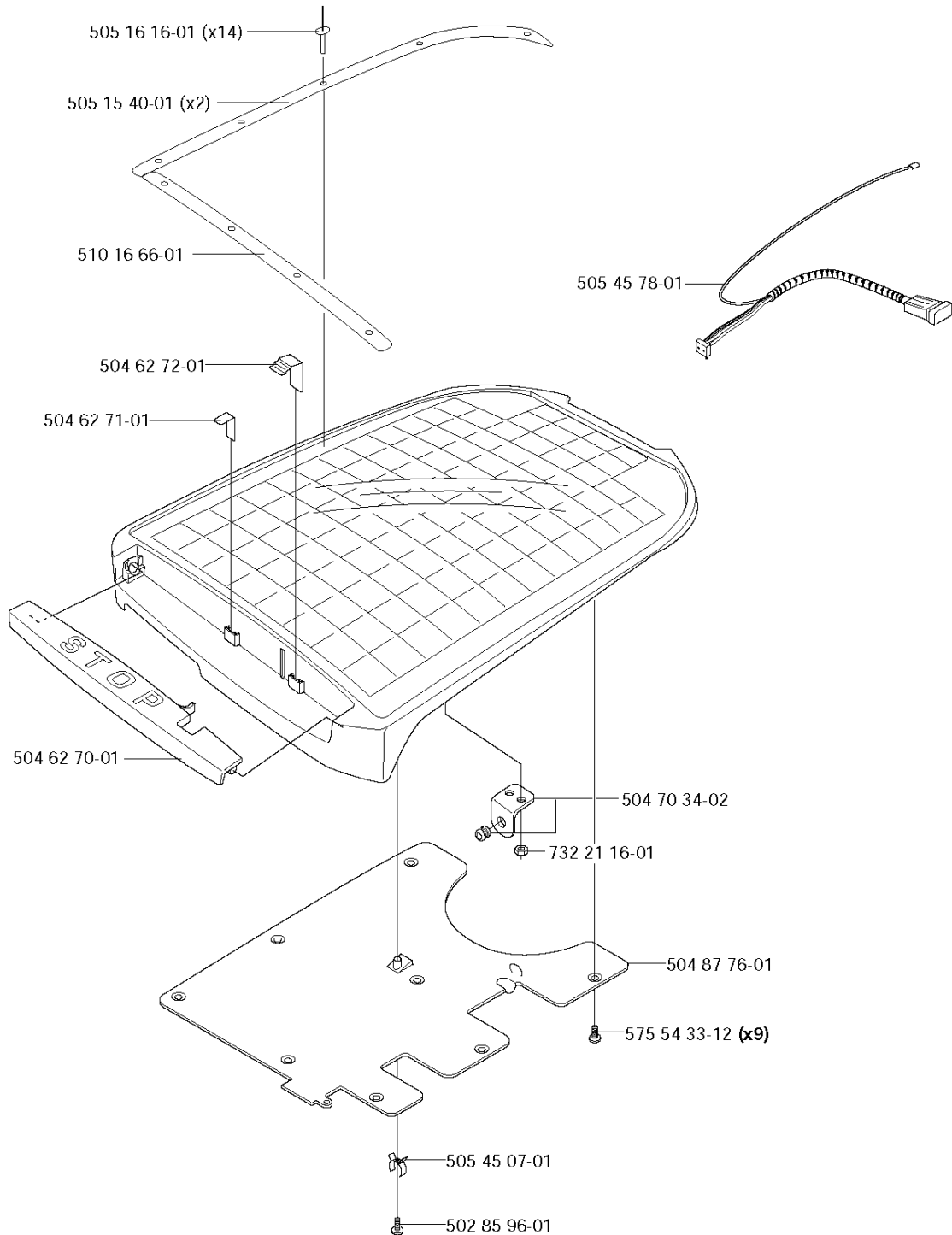

SOLAR GENERATOR

SOLAR HYBRID , 2011-01

Part No	Description	Remark	QTY KIT
502 85 96-01	SCREW		1
504 62 68-01	COVER		1
504 62 70-01	BUTTON		1
504 62 71-01	SPRING PLATE		1
504 62 72-01	LATCH		1
504 70 34-02	BRACKET		1
504 87 76-01	COVER LID		1
505 15 40-01	FRAME		2
505 16 16-01	RIVET		14
505 45 07-01	LATCH		1
505 45 78-01	CABLE		1
510 16 66-01	FRAME		1
575 54 33-12	SCREW		9
732 21 16-01	NUT		1